

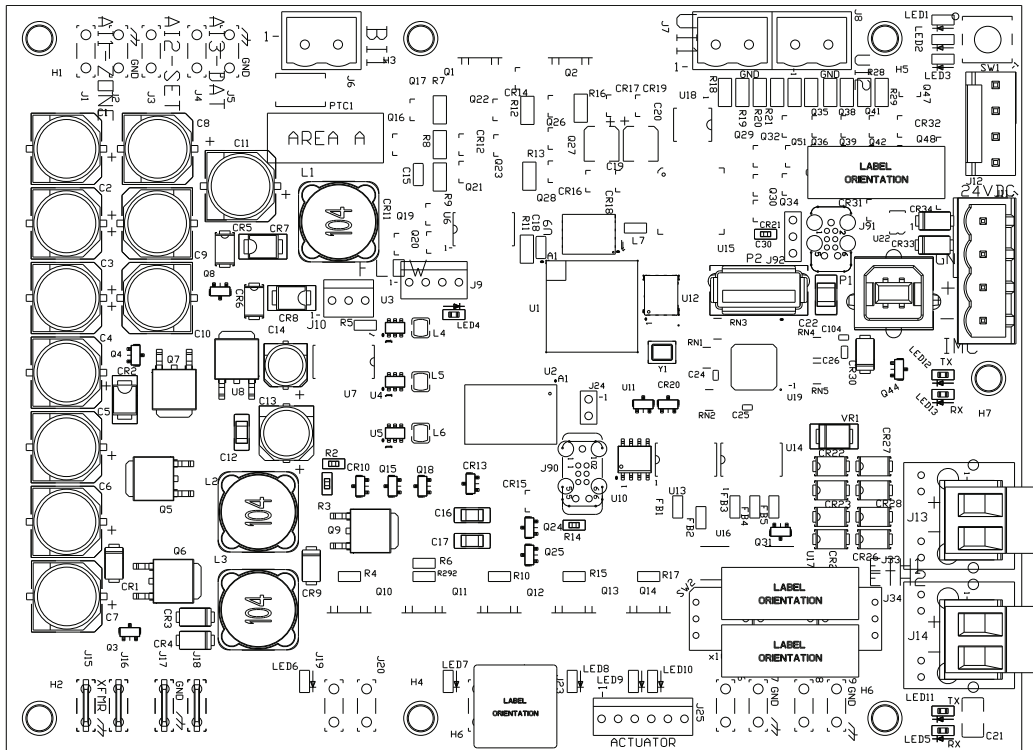

# Integration Guide

# BACnet® Communication Interface for ReliaTel™ Controllers (BCI2-R)



## ▲ SAFETY WARNING

Only qualified personnel should install and service the equipment. The installation, starting up, and servicing of heating, ventilating, and air-conditioning equipment can be hazardous and requires specific knowledge and training. Improperly installed, adjusted or altered equipment by an unqualified person could result in death or serious injury. When working on the equipment, observe all precautions in the literature and on the tags, stickers, and labels that are attached to the equipment.



# Introduction

The BACnet Communication Interface for ReliaTel (BCI2-R) supports Trane ReliaTel rooftop units that function as part of a BACnet MS/TP communications network. It allows ReliaTel equipment to communicate with a building automation system (BAS) by using the BACnet protocol over an RS-485 MS/TP communications link. For more detailed information about this protocol, visit [www.bacnetinternational.org](http://www.bacnetinternational.org) This guide provides the following information:

- Configuring the BCI2-R with the embedded BCI2 Service Tool and Tracer TU.
- Operating the BCI2-R as part of a building automation system.
- Interpreting the BCI2-R LEDs.
- Object data points and diagnostic data points.

## Warnings, Cautions, and Notices

Safety advisories appear throughout this manual as required. Your personal safety and the proper operation of this machine depend upon the strict observance of these precautions.

The three types of advisories are defined as follows:



**WARNING**

Indicates a potentially hazardous situation which, if not avoided, could result in death or serious injury.



**CAUTION**

Indicates a potentially hazardous situation which, if not avoided, could result in minor or moderate injury. It could also be used to alert against unsafe practices.

**NOTICE**

Indicates a situation that could result in equipment or property-damage only accidents.

### **⚠ WARNING**

#### **Proper Field Wiring and Grounding Required!**

**Failure to follow code could result in death or serious injury.**

**All field wiring MUST be performed by qualified personnel. Improperly installed and grounded field wiring poses FIRE and ELECTROCUTION hazards. To avoid these hazards, you MUST follow requirements for field wiring installation and grounding as described in NEC and your local/state/national electrical codes.**

**⚠ WARNING****Personal Protective Equipment (PPE) Required!**

Failure to wear proper PPE for the job being undertaken could result in death or serious injury.

Technicians, in order to protect themselves from potential electrical, mechanical, and chemical hazards, **MUST** follow precautions in this manual and on the tags, stickers, and labels, as well as the instructions below:

- Before installing/servicing this unit, technicians **MUST** put on all PPE required for the work being undertaken (Examples; cut resistant gloves/sleeves, butyl gloves, safety glasses, hard hat/bump cap, fall protection, electrical PPE and arc flash clothing). **ALWAYS** refer to appropriate Safety Data Sheets (SDS) and OSHA guidelines for proper PPE.
- When working with or around hazardous chemicals, **ALWAYS** refer to the appropriate SDS and OSHA/GHS (Global Harmonized System of Classification and Labelling of Chemicals) guidelines for information on allowable personal exposure levels, proper respiratory protection and handling instructions.
- If there is a risk of energized electrical contact, arc, or flash, technicians **MUST** put on all PPE in accordance with OSHA, NFPA 70E, or other country-specific requirements for arc flash protection, **PRIOR** to servicing the unit. **NEVER PERFORM ANY SWITCHING, DISCONNECTING, OR VOLTAGE TESTING WITHOUT PROPER ELECTRICAL PPE AND ARC FLASH CLOTHING. ENSURE ELECTRICAL METERS AND EQUIPMENT ARE PROPERLY RATED FOR INTENDED VOLTAGE.**

**⚠ WARNING****Follow EHS Policies!**

Failure to follow instructions below could result in death or serious injury.

- All Trane personnel must follow the company's Environmental, Health and Safety (EHS) policies when performing work such as hot work, electrical, fall protection, lockout/tagout, refrigerant handling, etc. Where local regulations are more stringent than these policies, those regulations supersede these policies.
- Non-Trane personnel should always follow local regulations.

## Copyright

This document and the information in it are the property of Trane, and may not be used or reproduced in whole or in part without written permission. Trane reserves the right to revise this publication at any time, and to make changes to its content without obligation to notify any person of such revision or change.

## Trademarks

All trademarks referenced in this document are the trademarks of their respective owners.



# Table of Contents

BACnet Protocol .....	6
BACnet Testing Laboratory (BTL) Certification.....	6
Getting Started .....	7
Required Software and Tools .....	7
What to Do First .....	7
Setting Rotary Dial Address using the Embedded BCI2 Software Tool .....	7
Selecting Wireless Communication.....	8
Configuring the BCI2-R .....	9
Using the BCI2 Service Tool .....	9
Using Tracer TU .....	10
Configuring the BCI2-R Controller .....	12
Rotary Dial Values and BACnet Device ID .....	13
Rotary Dial Values .....	13
BACnet Device ID .....	13
Rotary Dial Address Settings for Non-Trane Front-end Systems .....	14
What To do After Adding Options or Equipment to the Unit .....	15
Clearing the BCI2-R Controller .....	15
Using the Embedded BCI2 Service Tool to Clear The Controller .....	15
Using Tracer TU to Clear the Controller .....	15
Updating the Application Code.....	15
Managing Device Units on the Controller Units Screen.....	15
BCI2-R Operation .....	17
BAS Unit Control .....	17
Initiating System Control .....	17
Output and Input Object Data Points .....	17
Periodic Update of BAS Values .....	17
BAS Communication Failure .....	18
Input/Output Commands and Calculations .....	18
Filter Timer Reset Command .....	18
Diagnostics Reset Command.....	18
Setpoint Calculations .....	19
Timestamped Configuration .....	19
LEDs .....	20
BACnet Data Points and Configuration Property Definitions .....	21
BACnet Protocol Implementation Conformance Statement (PICS).....	21
Standardized Device Profile (Annex L) .....	21
Interoperability Building Blocks (Annex K).....	21
Segmentation Capability.....	22

Object Types.....	22
BACnet .....	34
Data Link layer Options.....	34
Device Address Binding .....	34
Networking Options.....	34
Character Sets.....	34
Object Data Points and Diagnostic Data Points.....	35
Additional Resources .....	61



## BACnet Protocol

The Building Automation and Control Network (BACnet®) protocol is ANSI/ASHRAE Standard 135. This standard allows building automation systems or components from different manufacturers to share information and control functions. BACnet® provides building owners the capability to connect various types of building control systems or subsystems together for many uses. Multiple vendors can use this protocol to share information for monitoring and supervisory control between systems and devices in a multi-vendor interconnected system. The BACnet® protocol defines standard objects (data points) called BACnet® objects. Each object has a defined list of properties that provide context information about that object. In addition, BACnet® defines a number of application services that are used to interact with objects in a BACnet® device.

## BACnet Testing Laboratory (BTL) Certification

The BCI2-R supports the BACnet communication protocol and has been designed to meet the requirements of the BACnet Building Controller (B-BC) control profile. For more details, refer to the BTL web site at [www.bacnetinternational.org](http://www.bacnetinternational.org).



# Getting Started

This section describes the necessary software, tools, and initial tasks that are required for a successful integration.

## Required Software and Tools

The following are required:

- Embedded BCI2 Service Tool **OR** Tracer TU Service Tool version 11.6 or higher.
- A USB-A to USB-B cable for use with both the embedded BCI2 Service Tool and Tracer TU.
- A 1/8 inch (3 mm) flathead screwdriver.

## What to Do First

It is best practice to perform the following tasks in the order in which they are listed:

- BCI2-R is the factory with a default address. This address is found on a label applied to the circuit board. If the factory address needs to be changed see the following section "[Setting Rotary Dial Address using the Embedded BCI2 Software Tool](#)," p. 7 on how this is changed.
- BCI2-R is from the factory set to BACnet MSTP. If the installation is for a BACnet MSTP network, then nothing needs to be changed. However, if Air-Fi wireless is the protocol, then the communications protocol needs to be changed. See "[Selecting Wireless Communication](#)," p. 8 section on how to perform using the embedded BCI2 Service Tool.
- Configure the BCI2-R by using either the embedded BCI2 Service Tool or Tracer TU. See "[Configuring the BCI2-R](#)," p. 9 section for more information.
  - The default baud rate is 76,800 bps.
  - The default software device ID is the rotary switch address.
  - The device units do not have defaults; the BCI2 Service Tool or Tracer TU will display the device units of the controller to which it is connected.

## Setting Rotary Dial Address using the Embedded BCI2 Software Tool

Previous versions of BCI2-R had rotary dials to set the controller address. The BCI2-R controller does not have rotary dials to set the address. A default address is set at the factory and recorded on a label applied to the circuit board. The address can be changed using the embedded BCI2 Service Tool.

Follow these instructions to change the address of the controller:

1. Use a USB-A to USB-B cable. Plug the USB-B end into the Service Port on the BCI2. Plug the USB-A end into a laptop.
2. Open a browser in the laptop.
3. Enter 198.80.18.1
4. The BCI2 Service Tool will be served up from the BCI2 controller.
5. Navigate to **Installation > Identification and Communication > Protocol Configuration > Edit**.
6. Set the Rotary Dial Setting (address) by clicking the line and typing in the new address.
7. If the Device ID needs to be changed check the box next to Use Software Device ID and enter the desired device ID.

**Important:** Each device on the BACnet MS/TP link must have a unique rotary switch value. Otherwise, communication problems will occur.

**Note:** All devices are TP requestors with valid rotary switch values of 001 to 127 for BACnet MSTP and 1 to 999 for BACnet Air-Fi.

**Figure 1. Setting the controller address with the embedded BC12 Service Tool**

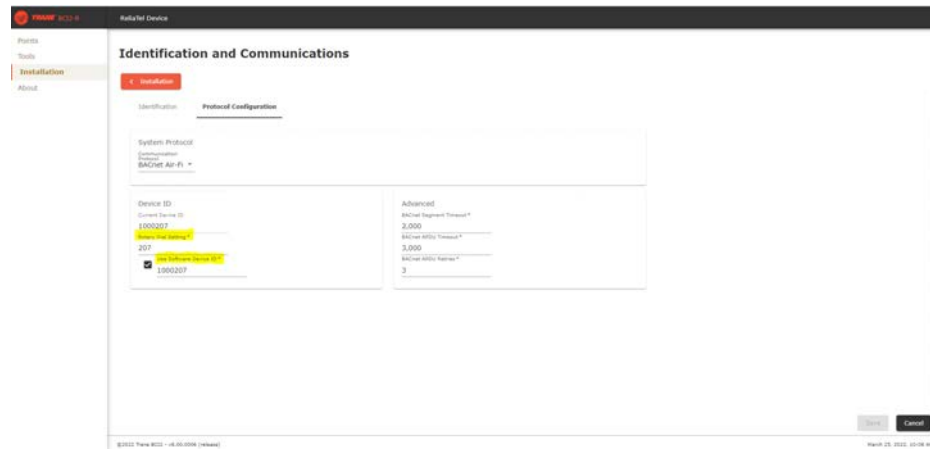

## Selecting Wireless Communication

If using an Air-Fi wireless COMM interface (WCI).

Set the communications protocol to Air-Fi Wireless by following these instructions:

1. Use a USB-A to USB-B cable. Plug the USB-B end into the Service Port on the BC12. Plug the USB-A end into a laptop.
2. Open a browser in the laptop.
3. Enter 198.80.18.1
4. The BC12 Service Tool will be served up from the BC12 controller.
5. Navigate to **Installation > Identification and Communication > Protocol Configuration > Edit**.
6. Set the System Protocol to BACnet Air-Fi.
7. Save.

For wiring instructions, refer to the following figure and "Air-Fi Wireless Communication Installation Instructions", BAS-SVN038\*-EN.

**Figure 2. Wiring the Air-Fi Wireless Communication Interface (WCI)**

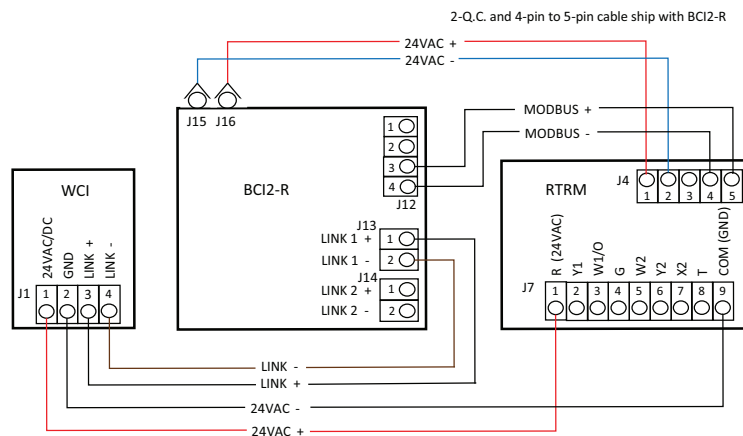



# Configuring the BCI2-R

The BCI2-R can be configured using either the embedded BCI2 Service Tool or the Tracer TU service.

## Using the BCI2 Service Tool

This section describes how to configure the BCI2 controller using the embedded BCI2 Service Tool.

1. Use a USB-A to USB-B cable. Plug the USB-B end into the Service Port on the BCI2. Plug the USB-A end into a laptop.
2. Open a browser in the laptop.
3. Enter 198.80.18.1
4. The BCI2 Service Tool will be served up from the BCI2 controller.
5. Navigate to **Installation > Identification and Communication > Protocol Configuration > Edit**.
6. Set the Communication Protocol with the drop down menu.
7. Set the Rotary Dial Setting (address) by clicking the line and typing in the new address.
8. If the Device ID needs to be changed check the box next to Use Software Device ID and enter the desired device ID.
9. To override or put points in/out of service, navigate to **Points > [point type]**. See [Figure 4, p. 10](#)[Figure 5, p. 10](#)[Figure 6, p. 10](#).

**Figure 3. Protocol Configuration**

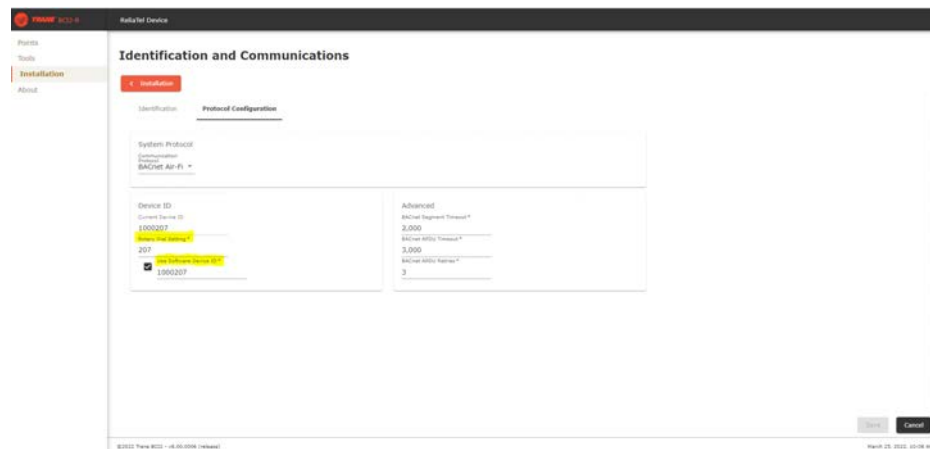

**Figure 4. Points list**

Instance	Name	Value	Alarm	Override	Service
1	Cooling Capacity Status	0.0 %			
2	Heat Primary Capacity Status	100.0 %	●		
4	Filter Runtime Hours	5,927.25	●		
7	Supply Fan Speed Command	100.0 %	●		
8	Exhaust Fan Speed Command	0.0 %	●		
11	Outdoor Air Damper Position Status	10.0 %	●		
15	Space Temperature Active	72.7 °F	●		

**Figure 5. Points Service screen**

Service Space Temperature Active

Change the point service to

In Service

Out Of Service

Set value to

72.7 °F

Cancel
Save

**Figure 6. Points Override screen**

Override Space Temperature BAS

Override Details

Release manual overrides

Control point value

Change value to:

65 °F

Present Value

The value is controlled to 65.0 °F by BCI2 Service Tool since March 24, 2022, 1:52 PM

Cancel
Save

## Using Tracer TU

This section describes how to first connect to the Tracer TU software and then configure the BCI2-R controller. If Tracer TU is not installed, refer to the Tracer TU Service Tool Getting Started Guide (TTU-SVN02\*-EN).

To connect to Tracer TU v 11.6 or higher:

1. Connect the USB cable directly from the laptop to the BCI2-R, or to an equipment control panel USB port connected to the controller.
2. Click either the **Tracer TU** desktop icon or the **Tracer TU** program item in the Tracer TU group on the **Start** menu. The Tracer TU splash screen appears briefly followed by the **Startup Task Panel** box.

**Figure 7. Tracer TU Startup Task Panel**

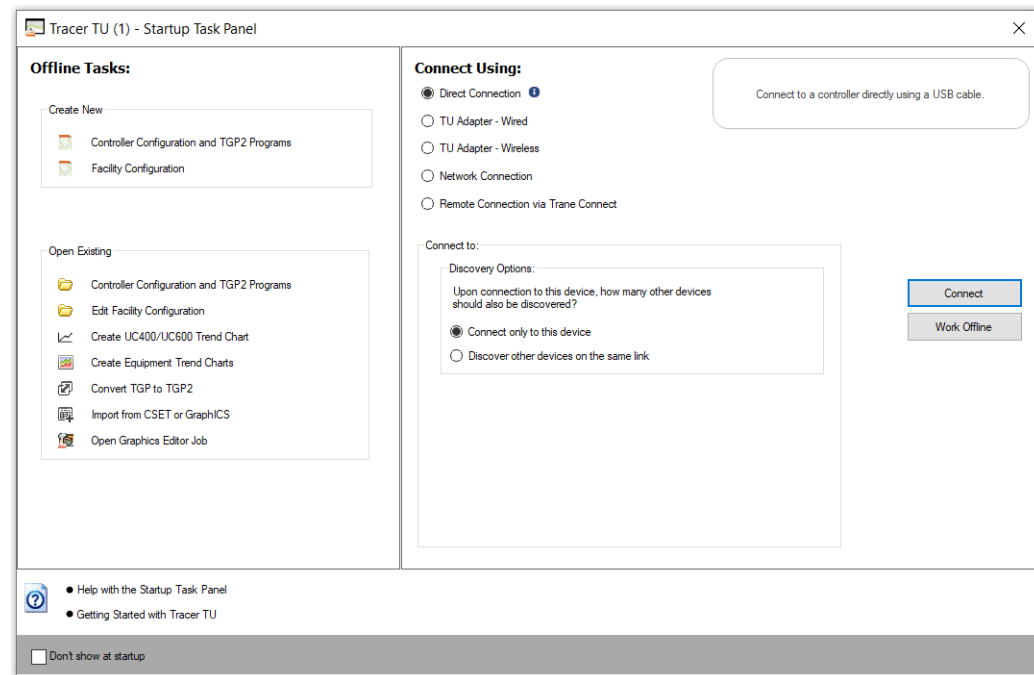

3. Select the **Direct Connection (USB cable)** radio button if it is not already selected.
4. Click the **Connect** button and the **Unit Summary** page will appear after successful connection.

**Figure 8. TU Unit Summary**

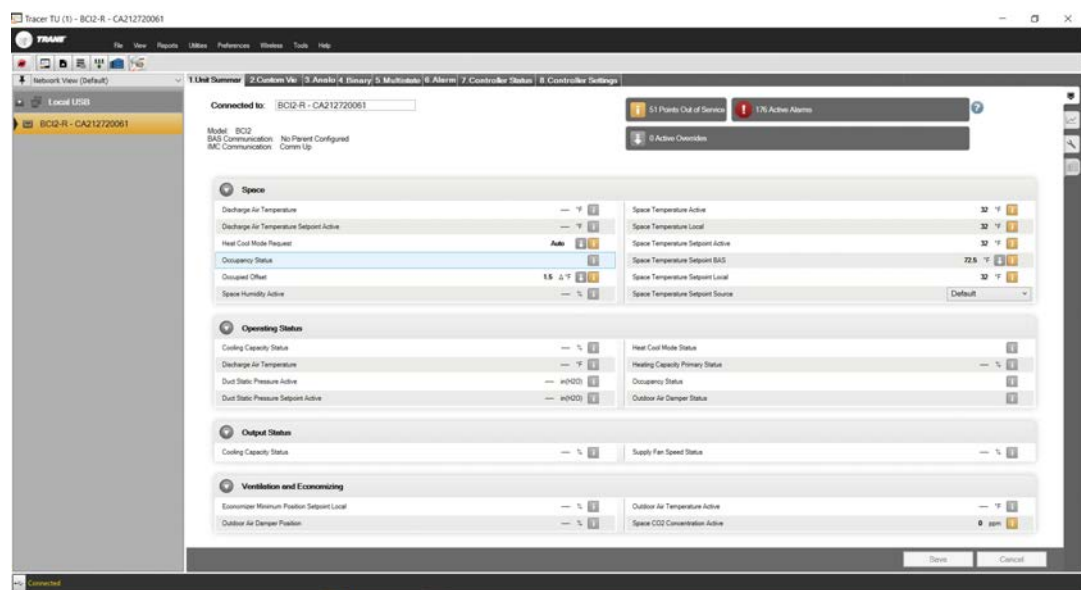

### Configuring the BCI2-R Controller

1. Select the **Controller Settings Utility** tab from the vertical tab set located on the right side of the TU window.

**Note:** The content of this screen is based on the type of controller that is connected and the system protocol used to communicate with the controller.

**Figure 9. TU Controller Settings tab**

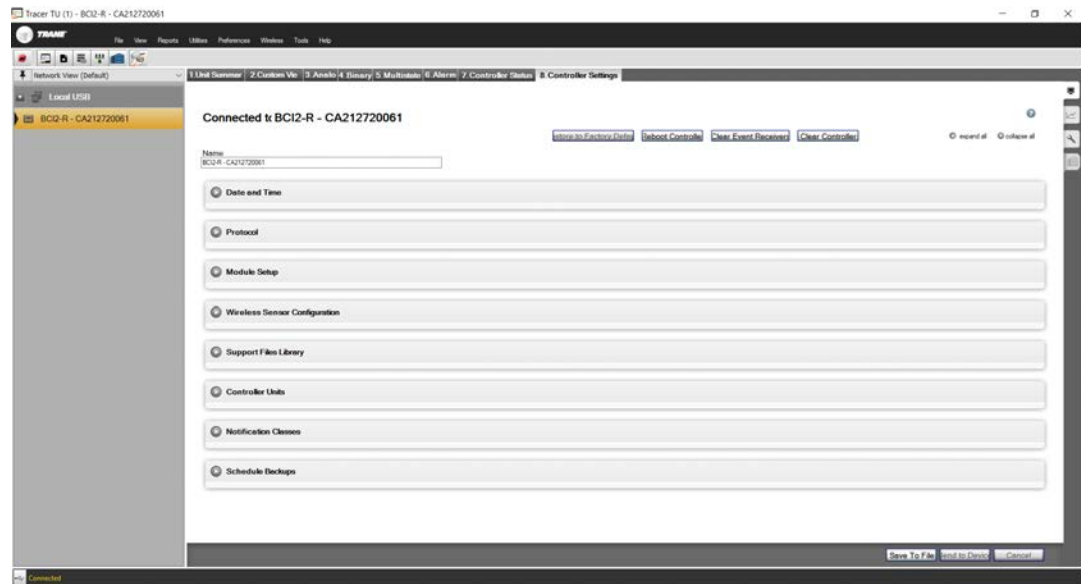

2. Enter a meaningful name for the controller.
3. Click the **Controller Units** expanding box label to display its contents.
4. Select the preferred units of measure for data communicated across the BACnet link.
5. Click the **Protocol** expanding box heading to display its contents.
6. Select the preferred **Baud Rate** in the drop-down list box.
7. If a software Device ID is required, check the **Use Software Device ID** box and enter a BACnet Device ID.
8. Click Save.



# Rotary Dial Values and BACnet Device ID

## Rotary Dial Values

**Note:** The Rotary Dial on a BCI2-R is no longer set by three rotary switches as it has been in the past. The rotary dial address is set by using the embedded BCI2 Software Tool. See "Setting Rotary Dial Address using the embedded BCI2 Software Tool" section on how to do this.

The rotary dial value is the physical address of a device on a network. It is often referred to as the MAC address. The term is generic and is used to denote the physical address of many types of networks.

For Trane systems, this address must be between 1 and 127 for BACnet MSTP networks and 1 to 999 for Air-Fi networks. Although "0,0,0," is a valid BACnet address, Trane reserves this address for the Tracer SC system controller. All controllers on the BACnet MSTP link must be set to a unique rotary dial address. The rotary dial address on BCI2-R is set using the embedded BCI2 Service Tool.

## BACnet Device ID

Tracer SC uses the rotary dial value to create the BACnet device ID. The Tracer SC adds an SC rotary dial address and a link number to artificially create a unique BACnet Device ID for each node.

The following figure shows how Tracer TU displays the rotary dial settings and the resulting BACnet device ID (similar is shown in BCI2 Service Tool):

- The rotary dial address on the BCI2-R are set to 30 (0,3,0).
- The Tracer SC created a BACnet device ID of 101030.
- The Tracer SC address is "0,1,0".
- The BCI2-R is installed on link 1.

**Figure 10. Rotary dial settings and BACnet device ID in Tracer TU**

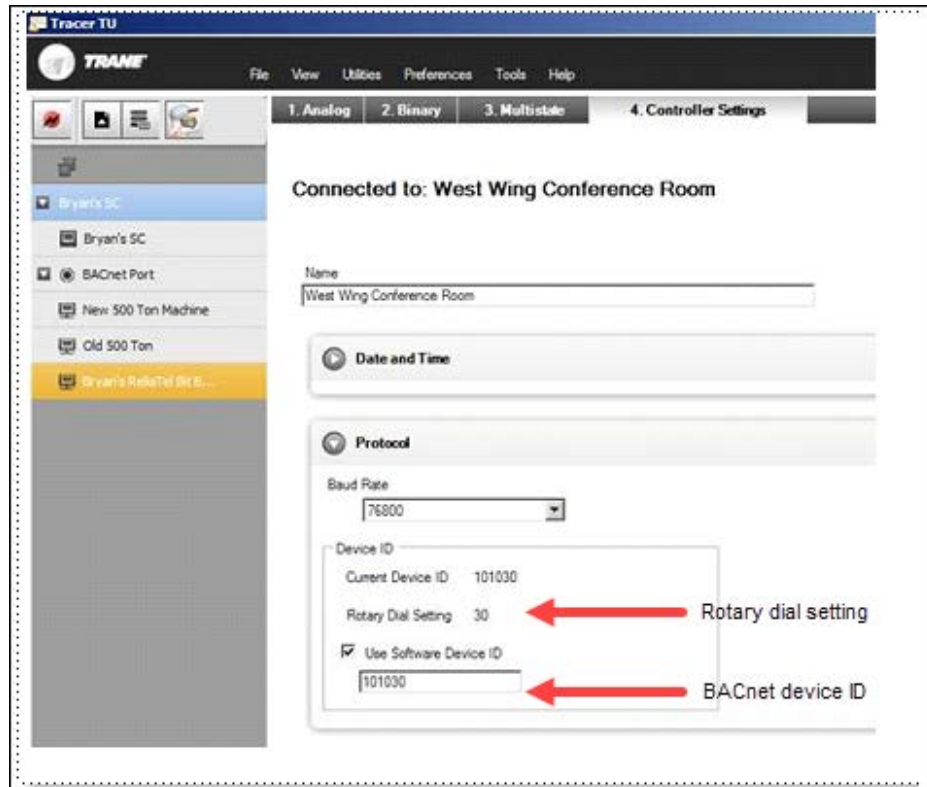



## Rotary Dial Address Settings for Non-Trane Front-end Systems

For non-Trane front-end systems, the Max Requestor value must be greater than the unique address settings from the rotary dials. Although 999 is possible from the dials, the maximum allowed number by BACnet is 127.

The Max Requestor is not adjustable in front-end systems. For example, if the rotary dial value is 101 and the front-end system has a Max Requestor value of 100, the device will not be discovered.

Many systems have a minimum BACnet device ID value. Ensure that the device ID is greater than this value.



# What To do After Adding Options or Equipment to the Unit

Clearing the BCI2-R controller is necessary if the unit setup has changed after the initial self-configuration process. This process is called “clearing the controller”.

For example, an economizer is added to the machine after the initial installation. In order for the BCI2-R controller to recognize the economizer, it must be cleared.

The BCI2-R controller self-configures upon initial power-up to match the connected equipment type. This configuration is then permanently stored in the memory of the controller. Through this process, the controller generates the correct list of BACnet points.

## Clearing the BCI2-R Controller

Clearing the controller is necessary to collect equipment information and reinstall the configuration.

### Using the Embedded BCI2 Service Tool to Clear The Controller

The following procedure clears the controller:

1. Use a USB-A to USB-B cable. Plug the USB-B end into the Service Port on the BCI2. Plug the USB-A end into a laptop.
2. Open a browser in the laptop.
3. Enter 198.80.18.1.
4. The BCI2 Service Tool will be served up from the BCI2 controller.
5. Navigate to **Tools > Backup and Restore > Clear Controller**
6. You will be prompted, if you would like to **Continue**.
7. The BCI2-R is cleared and ready to accept a new configuration.

### Using Tracer TU to Clear the Controller

1. Establish the connection between Tracer TU and the BCI2-R controller.
2. Select the Controller Settings Utility tab from the vertical tab set located on the right side of the TU window.
3. On the controller settings page there is a **Clear Controller** button in the upper right portion of the screen display.
4. Click the **Clear Controller** button and a pop-up window will appear with a message that asks for confirmation to reset the device. Click **Yes**.
5. A pop-up window will appear confirming that the controller has been reset and that the controller will be restarted. Click **OK**.
6. Follow the steps in Configuring the BCI2-R to reconfigure the controller.

## Updating the Application Code

The application code in the BCI2-R controller can be upgraded in the field by using Tracer TU. Follow the instructions in Tracer TU to upgrade the application code.

## Managing Device Units on the Controller Units Screen

The BCI2-R device units can be viewed and managed on the Controller Units screen from Tracer TU or from System Units in the BCI2 Service Tool.

When the BCI2-R first powers up, or after the controller has been cleared, a list of points (the role document) is created from the information supplied to the BCI2-R from the ReliaTel RTRM module through the Modbus link.

**Note:** The BCI2-R creates the role document immediately (often within one second).



## What To do After Adding Options or Equipment to the Unit

---

Immediately after the points are created, the device units are set and saved and appear on the Controller Units screen. The values that correspond to the device units are set to default to SI values.

If you are using either the embedded BCI2 Service Tool or Tracer TU to change the Device Units to IP by clearing the controller, it is best to either unplug the Modbus cable to the BCI2-R, or to power down the entire unit (the BCI2-R). By doing this, the BCI2-R will not see Modbus traffic. This method will enable the Device Units radio button selection, which allows you to make changes.



## BCI2-R Operation

The control system on HVAC equipment has the ability to operate the unit as a stand-alone system or as part of a building automation system (BAS). The BCI2-R (either factory or field installed), by default, is configured for stand-alone operation. This configuration enables the HVAC equipment to operate prior to the commissioning of the unit into the BAS.

## BAS Unit Control

The BCI2-R operates by using setpoints and placing points in and out of service. This method consists of BACnet objects that the BAS can access to control and monitor the status of equipment. Place points in and out of service using BCI2 Service Tool or Tracer TU.

### Initiating System Control

To initiate system control:

1. Name binary output 1 (BO 1), *system control command*, active.  
Trane also recommends setting the *relinquish default value* to active when performing step 1.

**Note:** *BO 1 must be in service in order to control from a BAS.*

*you must make BO 1 active in order to receive commands from the BAS system control. If inactive, only monitoring and status are allowed. The object name for BO 1 is System Control Command.*

2. Place in service the output points that are required by your application.

**Note:** *The output points to be placed in service are dependent on the job, the unit configuration, and customer preference. The following list is an example of common output points that might be placed in service for constant volume (CV) units.*

- Multi-State Output 7, Occupancy Request
- Multi-State Output 8, Heat Cool Mode Request BAS
- Multi-State Output 2, Emergency Override Command
- Analog Output 2, Space Temperature Setpoint BAS
- Analog Output 29, Occupied Offset
- Analog Output 30, Standby Offset
- Analog Output 31, Unoccupied Cooling Setpoint
- Analog Output 32, Unoccupied Heating Setpoint
- Analog Output 9, Space Static Pressure Setpoint BAS

### Output and Input Object Data Points

- Output objects are used by the BAS to provide command, setpoint, and sensor information to the rooftop unit. By default, most output objects are placed out of service to allow standalone unit operation before commissioning.
- Input objects provide ReliaTel status information to the BAS. See for a list of supported objects. By default, all input objects are placed in service to allow monitoring of unit operation, even in standalone mode, before commissioning.

You can define the amount of control that the BAS system will apply to the unit. This is done by configuring the state of the *Out of Service* property of the output objects. If the property is set to *True*, the equipment will use a corresponding local value for control. If the property is set to *False*, the local value is ignored and the BAS-supplied value is used for control. The BAS value is provided to the rooftop unit by writing to the present value property of the corresponding output object. The factory default value for the *Out of Service* property of these objects is *True*.

### Periodic Update of BAS Values

The BCI2-R device requires the BAS system to periodically update the sensor values to protect against a loss of communication between the BAS and the BCI2-R. By BACnet definition, the present value of the object maintains the last value written to it, regardless of the amount of time

that has elapsed since the last write. If communication is lost for several minutes or longer, the present value of BAS-supplied sensor objects may no longer represent the current state of environmental conditions. This may result in decreased occupant comfort and damage to building systems.

### **BAS Communication Failure**

The BCI2-R is designed to minimize communication failure mode. It does this by monitoring the length of time that has elapsed since the last write to the present value of the sensor object. If the length of time exceeds a predefined limit, the BCI2-R places the object into the fault state and reverts to a unit-supplied sensor value for control. At power-up, the sensor objects are set to a fault state and remain in this state until a write is detected. Wireless sensors continue sensing

The following list is a set of sensor values that can be supplied by the BAS:

- Space Static Pressure BAS
- Space Air Temperature BAS
- Discharge Air Temperature BAS
- Duct Static Air Pressure BAS
- Outdoor Air Temperature BAS
- Outdoor Air Humidity BAS
- Outdoor Airflow BAS
- Space CO<sub>2</sub> Concentration BAS
- Space Humidity BAS

## **Input/Output Commands and Calculations**

This section provides the following information about certain inputs and outputs that perform unique control commands and calculations:

- Filter timer and diagnostic reset commands
- Setpoint calculations

### **Filter Timer Reset Command**

The BCI2-R uses the Filter Runtime Hours object (AI 6) to generate a diagnostic when its present value is greater than the Filter Runtime Hours Setpoint, (AV 1) present value. The procedure for resetting the timer is as follows:

The BAS changes the state of the Filter Timer Reset Command object (BO 13) to the active state. When the change to active state takes place, the BCI2-R sets the present value of the Filter Runtime Hours object to zero and then sets the Reset Command object back to the inactive state.

### **Diagnostics Reset Command**

The ReliaTel control system monitors the operation of the HVAC equipment. If an abnormal condition is detected, an event notification message is sent to the Tracer SC. a diagnostic message displays on the human interface of the equipment control panel. In addition, the set of internal diagnostics is mapped to the set of BACnet binary input objects. The corresponding BI object changes the state from inactive to active when the diagnostic is detected. The object has been configured to send a BACnet event message to external BACnet devices as defined by the protocol.

The BAS has the ability to reset internal diagnostics by controlling the state of the Diagnostic Reset Command object (BO 14). The procedure for resetting diagnostics is as follows:

- The BAS changes the state of the Diagnostic Reset to the active state. When the change to active state take place, the ReliaTel control system resets all internal diagnostics and sets the state of all of the diagnostic objects to inactive.
- Upon completion of this action, the BCI2-R sets the present value of the Diagnostic Reset Command object back to the inactive state.

The BAS has the ability to reset internal diagnostics by controlling the state of the *Diagnostic Reset Command* object (BO 14). The procedure for resetting diagnostics is as follows:

- The BAS changes the state of the *Diagnostic Reset* to the active state. When the change to *active* state take place, the ReliaTel control system resets all internal diagnostics and sets the state of all of the diagnostic objects to inactive.
- Upon completion of this action, the BCI2-R sets the present value of the *Diagnostic Reset Command* object back to the *inactive* state.

## Setpoint Calculations

The equipment has the ability to perform two (2) basic control functions:

- **Space air temperature control:** When the unit is configured for space air temperature control, it controls the air temperature of the space that contains the space air temperature sensor or the wireless space sensor. This value can be provided by wiring the sensor to the unit or by means of a sensor value provided by the BAS.
- **Discharge air temperature control:** When the unit is configured for discharge air control, it controls the temperature of the air leaving the unit to the discharge air temperature setpoint.

The illustration below shows how the various temperature setpoints are calculated for space temperature control. The active space temperature setpoint is calculated based on the space temperature setpoint and the two setpoint offset values when the unit is in an occupied mode. In unoccupied mode, the unoccupied heating and cooling setpoints are used as the active setpoint.

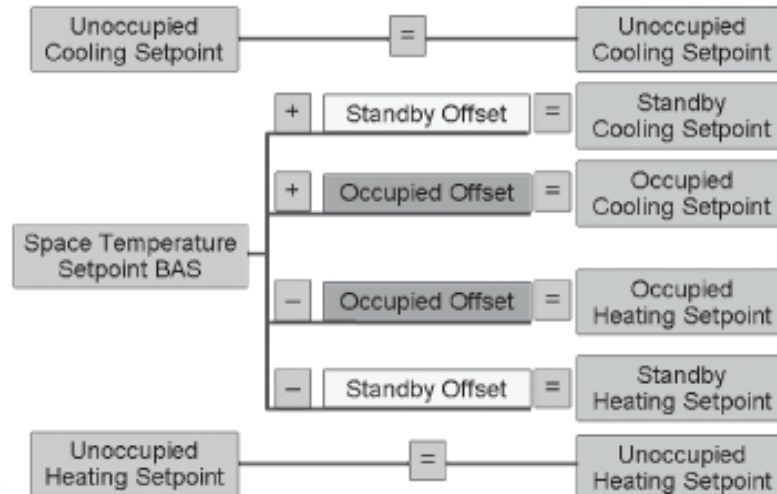

## Timestamped Configuration

The BCI2-R device has a software-derived clock that maintains the time and date. The device requires the current time in order to record timestamps when an event or a change in state is detected by a BACnet object. However, in the event of a power loss, the device does not maintain the time/date information. At power-up, the device time and date defaults to 12:00 p.m., Jan 1, 1970. To minimize the possibility that the unit time stamp is not representing the actual time, the BAS should be setup to periodically synchronize the device time clock with the BAS clock using the *BACnet TimeSynchronization service*.



# LEDs

**Table 1. Interpreting the LEDs and switches**

LED type	LED activity	Indicates...
Status LED 4 (green)	Solid on	Normal operation
	Steady blink pattern, 50% on and 50% off, repeating	BCI2 not connected to equipment (ReliaTel, IntelliPak, or CH530)
	Short/long flash pattern, repeating	Alarms or point faults are present
	Not illuminated	The controller is off
	2 blinks followed by a pause, repeating	The controller is booting.
	3 blinks followed by a pause, repeating	Controller firmware is updating.
	4 blinks followed by a pause, repeating	Data storage error, replace controller
	5 blinks followed by a pause, repeating	System error, restart controller or clear controller.
Link Tx	Tx flickering/blinking green	Normally illuminated; will be illuminated even if no data transferred or not connected to the link
	Not illuminated	No data transferring or not connected
Link Rx	Rx flickering/blinking yellow	Data is being transferred
	Not illuminated	No data is transferring or not connected
IMC Tx	Tx flickering/blinking green	Data is being transferred
	Not illuminated	No data is transferring or not connected
IMC Rx	Rx flickering/blinking yellow	Data is being transferred
	Not illuminated	No data is transferring or not connected



# BACnet Data Points and Configuration Property Definitions

The BCI2-R device allows an ReliaTel control system to communicate with BACnet systems and devices using BACnet MS/TP. This section includes information about:

- BACnet protocol implementation conformance statement (PICS).
- Object types: descriptions and configuration.
- BACnet protocol: data link layers, device address binding, networking options, and character sets.
- Object data points and configurations.

## BACnet Protocol Implementation Conformance Statement (PICS)

### Standardized Device Profile (Annex L)

Profile Description	Supported Profile
BACnet Operator Workstation (B-OWS)	<input type="checkbox"/>
BACnet Building Controller (B-BC)	<input checked="" type="checkbox"/>
BACnet Advanced Application Controller (B-AAC)	<input type="checkbox"/>
BACnet Application Specific Controller (B-ASC)	<input type="checkbox"/>
BACnet Smart Sensor (B-SS)	<input type="checkbox"/>
BACnet Smart Actuator (B-SA)	<input type="checkbox"/>
BACnet Router (B-RTR)	<input type="checkbox"/>
BACnet Broadcast Management Device (B-BBMD)	<input type="checkbox"/>

### Interoperability Building Blocks (Annex K)

Data Sharing Description	Supported
Data Sharing-ReadProperty-A (DS-RP-A)Data Sharing-Read Property-A (DS-RP-A)	<input checked="" type="checkbox"/>
Data Sharing-Read Property-B (DS-RP-B)	<input checked="" type="checkbox"/>
Data Sharing-Read Property Multiple-A (DS-RPM-A)	<input checked="" type="checkbox"/>
Data Sharing-Read Property Multiple-B (DS-RPM-B)	<input checked="" type="checkbox"/>
Data Sharing-Write Property-A (DS-WP-A)	<input checked="" type="checkbox"/>
Data Sharing-Write Property-B (DS-WP-B)	<input checked="" type="checkbox"/>
Data Sharing-Write Property Multiple-A (DS-WPM-A)	<input checked="" type="checkbox"/>
Data Sharing-Write Property Multiple-B (DS-WPM-B)	<input checked="" type="checkbox"/>
Data Sharing-Change Of Value-A (DS-COV-A)	<input checked="" type="checkbox"/>
Data Sharing-Change Of Value-B (DS-COV-B)	<input checked="" type="checkbox"/>
Alarm and Event Management Description	Supported
Alarm and Event-Notification-A (AE-N-A)	<input checked="" type="checkbox"/>
Alarm and Event-Notification-Internal-B (AE-N-I-B)	<input checked="" type="checkbox"/>
Alarm and Event-Acknowledge Alarm-A (AE-ACK-A) <input type="checkbox"/>	<input checked="" type="checkbox"/>
Alarm and Event-Acknowledge Alarm-B (AE-ACK-B)	<input checked="" type="checkbox"/>



## BACnet Data Points and Configuration Property Definitions

Data Sharing Description	Supported
Alarm and Event-Alarm Summary-B (AE-ASUM-B)	<input checked="" type="checkbox"/>
Alarm and Event-Enrollment Summary-B (AE-ESUM-B)	<input checked="" type="checkbox"/>
Alarm and Event-Information-B (AE-INFO-B)	<input checked="" type="checkbox"/>
Alarm and Event-Event Log-Internal-B (AE-EL-I-B)	<input checked="" type="checkbox"/>
Scheduling	Supported
Scheduling-Internal-B (SCHED-I-B)	<input checked="" type="checkbox"/>
Scheduling-External-B (SCHED-E-B)	<input checked="" type="checkbox"/>
Trending	Supported
Trending-Viewing and Modifying Trends-Internal-B (T-VMT-I-B)	<input checked="" type="checkbox"/>
Trending-Viewing and Modifying Trends-External-B (T-VMT-E-B)	<input checked="" type="checkbox"/>
Trending-Automated Trend Retrieval-B (T-ATR-B)	<input checked="" type="checkbox"/>
Device Management Description	Supported
Device Management-Dynamic Device Binding-A (DM-DDB-A)	<input checked="" type="checkbox"/>
Device Management-Dynamic Device Binding-B (DM-DDB-B)	<input checked="" type="checkbox"/>
Device Management-Dynamic Object Binding-B (DM-DOB-B)	<input checked="" type="checkbox"/>
Device Management-Device Communication Control-B (DM-DCC-B)	<input checked="" type="checkbox"/>
Device Management-Time Synchronization-B (DM-TS-B)	<input checked="" type="checkbox"/>
Device Management-UTC-Time Synchronization-B (DM-UTC-B)	<input checked="" type="checkbox"/>
Device Management-Reinitialize Device-B (DM-RD-B)	<input checked="" type="checkbox"/>
Device Management-Backup and Restore-B (DM-BR-B)	<input checked="" type="checkbox"/>
Device Management-List Manipulation-B (DM-LM-B)	<input checked="" type="checkbox"/>
Device Management-Object Creation and Deletion-B (DM-OCD-B)	<input checked="" type="checkbox"/>

### Segmentation Capability

Segmentation Description	Supported Segment
Segmented Requests/ Window Size: 1	<input checked="" type="checkbox"/>
Segmented Responses/ Window Size: 1	<input checked="" type="checkbox"/>

### Object Types

The table below lists the properties that are supported for each object type in this control device. The BACnet standard specifies many properties as optional, unless the device supports a particular BACnet feature. If the feature is supported then the optional properties are required. In the table, the properties that are defined as optional but required to support a specific functionality, have been placed in the Required Properties column.

## BACnet Data Points and Configuration Property Definitions

**Table 2. Descriptions and configurations**

Object Type	Required Properties	Properties Properties	Writable Properties (a)	Ability to Create	Ability to Delete
Analog Input	<ul style="list-style-type: none"> <li>• Object_Identifier</li> <li>• Object_Name</li> <li>• Object_Type</li> <li>• Present_Value</li> <li>• Status_Flags</li> <li>• Event_State</li> <li>• Out_Of_Service</li> <li>• Units</li> <li>• COV_Increment</li> <li>• Time_Delay</li> <li>• Notificatin Class</li> <li>• High_Limit</li> <li>• Low_Limit</li> <li>• Deadband</li> <li>• Limit_Enable</li> <li>• Event_Enable</li> <li>• Acked_Transitions</li> <li>• Notify_Type</li> <li>• Event_Time_Stamps</li> <li>• Event_Detection_Enable</li> <li>• Event_Algorithm_Inhibit_Ref</li> <li>• Event_Algorithm_Inhibit</li> <li>• Property List</li> </ul>	<ul style="list-style-type: none"> <li>• Description</li> <li>• Reliability</li> <li>• Min_Pres_Value</li> <li>• Max_Pres_Value</li> </ul>	<ul style="list-style-type: none"> <li>• Object_Name</li> <li>• Present_Value</li> <li>• Description</li> <li>• Reliability</li> <li>• Out_of_Service</li> <li>• Min_Pres_Value</li> <li>• Max_Pres_Value</li> <li>• COV_Increment</li> <li>• Time_Delay</li> <li>• Notification_Class</li> <li>• High_Limit</li> <li>• Low_Limit</li> <li>• Deadband</li> <li>• Limit_Enable</li> <li>• Event_Enable</li> <li>• Notify_Type</li> <li>• Event_Detection_Enable</li> <li>• Event_Algorithm_Inhibit_Ref</li> <li>• Event_Algorithm_Inhibit</li> </ul>	No	No



## BACnet Data Points and Configuration Property Definitions

Table 2. Descriptions and configurations (continued)

Object Type	Required Properties	Properties Properties	Writable Properties (a)	Ability to Create	Ability to Delete
Analog Output	<ul style="list-style-type: none"> <li>• Object_Identifier</li> <li>• Object_Name</li> <li>• Object_Type</li> <li>• Present_Value</li> <li>• Status_Flags</li> <li>• Event_State</li> <li>• Out_Of_Service</li> <li>• Units</li> <li>• Priority_Array</li> <li>• Relinquish_Default</li> <li>• COV_Increment</li> <li>• Time_Delay</li> <li>• Notificatin Class</li> <li>• High_Limit</li> <li>• Low_Limit</li> <li>• Deadband</li> <li>• Limit_Enable</li> <li>• Event_Enable</li> <li>• Acked_Transitions</li> <li>• Notify_Type</li> <li>• Event_Time_Stamps</li> <li>• Event_Detection_Enable</li> <li>• Event_Algorithm_Inhibit_Ref</li> <li>• Event_Algorithm</li> <li>• Property List</li> </ul>	<ul style="list-style-type: none"> <li>• Description</li> <li>• Reliability</li> <li>• Min_Pres_Value</li> <li>• Max_Pres_Value</li> </ul>	<ul style="list-style-type: none"> <li>• Object_Name</li> <li>• Present_Value</li> <li>• Description</li> <li>• Reliability</li> <li>• Out_of_Service</li> <li>• Min_Pres_Value</li> <li>• Max_Pres_Value</li> <li>• Relinquish_Default</li> <li>• COV_Increment</li> <li>• Time_Delay</li> <li>• Notification_Class</li> <li>• High_Limit</li> <li>• Low_Limit</li> <li>• Deadband</li> <li>• Limit_Enable</li> <li>• Event_Enable</li> <li>• Notify_Type</li> <li>• Event_Detection_Enable</li> <li>• Event_Algorithm_Inhibit_Ref</li> <li>• Event_Algorithm_Inhibit</li> </ul>	No	No

## BACnet Data Points and Configuration Property Definitions

**Table 2. Descriptions and configurations (continued)**

Object Type	Required Properties	Properties Properties	Writable Properties (a)	Ability to Create	Ability to Delete
Analog Value	<ul style="list-style-type: none"> <li>• Object_Identifier</li> <li>• Object_Name</li> <li>• Object_Type</li> <li>• Present_Value</li> <li>• Status_Flags</li> <li>• Event_State</li> <li>• Out_Of_Service</li> <li>• Units</li> <li>• Priority_Array</li> <li>• Relinquish_Default</li> <li>• COV_Increment</li> <li>• Time_Delay</li> <li>• Notificatin Class</li> <li>• High_Limit</li> <li>• Low_Limit</li> <li>• Deadband</li> <li>• Limit_Enable</li> <li>• Event_Enable</li> <li>• Acked_Transitions</li> <li>• Notify_Type</li> <li>• Event_Time_Stamps</li> <li>• Event_Detection_Enable</li> <li>• Event_Algorithm_Inhibit_Ref</li> <li>• Event_Algorithm</li> <li>• Property List</li> </ul>	<ul style="list-style-type: none"> <li>• Description</li> <li>• Reliability</li> <li>• Min_Pres_Value</li> <li>• Max_Pres_Value</li> </ul>	<ul style="list-style-type: none"> <li>• Object_Name</li> <li>• Present_Value</li> <li>• Description</li> <li>• Reliability</li> <li>• Out_of_Service</li> <li>• Min_Pres_Value</li> <li>• Max_Pres_Value</li> <li>• Relinquish_Default</li> <li>• COV_Increment</li> <li>• Time_Delay</li> <li>• Notification_Class</li> <li>• High_Limit</li> <li>• Low_Limit</li> <li>• Deadband</li> <li>• Limit_Enable</li> <li>• Event_Enable</li> <li>• Notify_Type</li> <li>• Event_Detection_Enable</li> <li>• Event_Algorithm_Inhibit_Ref</li> <li>• Event_Algorithm_Inhibit</li> </ul>	No	No



## BACnet Data Points and Configuration Property Definitions

Table 2. Descriptions and configurations (continued)

Object Type	Required Properties	Properties Properties	Writable Properties (a)	Ability to Create	Ability to Delete
Binary Input	<ul style="list-style-type: none"> <li>• Object_Identifier</li> <li>• Object_Name</li> <li>• Object_Type</li> <li>• Present_Value</li> <li>• Status_Flags</li> <li>• Event_State</li> <li>• Out_Of_Service</li> <li>• Polarity</li> <li>• Active_Text</li> <li>• Inactive_Text</li> <li>• Change_Of_State_Time</li> <li>• Change_Of_State_Count</li> <li>• Time_of_State_Count_Reset</li> <li>• Elapsed_Active_Time</li> <li>• Time_of_Active_Time_Reset</li> <li>• Time_Delay</li> <li>• Notificatin Class</li> <li>• Alarm_Value</li> <li>• Event_Enable</li> <li>• Acked_Transitions</li> <li>• Notify_Type</li> <li>• Event_Time_Stamps</li> <li>• Event_Detection_Enable</li> <li>• Event_Algorithm_Ref</li> <li>• Event_Algorithm_Inhibit</li> </ul>	<ul style="list-style-type: none"> <li>• Description</li> <li>• Reliability</li> </ul>	<ul style="list-style-type: none"> <li>• Object_Name</li> <li>• Present_Value</li> <li>• Description</li> <li>• Reliability</li> <li>• Out_of_Service</li> <li>• Polarity</li> <li>• Inactive_Text</li> <li>• Active_Text</li> <li>• Change_of_State_Count</li> <li>• Elapsed_Active_Time</li> <li>• Time_Delay</li> <li>• Notification_Class</li> <li>• Alarm_Value</li> <li>• Event_Enable</li> <li>• Notify_Type</li> <li>• Event_Detection_Enable</li> <li>• Event_Algorithm_Inhibit_Ref</li> <li>• Event_Algorithm_Inhibit</li> </ul>	No	No

## BACnet Data Points and Configuration Property Definitions

**Table 2. Descriptions and configurations (continued)**

Object Type	Required Properties	Properties Properties	Writable Properties (a)	Ability to Create	Ability to Delete
Binary Output	<ul style="list-style-type: none"> <li>• Object_Identifier</li> <li>• Object_Name</li> <li>• Object_Type</li> <li>• Present_Value</li> <li>• Status_Flags</li> <li>• Event_State</li> <li>• Out_Of_Service</li> <li>• Polarity</li> <li>• Active_Text</li> <li>• Inactive_Text</li> <li>• Change_Of_State_Time</li> <li>• Change_Of_State_Count</li> <li>• Time_Of_State_Count_Reset</li> <li>• Elapsed_Active_Time</li> <li>• Time_of_Active_Time_Reset</li> <li>• Minimum_Off_Time</li> <li>• Minimum_On_Time</li> <li>• Priority_Array</li> <li>• Relinquish_Default</li> <li>• Time_Delay</li> <li>• Notificatin Class</li> <li>• Feedback_Value</li> <li>• Event_Enable</li> <li>• Acked_Transitions</li> <li>• Notify_Type</li> <li>• Event_Time_Stamps</li> <li>• Event_Detection_Enable</li> <li>• Event_Algorithm_Inhibit_Ref</li> <li>• Event_Algorithm</li> <li>• Property List</li> </ul>	<ul style="list-style-type: none"> <li>• Description</li> <li>• Reliability</li> </ul>	<ul style="list-style-type: none"> <li>• Object_Name</li> <li>• Present_Value</li> <li>• Description</li> <li>• Reliability</li> <li>• Out_of_Service</li> <li>• Polarity</li> <li>• Inactive_Text</li> <li>• Active_Text</li> <li>• Change_of_State_Count</li> <li>• Elapsed_Active_Time</li> <li>• Minimum_Off_Time</li> <li>• Minimum_On_Time</li> <li>• Relinquish_Default</li> <li>• Time_Delay</li> <li>• Notification_Class</li> <li>• Event_Enable</li> <li>• Notify_Type</li> <li>• Event_Detection_Enable</li> <li>• Event_Algorithm_Inhibit_Ref</li> <li>• Event_Algorithm_Inhibit</li> </ul>	No	No



## BACnet Data Points and Configuration Property Definitions

Table 2. Descriptions and configurations (continued)

Object Type	Required Properties	Properties Properties	Writable Properties (a)	Ability to Create	Ability to Delete
Binary Value	<ul style="list-style-type: none"> <li>• Object_Identifier</li> <li>• Object_Name</li> <li>• Object_Type</li> <li>• Present_Value</li> <li>• Status_Flags</li> <li>• Event_State</li> <li>• Out_Of_Service</li> <li>• Active_Text</li> <li>• Inactive_Text</li> <li>• Change_Of_State_Time</li> <li>• Change_Of_State_Count</li> <li>• Time_Of_State_Count_Reset</li> <li>• Elapsed_Active_Time</li> <li>• Time_of_Active_Time_Reset</li> <li>• Minimum_Off_Time</li> <li>• Minimum_On_Time</li> <li>• Priority_Array</li> <li>• Relinquish_Default</li> <li>• Time_Delay</li> <li>• Notificatin Class</li> <li>• Alarm_Value</li> <li>• Event_Enable</li> <li>• Acked_Transitions</li> <li>• Notify_Type</li> <li>• Event_Time_Stamps</li> <li>• Event_Detection_Enable</li> <li>• Event_Algorithm_Inhibit_Ref</li> <li>• Event_Algorithm</li> <li>• Property List</li> </ul>	<ul style="list-style-type: none"> <li>• Description</li> <li>• Reliability</li> </ul>	<ul style="list-style-type: none"> <li>• Object_Name</li> <li>• Present_Value</li> <li>• Description</li> <li>• Reliability</li> <li>• Out_of_Service</li> <li>• Inactive_Text</li> <li>• Active_Text</li> <li>• Change_of_State_Count</li> <li>• Elapsed_Active_Time</li> <li>• Minimum_Off_Time</li> <li>• Minimum_On_Time</li> <li>• Relinquish_Default</li> <li>• Time_Delay</li> <li>• Notification_Class</li> <li>• Alarm_Value</li> <li>• Event_Enable</li> <li>• Notify_Type</li> <li>• Event_Detection_Enable</li> <li>• Event_Algorithm_Inhibit_Ref</li> <li>• Event_Algorithm_Inhibit</li> </ul>	No	No
Calendar	<ul style="list-style-type: none"> <li>• Object_Identifier</li> <li>• Object_Name</li> <li>• Object_Type</li> <li>• Present_Value</li> <li>• Date_List</li> <li>• Property_List</li> </ul>	<ul style="list-style-type: none"> <li>• Description</li> </ul>	<ul style="list-style-type: none"> <li>• Object_Name</li> <li>• Description</li> <li>• Date_List</li> </ul>	No	No

## BACnet Data Points and Configuration Property Definitions

**Table 2. Descriptions and configurations (continued)**

Object Type	Required Properties	Properties Properties	Writable Properties (a)	Ability to Create	Ability to Delete
Device	<ul style="list-style-type: none"> <li>• Object_Identifier</li> <li>• Object_Name</li> <li>• Object_Type</li> <li>• System_Status</li> <li>• Vendor_Name</li> <li>• Vendor_Identifier</li> <li>• Model_Name</li> <li>• Firmware_Revision</li> <li>• Application_Software_Version</li> <li>• Protocol_Version</li> <li>• Protocol_Revision</li> <li>• Protocol_Services_Supported</li> <li>• Protocol_Object_Types_Supported</li> <li>• Object_List</li> <li>• Max_APDU_Length_Accepted</li> <li>• Segmentation_Supported</li> <li>• Max_Segments_Accepted</li> <li>• Local_Time</li> <li>• Local_Date</li> <li>• UTC-Offset</li> <li>• Daylight_Savings_Status</li> <li>• APDU_Segment_Timeout</li> <li>• APDU_Timeout</li> <li>• Number_Of_APDU_Retries</li> <li>• Max_Manager</li> <li>• Max_Info_Frames</li> <li>• Device_Address_Binding</li> <li>• Database_Revision</li> <li>• Configuration_Files</li> <li>• Last_Restore_Time</li> <li>• Backup_Failure_Timeout</li> <li>• Backup_Preparation_Time</li> <li>• Restore_Preperation_Time</li> <li>• Restore_Completion_Time</li> <li>• Backup_and_Restore_State</li> <li>• Acitve_COV_Subscriptions</li> <li>• Time_of_Device_Restart</li> <li>• Serial_Number</li> <li>• Property_List</li> <li>• Property_Name</li> </ul>	<ul style="list-style-type: none"> <li>• Location</li> <li>• Description</li> </ul>	<ul style="list-style-type: none"> <li>• Object_Name</li> <li>• Location</li> <li>• Description</li> <li>• UTC_Offset</li> <li>• Backup_Failure_Timeout</li> <li>• APDU_Segment_timeout</li> <li>• APDU_Timeout</li> <li>• Number_Of_APDU_Retries</li> </ul>	No	No



## BACnet Data Points and Configuration Property Definitions

**Table 2. Descriptions and configurations (continued)**

Object Type	Required Properties	Properties Properties	Writable Properties (a)	Ability to Create	Ability to Delete
Event Enrollment Object	<ul style="list-style-type: none"> <li>• Object_Identifier</li> <li>• Object_Name</li> <li>• Object_Type</li> <li>• Event_Type</li> <li>• Notify_Type</li> <li>• Event_Parameters</li> <li>• Object_Property_Reference</li> <li>• Event_State</li> <li>• Event_Enable</li> <li>• Acked_Transitions</li> <li>• Notification_Class</li> <li>• Event_Time_Stamps</li> <li>• Event_Detection_Enable</li> <li>• Event_Algorithm_Inhibit</li> <li>• Event_Algorithm_Inhibit</li> <li>• Status_Flags</li> <li>• Reliability</li> <li>• Property_List</li> </ul>	<ul style="list-style-type: none"> <li>• Description</li> </ul>	<ul style="list-style-type: none"> <li>• Object_Name</li> <li>• Description</li> <li>• Event_Parameters</li> <li>• Object_Property_Reference</li> <li>• Event_Enable</li> <li>• Notification_Clase</li> <li>• Event_Detection_Enable</li> <li>• Event_Algorithm_Inhibit_Ref</li> <li>• Event_Algoithm_Inhibit</li> <li>• Reliability</li> <li>• Notify_Type</li> </ul>	No	No
Event Log Object	<ul style="list-style-type: none"> <li>• Object_Identifier</li> <li>• Object_Name</li> <li>• Object_Type</li> <li>• Present_Value</li> <li>• Status_Flags</li> <li>• Event_State</li> <li>• Enable</li> <li>• Stop_When_Full</li> <li>• Buffer Size</li> <li>• Log_Buffer</li> <li>• Record_Count</li> <li>• Total_Record_Count</li> </ul>	None	<ul style="list-style-type: none"> <li>• Object_Name</li> <li>• Description</li> <li>• Record_Count</li> </ul>	No	No
File	<ul style="list-style-type: none"> <li>• Object_Identifier</li> <li>• Object_Name</li> <li>• Object_Type</li> <li>• Fle_Type</li> <li>• File_Size</li> <li>• Modification_Date</li> <li>• Archive</li> <li>• Read_Only</li> <li>• File_Access_M d</li> <li>• Property_List</li> </ul>	None	<ul style="list-style-type: none"> <li>• File_Size (0 Only)</li> <li>• Archive</li> </ul>	No	No

## BACnet Data Points and Configuration Property Definitions

**Table 2. Descriptions and configurations (continued)**

Object Type	Required Properties	Properties Properties	Writable Properties (a)	Ability to Create	Ability to Delete
Multistate Input	<ul style="list-style-type: none"> <li>• Object_Identifier</li> <li>• Object_Name</li> <li>• Object_Type</li> <li>• Present_Value</li> <li>• Status_Flags</li> <li>• Event_State</li> <li>• Out_Of_Service</li> <li>• Number_Of_States</li> <li>• Time_Delay</li> <li>• Notification_Class</li> <li>• Alarm_Values</li> <li>• Event_Enable</li> <li>• Acked_Transitions</li> <li>• Notify_Type</li> <li>• Event_Time_Stamps</li> <li>• Event_Detection_Enable</li> <li>• Event_Algorithm_Inhibit_Ref</li> <li>• Event_Algorithm</li> <li>• Property_List</li> </ul>	<ul style="list-style-type: none"> <li>• Description</li> <li>• Reliability</li> <li>• State_Text</li> <li>• Fault_Value</li> </ul>	<ul style="list-style-type: none"> <li>• Object_Name</li> <li>• Present_Value</li> <li>• State_Text</li> <li>• Reliability</li> <li>• Time_Delay</li> <li>• Notification_Class</li> <li>• Alarm_Values</li> <li>• Fault_Values</li> <li>• Event_Enable</li> <li>• Acked_Transitions</li> <li>• Notify_Type</li> <li>• Event_Time_Stamps</li> <li>• Event_Detection_Enable</li> <li>• Event_Algorithm_Inhibit_Ref</li> <li>• Event_Algorithm_Inhibit</li> </ul>	No	No
Multistate Output	<ul style="list-style-type: none"> <li>• Object_Type</li> <li>• Present_Value</li> <li>• Status_Flags</li> <li>• Event_State</li> <li>• Out_Of_Service</li> <li>• Number_Of_States</li> <li>• Priority_Array</li> <li>• Relinquish_Default</li> <li>• Time_Delay</li> <li>• Notification_Class</li> <li>• Feedback_Value</li> <li>• Event_Enable</li> <li>• Acked_Transitions</li> <li>• Notify_Type</li> <li>• Event_Time_Stamps</li> <li>• Event_Detection_Enable</li> <li>• Event_Algorithm_Inhibit_Ref</li> <li>• Event_Algoith</li> <li>• Property_List</li> </ul>	<ul style="list-style-type: none"> <li>• Description</li> <li>• Reliability</li> <li>• State_Text</li> </ul>	<ul style="list-style-type: none"> <li>• Object_Name</li> <li>• Present_Value</li> <li>• Description</li> <li>• Reliability</li> <li>• Out_of_Service</li> <li>• Number_of_States</li> <li>• Relinquish_Default</li> <li>• State_Text</li> <li>• Time_Delay</li> <li>• Notification_Class</li> <li>• Event_Enable</li> <li>• Notify_Type</li> <li>• Event_Detection_Enable</li> <li>• Event_Algorithm_Inhibit f</li> <li>• Event_Algorithm_Inhibit</li> <li>• Description</li> </ul>	No	No

## BACnet Data Points and Configuration Property Definitions

**Table 2. Descriptions and configurations (continued)**

<b>Object Type</b>	<b>Required Properties</b>	<b>Properties Properties</b>	<b>Writable Properties (a)</b>	<b>Ability to Create</b>	<b>Ability to Delete</b>
Multistate Value	<ul style="list-style-type: none"> <li>• Object_Identifier</li> <li>• Object_Name</li> <li>• Object_Type</li> <li>• Present_Value</li> <li>• Status_Flags</li> <li>• Event_State</li> <li>• Out_Of_Service</li> <li>• Number_Of_States</li> <li>• Priority_Array</li> <li>• Relinquish_Default</li> <li>• Time_Delay</li> <li>• Notification_Class</li> <li>• Alarm_Values</li> <li>• Fault_Values</li> <li>• Event_Enable</li> <li>• Acked_Transitions</li> <li>• Notify_Type</li> <li>• Event_Time_Stamps</li> <li>• Event_Detection_Enable</li> <li>• Event_Algorithm_Inhibit_Ref</li> <li>• Event_Algorithm_Inhibit</li> <li>• Property_List</li> </ul>	<ul style="list-style-type: none"> <li>• Description</li> <li>• Reliability</li> <li>• State_Text</li> </ul>	<ul style="list-style-type: none"> <li>• Object_Name</li> <li>• Present_Value</li> <li>• Description</li> <li>• Reliability</li> <li>• Out_of_Service</li> <li>• Number_of_States</li> <li>• Relinquish_Default</li> <li>• State_Text</li> <li>• Time_Delay</li> <li>• Notification_Class</li> <li>• Alarm_Values</li> <li>• Fault_Values</li> <li>• Event_Enable</li> <li>• Notify_Type</li> <li>• Event_Detection_Enable</li> <li>• Event_Algorithm_Inhibit_Ref</li> <li>• Event_Algorithm_Inhibit</li> </ul>	No	No
Notification Class	<ul style="list-style-type: none"> <li>• Object_Identifier</li> <li>• Object_Name</li> <li>• Object_Type</li> <li>• Notification_Class</li> <li>• Priority</li> <li>• Ack_Required</li> <li>• Recipient_List</li> <li>• Property_List</li> </ul>	None	<ul style="list-style-type: none"> <li>• Object_Name</li> <li>• Priority</li> <li>• Ack_Required</li> <li>• Recipient_List</li> </ul>	No	No

## BACnet Data Points and Configuration Property Definitions

**Table 2. Descriptions and configurations (continued)**

Object Type	Required Properties	Properties Properties	Writable Properties <sup>(a)</sup>	Ability to Create	Ability to Delete
Schedule	<ul style="list-style-type: none"> <li>• Object_Identifier</li> <li>• Object_Name</li> <li>• Object_Type</li> <li>• Present_Value</li> <li>• Effective_Period</li> <li>• Schedule_Default</li> <li>• List_Of_Object_Property_Reference</li> <li>• Priority_For_Writing</li> <li>• Status_Flags</li> <li>• Reliability</li> <li>• Out_Of_Servi</li> <li>• Property_List</li> </ul>	<ul style="list-style-type: none"> <li>• Description</li> <li>• Weekly_Schedule</li> <li>• Exception_Schedule</li> </ul>	<ul style="list-style-type: none"> <li>• Object_Name</li> <li>• Description</li> <li>• Schedule_Default</li> <li>• List_of_Property_References</li> <li>• Weekly_Schedule</li> <li>• Exception_Schedule</li> <li>• Priority_for_Wri</li> <li>• Out_of_Service</li> </ul>	No	No
Trend	<ul style="list-style-type: none"> <li>• Object_Identifier</li> <li>• Object_Name</li> <li>• Object_Type</li> <li>• Enable</li> <li>• Start_Time</li> <li>• Stop_Time</li> <li>• Log_Device_Object_Property</li> <li>• Log_Interval</li> <li>• COV_Resubscription_Interval</li> <li>• Stop_When_Full</li> <li>• Buffer_Size</li> <li>• Log_Buffer</li> <li>• Record_Count</li> <li>• Total_Record_Count</li> <li>• Logging_Type</li> <li>• Notification_Threshold</li> <li>• Records_Since_Notification</li> <li>• Last_Notify_Record</li> <li>• Event_State</li> <li>• Status_Flags</li> <li>• Notification_Class</li> <li>• Event_Enable</li> <li>• Acked_Transitions</li> <li>• Notify_Type</li> <li>• Event_Time_Stamps</li> <li>• Event_Detection_Enable</li> <li>• Property_List</li> </ul>	<ul style="list-style-type: none"> <li>• Reliability</li> </ul>	<ul style="list-style-type: none"> <li>• Object_Name</li> <li>• Enable</li> <li>• Start_Time</li> <li>• Stop_Time</li> <li>• Log_Device_Object_Property</li> <li>• Log_Interval</li> <li>• COV_Resubscription_Interval</li> <li>• Stop_When_Full</li> <li>• Buffer_Size</li> <li>• Record_Count</li> <li>• Logging_Type</li> <li>• Notification_Threshold</li> <li>• Notification_Class</li> <li>• Event_Enabl</li> <li>• Notify_Type</li> </ul>	No	No

<sup>(a)</sup> The following properties are only writable when the Out\_Of\_Service property is set to TRUE: **Reliability** property for all objects and the Present\_Value property for the Analog Input, Binary Input, and Multistate Input objects.



# BACnet

## Data Link layer Options

Data Link Layer Description	Supported
BACnet IP, (Annex J), Foreign Device	<input type="checkbox"/>
ISO 8802-3, Ethernet (Clause 7)(10Base2, 10Base5, 10BaseT, Fiber)	<input type="checkbox"/>
ANSI/ATA 878.1, 2.5 Mb ARCNET (Clause 8)	<input type="checkbox"/>
ANSI/ATA 878.1, RS-485 ARCNET (Clause 8), Baud Rate(s)	<input type="checkbox"/>
EIA-485 Token Passing, Requestor (Clause 9), Baud Rate(s): 9600, 19200, 38400, and 76800	<input checked="" type="checkbox"/>
EIA-485 Token Passing, Non-requestor (Clause 9)	<input type="checkbox"/>
Point-to-Point, EIA 232 (Clause 10), Baud Rate(s): 9600, 19200, 38400	<input type="checkbox"/>
Point-to-Point, Modem (Clause 10), Baud Rate(s): 9600, 19200, 38400	<input type="checkbox"/>
LonTalk, (Clause 11), Medium	<input type="checkbox"/>
BACnet/ZigBee (Annex O) <sup>(a)</sup>	<input checked="" type="checkbox"/>
Other	<input type="checkbox"/>

<sup>(a)</sup> The BCI2-C does not support BACnet/Zigbee communications.

## Device Address Binding

Device Address Binding	Supported
Is static device binding supported?	Yes <input type="checkbox"/> No <input checked="" type="checkbox"/>

## Networking Options

Networking Descriptions	Supported
Router	<input type="checkbox"/>
Annex H, BACnet Tunneling	<input type="checkbox"/>
BACnet/IP Broadcast Management Device (BBMD)	<input type="checkbox"/>
Does the BBMD Support Registrations by Foreign Devices?	<input type="checkbox"/>

## Character Sets

Indicating support for multiple characters sets does not imply that all character sets are supported simultaneously. Maximum supported string length is 64 bytes (*any character set*).

Character Set Descriptions	Supported
ISO-10646 UTF-8	<input checked="" type="checkbox"/>
IBM/Microsoft DBCS	<input type="checkbox"/>
JIS C 6226	<input type="checkbox"/>
ISO 10646 (UCS-4)	<input type="checkbox"/>
ISO 10646 (UCS2)	<input type="checkbox"/>
ISO 8859-1	<input type="checkbox"/>



# Object Data Points and Diagnostic Data Points

For quick reference, the following tables are listed two different ways. through are listed by input/output type and sorted by object identifier. These tables provide the user with the units type for each object type. and are sorted by object name and provide a complete list of object names, types, values/ranges, and descriptions. Not all points are available to the user. The available data points are defined during self-configuration and are dependent on the type of equipment.

**Note:** The When Exists column details the criteria in which the BCI2-R product will have specific objects instantiated based on the features and options that have been selected.

**Table 3. Analog output**

Object Identifier	Object Name	Description	Units of Measure IP/SI	Valid Range (F°)	Refresh Rate (Sec.)	When Exists
AO 1	Economizer Minimum Position Setpoint BAS	BAS supplied economizer position minimum setpoint value	Percent	0 to 50	NA	With RTEM installed
AO 2	Space Temperature Setpoint BAS	Base value to calculate setpoints in occupied and standby modes	Fahrenheit Celsius	50.0 to 90.0 10.0 to 32.2	NA	Always
AO 4	Morning Warmup Setpoint BAS	BAS supplied temperature setpoint used in morning warmup mode	Fahrenheit Celsius	50.0 to 90.0 10.0 to 32.2	NA	With RTAM and heat installed
AO 5	Daytime Warmup Terminate Temperature Setpoint BAS	BAS supplied daytime warmup terminate temperature setpoint	Fahrenheit Celsius	50.0 to 90.0 10.0 to 32.2	NA	With RTAM and heat installed
AO 6	Discharge Air Cooling Setpoint BAS	BAS supplied discharge air temperature cooling setpoint value	Fahrenheit Celsius	40.0 to 80.0 4.4 to 26.7	NA	When configured for Multi-zone VAV or Single Zone VAV
AO 7	Discharge Air Heating Setpoint BAS	BAS supplied discharge air temperature heating setpoint value	Fahrenheit Celsius	50.0 to 158.0 10.0 to 70.0	NA	When configured for Multi-zone VAV, Single zone VAV, or with modulating heat
AO 8	Duct Static Pressure Setpoint BAS	BAS supplied duct static air pressure setpoint value	0.0 inH2O = 0 Pa 2.5 inH2O = 622 Pa	0.0 to 2.5	NA	With RTAM installed
AO 9	Space Static Pressure Setpoint BAS	BAS supplied space static air pressure setpoint value	-0.2 inH2O = -50 Pa 0.3 inH2O = 74 Pa	0.3 to -0.2	NA	With Modulating Power Exhaust and RTRM version 9 or higher installed
AO 10	Space Static Pressure BAS	BAS supplied space static air pressure sensor value	-0.67 inH2O = -167 Pa 0.67 inH2O = 167 Pa	-0.67 to 0.67	900	With Modulating Power Exhaust



## Object Data Points and Diagnostic Data Points

**Table 3. Analog output (continued)**

Object Identifier	Object Name	Description	Units of Measure IP/SI	Valid Range (F°)	Refresh Rate (Sec.)	When Exists
AO 11	Space Temperature BAS	BAS supplied space air temperature sensor value	Fahrenheit Celsius	-40.0 to 150.0 -40.0 to 65.6	900	Always
AO 14	Outdoor Air Temperature BAS	BAS supplied outdoor air temperature sensor value	Fahrenheit Celsius	-40.0 to 158.0 -40.0 to 70.0	900	Always
AO 15	Outdoor Air Humidity BAS	BAS supplied outdoor air humidity sensor value	Percent	0 to 100	900	Always
AO 16	Outdoor Air Minimum Flow Setpoint BAS	BAS supplied minimum outdoor airflow setpoint	0 CFM = 0 l/s (litres/second) 40000 CFM = 18878 l/s	0 to 40,000	NA	With RTVM version 3 or greater installed and RTRM firmware 9 or greater installed
AO 18	Space CO <sub>2</sub> Concentration BAS	BAS supplied space CO <sub>2</sub> sensor value	Part-per-million mg/kg	0.0 to 2000	900	Always
AO 19	Cool Capacity Enable Setpoint BAS	BAS supplied cooling demand limit capacity setpoint value	Percent	0 to 100	NA	Always
AO 20	Heat Capacity Enable Setpoint BAS	BAS supplied heating demand limit capacity setpoint value	Percent	0 to 100	NA	With all heat types
AO 21	Space Dehumidification Setpoint BAS	BAS supplied space dehumidification setpoint value	Percent	40 to 65	NA	With RTDM installed
AO 23	Discharge Air Reheat Setpoint BAS	BAS supplied discharge air reheat setpoint value	Fahrenheit Celsius	65.0 to 80.0 18.3 to 26.7	NA	With RTDM installed
AO 25	Space Humidity BAS	BAS supplied space humidity sensor value	Percent	10 to 100	900	With RTDM installed
AO 29	Occupied Offset	Offset used to calculate setpoints in occupied mode	Fahrenheit Celsius	1.0 to 5.0 0.6 to 2.8	NA	Always
AO 30	Standby Offset	Offset value used to calculate setpoints in standby mode	Fahrenheit Celsius	1.0 to 10.0 0.06 to 5.6	NA	Always
AO 31	Unoccupied Cooling Setpoint	Cooling temperature setpoint used or control in unoccupied mode.	Fahrenheit Celsius	50 to 90 10.0 to 32.2	NA	Always
AO 32	Unoccupied Heating Setpoint	Heating temperature setpoint used for control in unoccupied mode	Fahrenheit Celsius	50.0 to 90.0 10.0 to 32.2	NA	Always
AO 33	Exhaust or Return Fan Configuration	Sets the equipment exhaust or return fan type	NA	1.0 to 255	NA	Always
AO 34	Power Exhaust Enable Setpoint BAS	BAS supplied power exhaust enabled setpoint value	Percent	0.0 to 100	NA	With RTEM installed

## Object Data Points and Diagnostic Data Points

**Table 3. Analog output (continued)**

Object Identifier	Object Name	Description	Units of Measure IP/SI	Valid Range (F°)	Refresh Rate (Sec.)	When Exists
AO 35	Space Cooling Setpoint High Limit BAS	High limit value to clamp the space cooling setpoint	Fahrenheit Celsius	50.0 to 90.0 10.0 to 32.2	NA	Always
AO 36	Space Cooling Setpoint Low Limit BAS	Low limit value to clamp the space cooling setpoint	Fahrenheit Celsius	50.0 to 90.0 10.0 to 32.2	NA	Always
AO 37	Space Heating Setpoint High Limit BAS	High limit value to clamp the space heating setpoint	Fahrenheit Celsius	50.0 to 90.0 10.0 to 32.2	NA	Always
AO 38	Space Heating Setpoint Low Limit BAS	Low limit value to clamp the space heating setpoint	Fahrenheit Celsius	50.0 to 90.0 10.0 to 32.2	NA	Always
AO 41	Economizing Temperature Enable Setpoint	Temperature setpoint below which economizing can be used	Fahrenheit Celsius	50.0-140.0 10.0-60.0	NA	With RTEM installed
AO 42	Economizing Enthalpy Enable Setpoint	Enthalpy setpoint below which economizing can be used	Btu per lb	19.0-28.0	NA	With RTEM installed
AO 43	Daytime Warmup Initiate Temperature Setpoint BAS	BAS supplied daytime warmup Initiate temperature setpoint	Fahrenheit	50.0 to 87.0	NA	RTAM is present and heat is present
AO 44	Supply Fan Minimum Speed BAS	BAS supplied minimum fan speed	Percent	0.0 to 100.0	NA	Supply fan is not single speed
AO 45	Supply Fan Maximum Speed BAS	BAS supplied maximum fan speed	Percent	0.0 to 100.0	NA	Supply fan is not single speed
AO 46	Outdoor Air Temperature Heating Lockout Low Limit	Temperature at which Mechanical Heating will be locked out on a Heat Pump	Fahrenheit	0.0 to 45.0	NA	Configured as a Heat Pump

**Table 4. Analog input**

Object Identifier	Object Name	Description	Units of Measure IP/SI	When Exists
AI 1	Cooling Capacity Status	Indicates the unit cooling capacity being utilized	Percent	Always
AI 2	Heat Primary Capacity Status	Indicates the unit primary heating capacity being utilized	Percent	With modulating heat
AI 3	Heat Secondary Capacity Status	Indicates the unit secondary heating capacity being utilized	Percent	With RTDM installed
AI 5	Reheat Capacity Status	Indicates the unit reheat heating capacity being utilized	Percent	With RTDM installed
AI 6	Filter Runtime Hours	Indicates the number of hours air has flowed through the filter	Hours	Always
AI 7	Supply Fan Speed Command	Indicates the unit commanded supply fan speed	Percent	Always



## Object Data Points and Diagnostic Data Points

**Table 4. Analog input (continued)**

Object Identifier	Object Name	Description	Units of Measure IP/SI	When Exists
AI 8	Exhaust Fan Speed Command	Indicates the unit commanded exhaust fan speed	Percent	With RTEM installed
AI 9	Exhaust Damper Position Status	Indicates the unit exhaust damper position	Percent	Always
AI 11	Outdoor Air Damper Position Status	Indicates the unit outdoor air damper position	Percent	Always
AI 15	Space Temperature Active	The space temperature currently used for unit control	Fahrenheit Celsius	Always
AI 16	Space Humidity Active	The space humidity value from a unit-mounted control	Percent-relative-humidity	With RTOM installed
AI 18	Outdoor Air Temperature Active	The outdoor air temperature currently used for unit control	Fahrenheit Celsius	With RTEM installed
AI 20	Outdoor Air Humidity Active	The outdoor air humidity value used for unit control	Percent-relative-humidity	With RTEM installed
AI 24	Discharge Air Temperature Active	The discharge air temperature currently used for unit control	Fahrenheit Celsius	With RTOM installed
AI 25	Mixed Air Temperature	The mixed air temperature value from a unit-mounted sensor	Fahrenheit Celsius	Always
AI 26	Return Air Temperature	The return air temperature value from a unit-mounted sensor	Fahrenheit Celsius	With RTEM installed
AI 28	Duct Static Pressure Active	Duct static air pressure value currently being used for unit control	0.0 inH2O = 0 Pa 7.9 inH2O = 1967 Pa	With RTAM installed
AI 31	Space Static Air Pressure Active	Space static air pressure value being used for unit control	-0.67 inH2O = -167 Pa 0.67 inH2O = 167 Pa	When configured for Modulating Powered Exhaust and Version 9 or greater RTRM Firmware installed
AI 32	Space CO <sub>2</sub> Concentration Active	Space CO <sub>2</sub> concentration being used for unit control	Part-per-million mg/kg	With RTEM installed
AI 34	Outdoor Air Flow Active	Outdoor airflow utilized by the unit	0 CFM = 0 l/s (liters/second) 65535 CFM = 30929 l/s	With RTVM version 3 or greater installed and RTRM firmware 9 or greater installed
AI 48	Duct Static Pressure Setpoint Active	Duct static pressure setpoint value being used for unit control	0.0 inH2O = 0 Pa 5.1 inH2O = 1270 Pa	With Multi-zone VAV and RTAM installed or Single-zone VAV
AI 50	Space Temperature Setpoint Active	Space temperature setpoint value being used for unit control	Fahrenheit Celsius	Always
AI 52	Discharge Air Temperature Setpoint Active	Discharge air temperature setpoint value being used for unit control	Fahrenheit Celsius	When configured for Multi-zone VAV or Single zone VAV
AI 54	Morning Warmup Temperature Setpoint Active	The air temperature setpoint used during morning warmup mode	Fahrenheit Celsius	When RTAM installed and heat installed
AI 57	Outdoor Air Minimum Flow Setpoint Active	The minimum outdoor airflow setpoint being utilized by the unit	0 CFM = 0 l/s (liters/second) 65000 CFM = 30676 l/s	With RTVM version 3 or greater installed and RTRM firmware 9 or greater installed
AI 58	Dehumidification High Limit Setpoint	Humidity setpoint value that starts dehumidification control	Percent	With RTDM installed
AI 61	Discharge Air Reheat Setpoint Active	Indicates the active supply air reheat temperature setpoint	Fahrenheit Celsius	With RTDM installed

## Object Data Points and Diagnostic Data Points

**Table 4. Analog input (continued)**

Object Identifier	Object Name	Description	Units of Measure IP/SI	When Exists
AI 71	Exhaust Enable Damper Position Setpoint Status	Exhaust air damper minimum position to enable exhaust sequence	Percent	With RTEM installed
AI 74	Space Temperature Cooling Setpoint Input	Cooling temperature setpoint from space sensor module	Fahrenheit Celsius	Always
AI 75	Space Temperature Heating Setpoint Input	Heating temperature setpoint from space sensor module	Fahrenheit Celsius	Always
AI 78	Space Temperature Setpoint Local	Will report the locally derived setpoint from the RTRM. ReliaTel will use this setpoint if Space Temperature BAS (AO 2) is Out of Service, or if wireless is not being sent.	Fahrenheit Celsius	Always
AI 79	Dehumidification Capacity Status	Indicates the unit dehumidification capacity being utilized	Percent	With RTDM installed
AI 80	Cabinet Style	Different cabinet types: 6 = Voyager/Precedent/Odyssey, 22 = Voyager Commercial	NA	Always
AI 81	Cool Type	Describes the different cooling types: 7 = 1-Stage DX, 8 = 2-Stage DX, 9 = 3-Stage DX	NA	Always
AI 82	Preheat Type	Describes the different heating types: 129 = None 19 = 1-Stage DX 20 = 2-Stage DX 130 = Modulating Hot Water 134 = Modulating Electric 135 = 1-Stage Electric 136 = 2-Stage Electric 140 = 1-Stage Gas 141 = 2-Stage Gas 142 = Modulating Gas	NA	Always
AI 83	Reheat Type	Describes the different reheat types: 129 = None 17 = Hot Gas 19 = 1-Stage DX 20 = 2-Stage DX 130 = Modulating Hot Water 134 = Modulating Electric 135 = 1-Stage Electric 136 = 2-Stage Electric 140 = 1-Stage Gas 141 = 2-Stage Gas 142 = Modulating Gas	NA	Always
AI 86	Economizer Minimum Position Setpoint Local	Indicates the local economizer minimum position setpoint	Percent	With RTEM installed
AI 87	Space Temperature Local	The space air temperature measured by a unit-mounted sensor	Fahrenheit Celsius	Always
AI 88	Unit Energy Demand	Indicates the current heat/cool energy demand of the unit	Percent	Always



## Object Data Points and Diagnostic Data Points

**Table 4. Analog input (continued)**

Object Identifier	Object Name	Description	Units of Measure IP/SI	When Exists
AI 89	Supply Fan Type	Describes the different supply fan types: 2 = 1-Speed Supply Fan 3 = 2-Speed Supply Fan 4 = 3-Speed Supply Fan 7 = 4-Speed Supply Fan 8 = 5-Speed Supply Fan 5 = Modulating Inlet Guide Vanes Supply Fan 6 = Variable Speed Supply Fan 35 = SZVAV 2-Speed Supply Fan 36 = SZVAV 3-Speed Supply Fan 39 = SZVAV 4-Speed Supply Fan 40 = SZVAV 5-Speed Supply Fan 38 = SZVAV Variable Speed Supply Fan	NA	Always
AI 90	Exhaust or Return Fan Type	Describes the different exhaust or return fan types: 1 = None 2 = 1-Speed Exhaust Fan 7 = 1-Speed Exhaust Fan with Modulating Exhaust Damper	NA	Always
AI 91	RTRM Major Version	Major software version number of the RTRM module	NA	Always
AI 92	RTRM Minor Version	Minor software version number of the RTRM module	NA	Always
AI 93	RTOM Major Version	Major software version number of the RTOM module	NA	With RTOM installed
AI 94	RTOM Minor Version	Minor software version number of the RTOM module	NA	With RTOM installed
AI 95	BCI2-R Major Version	Major software version number of the BCI2-R module	NA	Always
AI 96	BCI2-R Minor Version	Minor software version number of the BCI2-R module	NA	Always
AI 97	RTAM Major Version	Major software version number of the RTAM module	NA	With RTAM installed
AI 98	RTAM Minor Version	Minor software version number of the RTAM module	NA	With RTAM installed
AI 99	RTEM Major Version	Major software version number of the RTEM module	NA	With RTEM installed
AI 100	RTEM Minor Version	Minor software version number of the RTEM module	NA	With RTEM installed
AI 101	RTDM Major Version	Major software version number of the RTDM module	NA	With RTDM installed and RTRM version 9 or higher installed
AI 102	RTDM Minor Version	Minor software version number of the RTDM module	NA	With RTDM installed and RTRM version 9 or higher installed
AI 103	RTVM Major Version	Major software version number of the RTVM module	NA	With RTVM installed and RTRM version 9 or higher installed
AI 104	RTVM Minor Version	Minor software version number of the RTVM module	NA	With RTVM installed and RTRM version 9 or higher installed
AI 105	VSM Major Version	Major Software version number of the VSM module	NA	With VSM installed and RTRM version 15 or higher installed
AI 106	VSM Minor Version	Minor software version number of the VSM module	NA	With VSM installed and RTRM version 15 or higher installed
AI 107	Space Static Pressure Setpoint Active	Space pressure setpoint currently used for unit control	Inches-of-water	Always

## Object Data Points and Diagnostic Data Points

**Table 4. Analog input (continued)**

Object Identifier	Object Name	Description	Units of Measure IP/SI	When Exists
AI 108	Tracer TD5 Major Version	Major Software version number of the TD5 module	NA	With TD5 installed and RTRM version 15 or higher installed
AI 109	Tracer TD5 Minor Version	Minor Software version number of the TD5 module	NA	With TD5 installed and RTRM version 15 or higher installed

**Table 5. Analog value**

Object Identifier	Object Name	Description	Units	Valid Range
AV 1	Filter Runtime Hours Setpoint	The setpoint value used by the filter run hours calculation.	Hours	0 to 10,000

**Table 6. Multistate output**

BCI2-R Object Identifier	Object Name	Description	Object States *not all states apply to all equipment	When Exists
MO 1	Economizer Airside Enable BAS	Command the state of the airside economizer system	1 = Disabled 2 = Enabled 3 = Auto	With RTEM Installed
MO 2	Emergency Override Command	Command the unit into an emergency mode of operation	1 = Normal 2 = Pressurize 3 = Depressurize 4 = Purge 5 = Shutdown 6 = Fire	Always
MO 7	Occupancy Request	Command the unit into an occupancy mode.	1 = Occupied 2 = Unoccupied 3 = Occupied Bypass 4 = Occupied Standby	Always
MO 8	Heat Cool Mode Request BAS	Command the unit to a specific application mode.	1 = Auto 2 = Heat 3 = Morning Warmup 4 = Cool 5 = Night Purge 6 = Precool 7 = Off 8 = Test 9 = Emergency Heat 10 = Fan Only 11 = Free Cool 12 = Ice Making 13 = Max Heat 14 = Economy Mode 15 = Dehumidifying 16 = Calibrate	Always

## Object Data Points and Diagnostic Data Points

**Table 7. Multistate input**

BCI2-R Object Identifier	Object Name	Description	Object States *not all states apply to all equipment	When Exists
MI 2	Trane Unit Type	General description of the equipment-type classification.	1 = 1 Heat/1 Cool 2 = Heat Pump 3 = Blower Coil 4 = Unit Ventilator 5 = Fan Coil 6 = Rooftop 7 = Air Handler 8 = Vertical Self Contained 9 = Unitary 10 = VAV Box 11 = Fan Coil	Always
MI 9	Economizer Type	General description of the equipment economizer system.	1 = None 2 = 2 Position Ventilation 3 = Modulation Economizer 4 = 2 Position Ventilation/Waterside Economizer 5 = Waterside Economizer 6 = Airside/Waterside Economizer 7 = TRAQ Damper 8 = Airside Economizer and TRAQ Damper/Sensor 9 = Waterside Economizer and TRAQ Damper/Sensor 10 = Airside/Waterside Economizer and TRAQ Damper/Sensor	With RTEM installed
MI 17	Cooling Reset Type Status	Indicates the type of cooling reset.	1 = None 2 = Outdoor Air 3 = Zone	With Multi-zone VAV and RTAM installed or Single-zone VAV
MI 19	Heat Cool Mode Status/ Application Mode Status	Heat Cool Mode Status: matches the defined system display name and the display name used in TU. Application Mode Status: the point name used in the device.	1 = Auto 2 = Heat 3 = Morning Warm-up 4 = Cool 5 = Night Purge 6 = Pre Cool 7 = Off 8 = Test 9 = Emergency Heat 10 = Fan Only 11 = Free Cool 12 = Ice-Making 13 = Max Heat 14 = Economy Mode 15 = Dehumidifying 16 = Calibrate	Always
MI 20	Occupancy Status	Indicates the current occupancy mode of the unit.	1 = Occupied 2 = Unoccupied 3 = Occupied Bypass 4 = Occupied Standby	Always
MI 21	Unit Stop Source	Source of the stop command that turned off the equipment.	1 = None 2 = Emergency Stop 3 = Drain Pan Overflow 4 = Local HI Stop	Always
MI 22	Cooling Setpoint Source	Indicates the source of the space cooling setpoint.	1 = RTM Zone Sensor 2 = Night Setback Panel 3 = Human Interface 4 = GBAS 0-5V 5 = BAS/Network 6 = GBAS 0-10V	Always

## Object Data Points and Diagnostic Data Points

**Table 7. Multistate input (continued)**

BCI2-R Object Identifier	Object Name	Description	Object States *not all states apply to all equipment	When Exists
MI 23	Heating Setpoint Source	Indicates the source of the space heating setpoint.	1 = RTM Zone Sensor 2 = Night Setback Panel 3 = Human Interface 4 = GBAS 0-5V 5 = BAS/Network 6 = GBAS 0-10V	Always
MI 24	Timed Override Status	Timed override request or cancel from zone sensor.	1 = Idle 2 = On 3 = Cancel	Always
MI 25	Cool Output 1	Indicates the commanded state of cooling output 1.	1 = Off 2 = On 3 = Not Present	Always
MI 26	Cool Output 2	Indicates the commanded state of cooling output 2.	1 = Off 2 = On 3 = Not Present	Always
MI 29	Heat Output 1	Indicates the commanded state of heating output 1.	1 = Off 2 = On 3 = Not Present	Always
MI 30	Heat Output 2	Indicates the commanded state of heating output 2.	1 = Off 2 = On 3 = Not Present	Always
MI 31	Heat Output 3	Indicates the commanded state of heating output 3.	1 = Off 2 = On 3 = Not Present	Always
MI 32	Heat Output 4	Indicates the commanded state of heating output 4.	1 = Off 2 = On 3 = Not Present	Always
MI 35	Primary Filter Status	Indicates the primary filter media state.	1 = Clean 2 = Dirty 3 = Not Present	Always
MI 37	Supply Fan Proving Status	Indicates the current state of the supply fan.	1 = Off 2 = On 3 = Not Present	Always
MI 38	Exhaust Fan Status	Indicates the commanded state of the exhaust fan.	1 = Off 2 = On 3 = Not Present	With RTEM Installed
MI 39	Exhaust Fan Proving Status	Indicates if the unit exhaust fan is off or on.	1 = Off 2 = On 3 = Not Present	With RTOM installed (Only activates with RTEM installed)
MI 41	Supply Fan Status	Indicates the state of the supply fan.	1 = Off 2 = On 3 = Not Present	Always
MI 43	Outdoor Damper Status	Indicates the operating state of the outdoor damper.	1 = At or Below Minimum Position 2 = Above Minimum Position 3 = Not Present	With RTEM Installed



## Object Data Points and Diagnostic Data Points

**Table 7. Multistate input (continued)**

BCI2-R Object Identifier	Object Name	Description	Object States *not all states apply to all equipment	When Exists
MI 44	Economizer System Status	Indicates the operating state of the waterside economizer system.	1 = Disabled 2 = Enabled 3 = Not Present	With RTEM Installed
MI 45	Service Test Status	Indicates the current Service Test state	1 = Inactive 2 = Fan On 3 = IGV Open 4 = IGV Close 5 = Min Vent 6 = Econ Open 7 = Cool 1 8 = Cool 2 9 = Cool 3 10 = Dehumidification/Reheat 11 = Heat 1 12 = Heat 2 13 = Heat 3 14 = Heat 4 15 = Defrost 16 = Emergency Heat	Always

**Table 8. Binary output**

Object Identifier	Description	Object Name	Relinquish Default	Object States	When Exists
BO 1	Command the unit to standalone- or BAS-controlled operation.	System Control Command	Inactive	Inactive = Standalone Control Active = BAS Control	Always
BO 5	Command the unit to prevent heating operation.	Heat Lockout Command	Inactive	Inactive = Allow Heating Active = Heating Locked Out	Always
BO 6	Command the unit to prevent cooling operation.	Cool Lockout Command	Inactive	Inactive = Allow Cooling Active = Cooling Locked Out	Always
BO 7	Command the unit to the minimum position operation.	Economizer Minimum Position Enable Command	Inactive	Inactive = Disabled Active = Enabled	With RTEM installed
BO 8	Command the unit supply fan to cycling or continuous operation.	Supply Fan Configuration Command	Inactive	Inactive = Auto Active = On	Always
BO 13	Command the unit to reset the accumulated filter run hours.	Filter Timer Reset	Inactive	Inactive = Accumulating Active = Reset	Always
BO 14	Command the unit to reset and clear diagnostics.	Reset Diagnostic	Inactive	Inactive = Normal Active = Reset	Always
BO 15	Command the operating state of the dehumidification system.	Dehumidification Enable Command	Active	Inactive = Disabled Active = Auto	With RTDM installed
BO 17	Command the unit to step through service test	Service Test Command	1 (Auto)	Inactive = Normal Active = Service test	Always
BO 18	Command the unit supply air tempering operation.	Supply Air Tempering Enable Command	Inactive	Inactive = Disabled Active = Enabled	With all heat types
BO 19	Command the unit compressor startup order	Lead-Lag Enable Command	Inactive	Inactive = Disabled Active = Enabled	Always

## Object Data Points and Diagnostic Data Points

**Table 8. Binary output (continued)**

Object Identifier	Description	Object Name	Relinquish Default	Object States	When Exists
BO 20	Command the unit morning warmup operation	Morning Warmup Enable Command	Inactive	Inactive = Disabled Active = Enabled	Always
BO 21	Command the unit daytime warmup operation	Daytime Warmup Enable Command	Inactive	Inactive = Disabled Active = Enabled	Always

**Table 9. Binary input**

Object Identifier	Object Name	Description	Object States	When Exists
BI 1	System Control Status	Indicates the control system currently in command of the unit.	Inactive = Standalone control Active = BAS control	Always
BI 2	Compressor Lockout Status	One or more compressors are locked out with no diagnostic.	Inactive = Normal Active = Locked Out	Always
BI 9	VAV Box Command	Indicates whether VAV boxes should be in control or wide open.	Inactive = Auto Active = Open	Multi-zone VAV and RTAM installed
BI 11	Service Test Mode Status	Indicates if the unit is in service test mode.	Inactive = Inactive Active = Active	Always
BI 15	Supply Fan Configuration Status	Indicates the supply fan configuration.	Inactive = Cycling Active = Continuous	Constant Volume
BI 22	Economizer Airside Enable Status	Indicates the status of the airside economizer system.	Inactive = Disabled Active = Enabled	With RTEM Installed
BI 165	Alarm Relay Output Status	Indicates the state of the alarm relay on the unit.	Inactive = De-energized Active = Energized	Always
BI 292	Supply Air Tempering Status	Indicates the status of the supply air tempering function.	Inactive = Inactive Active = Active	Always

**Table 10. Diagnostics, binary input**

Object Identifier	Object Name	Description	Notification Class	When Exists
BI 29	Diagnostic: Zone Temperature Sensor Failure	Diagnostic: Zone Temp Sensor Failure	002 – Service Required	Always
BI 30	Diagnostic: Supply Air Temp Sensor Fail	Diagnostic: Supply Air Temp Sensor Fail	002 – Service Required	Always
BI 32	Diagnostic: Outdoor Air Temperature Sensor Fail	Diagnostic: OA Temperature Sensor Fail	002 – Service Required	Always
BI 34	Diagnostic: Local Cool Setpoint Fail	Diagnostic: Local Cool Setpoint Fail	002 – Service Required	Always
BI 35	Diagnostic: Local Zone Heat Setpoint Fail	Diagnostic: Local Zone Heat Setpoint Fail	002 – Service Required	Always
BI 36	Diagnostic: SA Pressure Sensor Fail	Diagnostic: Supply Air Press Sensor Fail	002 – Service Required	Always
BI 37	Diagnostic: Outdoor Humidity Sensor Failure	Diagnostic: OA Humidity Sensor Failure	002 – Service Required	With RTEM installed
BI 38	Diagnostic: Local Emergency Stop Initiated	Diagnostic: Local Emergency Stop Initiated	001 – Critical	Always
BI 39	Diagnostic: Fan Failure	Diagnostic: Fan Failure	001 – Critical	With RTEM installed
BI 40	Diagnostic: Exhaust Fan Proving Failure	Diagnostic: Exhaust Fan Proving Failure	001 – Critical	With RTEM installed
BI 43	Diagnostic: Compressor 1 LPC Lockout	Diagnostic: Compressor 1 LPC Lockout	001 – Critical	Always



## Object Data Points and Diagnostic Data Points

**Table 10. Diagnostics, binary input (continued)**

Object Identifier	Object Name	Description	Notification Class	When Exists
BI 44	Diagnostic: Compressor 2 LPC Lockout	Diagnostic: Compressor 2 LPC Lockout	001 – Critical	Always
BI 45	Diagnostic: Coil Temp Sensor #1 Fail	Diagnostic: Coil Temp Sensor 1 Fail 1	002 – Service Required	Always
BI 46	Diagnostic: Coil Temp Sensor #2 Fail	Diagnostic: Coil Temp Sensor 2 Fail	002 – Service Required	Always
BI 47	Diagnostic: Compressor 1 HPC Lockout	Diagnostic: Compressor 1 HPC Lockout	001 – Critical	Always
BI 48	Diagnostic: Compressor 2 HPC Lockout	Diagnostic: Compressor 2 HPC Lockout	001 – Critical	Always
BI 51	Diagnostic: Heat Failure	Diagnostic: Heat Failure	003 – Advisory	Always
BI 54	Diagnostic: SA Pressure Setpoint Failure	Diagnostic: SA Pressure Setpoint Failure	002 – Service Required	Always
BI 55	Diagnostic: Space Pressure Setpoint Fail	Diagnostic: Space Pressure Setpoint Fail	002 – Service Required	Always
BI 56	Diagnostic: Space Pressure Sensor Fail	Diagnostic: Space Pressure Sensor Fail	002 – Service Required	Always
BI 57	Diagnostic: Return Air Temp Sensor Fail	Diagnostic: Return Air Temp Sensor Fail	002 – Service Required	With RTEM installed
BI 58	Diagnostic: Return Air Humidity Sensor Fail	Diagnostic: Return Air Humidity Sensor Fail	002 – Service Required	With RTEM installed
BI 59	Diagnostic: Auto - SA High Press Limit	Diagnostic: Auto - SA High Press Limit	002 – Service Required	Always
BI 74	Diagnostic: SA Temp Cool Setpoint Fail	Diagnostic: SA Temp Cool Setpoint Fail	002 – Service Required	Always
BI 75	Diagnostic: SA Temp Heat Setpoint Fail	Diagnostic: SA Temp Heat Setpoint Fail	002 – Service Required	Always
BI 76	Diagnostic: Dirty Filter	Diagnostic: Dirty Filter	003 – Advisory	Always
BI 83	Diagnostic: CO2 Sensor Failure	Diagnostic: CO2 Sensor Failure	002 – Service Required	With RTEM installed
BI 86	Diagnostic: Velocity Press Sensor Fail	Diagnostic: Velocity Press Sensor Fail	002 – Service Required	With RTVM version 3 or greater installed
BI 95	Diagnostic: Mixed Air Temp Sensor Failure	Diagnostic: Mixed Air Temp Sensor Failure	002 – Service Required	With RTEM installed
BI 106	Diagnostic: Space Humidity Sensor Fail	Diagnostic: Space Humidity Sensor Fail	002 – Service Required	With RTEM installed
BI 107	Diagnostic: Entering Evap Temp Sensor Fail	Diagnostic: Entering Evap Temp Sensor Fail	002 – Service Required	Always
BI 123	Diagnostic: SA Reheat Setpoint Failure	Diagnostic: SA Reheat Setpoint Failure	002 – Service Required	Always
BI 125	Diagnostic: Dehumid Setpoint Failure	Diagnostic: Dehumid Setpoint Failure	002 – Service Required	With RTOM installed
BI 147	Diagnostic: Maintenance Required	Diagnostic: Maintenance Required	002 – Service Required	Always
BI 148	Diagnostic: Unit Communications Failure	Diagnostic: Unit Communications Failure	002 – Service Required	Always
BI 151	Diagnostic: Drain Pan Overflow	Diagnostic: Drain Pan Overflow	004 – Information	With RTOM installed
BI 239	Diagnostic: Morning Warmup Setpoint Fail	Diagnostic: Morning Warmup Setpoint Fail	002 – Service Required	Always
BI 242	Diagnostic: Min OA Flow Setpoint Fail	Diagnostic: Min OA Flow Setpoint Fail	002 – Service Required	With RTVM installed

## Object Data Points and Diagnostic Data Points

**Table 10. Diagnostics, binary input (continued)**

<b>Object Identifier</b>	<b>Object Name</b>	<b>Description</b>	<b>Notification Class</b>	<b>When Exists</b>
BI 244	Diagnostic: Comp 1 Disable Input LPC	Diagnostic: Comp 1 Disable Input LPC	004 – Information	Always
BI 245	Diagnostic: Comp 2 Disable Input LPC	Diagnostic: Comp 2 Disable Input LPC	004 – Information	Always
BI 246	Diagnostic: Smoke Detector	Diagnostic: Smoke Detector	004 – Information	With RTOM installed
BI 247	Diagnostic: FroStat Trip	Diagnostic: FroStat Trip	004 – Information	With RTOM installed
BI 248	Diagnostic: Demand Defrost Fault A	Diagnostic: Demand Defrost Fault A	004 – Information	With Heat Pump installed
BI 249	Diagnostic: Demand Defrost Fault B	Diagnostic: Demand Defrost Fault B	004 – Information	With Heat Pump installed
BI 250	Diagnostic: Demand Defrost Fault C	Diagnostic: Demand Defrost Fault C	004 – Information	With Heat Pump installed
BI 251	Diagnostic: Demand Defrost Fault D	Diagnostic: Demand Defrost Fault D	004 – Information	With Heat Pump installed
BI 252	Diagnostic: Default Defrost Flag	Diagnostic: Default Defrost Flag	004 – Information	With Heat Pump installed
BI 253	Diagnostic: Vent Override - Exhaust	Diagnostic: Vent Override - Exhaust	004 – Information	With RTOM installed
BI 254	Diagnostic: Vent Override - Purge	Diagnostic: Vent Override - Purge	004 – Information	With RTOM installed
BI 255	Diagnostic: Vent Override - Pressurize	Diagnostic: Vent Override - Pressurize	004 – Information	With RTOM installed
BI 256	Diagnostic: Freezestat Tripped	Diagnostic: Freezestat Tripped	004 – Information	With RTOM installed
BI 257	Diagnostic: CO2 Setpoint Failure	Diagnostic: CO2 Setpoint Failure	004 – Information	With RTEM installed
BI 258	Diagnostic: Heating High Temp Limit Open	Diagnostic: Heating High Temp Limit Open	004 – Information	With Gas Heat installed
BI 259	Diagnostic: Flame Rollout Switch Open	Diagnostic: Flame Rollout Switch Open	004 – Information	With Gas Heat installed
BI 260	Diagnostic: Inducer Proving Switch Fail	Diagnostic: Inducer Proving Switch Fail	004 – Information	With Gas Heat installed
BI 261	Diagnostic: No Flame Sensed on heat call	Diagnostic: No Flame Sensed on heat call	004 – Information	With Gas Heat installed
BI 262	Diagnostic: Flame Sensed with Gas Valve Off	Diagnostic: Flame Sensed with Gas Valve Off	004 – Information	With Gas Heat installed
BI 263	Diagnostic: Gas Heat Module Failure	Diagnostic: Gas Heat Module Failure	004 – Information	Always
BI 264	Diagnostic: Economizer Actuator Fault	Diagnostic: Economizer Actuator Fault	004 – Information	Always
BI 265	Diagnostic: SA Reset Amount Failure	Diagnostic: SA Reset Amount Failure	004 – Information	With RTOM installed
BI 266	Diagnostic: SA Reset Setpoint Failure	Diagnostic: SA Reset Setpoint Failure	004 – Information	With RTAM installed
BI 267	Diagnostic: SA Pressure Dead Band Failure	Diagnostic: SA Pressure Dead Band Failure	004 – Information	With RTAM installed
BI 268	Diagnostic: SA Pressure PWM Fault	Diagnostic: SA Pressure PWM Fault	004 – Information	With RTAM installed
BI 269	Diagnostic: Comp 1 Disable Input HPC	Diagnostic: Comp 1 Disable Input HPC	004 – Information	Always
BI 270	Diagnostic: Comp 2 Disable Input HPC	Diagnostic: Comp 2 Disable Input HPC	004 – Information	Always



## Object Data Points and Diagnostic Data Points

**Table 10. Diagnostics, binary input (continued)**

Object Identifier	Object Name	Description	Notification Class	When Exists
BI 271	Diagnostic: CO2 Low Limit Setpoint Fault	Diagnostic: CO2 Low Limit Setpoint Fault	004 – Information	With RTEM installed
BI 272	Diagnostic: RTOM Comm Fail	Diagnostic: RTOM Comm Fail	004 – Information	With RTOM installed
BI 273	Diagnostic: RTEM Comm Fail	Diagnostic: RTEM Comm Fail	004 – Information	With RTEM installed
BI 274	Diagnostic: RTAM Comm Fail	Diagnostic: RTAM Comm Fail	004 – Information	With RTAM installed
BI 275	Diagnostic: RTVM Comm Fail	Diagnostic: RTVM Comm Fail	004 – Information	With RTVM installed
BI 276	Diagnostic: VSM Comm Fail	Diagnostic: VSM Communication Fail	004 – Information	With VSM installed
BI 277	Diagnostic: RTDM Comm Fail	Diagnostic: RTDM Comm Fail	004 – Information	With RTDM installed
BI 278	Diagnostic: Space Press Deadband Fail	Diagnostic: Space Press Deadband Fail	004 – Information	Always
BI 279	Diagnostic: Mod Dehumid Config Error	Diagnostic: Mod Dehumid Config Error	004 – Information	Always
BI 280	Diagnostic: Demand Defrost Fault A Ckt 2	Diagnostic: Demand Defrost Fault A Ckt 2	004 – Information	With heat pump installed
BI 281	Diagnostic: Demand Defrost Fault B Ckt 2	Diagnostic: Demand Defrost Fault B Ckt 2	004 – Information	With Heat Pump installed
BI 282	Diagnostic: Demand Defrost Fault C Ckt 2	Diagnostic: Demand Defrost Fault C Ckt 2	004 – Information	With Heat Pump installed
BI 283	Diagnostic: Defrost Default Mode Ckt 2	Diagnostic: Defrost Default Mode Ckt 2	004 – Information	With Heat Pump installed
BI 284	Diagnostic: Demand Defrost Fault A Ckt 1	Diagnostic: Demand Defrost Fault A Ckt 1	004 – Information	With Heat Pump installed
BI 285	Diagnostic: Demand Defrost Fault B Ckt 1	Diagnostic: Demand Defrost Fault B Ckt 1	004 – Information	With Heat Pump installed
BI 286	Diagnostic: Demand Defrost Fault C Ckt 1	Diagnostic: Demand Defrost Fault C Ckt 1	004 – Information	With Heat Pump installed
BI 287	Diagnostic: Defrost Default Mode Ckt 1	Diagnostic: Defrost Default Mode Ckt 1	004 – Information	With Heat Pump installed
BI 288	Diagnostic: Exhaust Fan Setpoint Failure	Diagnostic: Exhaust Fan Setpoint Failure	004 – Information	With RTOM installed
BI 289	Diagnostic: Discharge Air Heat Setpoint Failure	Diagnostic: Discharge Air Heat Setpoint Failure	004 – Information	With RTOM installed
BI 290	Diagnostic: IGN1 Communications Timed out	Diagnostic: IGN1 Communications Timed out	004 – Information	With Gas Heat installed
BI 291	Diagnostic: IGN2 Communications Timed out	Diagnostic: IGN2 Communications Timed out	004 – Information	With Gas Heat installed
BI 293	Diagnostic: DCV Min Position Setpoint Fail	Diagnostic: DCV Min Position Setpoint Fail	004 – Information	With RTEM installed
BI 294	Diagnostic: Design Min Position Setpoint Fail	Diagnostic: Design Min Position Setpoint Fail	004 – Information	With RTEM installed
BI 295	Diagnostic: Enthalpy Setpoint Fail	Diagnostic: Enthalpy Setpoint Fail	004 – Information	Always
BI 296	Diagnostic: Design Min Position at Minimum Fan Speed Fail	Diagnostic: Design Min Position at Minimum Fan Speed Fail	004 – Information	With RTVM installed
BI 297	Diagnostic: DCV Min Position at Minimum Fan Speed	Diagnostic: DCV Min Position at Minimum Fan Speed	004 – Information	With RTVM installed
BI 298	Diagnostic: Design Min Position at Midpoint Fan Speed Fail	Diagnostic: Design Min Position at Midpoint Fan Speed Fail	004 – Information	With RTVM installed

## Object Data Points and Diagnostic Data Points

**Table 10. Diagnostics, binary input (continued)**

Object Identifier	Object Name	Description	Notification Class	When Exists
BI 299	Diagnostic: Compressor 3 HPC Lockout Status	Diagnostic: Compressor 3 HPC Lockout Status	001 - Critical	With Compressor 3 or VSPD compressor and RTRM 16 or higher installed
BI 300	Diagnostic: Compressor 3 LPC Lockout Status	Diagnostic: Compressor 3 LPC Lockout Status	001 - Critical	With Compressor 3 or VSPD compressor and RTRM 16 or higher installed
BI 301	Diagnostic: Compressor 3 HPC Disable	Diagnostic: Compressor 3 HPC Disable	004 - Information	With Compressor 3 or VSPD compressor and RTRM 16 or higher installed
BI 302	Diagnostic: Comp 3 Disable Input LPC	Diagnostic: Compressor 3 Disable Input LPC	004 - Information	With Compressor 3 or VSPD compressor and RTRM 16 or higher installed
BI 303	Diagnostic: Compressor Drive Fault	Diagnostic: Compressor Drive Fault	001 - Critical	With VSPD compressor and RTRM 16 or higher installed
BI 304	Diagnostic: Compressor Drive Lockout	Diagnostic: Compressor Drive Lockout	001 - Critical	With Compressor 3 and RTRM 16 or higher installed
BI 305	Diagnostic: Unit Economizing When It Should Not	Diagnostic: Unit Economizing When It Should Not	004 - Information	With RTEM 3 or higher installed and RTRM 16 or higher installed
BI 306	Diagnostic: Unit Not Economizing When It Should	Diagnostic: Unit Not Economizing When It Should	004 - Information	With RTEM 3 or higher installed and RTRM 16 or higher installed
BI 307	Diagnostic: Excessive Air	Diagnostic: Excessive Air	004 - Information	With RTRM 16 or higher installed
BI 308	Diagnostic: Air Damper Not Modulating	Diagnostic: Damper NOT Modulating	004 - Information	With RTRM 16 or higher installed
BI 309	Diagnostic: TD5 Comm Fail	Diagnostic: Tracer TD5 Communication Fail	004 - Information	With TD5 installed and RTRM 15 or higher installed
BI 310	Diagnostic: Mixed Air Temp Low Limit Cycle Active	Diagnostic: Mixed Air Temp Low Limit Cycle Active	004 - Information	Always
BI 311	Diagnostic: Supply Airflow Sensor Fail	Diagnostic: Supply Airflow Sensor Fail	004 - Information	Always
BI 312	Diagnostic: Gas Heat Supply Airflow Limit Trip	Diagnostic: Gas Heat Supply Airflow Limit Trip	004 - Information	Always

**Table 11. All object types sorted by object name (Refer to previous tables for detailed descriptions of objects)**

Object Identifier	Object Name	Description	When Exists
BI 165	Alarm Relay Output Status	Indicates the state of the alarm relay on the unit	Always
AI 95	BCI2-R Major Version	Major software version number of the BCI2-R module	Always
AI 96	BCI2-R Minor Version	Minor software version number of the BCI2-R module	Always



## Object Data Points and Diagnostic Data Points

**Table 11. All object types sorted by object name (Refer to previous tables for detailed descriptions of objects) (continued)**

Object Identifier	Object Name	Description	When Exists
AI 80	Cabinet Style	Describes the different cabinet types: 6 = Voyager/Precedent/Odyssey, 22 = Voyager Commercial	Always
BI 2	Compressor Lockout Status	One or more compressors are locked out with no diagnostic	Always
AO 19	Cool Capacity Enable Setpoint BAS	BAS supplied cooling demand limit capacity setpoint value	Always
BO 6	Cool Lockout Command	Command the unit to prevent cooling operation	Always
MI 25	Cool Output 1	Indicates the commanded state of cooling output 1	Always
MI 26	Cool Output 2	Indicates the commanded state of cooling output 2	Always
AI 81	Cool Type	Different cooling types: 7 = 1-Stage DX, 8 = 2-Stage DX, 9 = 3-Stage DX	Always
AI 1	Cooling Capacity Status	Indicates the unit cooling capacity being utilized	Always
MI 17	Cooling Reset Type Status	Indicates the type of cooling reset	With Multi-zone VAV and RTAM installed or Single-zone VAV
MI 22	Cooling Setpoint Source	Indicates the source of the space cooling setpoint	Always
BO 21	Daytime Warmup Enable Command	Command the unit daytime warmup operation	Always
AO 43	Daytime Warmup Initiate Temperature Setpoint BAS	BAS supplied daytime warmup Initiate temperature setpoint	RTAM is present and heat is present
AO 5	Daytime Warmup Terminate Temperature Setpoint BAS	BAS supplied daytime warmup terminate temperature setpoint	With RTAM and heat installed
AI 79	Dehumidification Capacity Status	Indicates the unit dehumidification capacity being utilized	With RTDM installed
BO 15	Dehumidification Enable Command	Command the operating state of the dehumidification system	With RTDM installed
AI 58	Dehumidification High Limit Setpoint	Humidity setpoint value that starts dehumidification control	With RTDM installed
AO 6	Discharge Air Cooling Setpoint BAS	BAS supplied discharge air temperature cooling setpoint value	When configured for Multi-zone VAV or Single Zone VAV
AO 7	Discharge Air Heating Setpoint BAS	BAS supplied discharge air temperature heating setpoint value	When configured for Multi-zone VAV, Single zone VAV, or with modulating heat
AI 61	Discharge Air Reheat Setpoint Active	Indicates the active supply air reheat temperature setpoint	With RTDM installed
AO 23	Discharge Air Reheat Setpoint BAS	BAS supplied discharge air reheat setpoint value	With RTDM installed
AI 24	Discharge Air Temperature Active	The discharge air temperature currently used for unit control	With RTOM installed
AI 52	Discharge Air Temperature Setpoint Active	Discharge air temperature setpoint value being used for unit control	When configured for Multi-zone VAV or Single zone VAV
AI 28	Duct Static Pressure Active	Duct static air pressure value currently being used for unit control	With RTAM installed
AI 48	Duct Static Pressure Setpoint Active	Duct static pressure setpoint value being used for unit control	With Multi-zone VAV and RTAM installed or Single-zone VAV

## Object Data Points and Diagnostic Data Points

**Table 11. All object types sorted by object name (Refer to previous tables for detailed descriptions of objects) (continued)**

Object Identifier	Object Name	Description	When Exists
AO 8	Duct Static Pressure Setpoint BAS	BAS supplied duct static air pressure setpoint value	With RTAM installed
MO 1	Economizer Airside Enable BAS	Command the state of the airside economizer system	With RTEM installed
BI 22	Economizer Airside Enable Status	Indicates the status of the airside economizer system	With RTEM installed
BO 7	Economizer Minimum Position Enable Command	Command the unit to the minimum position operation	With RTEM installed
AO 1	Economizer Minimum Position Setpoint BAS	BAS supplied economizer position minimum setpoint value	With RTEM installed
AI 86	Economizer Minimum Position Setpoint Local	Indicates the local economizer minimum position setpoint	With RTEM installed
MI 44	Economizer System Status	Indicates the operating state of the waterside economizer system	Always
AO 42	Economizing Enthalpy Enable Setpoint	Enthalpy Setpoint below which economizing can be used	With RTEM installed
AO 41	Economizing Temperature Enable Setpoint	Temperature Setpoint below which economizing can be used	With RTEM installed
MO 2	Emergency Override Command	Command the unit into an emergency mode of operation	Always
AI 9	Exhaust Damper Position Status	Indicates the unit exhaust damper position	Always
AI 71	Exhaust Enable Damper Position Setpoint Status	Exhaust air damper minimum position to enable exhaust sequence	With RTEM installed
MI 39	Exhaust Fan Proving Status	Indicates if the unit exhaust fan is off or on.	With RTOM installed (Only activates with RTEM installed)
AI 8	Exhaust Fan Speed Command	Indicates the unit commanded exhaust fan speed.	With RTEM installed
MI 38	Exhaust Fan Status	Indicates the commanded state of the exhaust fan.	With RTEM installed
AO 33	Exhaust or Return Fan Configuration	Sets the equipment exhaust or return fan type.	Always
AI 90	Exhaust or Return Fan Type	Describes the different exhaust or return fan types: 1 = None 2 = 1-Speed Exhaust Fan 7 = 1-Speed Exhaust Fan with Modulating Exhaust Damper	Always
AI 6	Filter Runtime Hours	Indicates the number of hours air has flowed through the filter.	Always
AV 1	Filter Runtime Hours Setpoint	The setpoint value used by the filter run hours calculation.	Always
BO 13	Filter Timer Reset	Command the unit to reset the accumulated filter run hours.	Always
AO 20	Heat Capacity Enable Setpoint BAS	BAS supplied heating demand limit capacity setpoint value.	With all heat types
MO 8	Heat Cool Mode Request BAS	Command the unit to a specific application mode.	Always
BO 5	Heat Lockout Command	Command the unit to prevent heating operation.	Always
MI 29	Heat Output 1	Indicates the commanded state of heating output 1.	Always
MI 30	Heat Output 2	Indicates the commanded state of heating output 2.	Always
MI 31	Heat Output 3	Indicates the commanded state of heating output 3.	Always
MI 32	Heat Output 4	Indicates the commanded state of heating output 4.	Always



## Object Data Points and Diagnostic Data Points

**Table 11. All object types sorted by object name (Refer to previous tables for detailed descriptions of objects) (continued)**

Object Identifier	Object Name	Description	When Exists
AI 2	Heat Primary Capacity Status	Indicates the unit primary heating capacity being utilized.	With modulating heat
AI 3	Heat Secondary Capacity Status	Indicates the unit secondary heating capacity being utilized.	With RTDM installed
MI 23	Heating Setpoint Source	Indicates the source of the space heating setpoint.	Always
BO 19	Lead-Lag Enable Command	Command the unit compressor startup order	Always
AI 25	Mixed Air Temperature	The mixed air temperature value from a unit-mounted sensor.	Always
BO 20	Morning Warmup Enable Command	Command the unit morning warmup operation	Always
AO 4	Morning Warmup Setpoint BAS	BAS supplied temperature setpoint used in morning warmup mode.	With RTAM and heat installed
AI 54	Morning Warmup Temperature Setpoint Active	The air temperature setpoint used during morning warmup mode.	When RTAM installed and heat installed
MO 7	Occupancy Request	Command the unit into an occupancy mode.	Always
MI 20	Occupancy Status	Indicates the current occupancy mode of the unit.	Always
AO 29	Occupied Offset	Offset used to calculate setpoints in occupied mode.	Always
AI 11	Outdoor Air Damper Position Status	Indicates the unit outdoor air damper position.	Always
AI 34	Outdoor Air Flow Active	Outdoor airflow utilized by the unit.	With RTVM version 3 or greater installed and RTRM firmware 9 or greater installed
AI 20	Outdoor Air Humidity Active	The outdoor air humidity value used for unit control.	With RTEM installed
AO 15	Outdoor Air Humidity BAS	BAS supplied outdoor air humidity sensor value.	Always
AI 57	Outdoor Air Minimum Flow Setpoint Active	The minimum outdoor airflow setpoint being utilized by the unit.	With RTVM version 3 or greater installed and RTRM firmware 9 or greater installed
AO 16	Outdoor Air Minimum Flow Setpoint BAS	BAS supplied minimum outdoor airflow setpoint.	With RTVM version 3 or greater installed and RTRM firmware 9 or greater installed
AI 18	Outdoor Air Temperature Active	The outdoor air temperature currently used for unit control.	With RTEM installed
AO 14	Outdoor Air Temperature BAS	BAS supplied outdoor air temperature sensor value.	Always
AO 46	Outdoor Air Temperature Heating Lockout Low Limit	Temperature at which Mechanical Heating will be locked out on a Heat Pump	Configured as a Heat Pump
MI 43	Outdoor Damper Status	Indicates the operating state of the outdoor damper.	Always
AO 34	Power Exhaust Enable Setpoint BAS	BAS supplied power exhaust enabled setpoint value.	With RTEM installed
AI 82	Preheat Type	Describes the different heating types: 129 = None 19 = 1-Stage DX 20 = 2-Stage DX 130 = Modulating Hot Water 134 = Modulating Electric 135 = 1-Stage Electric 136 = 2-Stage Electric 140 = 1-Stage Gas 141 = 2-Stage Gas 142 = Modulating Gas	Always

## Object Data Points and Diagnostic Data Points

**Table 11. All object types sorted by object name (Refer to previous tables for detailed descriptions of objects) (continued)**

Object Identifier	Object Name	Description	When Exists
MI 35	Primary Filter Status	Indicates the primary filter media state	Always
AI 5	Reheat Capacity Status	Indicates the unit reheat heating capacity being utilized	Dehumidification/ Reheat Configuration
AI 83	Reheat Type	Describes the different reheat types: 129 = None 17 = Hot Gas 19 = 1-Stage DX 20 = 2-Stage DX 130 = Modulating Hot Water 134 = Modulating Electric 135 = 1-Stage Electric 136 = 2-Stage Electric 140 = 1-Stage Gas 141 = 2-Stage Gas 142 = Modulating Gas	Always
BO 14	Reset Diagnostic	Command the unit to reset and clear diagnostics	Always
AI 26	Return Air Temperature	The return air temperature value from a unit-mounted sensor	With RTEM installed
AI 97	RTAM Major Version	Major software version number of the RTAM module	With RTAM installed
AI 98	RTAM Minor Version	Minor software version number of the RTAM module	With RTAM installed
AI 105	VSM Major Version	Major software version number of the VSM module	With VSM installed and RTRM version 15 or higher installed
AI 106	VSM Minor Version	Minor software version number of the VSM module	With VSM installed and RTRM version 15 or higher installed
AI 101	RTDM Major Version	Major software version number of the RTDM module	With RTDM installed and RTRM version 9 or higher installed
AI 102	RTDM Minor Version	Minor software version number of the RTDM module	With RTDM installed and RTRM version 9 or higher installed
AI 99	RTEM Major Version	Major software version number of the RTEM module	With RTEM installed
AI 100	RTEM Minor Version	Minor software version number of the RTEM module	With RTEM installed
AI 93	RTOM Major Version	Major software version number of the RTOM module	With RTOM installed
AI 94	RTOM Minor Version	Minor software version number of the RTOM module	With RTOM installed
AI 91	RTRM Major Version	Major software version number of the RTRM module	Always
AI 92	RTRM Minor Version	Minor software version number of the RTRM module	Always
AI 103	RTVM Major Version	Major software version number of the RTVM module	With RTVM installed and RTRM version 9 or higher installed
AI 104	RTVM Minor Version	Minor software version number of the RTVM module	With RTVM installed and RTRM version 9 or higher installed
BO 17	Service Test Command	Command the unit to step through service test	Always
BI 11	Service Test Mode Status	Indicates if the unit is in service test mode.	Always
MI 45	Service Test Status	Indicates the current Service Test state	Always
AI 32	Space CO <sub>2</sub> Concentration Active	Space CO <sub>2</sub> concentration being used for unit control	With RTEM installed



## Object Data Points and Diagnostic Data Points

**Table 11. All object types sorted by object name (Refer to previous tables for detailed descriptions of objects) (continued)**

Object Identifier	Object Name	Description	When Exists
AO 18	Space CO <sub>2</sub> Concentration BAS	BAS supplied space CO <sub>2</sub> sensor value	Always
AO 21	Space Dehumidification Setpoint BAS	BAS supplied space dehumidification setpoint value	With RTDM installed
AI 16	Space Humidity Active	The space humidity value from a unit-mounted control	With RTOM installed
AO 25	Space Humidity BAS	BAS supplied space humidity sensor value	With RTDM installed
AI 31	Space Static Air Pressure Active	Space static air pressure value being used for unit control	When configured for Modulating Powered Exhaust and version 9 or greater RTRM firmware installed
AO 10	Space Static Pressure BAS	BAS supplied space static air pressure sensor value	With Modulating Power Exhaust
AI 107	Space Static Pressure Setpoint Active	Space pressure setpoint currently used for unit control	Always
AO 9	Space Static Pressure Setpoint BAS	BAS supplied space static air pressure setpoint value	With Modulating Power Exhaust and RTRM version 9 or higher installed
AI 15	Space Temperature Active	The space temperature currently used for unit control	Always
AO 11	Space Temperature BAS	BAS supplied space air temperature sensor value	Always
AI 74	Space Temperature Cooling Setpoint Input	Cooling temperature setpoint from space sensor module	Always
AI 75	Space Temperature Heating Setpoint Input	Heating temperature setpoint from space sensor module	Always
AI 87	Space Temperature Local	The space air temperature measured by a unit-mounted sensor	Always
AI 50	Space Temperature Setpoint Active	Space temperature setpoint value being used for unit control	Always
AO 2	Space Temperature Setpoint BAS	Base value to calculate setpoints in occupied and standby modes	Always
AI 78	Space Temperature Setpoint Local	The local space temperature setpoint	Always
AO 30	Standby Offset	Offset value used to calculate setpoints in standby mode	Always
BO 18	Supply Air Tempering Enable Command	Command the unit supply air tempering operation	With all heat types
BI 292	Supply Air Tempering Status	Indicates the status of the supply air tempering function	Always
BO 8	Supply Fan Configuration Command	Command the unit supply fan to cycling or continuous operation	Always
BI 15	Supply Fan Configuration Status	Indicates the supply fan configuration	Constant Volume
AO 44	Supply Fan Minimum Speed BAS	BAS supplied minimum fan speed	Supply fan is not single speed
AO 45	Supply Fan Maximum Speed BAS	BAS supplied maximum fan speed	Supply fan is not single speed
MI 37	Supply Fan Proving Status	Indicates the current state of the supply fan	Always
AI 7	Supply Fan Speed Command	Indicates the unit commanded supply fan speed	Always
MI 41	Supply Fan Status	Indicates the state of the supply fan	Always

## Object Data Points and Diagnostic Data Points

**Table 11. All object types sorted by object name (Refer to previous tables for detailed descriptions of objects) (continued)**

Object Identifier	Object Name	Description	When Exists
AI 89	Supply Fan Type	Describes the different supply fan types: 2 = 1-Speed Supply Fan 3 = 2-Speed Supply Fan 4 = 3-Speed Supply Fan 7 = 4-Speed Supply Fan 8 = 5-Speed Supply Fan 5 = Modulating Inlet Guide Vanes Supply Fan 6 = Variable Speed Supply Fan 35 = SZVAV 2-Speed Supply Fan 36 = SZVAV 3-Speed Supply Fan 39 = SZVAV 4-Speed Supply Fan 40 = SZVAV 5-Speed Supply Fan 38 = SZVAV Variable Speed Supply Fan	Always
BO 1	System Control Command	Command the unit to standalone- or BAS-controlled operation	Always
BI 1	System Control Status	Indicates the control system currently in command of the unit	Always
MI 24	Timed Override Status	Timed override request or cancel from zone sensor	Always
AI 108	Tracer TD5 Major Version	Major Software version number of the TD5 module	With TD5 installed and RTRM version 15 or higher installed
AI 109	Tracer TD5 Minor Version	Minor Software version number of the TD5 module	With TD5 installed and RTRM version 15 or higher installed
AI 88	Unit Energy Demand	Indicates the current heat/cool energy demand of the unit	Always
MI 21	Unit Stop Source	Source of the stop command that turned off the equipment	Always
AO 31	Unoccupied Cooling Setpoint	Cooling temperature setpoint used for control in unoccupied mode	Always
AO 32	Unoccupied Heating Setpoint	Heating temperature setpoint used for control in unoccupied mode	Always
BI 9	VAV Box Command	Indicates whether VAV boxes should be in control or wide open	Multi-zone VAV and RTAM installed
AI 105	VSM Major Version	Major software version number of the VSM module	With VSM installed and RTRM version 15 or higher installed
AI 106	VSM Minor Version	Minor software version number of the VSM module	With VSM installed and RTRM version 15 or higher installed

**Table 12. Notification classes**

Notification Class	Severity
Class 001	Critical
Class 002	Service Required
Class 003	Advisory
Class 004	Information

## Object Data Points and Diagnostic Data Points

**Table 13. Diagnostic objects sorted by object name**

<b>Object Identifier Binary Input</b>	<b>Object Name</b>	<b>Description</b>	<b>Notification Class</b>	<b>When Exists</b>
BI 59	Diagnostic: Auto - SA High Press Limit	Diagnostic: Auto - SA High Press Limit	002 – Service Required	Always
BI 308	Diagnostic: Air Damper Not Modulating	Diagnostic: Damper NOT Modulating	004 - Information	With RTRM 16 or higher installed
BI 271	Diagnostic: CO2 Low Limit Setpoint Fault	Diagnostic: CO2 Low Limit Setpoint Fault	004 – Information	With RTEM installed
BI 83	Diagnostic: CO2 Sensor Failure	Diagnostic: CO2 Sensor Failure	002 – Service Required	With RTEM installed
BI 257	Diagnostic: CO2 Setpoint Failure	Diagnostic: CO2 Setpoint Failure	004 – Information	With RTEM installed
BI 45	Diagnostic: Coil Temp Sensor 1 Fail	Diagnostic: Coil Temp Sensor 1 Fail 1	002 – Service Required	Always
BI 46	Diagnostic: Coil Temp Sensor 2 Fail	Diagnostic: Coil Temp Sensor 2 Fail	002 – Service Required	Always
BI 269	Diagnostic: Comp 1 Disable Input HPC	Diagnostic: Comp 1 Disable Input HPC	004 – Information	Always
BI 244	Diagnostic: Comp 1 Disable Input LPC	Diagnostic: Comp 1 Disable Input LPC	004 – Information	Always
BI 270	Diagnostic: Comp 2 Disable Input HPC	Diagnostic: Comp 2 Disable Input HPC	004 – Information	Always
BI 245	Diagnostic: Comp 2 Disable Input LPC	Diagnostic: Comp 2 Disable Input LPC	004 – Information	Always
BI 302	Diagnostic: Comp 3 Disable Input LPC	Diagnostic: Compressor 3 Disable Input LPC	004 - Information	With Compressor 3 or VSPD compressor and RTRM 16 or higher installed
BI 47	Diagnostic: Compressor 1 HPC Lockout	Diagnostic: Compressor 1 HPC Lockout	001 – Critical	Always
BI 43	Diagnostic: Compressor 1 LPC Lockout	Diagnostic: Compressor 1 LPC Lockout	001 – Critical	Always
BI 48	Diagnostic: Compressor 2 HPC Lockout	Diagnostic: Compressor 2 HPC Lockout	001 – Critical	Always
BI 44	Diagnostic: Compressor 2 LPC Lockout	Diagnostic: Compressor 2 LPC Lockout	001 – Critical	Always
BI 301	Diagnostic: Compressor 3 HPC Disable	Diagnostic: Compressor 3 HPC Disable	004 - Information	With Compressor 3 or VSPD compressor and RTRM 16 or higher installed
BI 299	Diagnostic: Compressor 3 HPC Lockout Status	Diagnostic: Compressor 3 HPC Lockout Status	001 - Critical	With Compressor 3 or VSPD compressor and RTRM 16 or higher installed

## Object Data Points and Diagnostic Data Points

**Table 13. Diagnostic objects sorted by object name (continued)**

Object Identifier Binary Input	Object Name	Description	Notification Class	When Exists
BI 300	Diagnostic: Compressor 3 LPC Lockout Status	Diagnostic: Compressor 3 LPC Lockout Status	001 - Critical	With Compressor 3 or VSPD compressor and RTRM 16 or higher installed
BI 303	Diagnostic: Compressor Drive Fault	Diagnostic: Compressor Drive Fault	001 - Critical	With VSPD compressor and RTRM 16 or higher installed
BI 304	Diagnostic: Compressor Drive Lockout	Diagnostic: Compressor Drive Lockout	001 - Critical	With Compressor 3 and RTRM 16 or higher installed
BI 297	Diagnostic: DCV Min Position at Minimum Fan Speed	Diagnostic: DCV Min Position at Minimum Fan Speed	004 - Information	With RTVM installed
BI 293	Diagnostic: DCV Min Position Setpoint Fail	Diagnostic: DCV Min Position Setpoint Fail	004 - Information	With RTEM installed
BI 252	Diagnostic: Default Defrost Flag	Diagnostic: Default Defrost Flag	004 - Information	With Heat Pump installed
BI 287	Diagnostic: Defrost Default Mode Ckt 1	Diagnostic: Defrost Default Mode Ckt 1	004 - Information	With Heat Pump installed
BI 283	Diagnostic: Defrost Default Mode Ckt 2	Diagnostic: Defrost Default Mode Ckt 2	004 - Information	With Heat Pump installed
BI 125	Diagnostic: Dehumid Setpoint Failure	Diagnostic: Dehumid Setpoint Failure	002 - Service Required	With RTOM installed
BI 248	Diagnostic: Demand Defrost Fault A	Diagnostic: Demand Defrost Fault A	004 - Information	With Heat Pump installed
BI 284	Diagnostic: Demand Defrost Fault A Ckt 1	Diagnostic: Demand Defrost Fault A Ckt 1	004 - Information	With Heat Pump installed
BI 280	Diagnostic: Demand Defrost Fault A Ckt 2	Diagnostic: Demand Defrost Fault A Ckt 2	004 - Information	Always
BI 249	Diagnostic: Demand Defrost Fault B	Diagnostic: Demand Defrost Fault B	004 - Information	With Heat Pump installed
BI 285	Diagnostic: Demand Defrost Fault B Ckt 1	Diagnostic: Demand Defrost Fault B Ckt 1	004 - Information	With Heat Pump installed
BI 281	Diagnostic: Demand Defrost Fault B Ckt 2	Diagnostic: Demand Defrost Fault B Ckt 2	004 - Information	With Heat Pump installed
BI 250	Diagnostic: Demand Defrost Fault C	Diagnostic: Demand Defrost Fault C	004 - Information	With Heat Pump installed
BI 286	Diagnostic: Demand Defrost Fault C Ckt 1	Diagnostic: Demand Defrost Fault C Ckt 1	004 - Information	With Heat Pump installed
BI 282	Diagnostic: Demand Defrost Fault C Ckt 2	Diagnostic: Demand Defrost Fault C Ckt 2	004 - Information	With Heat Pump installed
BI 251	Diagnostic: Demand Defrost Fault D	Diagnostic: Demand Defrost Fault D	004 - Information	With Heat Pump installed
BI 298	Diagnostic: Design Min Position at Midpoint Fan Speed Fail	Diagnostic: Design Min Position at Midpoint Fan Speed Fail	004 - Information	With RTVM installed



## Object Data Points and Diagnostic Data Points

**Table 13. Diagnostic objects sorted by object name (continued)**

<b>Object Identifier Binary Input</b>	<b>Object Name</b>	<b>Description</b>	<b>Notification Class</b>	<b>When Exists</b>
BI 296	Diagnostic: Design Min Position at Minimum Fan Speed Fail	Diagnostic: Design Min Position at Minimum Fan Speed Fail	004 – Information	With RTVM installed
BI 294	Diagnostic: Design Min Position Setpoint Fail	Diagnostic: Design Min Position Setpoint Fail	004 – Information	With RTEM installed
BI 76	Diagnostic: Dirty Filter	Diagnostic: Dirty Filter	003 – Advisory	Always
BI 289	Diagnostic: Discharge Air Heat Setpoint Failure	Diagnostic: Discharge Air Heat Setpoint Failure	004 – Information	With RTOM installed
BI 264	Diagnostic: Economizer Actuator Fault	Diagnostic: Economizer Actuator Fault	004 – Information	Always
BI 107	Diagnostic: Entering Evap Temp Sensor Fail	Diagnostic: Entering Evap Temp Sensor Fail	002 – Service Required	Always
BI 295	Diagnostic: Enthalpy Setpoint Fail	Diagnostic: Enthalpy Setpoint Fail	004 – Information	Always
BI 40	Diagnostic: Exhaust Fan Proving Failure	Diagnostic: Exhaust Fan Proving Failure	001 – Critical	With RTEM installed
BI 288	Diagnostic: Exhaust Fan Setpoint Failure	Diagnostic: Exhaust Fan Setpoint Failure	004 – Information	With RTOM installed
BI 151	Diagnostic: External Auto-Stop	Diagnostic: External Auto-Stop	004 – Information	With RTOM installed
BI 307	Diagnostic: Excessive Air	Diagnostic: Excessive Air	004 - Information	With RTRM 16 or higher installed
BI 39	Diagnostic: Fan Failure	Diagnostic: Fan Failure	001 – Critical	With RTEM installed
BI 259	Diagnostic: Flame Rollout Switch Open	Diagnostic: Flame Rollout Switch Open	004 – Information	With Gas Heat installed
BI 262	Diagnostic: Flame Sensed with Gas Valve Off	Diagnostic: Flame Sensed with Gas Valve Off	004 – Information	With Gas Heat installed
BI 256	Diagnostic: Freezestat Tripped	Diagnostic: Freezestat Tripped	004 – Information	With RTOM installed
BI 247	Diagnostic: FroStat Trip	Diagnostic: FroStat Trip	004 – Information	With RTOM installed
BI 263	Diagnostic: Gas Heat Module Failure	Diagnostic: Gas Heat Module Failure	004 – Information	Always
BI 312	Diagnostic: Gas Heat Supply Airflow Limit Trip	Diagnostic: Gas Heat Supply Airflow Limit Trip	004 - Information	Always
BI 51	Diagnostic: Heat Failure	Diagnostic: Heat Failure	003 – Advisory	Always
BI 258	Diagnostic: Heating High Temp Limit Open	Diagnostic: Heating High Temp Limit Open	004 – Information	With Gas Heat installed
BI 290	Diagnostic: IGN1 Communications Timed out	Diagnostic: IGN1 Communications Timed out	004 – Information	With Gas Heat installed
BI 291	Diagnostic: IGN2 Communications Timed out	Diagnostic: IGN2 Communications Timed out	004 – Information	With Gas Heat installed
BI 260	Diagnostic: Inducer Proving Switch Fail	Diagnostic: Inducer Proving Switch Fail	004 – Information	With Gas Heat installed
BI 34	Diagnostic: Local Cool Setpoint Fail	Diagnostic: Local Cool Setpoint Fail	002 – Service Required	Always
BI 38	Diagnostic: Local Emergency Stop Initiated	Diagnostic: Local Emergency Stop Initiated	001 – Critical	Always

## Object Data Points and Diagnostic Data Points

**Table 13. Diagnostic objects sorted by object name (continued)**

<b>Object Identifier Binary Input</b>	<b>Object Name</b>	<b>Description</b>	<b>Notification Class</b>	<b>When Exists</b>
BI 35	Diagnostic: Local Zone Heat Setpoint Fail	Diagnostic: Local Zone Heat Setpoint Fail	002 – Service Required	Always
BI 147	Diagnostic: Maintenance Required	Diagnostic: Maintenance Required	002 – Service Required	Always
BI 242	Diagnostic: Min OA Flow Setpoint Fail	Diagnostic: Min OA Flow Setpoint Fail	002 – Service Required	With RTVM installed
BI 310	Diagnostic: Mixed Air Temp Low Limit Cycle Active	Diagnostic: Mixed Air Temp Low Limit Cycle Active	004 - Information	Always
BI 95	Diagnostic: Mixed Air Temp Sensor Failure	Diagnostic: Mixed Air Temp Sensor Failure	002 – Service Required	With RTEM installed
BI 279	Diagnostic: Mod Dehumid Config Error	Diagnostic: Mod Dehumid Config Error	004 – Information	Always
BI 239	Diagnostic: Morning Warmup Setpoint Fail	Diagnostic: Morning Warmup Setpoint Fail	002 – Service Required	Always
BI 261	Diagnostic: No Flame Sensed on heat call	Diagnostic: No Flame Sensed on heat call	004 – Information	With Gas Heat installed
BI 37	Diagnostic: OA Humidity Sensor Failure	Diagnostic: OA Humidity Sensor Failure	002 – Service Required	With RTEM installed
BI 32	Diagnostic: OA Temperature Sensor Fail	Diagnostic: OA Temperature Sensor Fail	002 – Service Required	Always
BI 58	Diagnostic: Return Air Humidity Sensor Fail	Diagnostic: Return Air Humidity Sensor Fail	002 – Service Required	With RTEM installed
BI 57	Diagnostic: Return Air Temp Sensor Fail	Diagnostic: Return Air Temp Sensor Fail	002 – Service Required	With RTEM installed
BI 274	Diagnostic: RTAM Comm Fail	Diagnostic: RTAM Comm Fail	004 – Information	With RTAM installed
BI 276	Diagnostic: VSM Comm Fail	Diagnostic: VSM Communication Fail	004 – Information	With VSM installed
BI 277	Diagnostic: RTDM Comm Fail	Diagnostic: RTDM Comm Fail	004 – Information	With RTDM installed
BI 273	Diagnostic: RTEM Comm Fail	Diagnostic: RTEM Comm Fail	004 – Information	With RTEM installed
BI 29	Diagnostic: RTM Zone Temp Sensor Failure	Diagnostic: Zone Temp Sensor Failure	002 – Service Required	
BI 272	Diagnostic: RTOM Comm Fail	Diagnostic: RTOM Comm Fail	004 – Information	With RTOM installed
BI 275	Diagnostic: RTVM Comm Fail	Diagnostic: RTVM Comm Fail	004 – Information	With RTVM installed
BI 267	Diagnostic: SA Pressure Dead Band Failure	Diagnostic: SA Pressure Dead Band Failure	004 – Information	With RTAM installed
BI 268	Diagnostic: SA Pressure PWM Fault	Diagnostic: SA Pressure PWM Fault	004 – Information	Always
BI 54	Diagnostic: SA Pressure Setpoint Failure	Diagnostic: SA Pressure Setpoint Failure	002 – Service Required	Always
BI 123	Diagnostic: SA Reheat Setpoint Failure	Diagnostic: SA Reheat Setpoint Failure	002 – Service Required	Always
BI 265	Diagnostic: SA Reset Amount Failure	Diagnostic: SA Reset Amount Failure	004 – Information	With RTOM installed



## Object Data Points and Diagnostic Data Points

**Table 13. Diagnostic objects sorted by object name (continued)**

<b>Object Identifier Binary Input</b>	<b>Object Name</b>	<b>Description</b>	<b>Notification Class</b>	<b>When Exists</b>
BI 266	Diagnostic: SA Reset Setpoint Failure	Diagnostic: SA Reset Setpoint Failure	004 – Information	With RTAM installed
BI 74	Diagnostic: SA Temp Cool Setpoint Fail	Diagnostic: SA Temp Cool Setpoint Fail	002 – Service Required	Always
BI 75	Diagnostic: SA Temp Heat Setpoint Fail	Diagnostic: SA Temp Heat Setpoint Fail	002 – Service Required	Always
BI 246	Diagnostic: Smoke Detector	Diagnostic: Smoke Detector	004 – Information	With RTOM installed
BI 106	Diagnostic: Space Humidity Sensor Fail	Diagnostic: Space Humidity Sensor Fail	002 – Service Required	With RTEM installed
BI 278	Diagnostic: Space Press Deadband Fail	Diagnostic: Space Press Deadband Fail	004 – Information	Always
BI 56	Diagnostic: Space Pressure Sensor Fail	Diagnostic: Space Pressure Sensor Fail	002 – Service Required	Always
BI 55	Diagnostic: Space Pressure Setpoint Fail	Diagnostic: Space Pressure Setpoint Fail	002 – Service Required	Always
BI 311	Diagnostic: Supply Airflow Sensor Fail	Diagnostic: Supply Airflow Sensor Fail	004 - Information	Always
BI 36	Diagnostic: Supply Air Press Sensor Fail	Diagnostic: Supply Air Press Sensor Fail	002 – Service Required	Always
BI 30	Diagnostic: Supply Air Temp Sensor Fail	Diagnostic: Supply Air Temp Sensor Fail	002 – Service Required	Always
BI 309	Diagnostic: TD5 Comm Fail	Diagnostic: Tracer TD5 Communication Fail	004 - Information	With TD5 installed and RTRM 15 or higher installed
BI 148	Diagnostic: Unit Communications Failure	Diagnostic: Unit Communications Failure	002 – Service Required	Always
BI 305	Diagnostic: Unit Economizing When It Should Not	Diagnostic: Unit Economizing When It Should Not	004 - Information	With RTEM 3 or higher installed and RTRM 16 or higher installed
BI 306	Diagnostic: Unit Not Economizing When It Should	Diagnostic: Unit Not Economizing When It Should	004 - Information	With RTEM 3 or higher installed and RTRM 16 or higher installed
BI 86	Diagnostic: Velocity Press Sensor Fail	Diagnostic: Velocity Press Sensor Fail	002 – Service Required	With RTVM version 3 or greater installed
BI 253	Diagnostic: Vent Override - Exhaust	Diagnostic: Vent Override - Exhaust	004 – Information	With RTOM installed
BI 255	Diagnostic: Vent Override - Pressurize	Diagnostic: Vent Override - Pressurize	004 – Information	With RTOM installed
BI 254	Diagnostic: Vent Override - Purge	Diagnostic: Vent Override - Purge	004 – Information	With RTOM installed



## Additional Resources

- [Tracer® TU Service tool Getting Started Guide \(TTU-SVN02\\*-EN\)](#)
- [Tracer TU Help Online](#)
- [Tracer TU Service Tool for Water-cooled CenTraVac Chillers with Tracer AdapiView Control Programming Guide \(CTV-SVP02\\*-EN\)](#)



Notes

---



Trane - by Trane Technologies (NYSE: TT), a global innovator - creates comfortable, energy efficient indoor environments for commercial and residential applications. For more information, please visit [trane.com](http://trane.com) or [tranetechnologies.com](http://tranetechnologies.com).

Trane has a policy of continuous product and product data improvements and reserves the right to change design and specifications without notice. We are committed to using environmentally conscious print practices.