



Integration Guide

# Trane® Mitsubishi Electric VRF Integration License

for the Tracer® SC+ System Controller

## **▲ SAFETY WARNING**

Only qualified personnel should install and service the equipment. The installation, starting up, and servicing of heating, ventilating, and air-conditioning equipment can be hazardous and requires specific knowledge and training. Improperly installed, adjusted or altered equipment by an unqualified person could result in death or serious injury. When working on the equipment, observe all precautions in the literature and on the tags, stickers, and labels that are attached to the equipment.

October 2025

**BAS-SVP044C-EN**

**TRANE**  
TECHNOLOGIES™



## Introduction

Read this manual thoroughly before operating or servicing this unit.

## Warnings, Cautions, and Notices

Safety advisories appear throughout this manual as required. Your personal safety and the proper operation of this machine depend upon the strict observance of these precautions.

The three types of advisories are defined as follows:



Indicates a potentially hazardous situation which, if not avoided, could result in death or serious injury.



Indicates a potentially hazardous situation which, if not avoided, could result in minor or moderate injury. It could also be used to alert against unsafe practices.

**NOTICE**

Indicates a situation that could result in equipment or property-damage only accidents.

## Important Environmental Concerns

Scientific research has shown that certain man-made chemicals can affect the earth's naturally occurring stratospheric ozone layer when released to the atmosphere. In particular, several of the identified chemicals that may affect the ozone layer are refrigerants that contain Chlorine, Fluorine and Carbon (CFCs) and those containing Hydrogen, Chlorine, Fluorine and Carbon (HCFCs). Not all refrigerants containing these compounds have the same potential impact to the environment. Trane advocates the responsible handling of all refrigerants.

## Important Responsible Refrigerant Practices

Trane believes that responsible refrigerant practices are important to the environment, our customers, and the air conditioning industry. All technicians who handle refrigerants must be certified according to local rules. For the USA, the Federal Clean Air Act (Section 608) sets forth the requirements for handling, reclaiming, recovering and recycling of certain refrigerants and the equipment that is used in these service procedures. In addition, some states or municipalities may have additional requirements that must also be adhered to for responsible management of refrigerants. Know the applicable laws and follow them.

### **⚠ WARNING**

#### **Proper Field Wiring and Grounding Required!**

Failure to follow code could result in death or serious injury.

**All field wiring MUST be performed by qualified personnel. Improperly installed and grounded field wiring poses FIRE and ELECTROCUTION hazards. To avoid these hazards, you MUST follow requirements for field wiring installation and grounding as described in NEC and your local/state/national electrical codes.**

## ⚠ WARNING

### Personal Protective Equipment (PPE) Required!

Failure to wear proper PPE for the job being undertaken could result in death or serious injury.

Technicians, in order to protect themselves from potential electrical, mechanical, and chemical hazards, **MUST** follow precautions in this manual and on the tags, stickers, and labels, as well as the instructions below:

- Before installing/servicing this unit, technicians **MUST** put on all PPE required for the work being undertaken (Examples; cut resistant gloves/sleeves, butyl gloves, safety glasses, hard hat/bump cap, fall protection, electrical PPE and arc flash clothing). **ALWAYS** refer to appropriate Safety Data Sheets (SDS) and OSHA guidelines for proper PPE.
- When working with or around hazardous chemicals, **ALWAYS** refer to the appropriate SDS and OSHA/GHS (Global Harmonized System of Classification and Labelling of Chemicals) guidelines for information on allowable personal exposure levels, proper respiratory protection and handling instructions.
- If there is a risk of energized electrical contact, arc, or flash, technicians **MUST** put on all PPE in accordance with OSHA, NFPA 70E, or other country-specific requirements for arc flash protection, **PRIOR** to servicing the unit. **NEVER PERFORM ANY SWITCHING, DISCONNECTING, OR VOLTAGE TESTING WITHOUT PROPER ELECTRICAL PPE AND ARC FLASH CLOTHING. ENSURE ELECTRICAL METERS AND EQUIPMENT ARE PROPERLY RATED FOR INTENDED VOLTAGE.**

## ⚠ WARNING

### Follow EHS Policies!

Failure to follow instructions below could result in death or serious injury.

- All Trane personnel must follow the company's Environmental, Health and Safety (EHS) policies when performing work such as hot work, electrical, fall protection, lockout/tagout, refrigerant handling, etc. Where local regulations are more stringent than these policies, those regulations supersede these policies.
- Non-Trane personnel should always follow local regulations.

## ⚠ WARNING

### Cancer and Reproductive Harm!

This product can expose you to chemicals including lead and bisphenol A (BPA), which are known to the State of California to cause cancer and birth defects or other reproductive harm. For more information go to [www.P65Warnings.ca.gov](http://www.P65Warnings.ca.gov).

## Copyright

This document and the information in it are the property of Trane, and may not be used or reproduced in whole or in part without written permission. Trane reserves the right to revise this publication at any time, and to make changes to its content without obligation to notify any person of such revision or change.

## Trademarks

All trademarks referenced in this document are the trademarks of their respective owners.

## Revision History

- Updated the list of supported controllers.
- Updated the Quick Start Task List.
- Updated the Enable Maintenance Data chapter.
- Updated the Discovering VRF Devices section.
- Updated Update IP Address of Centralized Controller chapter.
- Updated the Lossnay table.

- 
- Updates to user interface screens throughout the document.



# Table of Contents

- Overview ..... 7
- Quick Start Task List ..... 8
- Prepare the VRF System ..... 11
- Enable Maintenance Data ..... 15
- Identify Customer Network Security Needs ..... 18
- Discover and Install VRF Devices in Tracer® SC+ ..... 20
  - Discovering VRF Devices ..... 20
    - Auto-installed Devices ..... 22
  - Creating a VRF Template ..... 23
    - Best Practices when Creating New Equipment Templates ..... 24
  - Editing a VRF Equipment Template ..... 25
- Complete the VRF Integration ..... 27
  - Verify the VRF Data ..... 27
  - Graphics ..... 28
    - Creating a Custom Template ..... 28
    - Tracer® Graphics Editor (TGE) ..... 30
  - Setting Up Control Logic ..... 30
    - Unoccupied Temperature Control ..... 30
    - Trim/Respond Application ..... 32
  - Refresh Equipment ..... 32
  - Update Centralized Controller Settings ..... 33
    - Update Login Credentials ..... 33
    - Update IP Address ..... 34
  - Other Application Considerations ..... 35
    - DOAS (Dedicated Outdoor Air System) Control ..... 35
    - Tracer® Ensemble ..... 35
    - Tenant Services ..... 35
    - Tracer® TU TGE ..... 36
    - 10-inch Display ..... 36
    - BAS Operator App ..... 36
    - Occupancy App ..... 36
    - Air-Fi® Integration ..... 36
- Using the Trane/Mitsubishi Electric VRF License on an Existing Mitsubishi Electric VRF System ..... 37
  - No Existing BAS Integration ..... 37
  - Existing BACnet® Integration ..... 37
- Integrating to Third-Party BACnet® Systems ..... 38
- Troubleshooting ..... 39



## Table of Contents

---

Tools .....	39
Trane Enable Maintenance Data Tool .....	39
Maintenance Tool (M-Tool) for .NET .....	40
AE-200 Update Tool .....	40
AE-200 Initial Settings Tool .....	40
Diamond System Builder (DSB) .....	40
Integrated Centralized Control Web Interface (ICCW) .....	40
Appendix .....	42
Single, Dual, and Auto Setpoint(s) .....	42
VRF Model Names and Factory Templates .....	42
Point List .....	43
Communication Status .....	43
BAS and Arbitration Points .....	43
Indoor Unit (IDU) .....	44
Outdoor Unit (ODU) – Air Cooled .....	49
Branch Controller (BC) .....	53
Remote Controller .....	56
Lossnay .....	56
Heat Exchanger (HEX) .....	59



## Overview

This integration guide will discuss integrating a Trane Mitsubishi Electric VRF system with a Tracer® SC+ system controller using the Tracer SC+ VRF Integration license. Tracer SC+ uses Ethernet communications with a Centralized Controller (T/AE-200, T/AE-50, T/EW-50, AE-C400, and EW-C50) and discovers the configured VRF devices. Tracer SC+ automatically installs most VRF equipment. Other VRF equipment can be installed by using a Tracer SC+ template.

A Tracer SC+ VRF license (BMCF000AAA0BI00) must be purchased for each Tracer SC+ system controller that will be integrated with a Trane Mitsubishi Electric VRF system. Each installed VRF device will require a Tracer SC+ device license, with the exception of Smart ME remote controllers. Smart ME remote controllers are MNET-communicating remote controllers and do not require a Tracer® SC+ device license.

A Tracer SC+ can integrate up to 240 total devices (VRF and non-VRF combined). For example, a site has two (2) Centralized Controllers. Each Centralized Controller controls three (3) Outdoor Units, two (2) Branch Controllers, 30 Indoor units, and five (5) Smart ME remote controllers. This site would require 70 device licenses and a VRF Integration license.

This integration guide will not cover instruction for the Mitsubishi Electric BACnet® license, which is not required for this integration. The Trane VRF Integration license has significant advantages over the Mitsubishi Electric BACnet driver including:

- Additional Indoor Unit data.
- Support for Outdoor Unit, Branch Controller and other VRF equipment.
- Automated installation with standard graphics for most VRF equipment.
  - Uses standard keys for Trane applications and products.
- Integrates with Tracer Ensemble, Tenant services, and Trane Intelligent Services.
- Provides additional VRF data to third-party BACnet BAS systems.
- Supports local and BAS control in a “last source to control wins” manner.
- Lower cost than other BAS integration solutions.



# Quick Start Task List

The following is a quick start task list that outlines the high-level process of integrating the Trane Mitsubishi Electric VRF system into the Tracer® SC+ controller. Additional steps are provided in subsequent sections of in this guide.

**Important:** *Most integration issues are due to the VRF system NOT setup correctly! Please read the following carefully.*

## “Prepare the VRF System,” p. 11

- Review and verify the Centralized Controller requirements:
  - The Mitsubishi Electric VRF System must be installed and operating with a Centralized Controller (T/AE-200, T/AE-50, T/EW-50, AE-C400, and EW-C50).
  - The Centralized Controller must be running firmware version 7.8 or later.
- Most IDUs use dual setpoints (default and recommended). The Centralized Controller can be configured to force all IDUs to use single setpoint. Dual setpoints are recommended for integration to Tracer SC+.
- Group setup:
  - All Indoor Units (IDUs) must be a member of a group.
  - All IDUs that share the same sensor (wired or via MNET communications) must be in the same group.
  - The Smart ME remote controllers can optionally be a member of a group. If they are not a member of a group, Tracer® SC+ will not discover the Smart ME controllers.
- Configure and record the IP address of each Centralized Controller.
- The new generation of centralized controllers (AE-400, EW-C50) communicate using a secure HTTPS protocol and require authentication. Record the username and password from the Centralized Controller, as these credentials are necessary for discovering and installing devices connected to the new centralized controllers on the Tracer SC+.

**Note:** *Unless they have been changed, the default credentials for accessing the Centralized Controller panel or web interface can also be used for device discovery on the Tracer SC+.*

- Connect Port 1 of each Centralized Controller to the LAN or local switch and verify IP communications using ping or a similar utility.

## “Enable Maintenance Data,” p. 15

- Obtain the Trane Maintenance Data Tool from Trane Updater or the Controls Download page.
- Use your laptop to verify IP communication to the Centralized Controller by using ping or a similar utility.
- Connect your laptop to the same IP network as the Centralized Controller or directly connect your laptop to Port 1 of the Centralized Controller.
- Run the Trane software tool MaintenanceDataTool.exe
- Enter the IP address of the Centralized Controller.

A list of VRF devices that support or do not support maintenance data will be shown. Use this information to verify that the VRF devices shown match what was setup in the Centralized Controller before proceeding to the section.

## “Identify Customer Network Security Needs,” p. 18

Design and configure controllers for the appropriate network architecture based on customer security needs.

## “Discover and Install VRF Devices in Tracer® SC+,” p. 20

- Obtain the Tracer SC+ license with VRF integration and device licenses from the licensing server.
- Upload the Tracer SC+ license to Tracer SC+.
  - Only the Tracer SC+ integrating to the Centralized Controller requires a VRF license.
  - Each VRF device installed into Tracer SC+ requires a device license.
    - A Tracer SC+ supports a maximum of 240 devices.
    - Tracer SC+ must be running firmware version 5.4 or later.
    - Auto-installing the Smart ME remote controller does not require a device license.
- In Tracer® Synchrony, verify the Tracer® SC+ license information shows both MNet and VRF.

**Figure 1. Verify MNET and VRF on product license**



- Start the discovery process by selecting the **Trane VRF (XML/IP)** option and enter the IP address of the Centralized Controller. This process must be repeated separately for each Centralized Controller.

**Figure 2. Device discovery (Trane VRF (XML/IP))**

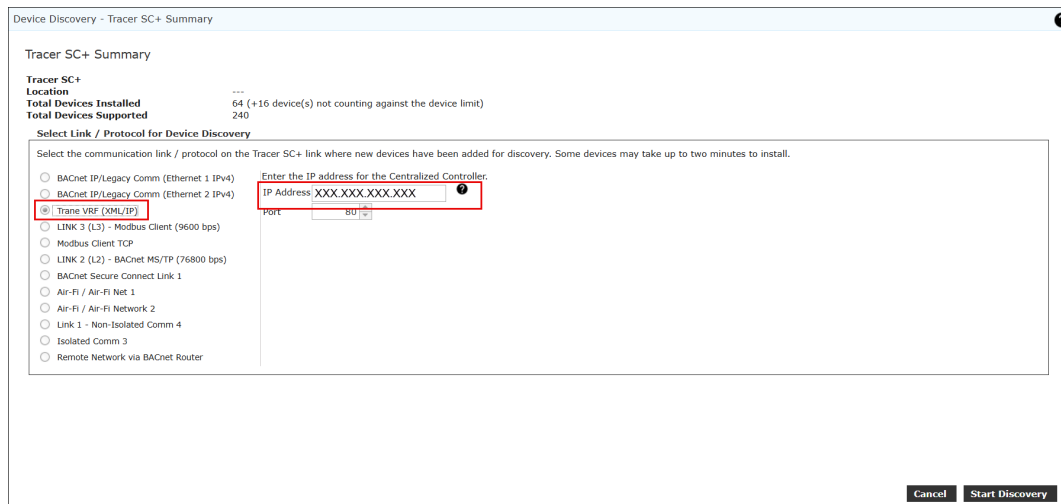

- Click **Start Discovery** on the bottom right portion of the screen.
- After discovery is complete, click

A list of discovered VRF devices should appear similar to what is shown in the following figure. VRF devices that can be auto-installed will have a green check mark in the Status column. Other VRF devices can be installed after a template is manually assigned or custom created.

**Figure 3. Discovered VRF device list**

Device Discovery - Define Equipment for Devices ?

Discovered Link Trane VRF (XML/IP)  
 Previously Installed Devices 0  
 New Devices Found 4

[Define for Installation: 4 Devices](#)

**Actions...** Select devices and then click actions to either create a new template, or to apply an existing template.

<input type="checkbox"/>	Display Name	Device Name	Model	M-NET Address	Group	Maintenance Data	Equipment Template	Status
<input checked="" type="checkbox"/>	uno	VRF_10.28.12.50:80_1	Indoor Unit (IC)	1	1	Enabled	Will Auto Install	✓
<input checked="" type="checkbox"/>	dos	VRF_10.28.12.50:80_2	Indoor Unit (IC)	2	2	Enabled	Will Auto Install	✓
<input checked="" type="checkbox"/>	VRF_10.28.12.50:80_51	VRF_10.28.12.50:80_51	Outdoor Unit (OC)	51	0	Enabled	Will Auto Install	✓
<input checked="" type="checkbox"/>	VRF_10.28.12.50:80_52	VRF_10.28.12.50:80_52	Branch Controller (BC)	52	0	Enabled	Will Auto Install	✓

- Change the display name of the discovered devices (optional). Display names can also be changed after installation.
  - Click the checkbox to the left of the **Display Name** column of a VRF devices.
  - Click **Actions**, then select **Change Display Name**.
- Make sure all devices to be installed have been selected, and then click **Install Selected Devices**.  
 After a few minutes all of the selected VRF devices will be installed.

**“Complete the VRF Integration,” p. 27**

- Verify the VRF data and control of the VRF system through Tracer® SC+/Synchrony.
- Assign a specific Indoor Unit graphic or modify the default equipment graphics (optional).
- Set up control logic using Area, Scheduling, TGP2, or other Tracer® SC+ applications (optional).
- Integrate the VRF data into Tracer® Ensemble (optional).

# Prepare the VRF System

**Important:** Most integration issues are due to the VRF system NOT set up correctly.

The Mitsubishi Electric VRF controls system uses MNET communications between the indoor units, branch controller, and outdoor unit. The outdoor unit uses a separate MNET communication link to connect outdoor units and the centralized controller. Centralized controllers use Ethernet port 1 to communicate to other centralized controllers, to access web pages, and to communicate to Tracer® SC+ using the Tracer SC+ VRF license.

**Figure 4. MNET communication diagram**

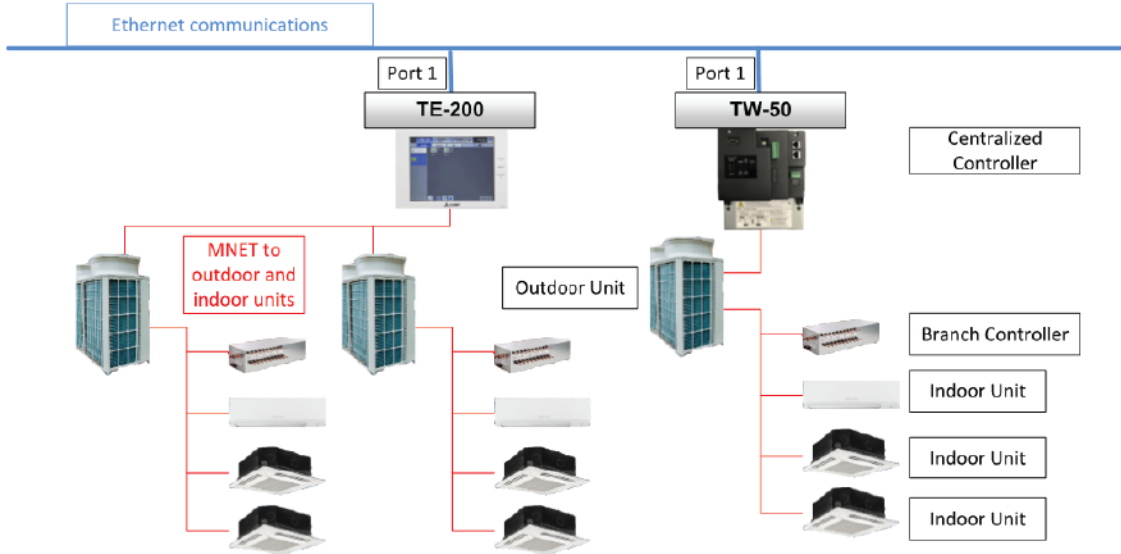

The Mitsubishi Electric VRF system must be fully configured and operational with a Centralized Controller before integrating to Tracer SC+. Tracer SC+ “learns” about the VRF system by querying the Centralized Controller during its discovery process. If changes are made to the Centralized Controller that would affect the VRF equipment configuration, another Tracer SC+ discovery or device refresh must be performed.

For detailed information on how to configure a Centralized Controller, refer to the appropriate Centralized Controller Detailed Operations literature that can be found on the Trane MyLinkDrive controls website: <http://trane.mylinkdrive.com/USA/Controls>.

There are specific Centralized Controller configuration concepts and options that are particularly relevant when using the Tracer SC+ VRF Integration license:

- The Centralized Controller must use a minimum firmware revision of 7.80. Earlier versions will not allow the Centralized Controller to provide maintenance data to Tracer SC+ You can find the Centralized Controller firmware version by clicking on the display (T/AE-200 or T/AE-50 only) service wrench icon in the upper right portion of the screen, which opens the and getting the login screen (See Figure 5, p. 12).



Figure 7. Mitsubishi Electric (initial settings tool)

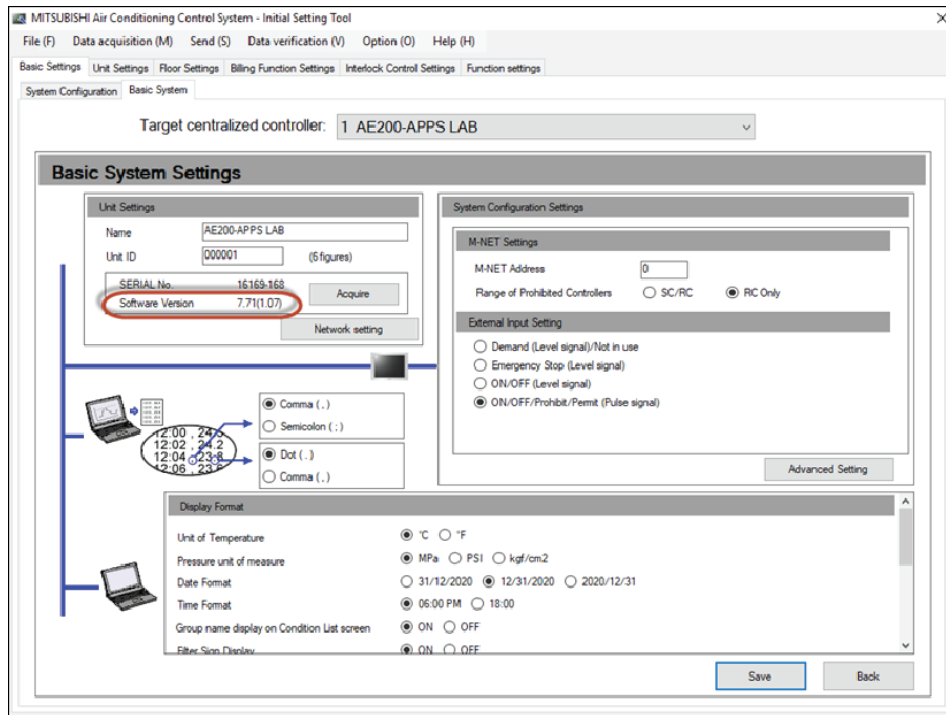

- All Indoor Units (IDUs) must be set up in a group. It is common to have a separate group for each IDU. However, multiple IDUs may be configured to be in the same group. All IDUs that share the same sensor (hardwired MA or communicating Smart ME) must be in the same group. This is most commonly done when multiple devices serve the same area and they should be in the same mode, or use the same remote controller. Up to 16 VRF controllers can be in a single group.

**Note:** The IDU data shown for a group of multiple IDUs will be from the IDU with the lowest MNET address.

A Smart ME remote controller is a MNET communicating remote controller. Optionally, it can be put into a group with IDUs. Tracer SC+ will only have the capability to integrate the Smart ME remote controller if it is placed into a Centralized Controller Group.

- Tracer SC+ queries each VRF equipment controller and displays specific points based on the configuration of the VRF equipment controller. It is very important to finalize the configuration of the VRF equipment before integrating with Tracer SC+ in order to minimize integration time.

Following are Centralized Controller configurations that will impact Tracer SC+ points:

- Use of dual or single setpoint. Most IDUs use dual setpoints by default. The use of dual setpoints is recommended but if the customer is insistent on using single setpoints, the Centralized Controller can force all the IDUs to use single setpoints by changing the Old model compatibility mode to ON (See Figure 8, p. 14).

**Figure 8. Advanced setting (old model capability mode)**

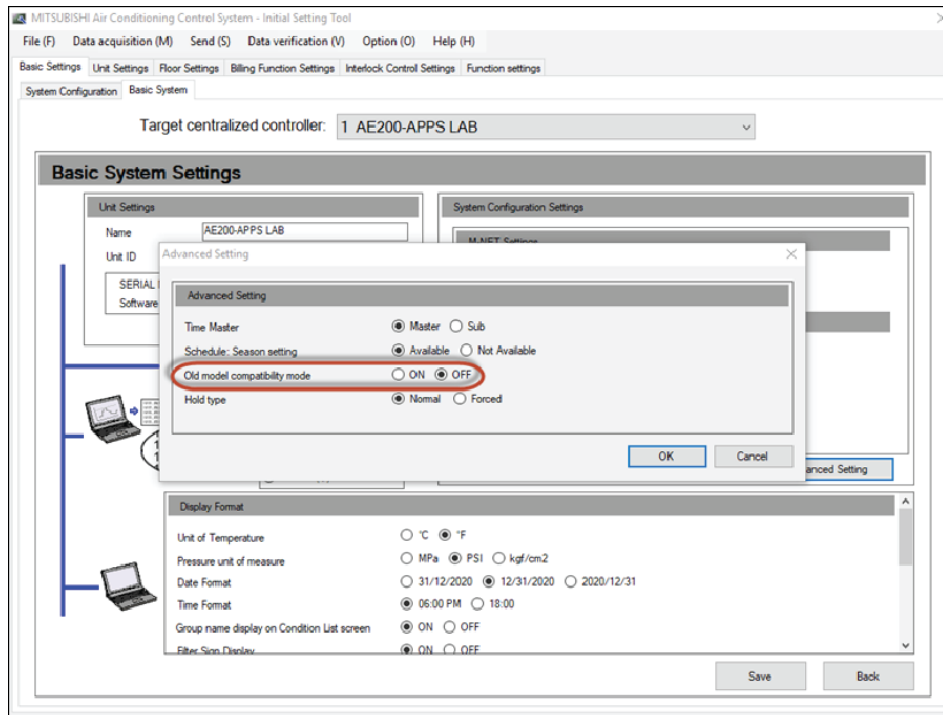

- Units of measure should be configured properly before integrating into Tracer SC+. If not, Tracer SC+ will not convert units of measure properly.
- Any other IDU configuration changes that might affect the following parameters:
  - Auto Mode Available (enabled/disabled).
  - Auto Mode Type (Single, Dual, or Disabled).
- **Note:** Auto Mode (Single Setpoint) is NOT a recommended configuration.
- Group Generation (Old/New).
- All other configurations such as adjusting the deadband or other low level function changes, should be done before integrating to Tracer SC+. These configuration changes will not impact Tracer® SC+ integration directly, but will affect the VRF system operation and can cause confusion when viewing the VRF system data on the user interface.

Following are several configuration parameters that can only be changed using Mitsubishi Electric tools (Maintenance Tool) but will affect the way a customer may interact with the VRF system:

- Auto Mode (Single) Differential.
- Auto Mode (Dual) Range.
- Deadband.
- Secondary Heater Differential.
- Enable Auto-Restart.

**Important:** The VRF system is read and setup by the ODU. This system information is read by the Centralized Controller which provides the integration data to Tracer SC+. If the ODU or Centralized Controller's "database" is out of sync with the actual VRF system, not all the data will be passed to Tracer SC+. If the ODU needs to be updated, refer to the ODU IOM documentation on how to reset the ODU properly. If the Centralized Controller needs to be updated, power cycle the Centralized Controller and watch it update the system on reboot. It is very important that the ODU and Centralized Controller have the current "database" BEFORE integrating to Tracer SC+.

Contact Mitsubishi Electric Customer Care Advisor at 800-433-4822 for VRF equipment or VRF controls setup questions.



# Enable Maintenance Data

Version 5.8 SP1 introduced the ability to automatically enable Maintenance Data within Synchrony during device installation. This eliminates the need to perform step three in the quick start guide for installing VRF equipment on an SC+.

Now, when the user initiates a discovery of Trane VRF devices in Synchrony, the system automatically enables Maintenance Data for supported devices.

In the Maintenance Data column, most devices will display **Enabled**, while a few Smart ME devices may show **No Additional Data**. Both are normal states, confirming that Maintenance Data is enabled. If any other status displays, there is an issue preventing Maintenance Data from being enabled, at it should be addressed before proceeding to avoid rework and missing data issues.

## Steps to enable Maintenance Data

1. Start Discovery.

Figure 9. Device Discovery

Device Discovery - Tracer SC+ Summary

Tracer SC+ Summary

Tracer SC+ Tracer SC+ - E23J00236  
Location WBL  
Total Devices Installed 4  
Total Devices Supported 30

Select Link / Protocol for Device Discovery

Select the communication link / protocol on the Tracer SC+ link where new devices have been added for discovery. Some devices may take up to two minutes to install.

Trane\_VRF (XML/IP)  
 Modbus TCP  
 LINK 1 (L1) - BACnet MS/TP (76800 bps)  
 LINK 2 (L2) - BACnet MS/TP (76800 bps)  
 Isolated Comm 3  
 Remote Network via BACnet Router

Enter the IP address for the Centralized Controller.  
IP Address   
 Enter Centralized Controller Login Credentials  
Username   
Password

Cancel Start Discovery

2. Being installation of devices.

## Enable Maintenance Data

Figure 10. Discovery Completed

Device Discovery - Discovery Completed

Tracer SC+ Summary

Tracer SC+ Tracer SC+ - E23J00236  
 Location WBL  
 Total Devices Installed 4  
 Total Devices Supported 30

Discovery Completed

Discovering Link Trane VRF (XML/IP)  
 Discovery Status Discovery Completed  
 Devices Found 4  
 New Devices Found 4

Click **install devices** to view discovered devices and select them for equipment installation.

Cancel Discovery Re-Discover **Install Devices**

3. Verify the status of Maintenance Data and complete installation of devices.

Figure 11. Define Equipment for Devices

Device Discovery - Define Equipment for Devices

Discovered Link Trane VRF (XML/IP)  
 Previously Installed Devices 0  
 New Devices Found 4  
[Define for Installation: 4 Devices](#)

**Actions...** Select devices and then click actions to either create a new template, or to apply an existing template.

<input type="checkbox"/>	Display Name	Device Name	Model	M-NET Address	Group	Maintenance Data	Equipment Template	Status
<input checked="" type="checkbox"/>	uno	VRF_10.28.12.50:80_1	Indoor Unit (IC)	1	1	Enabled	Will Auto Install	<input checked="" type="checkbox"/>
<input checked="" type="checkbox"/>	dos	VRF_10.28.12.50:80_2	Indoor Unit (IC)	2	2	Enabled	Will Auto Install	<input checked="" type="checkbox"/>
<input checked="" type="checkbox"/>	VRF_10.28.12.50:80_51	VRF_10.28.12.50:80_51	Outdoor Unit (OC)	51	0	Enabled	Will Auto Install	<input checked="" type="checkbox"/>
<input checked="" type="checkbox"/>	VRF_10.28.12.50:80_52	VRF_10.28.12.50:80_52	Branch Controller (BC)	52	0	Enabled	Will Auto Install	<input checked="" type="checkbox"/>

Cancel Installation Install Selected Devices

To additional features allow technicians to toggle the Maintenance Data. This is useful if new devices are added to the site or if some devices did not enable Maintenance Data initially. To toggle the maintenance data:

1. Navigate to the **Devices** section.
2. Select the **VRF XML/IP** tab.
3. Select the equipment to toggle.
4. Click the **Actions** button.
5. Select **Turn off Maintenance Data**.
6. Wait a few minutes, then repeat Steps 1–4.
7. Select **Turn on Maintenance Data**.

**Figure 12. Toggle Maintenance Data**

The screenshot shows the 'Devices' page in the Trane web interface. The 'VRF (XML/IP)' tab is selected and highlighted with a red box. The 'Actions...' dropdown menu is open, and 'Turn on Maintenance Data' is highlighted with a red box. The table below shows a list of devices with their IP addresses, M-NET addresses, groups, equipment templates, communication statuses, and maintenance data settings.

IP Address	M-NET Address	Group	Equipment Template	Communication Status	Maintenance Data		
10.28.12.50:80	2	2	Auto Assigned	Communicating	Enabled		
10.28.12.40:44	1	1	Auto Assigned	Communicating	Enabled		
10.28.12.40:44	2	2	Auto Assigned	Communicating	Enabled		
10.28.12.50:80	1	1	Auto Assigned	Communicating	Enabled		
VRF_10.28.12.40:44	Outdoor Unit	10.28.12.40:44	51	0	Auto Assigned	Communicating	Enabled
VRF_10.28.12.40:44	Branch Controller	10.28.12.40:44	52	0	Auto Assigned	Communicating	Enabled
VRF_10.28.12.50:80	Outdoor Unit	10.28.12.50:80	51	0	Auto Assigned	Communicating	Enabled

# Identify Customer Network Security Needs

One benefit of providing a BAS for a VRF system is to provide a secure architecture with remote access. Tracer® SC+ has many security mechanisms in place and is continually updated with new security features. For this reason, it is recommended the Centralized Controller not be directly on the customer's IP network.

**Connect the Centralized Controller port 1 to Tracer SC+ port 2.** This offers a layer of protection between the customer's IP network and the Centralized Controller, while still providing the customer secure remote access using Trace SC+ and Trane Connect. This is a similar architecture used by Tracer SC+ with Trane BCUs or BMTB products. See *Tracer SC+ System Controller with the Tracer Synchrony User Interface Installation, Operation, and Maintenance (BAS-SVX077\*-EN)*, for more information on configuring Tracer SC+ in a secure manner.

**Figure 13. Recommended Trane Mitsubishi Electric VRF system architecture diagram**

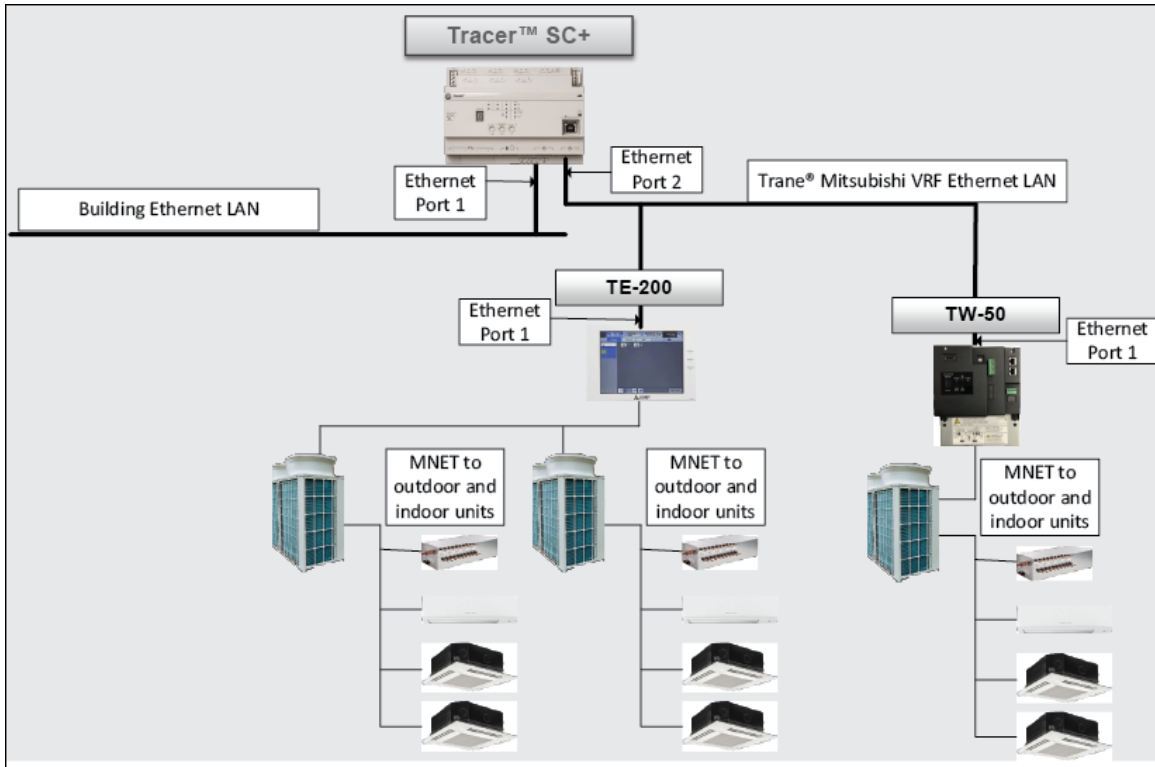

An alternate less secure architecture connects the Centralized Controllers and Tracer® SC+ port 1 directly on the customer's IP network. This architecture trades security for ease of installation and access to the Centralized Controllers via the customer's IP network.

Figure 14. Lower security Trane Mitsubishi Electric VRF system architecture diagram

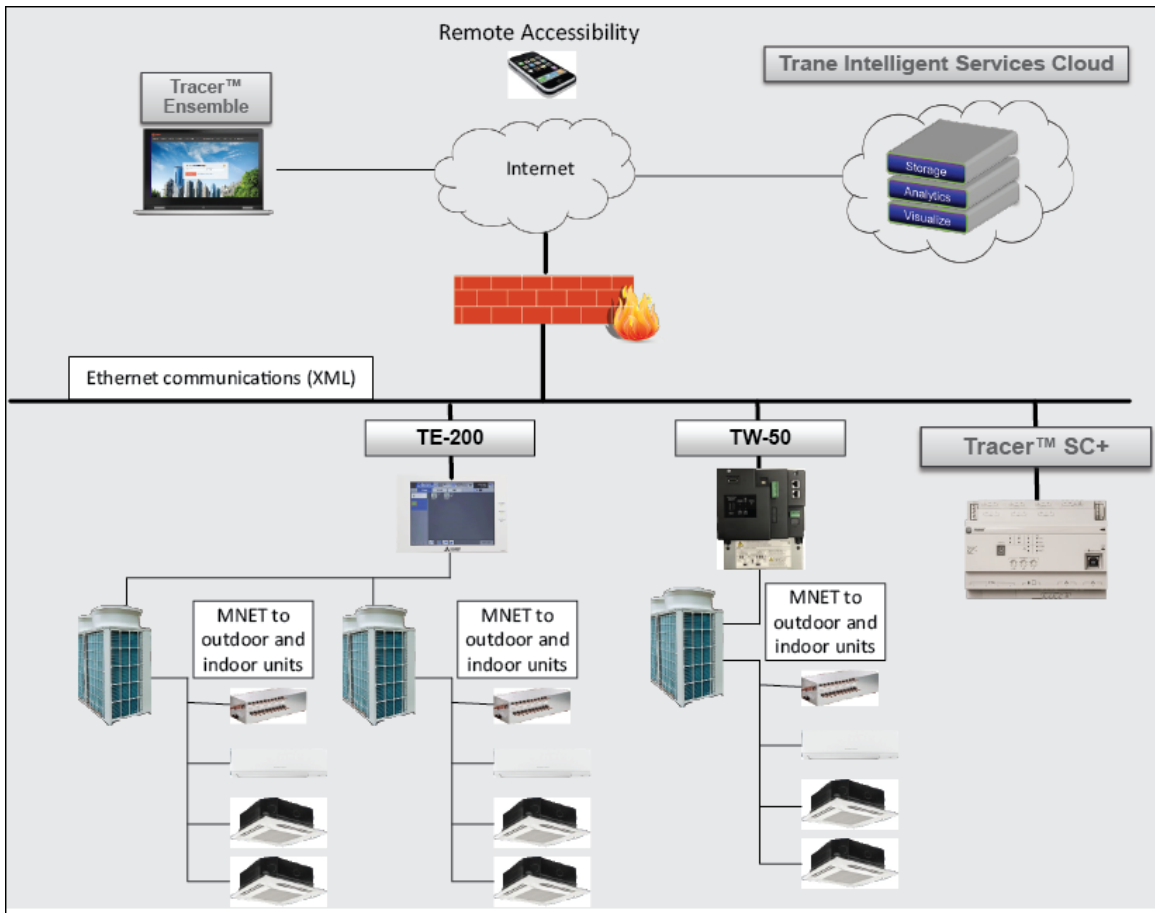



# Discover and Install VRF Devices in Tracer® SC+

After the VRF system is completely configured and all controllers are communicating in the preferred architecture, the next step is to discover and install the VRF devices with Tracer® SC+.

**Important:** Use the Trane Enable Maintenance Data tool to enable maintenance data before using Tracer SC+ to integrate the VRF system. If not, the maintenance data will not be discovered.

Tracer SC+ must have a Trane VRF Integration license and device licenses for each VRF equipment controller in order to integrate Mitsubishi Electric VRF systems. See *Tracer SC+ System Controller with the Tracer Synchrony User Interface Installation, Operation, and Maintenance (BAS-SVX077\*-EN)*, for more information on how to license Tracer SC+.

## Discovering VRF Devices

After Tracer® SC+ is properly licensed, use the Tracer® Synchrony user interface (UI) to navigate to the Device Discovery page. See *Tracer® SC+ System Controller with the Tracer® Synchrony User Interface Installation, Operation, and Maintenance (BAS-SVX077\*-EN)*, for detailed procedures.

### To discover devices:

1. From the left navigation menu on the Tracer® Synchrony UI, click **Devices > Discover Devices**.
2. Select **Trane VRF (XML/IP)** and then enter the IP address of the Centralized Controller (See [Figure 15, p. 20](#)).

If you have multiple Centralized Controllers, you must repeat the discovery and installation steps for each Centralized Controller. This is always the case with multiple Centralized Controllers even if the T/AE-200 Centralized Controller is set up for system expansion for multiple Centralized Controllers. The Port will always be configured to 80 until further notice.

**Figure 15. Device discovery in Tracer Synchrony**

Tracer SC+	Tracer SC+ -
Location	WBL
Total Devices Installed	8
Total Devices Supported	30

Select Link / Protocol for Device Discovery

Select the communication link / protocol on the Tracer SC+ link where new devices have been added for discovery. Some devices may take up to two minutes to install.

Trane VRF (XML/IP)

Modbus TCP

LINK 1 (L1) - BACnet MS/TP (76800 bps)

LINK 2 (L2) - BACnet MS/TP (76800 bps)

Isolated Comm 3

Remote Network via BACnet Router

Enter the IP address for the Centralized Controller.

IP Address: 10.13.24.144

Enter Centralized Controller Login Credentials

Username: \_\_\_\_\_

Password: \_\_\_\_\_

3. Click **Start Discovery**. Tracer® SC+ searches for a unique device for each VRF device that has been set up in the Centralized Controller (See [Figure 16, p. 21](#)).

**Figure 16. Device discovery complete**

Device Discovery - Discovery Completed

---

Tracer SC+ Summary

<b>Tracer SC+</b>	Tracer SC+
<b>Location</b>	WBL
<b>Total Devices Installed</b>	0
<b>Total Devices Supported</b>	30

Discovery Completed

<b>Discovering Link</b>	Trane VRF (XML/IP)
<b>Discovery Status</b>	Discovery Completed
<b>Devices Found</b>	4
<b>New Devices Found</b>	4

Click **install devices** to view discovered devices and select them for equipment installation.

4. Click **Install Devices**. A list of the discovered devices displays (See Figure 17, p. 21).

**Figure 17. List of discovered devices**

Device Discovery - Define Equipment for Devices

---

Discovered Link Trane VRF (XML/IP)  
 Previously Installed Devices 0  
 New Devices Found 4

[Define for Installation: 4 Devices](#)

**Actions...** Select devices and then click actions to either create a new template, or to apply an existing template.

<input type="checkbox"/>	Display Name	Device Name	Model	M-NET Address	Group	Maintenance Data	Equipment Template	Status
<input checked="" type="checkbox"/>	IDU-1	VRF_10.28.12.40:443_1	Indoor Unit (IC)	1	1	Enabled	Will Auto Install	✓
<input checked="" type="checkbox"/>	IDU-2	VRF_10.28.12.40:443_2	Indoor Unit (IC)	2	2	Enabled	Will Auto Install	✓
<input checked="" type="checkbox"/>	VRF_10.28.12.40:443_51	VRF_10.28.12.40:443_51	Outdoor Unit (OC)	51	0	Enabled	Will Auto Install	✓
<input checked="" type="checkbox"/>	VRF_10.28.12.40:443_52	VRF_10.28.12.40:443_52	Branch Controller (BC)	52	0	Enabled	Will Auto Install	✓

Cancel Installation
Install Selected Devices

5. Change the VRF device name.

The default name for each device is: **VRF\_<IP Address of Centralized Controller>:<Port>\_<MNET Address>**. The names in the Centralized Controller cannot be imported into Tracer® SC+. Each VRF device to be installed must be renamed appropriately.

6. Ensure that all devices to be installed have been selected, and then click **Install Selected Devices**. It may take several minutes for all devices to install.



## Discover and Install VRF Devices in Tracer® SC+

---

It is best practice to verify the discovery results with what was expected to be discovered. The Model and MNET Address information is a good way to identify all the VRF equipment controllers that were discovered. Each indoor unit will be in a Group with a non-0 group number.

Multiple indoor units and remote controllers may be in the same group as described in the “Prepare the VRF System,” p. 11. Devices, such as outdoor units and branch controllers, cannot be in a group and will display a group number of 0 to indicate they are not part of a group. For more information on Groups and how they are used in the Mitsubishi Electric VRF system, refer to the T/AE-200 Centralized Controller on Trane MyLinkDrive: <http://trane.mylinkdrive.com/USA/Controls>.

### Auto-installed Devices

If Tracer® SC+ has a factory template for a specific device, the status will display a green checkbox. These devices can be immediately installed.

The following is a list of supported (auto-installed) VRF devices:

- Indoor Units
- Outdoor Units (Main and Sub), air-cooled
- Branch Controllers (Main and Sub)
- Remote Controller (ME)
- Lossnay (Mitsubishi Electric ERV)
- HEX (heat exchanger).

It is best practice to auto-install VRF devices using the factory templates. Additional template editing may be done after installation and saved as a new template. Once a device uses a custom template, it will not automatically use updated factory templates that may be provided in future Tracer® SC+ software releases.

The exception to the above are the following VRF devices that benefit from using a custom template provided by the factory. These templates include some point differences and/or different graphics.

- LEV kit (defaults to using Indoor Unit template).
  - The LEV kit defaults to using discharge air temperature control but can be configured for space temperature control. The factory Indoor Unit template will work for space temperature control configurations, but the customer template should be used for discharge air control applications or it will install as a space with incorrect points
- Water-cooled Outdoor Unit (defaults to using air-cooled Outdoor Unit template).
  - The custom template will have updated point names and a water-cooled outdoor Unit graphic.

A third category of devices are those that do not auto-install and will require a new template to be created. These controllers are not commonly used by new VRF installations. It is recommended to only create a new template if the device must be integrated. Assigning a factory template that best fits, and then modifying the template will save time in most cases.

Examples of VRF devices that do not auto-install are listed below. See [Figure 18, p. 23](#), shows a VRF device discovery depicting this scenario.

- AIC (P-Series).
- AHC (Advanced HVAC Controller).
- Generic I/O controllers.

**Figure 18. Discovery list with VRF devices that will not auto install**

Device Discovery - Define Equipment for Devices ?

Discovered Link Trane VRF (XML/IP)  
 Previously Installed Devices 0  
 New Devices Found 44  
[Define for Installation: 44 Devices](#)

**Actions...** Select devices and then click actions to either create a new template, or to apply an existing template.

<input type="checkbox"/>	Display Name	Device Name	Model	M-NET Address	Group	Maintenance Data	Equipment Template	Status
<input checked="" type="checkbox"/>	119	VRF_10.28.12.60:80_19	Indoor Unit (IC)	19	19	Enabled	Will Auto Install	✓
<input checked="" type="checkbox"/>	102	VRF_10.28.12.60:80_2	Indoor Unit (IC)	2	2	Enabled	Will Auto Install	✓
<input checked="" type="checkbox"/>	120	VRF_10.28.12.60:80_20	Indoor Unit (IC)	20	20	Enabled	Will Auto Install	✓
<input type="checkbox"/>	121	VRF_10.28.12.60:80_21	P-Series Indoor Controller (AIC)	21	21	Enabled		Template assignment required
<input type="checkbox"/>	122	VRF_10.28.12.60:80_22	P-Series Indoor Controller (AIC)	22	22	Enabled		Template assignment required
<input type="checkbox"/>	123	VRF_10.28.12.60:80_23	P-Series Indoor Controller (AIC)	23	23	Enabled		Template assignment required
<input type="checkbox"/>	124	VRF_10.28.12.60:80_24	P-Series Indoor Controller (AIC)	24	24	Enabled		Template assignment required
<input type="checkbox"/>	125	VRF_10.28.12.60:80_25	P-Series Indoor Controller (AIC)	25	25	Enabled		Template assignment required
<input checked="" type="checkbox"/>	126	VRF_10.28.12.60:80_26	Lossnay ERV Controller (LC)	26	26	Enabled	Will Auto Install	✓
<input checked="" type="checkbox"/>	127	VRF_10.28.12.60:80_27	Lossnay ERV Controller (LC)	27	27	Enabled	Will Auto Install	✓
<input checked="" type="checkbox"/>	128	VRF_10.28.12.60:80_28	Lossnay ERV Controller (LC)	28	28	Enabled	Will Auto Install	✓
<input checked="" type="checkbox"/>	129	VRF_10.28.12.60:80_29	Lossnay ERV Controller (LC)	29	29	Enabled	Will Auto Install	✓

**Cancel Installation** **Install Selected Devices**

## Creating a VRF Template

Few projects require the creation of a new template. Creating a VRF template should only be done if you are unable to install and then edit the factory template. The factory template creates additional points for setpoint(s), occupancy, and mode that cannot be accomplished when creating a new template.

To create a VRF template:

1. Select a device that requires a template from the **Device Discovery** list.
2. Click **Actions**, then select **Create Template from Device**.
3. Change the Equipment Family and Type as appropriate (See [Figure 19, p. 24](#)).

A new equipment family of VRF with associated equipment types exists. The indoor unit equipment type can be found under the Space equipment family. Optionally, you can assign a graphic. See ["Graphics," p. 28](#), for more information on naming graphics.

**Figure 19. Create device from template**

4. Click **Next**. A list of XML/IP properties is displayed (See [Figure 20, p. 24](#)). A list of these property names are used in other factory templates and can be found in the “Point List,” [p. 43](#).

**Figure 20. Example list of properties when editing a VRF template**

<input type="checkbox"/>	Property	Data Type	Data Type	Device Value	Key	Point Value
<input type="checkbox"/>	Address	Integer	...	21		...
<input type="checkbox"/>	FanStatus	Boolean	...	ON		...
<input type="checkbox"/>	NightMode	Boolean	...	OFF		...
<input type="checkbox"/>	SaveValue	Float	...	51.0 %		...
<input type="checkbox"/>	SubHeaterStatus	Boolean	...	OFF		...
<input type="checkbox"/>	ThermoStatus	Boolean	...	ON		...

<input type="checkbox"/>	Property	Data Type	Data Type	Device Value	Key	Point Value
<input type="checkbox"/>	Address	Integer	...	21		...
<input type="checkbox"/>	MeterValue1		...			...
<input type="checkbox"/>	MeterValue2		...			...
<input type="checkbox"/>	MeterValue3		...			...
<input type="checkbox"/>	MeterValue4		...			...
<input type="checkbox"/>	SensorValue1		...			...

5. Map the keys according to best practices (see “[Best Practices when Creating New Equipment Templates,](#)” [p. 24](#)).

## Best Practices when Creating New Equipment Templates

- Properties are grouped into categories: Group Properties and Maintenance Data.

- **Group Properties:** As a rule, category names typically have no effect on the template. The exception are Group properties. Group properties are data that are shared by all members of the group. Therefore, if two indoor units are in the same group, they will show identical data values but a separate point will be created in Tracer® SC+ for each property assigned to use the template. The data values will originate from the indoor unit with the lowest MNET address. Example: if indoor unit-1 and indoor unit-2 are in Group 3, the Group property data on indoor unit-2 will actually be from indoor unit-1. Keep in mind that this only applies to the properties in the Group category.
- **Maintenance Data:** Maintenance data is critical data often used by VRF service technicians to troubleshoot issues and verify proper operation of VRF equipment (See [Figure 21, p. 25](#)). This data is only available if maintenance data was enabled. This data can be enabled or disabled in Synchrony This data is typically only accessible using the Mitsubishi Electric Maintenance Data (M-Tool) service software. All Maintenance data updates every 2 minutes.

**Figure 21. Maintenance data**

<input type="checkbox"/>	Property	Data Type	Data Type	Device Value	Key	Point Value	<input type="checkbox"/>
<input checked="" type="checkbox"/>	IC S	Enumeration	---		Indoor Coil Status (ICS)	Unknown	---
<input checked="" type="checkbox"/>	Li	Float	---		Indoor LEV Step Position(Li)	---	---
<input checked="" type="checkbox"/>	Mode	Enumeration	---		VRF Heat Cool Mode Status	---	---
<input checked="" type="checkbox"/>	ON OFF	String	---		On Off Status		---
<input checked="" type="checkbox"/>	Save	Float	---		Capacity Save Value	---	---
<input checked="" type="checkbox"/>	SC	Float	---		Subcool (SC)	---	---
<input checked="" type="checkbox"/>	SH	Float	---		Superheat (SH)	---	---
<input checked="" type="checkbox"/>	State	Enumeration	---		Occupancy Status	Occupied	---
<input checked="" type="checkbox"/>	State	Enumeration	---		VRF Operating Status	Unknown	---
<input checked="" type="checkbox"/>	TH1	Float	---		Space Temperature (TH1)	---	---
<input checked="" type="checkbox"/>	TH2	Float	---		Liquid Line Temperature (TH2)	---	---
<input checked="" type="checkbox"/>	TH3	Float	---		Gas Line Temperature (TH3)	---	---
<input checked="" type="checkbox"/>	TH4	Float	---		TH4	---	---
<input checked="" type="checkbox"/>	TO	Float	---		Space Temperature Setpoint Active	---	---

- Review the property names listed in the Appendix point list (See [“Point List,” p. 43](#)) in order to match the property with the appropriate key name. For example, the Li property shown in [Figure 21, p. 25](#) is currently reading 41 and according to the Indoor Unit point list, should be mapped to Indoor LEV Step Position (Li) as shown below:

**Figure 22. Maintenance data property key mapping**

<input type="checkbox"/>	Property	Data Type	Data Type	Device Value	Key	Point Value	<input type="checkbox"/>
<input type="checkbox"/>	Fan	Enumeration	---	Lo	Fan Stage	Low	---
<input type="checkbox"/>	IC S	Enumeration	---	Heat ON	Indoor Coil Status (ICS)	Heat ON	---
<input checked="" type="checkbox"/>	Li	Float	---	202	Indoor LEV Step Position(Li)	202.00	---

Notice that once the property was mapped, the key column shows the key used. The point value will display how Tracer® SC+ will show the Display Value after using the key and key conversion (if used).

- Most properties will have the data type field set. If there is not a data type entry for a property to be added to the template, it is a property not previously supported. You will need to know how the property data is formatted and enter the data type for the new property. It is recommended to contact Trane technical support for help updating the correct data type.
- Only add properties into the template that the VRF device supports and are necessary. Use the device value column to help identify useful properties. If there is no value in the device value field, the device does not support that property.

## Editing a VRF Equipment Template

Editing a VRF equipment template is very similar to creating a new VRF template, but differ with the following:

- Most of the properties will already be mapped to the proper keys according to the factory template used.
- The equipment family and equipment type cannot be changed when editing a template.



## Discover and Install VRF Devices in Tracer® SC+

---

- Do not remove controllable occupancy, setpoint(s), or mode properties. The factory template will create two points for each of these properties. If these properties have their mapping removed and then manually added, only a single point will be created. See “BAS and Arbitration Points,” p. 43 for more information.

See “Creating a VRF Template,” p. 23 for more information on VRF templates.

### To edit a VRF template:

1. From the left navigation menu, click **Devices**. The **Devices** list page opens.
2. Select the preferred device from the list and then select **Edit Template** from the **Actions** button.
3. Make your preferred changes to the template. The equipment family or type cannot be changed.  
If adding additional points:
  4. In the **Map Equipment Keys to Device Properties** section, select the equipment keys to map to the properties (points). If necessary, you can create additional equipment keys for points that cannot be mapped to a key.
  5. Click **Next**.
  6. Map any remaining points in the device, or create new keys if necessary.
  7. Click **Next**. The **Template Summary** Dialog opens.



# Complete the VRF Integration

## Verify the VRF Data

After the VRF system has been discovered and installed into the Tracer™ SC+, verify the VRF data and test control operations. Spot checking data on the VRF equipment pages or the Spaces page is a good place to verify data

The Spaces page has a new tab for VRF, which contains columns that are pertinent for VRF indoor units.

Figure 23. VRF space page (Tracer® Synchrony)

<input type="checkbox"/>	Name	Space Temperature	Active Setpoint	Discharge Air Temperature	Air Valve Position	Heat Cool Mode Status	Occupancy
No filter applied							
<input type="checkbox"/>	IDU-1	70.3 °F	72.0 °F			Heat	Occupied
<input type="checkbox"/>	IDU-2	77.0 °F	72.0 °F			Cool	Occupied

The VRF Spaces page is helpful for customers and technicians to quickly view the operation of the indoor units and to override multiple indoor units. To override indoor units from the VRF Spaces page, select one or more indoor units and click **Actions**. Select the control option from menu and then provide the new value to be sent to the selected indoor units.

Figure 24. VRF spaces page (override setpoint)

<input type="checkbox"/>	Name	Space Temperature	Active Setpoint	Discharge Air Temperature	Air Valve Position	Heat Cool Mode Status	Occupancy
No filter applied							
<input type="checkbox"/>	IDU-1	70.3 °F	72.0 °F			Heat	Occupied
<input type="checkbox"/>	IDU-2	77.9 °F	72.0 °F			Cool	Occupied

The *Override Space Temperature Setpoint* command will open a dialog box that will morph depending on the Setpoint Type field of the selected indoor unit(s). If the selected indoor units have single and dual Setpoint Types, the dialog box will allow entries for both single and dual setpoints. The **Show Devices** buttons may be selected to display the list of indoor units that use single or dual setpoints.

Figure 25. Multiple override dialog box

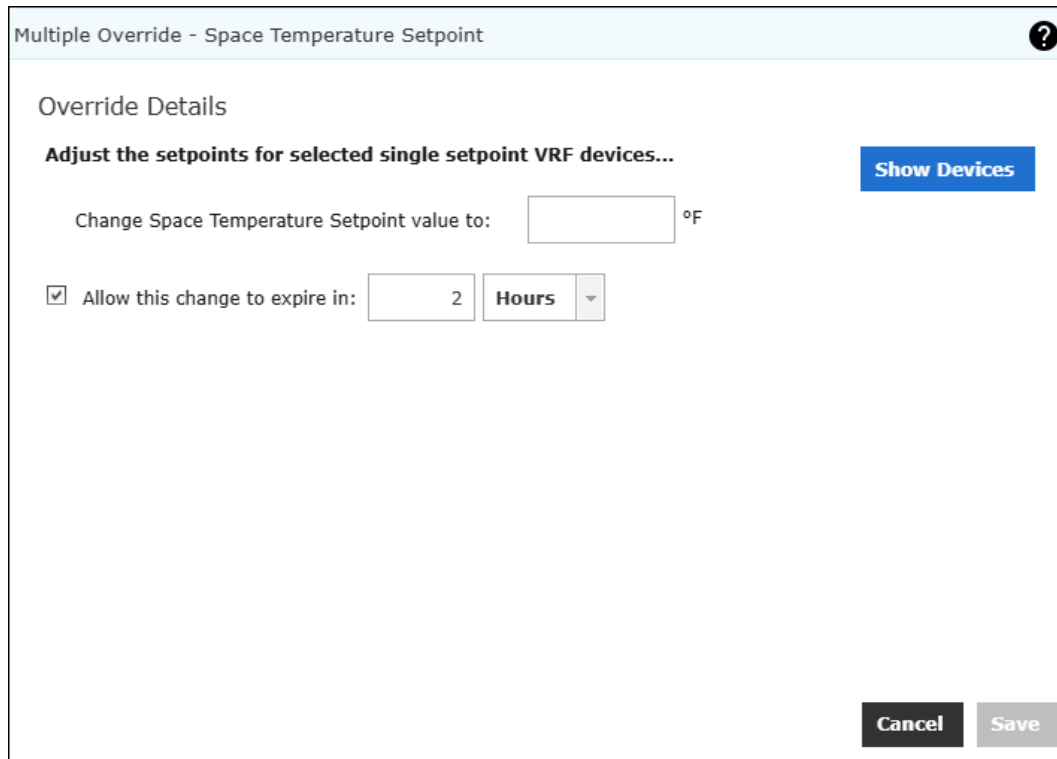

The screenshot shows a dialog box titled "Multiple Override - Space Temperature Setpoint" with a help icon in the top right corner. The main heading is "Override Details". Below it, the instruction reads "Adjust the setpoints for selected single setpoint VRF devices...". To the right of this instruction is a blue button labeled "Show Devices". The primary control is a text input field labeled "Change Space Temperature Setpoint value to:" followed by a numeric input box and the unit "°F". Below this, there is a checked checkbox labeled "Allow this change to expire in:" followed by a numeric input box containing the value "2", a button labeled "Hours", and a dropdown arrow. At the bottom right of the dialog are two buttons: "Cancel" and "Save".

## Graphics

Most VRF equipment controllers use a factory template with a default graphic. Indoor units use a standard graphic using a setpoint widget that will automatically change based on if the IDU supports single or dual setpoints. Most new installations will have indoor units configured to use dual setpoints.

To change the default graphic, edit the template and change the graphic assignment to the appropriate graphic.

### Creating a Custom Template

A custom template cannot be assigned to a device that has been installed. Make sure to edit the template for ALL similar indoor units at the same time to avoid editing each indoor unit template separately. Otherwise the VRF equipment must be deleted and reinstalled.

See "Creating a VRF Template," p. 23, to get started with the custom template creation.

Figure 26. Creating a custom template

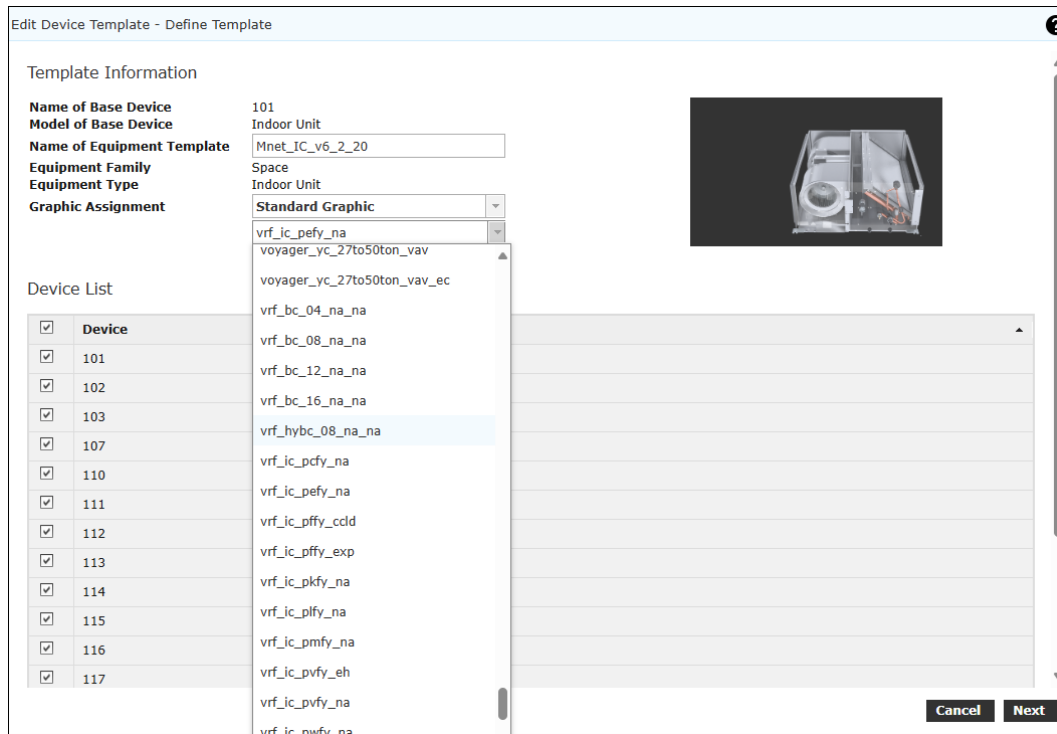

Standard graphics are named as follows:

**vrf\_<unit type>\_<model type>\_<unit options>**

**<unit type>**

- **ic** : indoor unit
- **oc** : outdoor unit
- **bc** : branch controller

**<model type>**

- **pcfy**: ceiling suspended indoor unit
- **pecfy**: ceiling concealed indoor unit
- **pffy**: floor mounted indoor unit
- **pkfy**: wall mounted indoor unit
- **plfy**: 4-way ceiling recessed indoor unit
- **pmfy**: 1-way ceiling recessed indoor unit
- **pvfy**: multi-position air handler
- **pwfy**: hydronic indoor unit
- **puhy**: outdoor unit

**<unit options>**

- **ac** : air cooled
- **ccl** : concealed
- **eh**: electric heat
- **exp**: exposed
- **na**: not applicable
- **wc**: water cooled

### Tracer® Graphics Editor (TGE)

Another option is to use TGE to import graphics as custom graphics into Tracer® SC+, and then editing the node(s) in the navigation tree.

**Figure 27. Using TGE to import standard graphics as custom graphics**

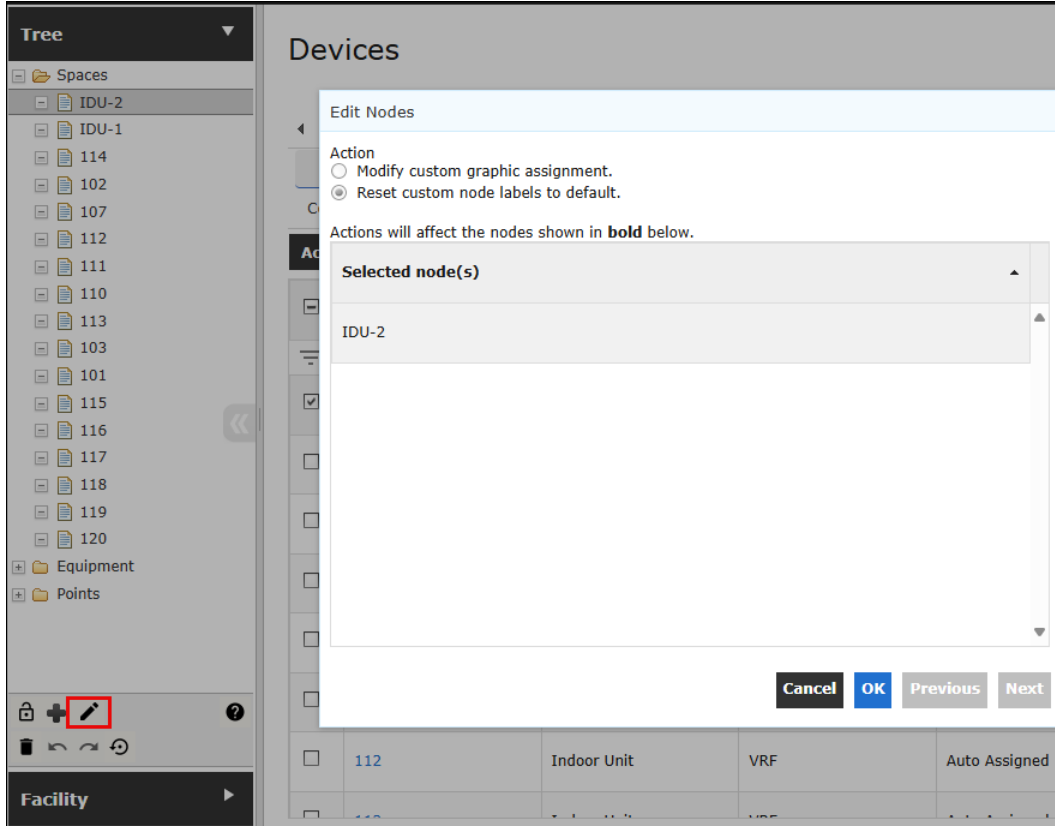

## Setting Up Control Logic

The VRF system is capable of controlling itself, but Tracer® SC+ can be set up to provide additional complex control of the VRF system. Only the indoor unit has controllable points and the VRF system will control the refrigeration system to meet the indoor unit setpoints. There are numerous options available to control the VRF system. This section will provide information on control options (Area control and Trim/Respond) that were designed to work with the VRF integration license.

### Unoccupied Temperature Control

#### **Option 1: Area control**

Area control can be used to provide unoccupied setup control to the VRF system. Many indoor units do not have unoccupied (or setback) setpoints, but Area control will operate regardless if the indoor unit supports setback setpoint. Area control will control the VRF indoor units in the same way as if they were VAV boxes from an occupancy and setpoint point of view. Because indoor units do not control ventilation, Area options for ventilation control should not be used.

## Creating an Area and adding Indoor Units as Members

Figure 28. Creating an area in Tracer Synchrony

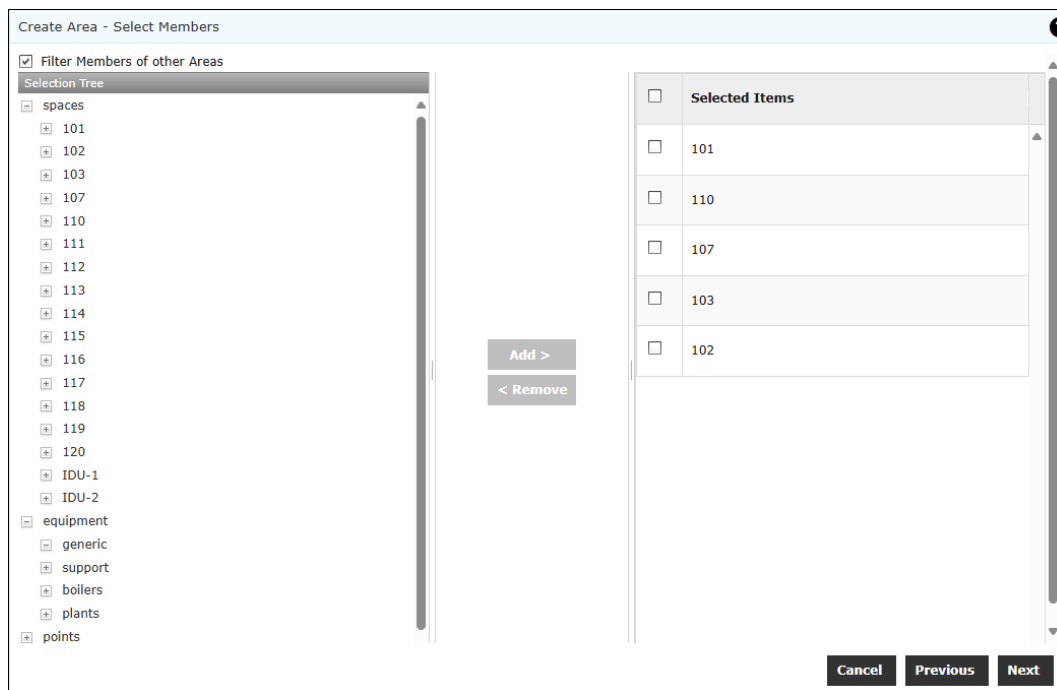

For most applications, it is recommended to use the Area default for the following parameters:

- Indoor units should be setup as Heating/Cooling member types, unless the VRF system is cooling only.
- The Space Temperature Sensor is referenced to the Area's Space Temperature Average.
- Synchronize area setpoints with members is set to Disabled.
  - Set the Unoccupied Heating and Cooling unit operations to Enabled.
  - **This feature will not work with dual setpoint indoor units.**
- The Area is typically put into a Schedule to control the Area member's occupancy.
- When the Schedule goes unoccupied, Area will go unoccupied.
- Area will control its members to unoccupied, which will cause the indoor units to turn OFF.
- If the average space temperature of the Area members goes above the Area's Unoccupied Cooling Setpoint or below the Area's Unoccupied Heating Setpoint, the Area will send an Occupied command to the indoor units.
- The indoor units will turn on and use control to their occupied (heating or cooling) setpoint. If the Space Temperature Average goes below the Unoccupied Cooling Setpoint or above the Unoccupied Heating Setpoint by the Unoccupied Differential (default is 4°F), the Area will go back to Unoccupied and shut off the indoor units

### Option 2: Schedule using Setback Mode

- Create a Multistate Schedule in Tracer Synchrony.
- Add the VRF Heat Cool Mode Arbitration point for each IDU to be controlled.
- Setup the Schedule to control to the 'Setback' state to put the IDU into Unoccupied temperature control and 'Auto' for Occupied temperature control.
- The IDU must be in Occupied mode in order to control the IDU to Setback or Auto modes. Recall that when the IDU is in Unoccupied mode, it will turn OFF.
- If the IDU is Occupied and in Setback mode, it will have a status of either Setback (Heating) or Setback (Cooling).
- Space Temperature Setpoint Active will use either the Unoccupied heating or cooling setpoints depending on the IDU heating or cooling mode.
- If the IDUs are also in Area, the Unoccupied Heating and Cooling unit operation setting must be set to Disabled.

## Trim/Respond Application

Trim/Respond may optionally be used to create control algorithms. Trim/respond provides flexibility to control VRF indoor units or to control other systems using VRF system information. If additional complexity is required, TGP2 can be used to control the indoor units.

## Refresh Equipment

The Refresh Equipment action will query the VRF device for configuration information (for example: dual or single setpoint usage) and will reapply the template.

The primary reason to refresh VRF devices is if the configuration has changed that will impact the points used by Tracer® SC+.

Common examples:

- Maintenance data was not enable in the Centralized Controller when the VRF system was installed into Tracer SC+
- The VRF system settings were changed that impact integration points (dual to single setpoint, VRF Equipment controller addressing, etc.).

**Figure 29. Refreshing equipment**

The screenshot shows the 'Devices' page in the Tracer SC+ interface. The 'Unit Controllers' tab is selected, and the 'Discover Devices' button is active. A dropdown menu is open over the table, with 'Refresh Equipment' highlighted. The table contains several rows of VRF indoor units, all with 'Auto Assigned' templates.

Equipment Type	Link	Equipment Template
Indoor Unit	VRF	Auto Assigned
Indoor Unit	VRF	Auto Assigned
Indoor Unit	VRF	Auto Assigned
Indoor Unit	VRF	Auto Assigned
Indoor Unit	VRF	Auto Assigned
Indoor Unit	VRF	Auto Assigned
Indoor Unit	VRF	Auto Assigned

The Refresh Equipment action on a VRF device reapplies the existing custom template but will not check for new configuration changes. If you need to revert back to the factory (Auto Assigned) template, select the VRF device and click the **Actions** button. Select **Assign Template** and use the default template as shown below.

Figure 30. Assigning a template

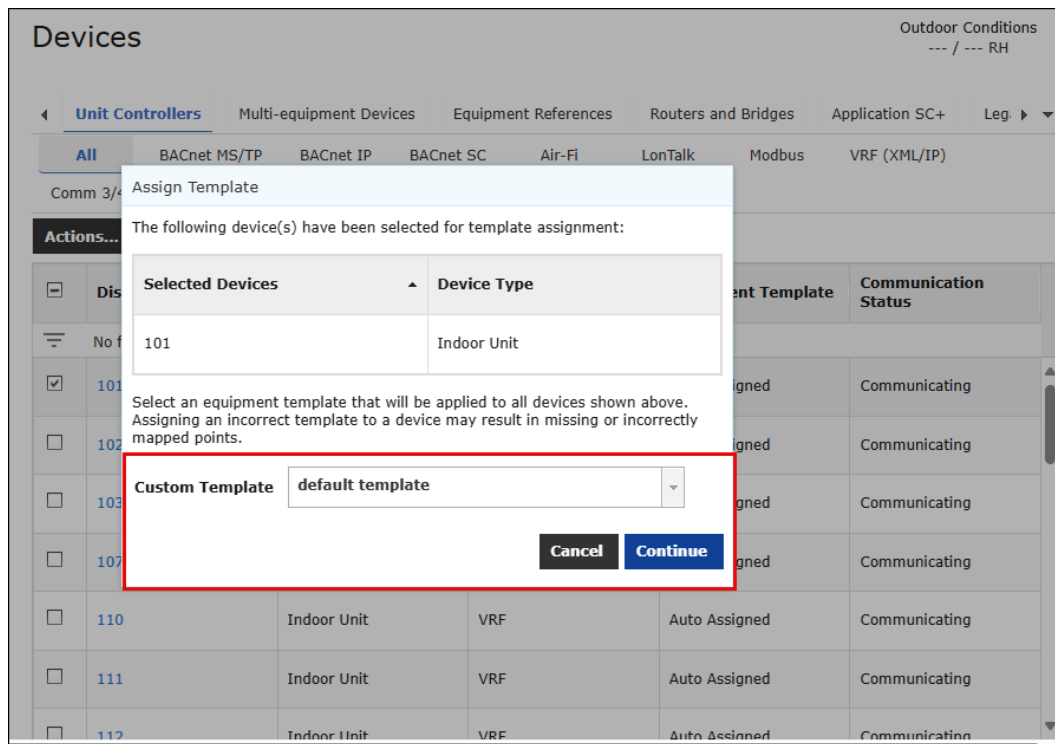

## Update Centralized Controller Settings

A Trane/Mitsubishi Electric VRF System integrates to the Tracer SC+ by connecting to the Mitsubishi Centralized controller. If the Centralized controller changes IP address or the username and password change, the Tracer® SC+ must be updated to continue communication to the devices.

If the login credentials or IP address of a Centralized Controller need to be updated, follow these steps for proper communication with the Tracer SC+ system.

VRF devices are installed by using the IP address of the Centralized Controller. If the IP address of the Centralized Controller changes after the devices are installed, Tracer® SC+ is unable to communicate to any of the VRF devices that were part of the Centralized Controller. The Action, “*Update IP Address of Centralized Controller,*” will update the IP address of Centralized Controller used by Tracer® SC+ communications.

## Update Login Credentials

1. Navigate to the **Devices** section.
2. Click the **VRF (XML/IP)** tab.
3. Check the device associated with the Centralized controller for which the IP address and/or credentials will be updated.
4. Select **Update Centralized Controller Settings**.

**Figure 31. Update Centralized Controller Settings**

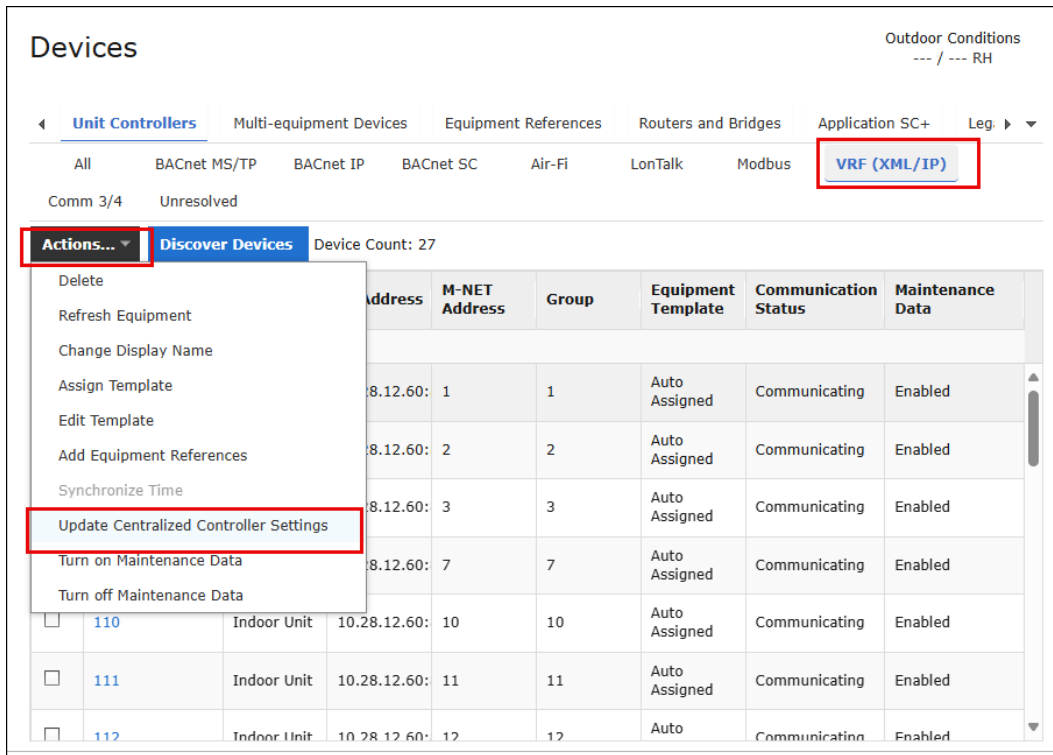

5. To update the username and password for a port 443 Centralized Controller:
  - a. The credential checkbox will be pre-checked and disabled, requiring the user to enter the new credentials before clicking the Apply button.
  - b. Enter the updated username and password.
  - c. Click **Apply**.
  - d. If the credentials are incorrect, an error message will appear with instructions on how to correct the issue.

## Update IP Address

1. Navigate to the **Devices** section.
2. Click the **VRF (XML/IP)** tab.
3. Check the device associated with the Centralized controller for which the IP address and/or credentials will be updated.
4. Select **Update Centralized Controller Settings**.
5. To update the IP address for a port 443 Centralized Controller:
  - a. The credential checkbox will be pre-checked and disabled, requiring the user to enter the new credentials before clicking the Apply button.
  - b. Enter the updated username and password.
  - c. Click **Apply**.
  - d. If the credentials are incorrect, an error message will appear with instructions on how to correct the issue.
  - e. If the IP address is invalid, an error message will appear with instructions on how to correct the issue.
6. To update the IP address for a port 80 Centralized Controller:
  - a. Credentials are not required, so the username and password fields will be hidden or disabled.
  - b. Enter the updated IP address.
  - c. Click **Apply**.
  - d. If the IP address is invalid, an error message will appear with instructions on how to correct the issue.

Figure 32. Update IP address

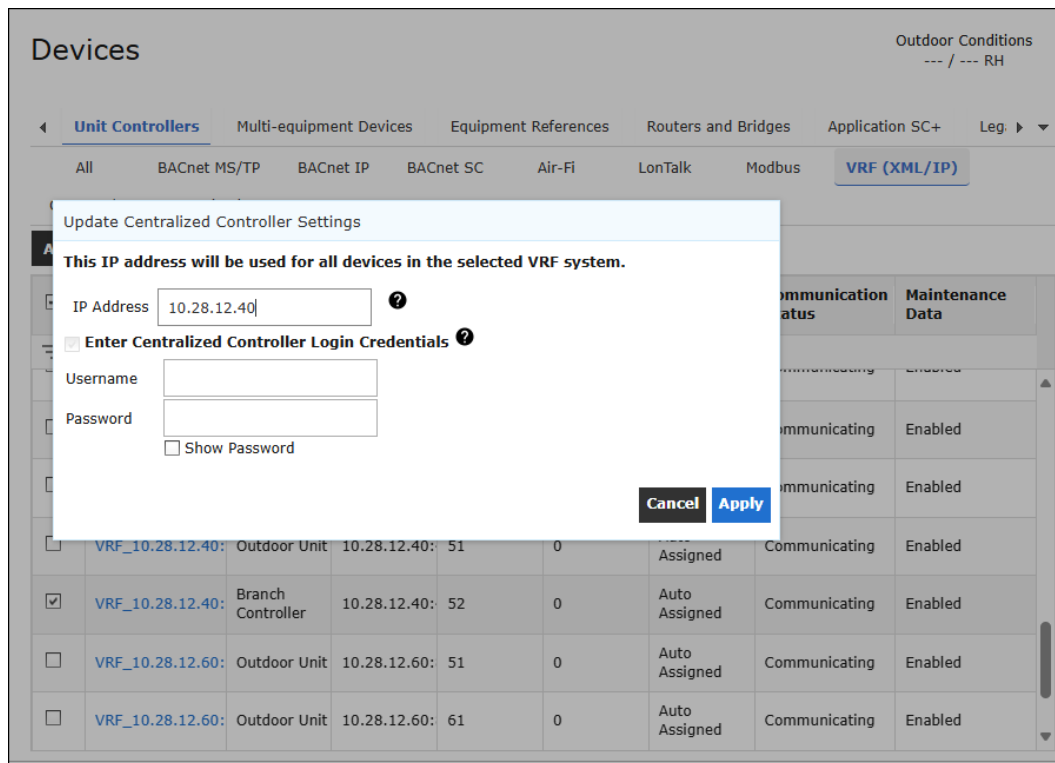

**Notes:**

- Update IP Address of Centralized Controller does not change the actual IP address of the Centralized Controller. Use the Centralized Controller display or other Mitsubishi Electric software tool to update the IP address..
- Confirm the user selected the correct Centralized Controller before making any updates.
- If no VRF devices are selected or if multiple VRF devices from different Centralized Controllers are selected, the "Update Centralized Controller Settings" action will not be available.

## Other Application Considerations

### DOAS (Dedicated Outdoor Air System) Control

The PPS Configurator Vault has DOAS TGP2 routines (VRF-DOAS-SC+\_Coordination) and a white paper (Whitepaper\_V1). Refer to the HUB for additional information on controlling a DOAS.

### Tracer® Ensemble

Tracer® Ensemble V6.0 and higher supports the VRF devices.

### Tenant Services

Tenant services can be used with VRF devices. Often, tenant billing can be done based on contractual rates with the tenants and does not require an energy meter.

It may be required to use an energy meter and calculate how much energy each IDU/tenant is using. Both options will require at least one energy meter to monitor the ODU energy usage:

- Obtain the Mitsubishi Electric LIC-Charge software license for the Centralized Controller. For more information on how to use and setup this feature, refer to the *Mitsubishi Electric Centralized Controller* Technical Manual.
- Use TGP2 to calculate energy usage per IDU/tenant. For more information including an application guide and sample TGP2, refer the *VRF Energy Allocation Application Guide* HUB.



## Complete the VRF Integration

---

Meter apportionment can be done using a meter on the outdoor unit(s) and assigning a percentage of the energy to each tenant. Specifications and local laws may impact what meter apportionment strategy is allowed in your area.

### Tracer® TU TGE

Tracer® TU V11.0.343 and higher support VRF devices. TGE can be used to create or modify graphics with VRF data.

**Note:** *The Trane Setpoint Control widget should not be used with VRF devices; use the Generic Setpoint Control widget.*

### 10-inch Display

The 10-inch display defaults to use the Trane Setpoint Control widget; it does not support VRF integration at this time. Refer to HUB DOC-191984 for more information.

### BAS Operator App

The BAS Operator App has been updated to work with the new VRF devices.

### Occupancy App

Because it uses the Trane Setpoint Control widget, the Occupancy App **does not** support VRF integration. Refer to HUB DOC-191984 for more information.

### Air-Fi® Integration

Air-Fi® is not currently supported with VRF devices.

The VRF system does not allow a communicated space temperature to be pushed from Tracer® SC+ to the indoor units. Indoor units use their local inlet temperature sensor opposed to the Air-Fi temperature sensor, which can create control issues and occupant confusion.



# Using the Trane/Mitsubishi Electric VRF License on an Existing Mitsubishi Electric VRF System

The Trane/Mitsubishi Electric VRF License provides a substantial amount of data from the Mitsubishi Electric VRF system. Customers with existing Mitsubishi Electric VRF systems may want to upgrade to use the Trane/Mitsubishi Electric VRF License in order to benefit from this data and other features Trane controls offer.

Additional considerations can be made for customers who want to upgrade to the VRF integration license. The following can be used as discussion points:

## No Existing BAS Integration

Verify that there is a Centralized Controller (T/AE-200, T/AE-50, or T/EW-50) running firmware 7.80 or higher. If not, a Centralized Controller must be provided and configured in order to work with the existing VRF system. Use the Tracer® SC+ with Trane/Mitsubishi Electric VRF License to integrate the VRF system as you would for a new project. Pay attention to the possibility that the existing VRF system may be using legacy VRF equipment controllers that are not auto-installed.

## Existing BACnet® Integration

Upgrading a VRF integration using the Mitsubishi Electric BACnet® license will require additional labor and increased cost estimates. Tracer® SC+ V5.4 or higher with Trane/Mitsubishi Electric VRF License will be required. This may mean a physical controller change (Tracer® SC or non-Trane system controller to Tracer® SC+) or a software upgrade to V5.4 or higher.

The next step is to identify the labor required to complete the integration. If the site can be created as a fresh installation, you can estimate the labor as you would for a new project. If an existing Tracer® SC+ was used to do the BACnet® integration, the BACnet® devices must be deleted as well as all graphics, programming, and applications, and recreated when the VRF system is integrated using the Trane/Mitsubishi Electric VRF License. This can be a substantial amount of labor depending on how the initial BACnet® integration was done. Options available to reduce the amount of labor include using standard graphics and fewer custom graphics, and programming when the integration is done using the Trane/Mitsubishi Electric VRF License.



# Integrating to Third-Party BACnet® Systems

The Tracer® SC+ Trane/Mitsubishi Electric VRF License provides much more VRF equipment data opposed to a BACnet® interface. Because Tracer SC+ converts the Mitsubishi Electric VRF equipment data into BACnet objects, some customers may see the value in using Trace SC+ to provide the data to an existing BAS.

Once you integrate the VRF system into Tracer SC+, you can run a System Points report and export it as a .CSV file for the BAS integrator. This report displays the Device Name as the Tracer SC+ device name because the BACnet point resides in Tracer SC+. The Point Owner column shows the device name of the VRF Equipment. Refer to the HUB for more information on the System Points report for a third party BACnet system (Hub 100044).

**Figure 33. Systems point report**

## System Points Report

Reports

< Saved Reports    Actions... To export the report, click actions.

Type System Points Run On Jul 23, 2025 05:16:29 PM CDT

System Points Report

Outdoor Conditions  
--- / --- RH

Point Type	Instance	Point Name	Device Id	Device Name	Device Point Name	Point Owner
No filter applied						
AI	1	Facility Outdoor Air Temperature	20000	Tracer SC+ - E23J00236	Facility Outdoor Air Temperature	Tracer SC+ - E23J00236
AI	2	Facility Outdoor Air Humidity	20000	Tracer SC+ - E23J00236	Facility Outdoor Air Humidity	Tracer SC+ - E23J00236
AI	845	Differential Pressure (PS1 ~ PS3)	20000	Tracer SC+ - E23J00236	Differential Pressure (PS1 - PS3)	VRF_10.28.12.40:443
AI	846	Alarm Code	20000	Tracer SC+ - E23J00236	Alarm Code	VRF_10.28.12.40:443
AI	847	High Pressure Sensor (P1)	20000	Tracer SC+ - E23J00236	High Pressure Sensor (P1)	VRF_10.28.12.40:443
AI	848	Intermediate Pressure Sensor (PS3)	20000	Tracer SC+ - E23J00236	Intermediate Pressure Sensor (PS3)	VRF_10.28.12.40:443
		Intermediate Temp of		Tracer SC+ -	Intermediate Temp of	



# Troubleshooting

Two VRF communication parameters exist that prevent excessive traffic to the Centralized Controller. These communication parameters should only be changed if there is communication loss alarm, which is more likely on large VRF site. The parameters can be found in the **Identification and Communications** page under the VRF XML Configuration Tab. It is recommended to enlist the help of Trane technical support when changing the parameters.

The **Response Timeout for the VRF link** is the amount of time (ms) Tracer® SC+ waits for a response from the Centralized Controller before it marks the Centralized Controller as not communicating. Larger values allow the Centralized Controller more time to respond, but may slow communications. The default is 10000ms.

The **Connection Timeout for VRF links** is the amount of time (ms) Tracer SC+ will wait for a response from the Centralized Controller to open a socket. Once the socket is confirmed to be open, Tracer SC+ can perform a XML request. The default is 2500ms. If a higher value is needed, it would indicate an IP network issue.

The **Retry Delay for VRF links** is the time (ms) Tracer SC+ waits between retry attempts when communication with the Centralized Controller fails. The default is 2000ms. A longer delay can reduce network load, while a shorter delay may speed up retries but increase network traffic.

The **Retry Count for VRF links** is the number of times Tracer SC+ will retry a failed request to the Centralized Controller. The default is two retries. Increasing the count allows more chances for communication but may slow down overall response time during failures.

**Figure 34. Identification and Communications page**

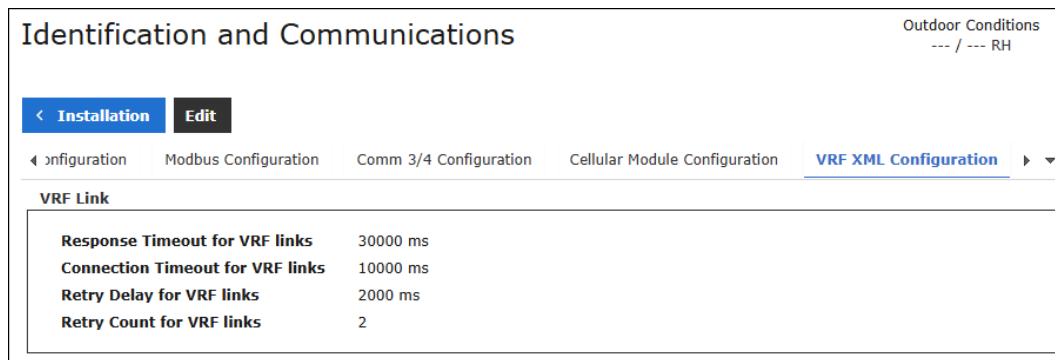

## Tools

There are a number of tools available to troubleshoot VRF integration projects. Mitsubishi Electric software tools can be found on the Trane MyLinkDrive controls website: <http://trane.mylinkdrive.com/USA/Controls>. Here is a list of tools and why they are typically used for VRF integration troubleshooting:

### Trane Enable Maintenance Data Tool

Maintenance Data can be enabled within Synchrony during device installation. This should be used to enable maintenance data before integrating the VRF equipment into Tracer® SC+.

In order to verify maintenance data has been enabled and is working properly, use Tracer Synchrony, select a VRF device, and click Actions and Edit Template. You may need to give the template a new name to get to the second page. There will be a list of VRF data in different sections. Look for data in a section called Maintenance Data Key Mapping. If you see this section, maintenance data has been enabled and is working properly.

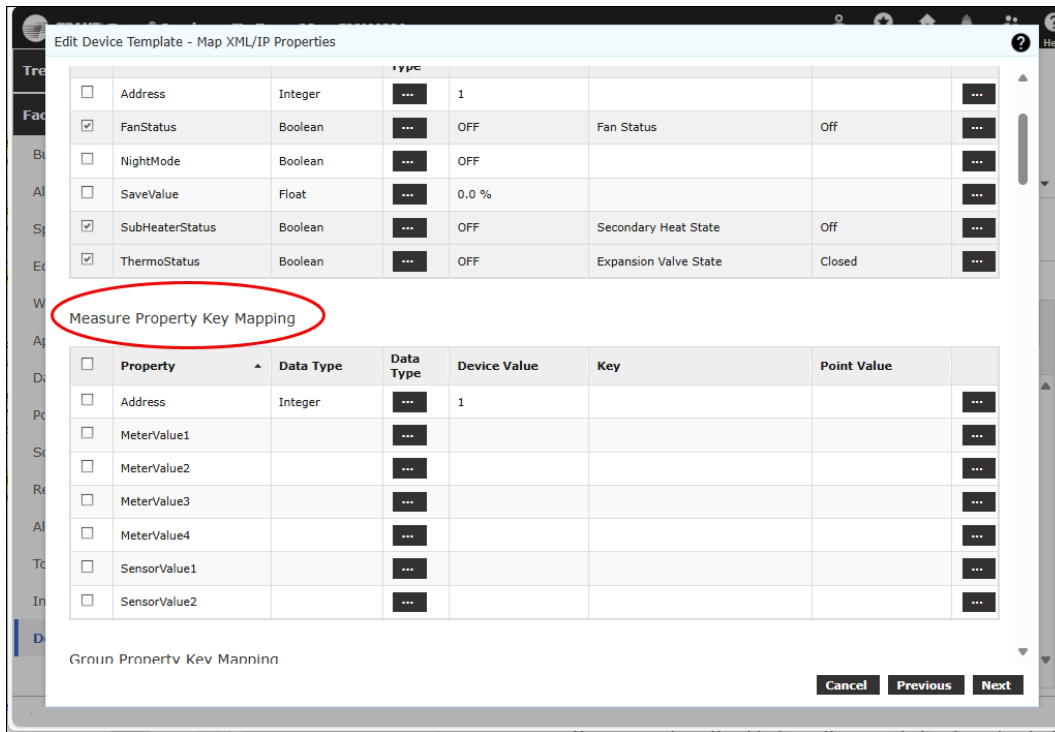
**Figure 35. Tracer Synchrony edit template screen**

## Maintenance Tool (M-Tool) for .NET

Maintenance Tool (M-Tool) for .NET is a Mitsubishi Electric software tool used by VRF service technicians. It is a powerful tool that scans a MNET link for devices, show maintenance/service level data, control function data, and other features to troubleshoot VRF systems. It is typically used to verify communications and maintenance data when troubleshooting VRF integration to Tracer® SC+.

**Note:** Maintenance Tool gets maintenance data from the VRF system differently than Tracer SC+ is allowed to do. Even if Maintenance Tool is getting maintenance data from the VRF system, it is NOT an indication that maintenance data was properly enabled using the Trane Enable Maintenance Data Tool.

## AE-200 Update Tool

This is a Mitsubishi Electric software tool used to update the firmware in Centralized Controllers.

## AE-200 Initial Settings Tool

This Mitsubishi Electric software tool is used to setup or view the configuration of Centralized Controllers. This tool can be used to configure Centralized Controllers online or offline. This is a great troubleshooting tool to verify or change the Centralized Controller configuration remotely or on a T/EW-50 which doesn't have a local display.

## Diamond System Builder (DSB)

This is a Mitsubishi Electric software tool to design a VRF system for both equipment and controls. Not typically used for troubleshooting VRF integration, but it can help to compare the MNET addressing used in Diamond System Builder to the current configuration in the Centralized Controller.

## Integrated Centralized Control Web Interface (ICCW)

This is the name of the web interface on the Centralized Controller. ICCW is not typically used when integrating to a BAS, like Tracer® SC+ but it is a tool that VRF specialists or METUS support ask to use for troubleshooting. The web interface can be accessed using the following URLs, assuming the Centralized Controller is using the default IP address on Port 1 or 192.168.1.1:

<http://192.168.1.1/control/index.html?en>

<https://192.168.1.1/control/index.html?en> . Secure connection, must install a certificate.

Default standard logon: **administrator**

Default standard password: **admin**

The web interface verifies the equipment data in the Centralized Controller and can be used to confirm Tracer® SC+ control of writable points.

A legacy JAVA-based web interface also exists on the Centralized Controller. Trane laptops will not allow this connection due to security concerns, therefore it is not supported. The default URL is <http://192.168.1.1> or <http://192.168.1.1/init/en/administrator.html> assuming a Centralized Controller IP address of 192.168.1.1 on Port 1.

Default standard logon: **initial**

Default standard password: **init**

**Note:** *Although the JAVA-based web interface is not supported, this information is included in the event a technician or user navigates to the URL by accident and attempts to connect.*



# Appendix

## Single, Dual, and Auto Setpoint(s)

Indoor units can be set up to support dual or single setpoints. Indoor units can also support an Auto mode, which has an impact on the setpoint(s) used as well as the mode. If an indoor unit is using Auto mode, it will either use a single setpoint or dual setpoints. Auto mode allows the indoor unit to change its mode automatically based on the difference between the space temperature and the active space temperature setpoint. When using Auto (dual) mode, the indoor unit will use the Occupied Heating and Cooling setpoints to determine mode. When using Auto (single) mode, the indoor unit will use a new setpoint called *VRF Space Temperature Auto Setpoint*.

Table 1, p. 42 shows three indoor unit configuration parameters that determine which setpoint(s) the indoor unit will use for temperature control. It is strongly advised not to use the configuration to use *VRF Space Temperature Auto Setpoint*. Using VRF Space Temperature Auto Setpoint will require changes to the standard indoor unit graphics. It has also created confusion with customers and technicians from a sequence of operation standpoint.

**Table 1. Indoor unit configuration parameters**

Group Generation (Group Type)	Auto Mode Type (Auto Mode SWEx)	Auto Mode Available (Auto Mode Sw)	Setpoint(s) Used
Old	—	—	Space Temperature Setpoint BAS
New	Single Setpoint	Yes	VRF Space Temperature Auto Setpoint
New	Single Setpoint	No	<b>Cooling Only:</b> Occupied Cooling Setpoint BAS VRF Occupied Cooling Setpoint OR <b>Heating Only:</b> Occupied Heating Setpoint BAS VRF Occupied Heating Setpoint
New	Dual Setpoint	—	Occupied Cooling Setpoint BAS VRF Occupied Cooling Setpoint Occupied Heating Setpoint BAS VRF Occupied Heating Setpoint
New (Default)	Disable (Default)	—	Occupied Cooling Setpoint BAS VRF Occupied Cooling Setpoint Occupied Heating Setpoint BAS VRF Occupied Heating Setpoint

All setpoints shown in the above table will control a VRF property according to the IDU point list. (See ). These VRF setpoint properties only allow a resolution of 0.5°C. Tracer® SC+ will automatically calculate this conversion. However, from a user perspective the 0.5°C resolution limitation may appear that the active setpoint differs by up to 1°F from the original setpoint.

## VRF Model Names and Factory Templates

**Table 2. VRF model names and factory templates**

Mitsubishi Electric VRF Model Abbreviation	VRF Model Name	Default Tracer® SC+ Factory Template
AHC	General HVAC Controller	—
AIC	A-Series Indoor Controller	Mnet_IC_vxxx
BC	Branch Controller	Mnet_BC_v5xxx
BS	Branch Sub Controller	Mnet_BS_v5xxx
New (Default)	Disable (Default)	—
BU	Air to Water Booster Unit	— (Recommended to manually assign the heat exchanger template (Mnet_WH_vxxx))

**Table 2. VRF model names and factory templates (continued)**

Mitsubishi Electric VRF Model Abbreviation	VRF Model Name	Default Tracer® SC+ Factory Template
FU	Fresh Air Unit or OA Processing Unit	—
IC	MNET Indoor Unit Controller	Mnet_IC_vxxx
IC	LEV (Linear Expansion Valve) kit <sup>(a)</sup>	Mnet_IC_vxxx
IC	S-Series VRF system	Mnet_IC_vxxx (Replace the default assigned template with the template found in HUB DOC-196429)
KIC	K-control indoor unit	—
LC	Lossnay ERV	Mnet_LC_v5xxx
MCp	PI Controller	—
MCT	AI Controller	—
OC	Outdoor Unit	Mnet_OC_vxxx
OC	(Water-Cooled) Outdoor Unit	Mnet_Trane_WOC_vxxx
OS	Outdoor Sub Unit	Mnet_OS_vxxx
RC	Old Remote Controller	—
URC	Universal Remote Controller or Energy Remote Controller	Mnet_URC_v5xxx
WH	Air to Water Heat Exchanger (HEX)	Mnet_WH_vxxx
???	Unknown or device never communicated to Centralized Controller	—

<sup>(a)</sup> VRF without unique model abbreviations - will install with a template based on its model abbreviation. It is recommended that the default template be modified to match the specific VRF equipment.

## Point List

Table 4, p. 44 provides a list of the points for each VRF device when they are auto-installed. Some points may not be present or provide data based on their configuration.

## Communication Status

Communication Status is a point created by Tracer® SC+ for each installed device. Communication status for VRF device will reflect the communication state of the Centralized Controller, NOT the VRF device itself. If a VRF device loses communications, the Centralized Controller will update the Alarm Code and Alarm Message and other points will show the last communicated value.

**Note:** Removing power on VRF device will NOT create a comm loss. The VRF controller may still be powered directly by the MNET link.

## BAS and Arbitration Points

The IDU has controllable points for Occupancy, Setpoint(s), and Mode that are frequently used with Trane applications but can also be controlled by the occupant using a remote controller. In the past, this has created an issue where Tracer® SC+ will “fight” for control with the remote controller.

To help resolve this issue, the VRF integration license will create two points for each of these controllable points: a BAS point and an Arbitration point. The “BAS” point be a BACnet® output object which has a priority array. When the BAS point has its present value changed, it will control the Arbitration point. The arbitration point does not have a priority array and will periodically read the value of the IDU and will only control when its present value changes.

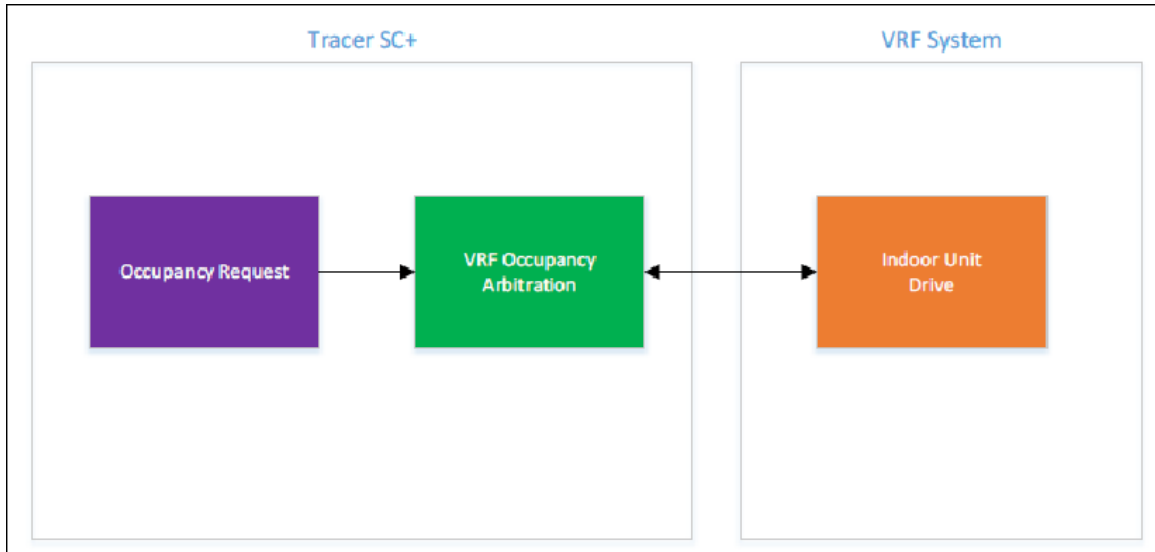
**Figure 36. BAS and arbitration points**

**Table 3. BAS points and corresponding arbitration points**

BAS Point	Arbitration Point
Occupancy Request	VRF Occupancy Arbitration
Heat Cool Mode Request	VRF Heat Cool Mode Arbitration
Occupied Cooling Setpoint BAS	VRF Occupied Cooling Setpoint
Occupied Heating Setpoint BAS	VRF Occupied Heating Setpoint
Unoccupied Cooling Setpoint	VRF Unoccupied Cooling Setpoint
Unoccupied Heating Setpoint	VRF Unoccupied Heating Setpoint
Space Temperature Setpoint BAS	VRF Space Temperature Setpoint

## Indoor Unit (IDU)

**Table 4. Indoor unit (IDU)**

Point Name	Property Name	Point Type	Description
Alarm Code	AlarmCode	AI	This is the VRF alarm code generated by the VRF device. The alarm code is used by the Alarm Message point to provide a text translation of the alarm code. Refer Mitsubishi Electric documentation for more information on specific alarm code.
Alarm Message	—	MSI	This is a text translation of the alarm code. If an alarm code does not have a text translation it will show Unknown. Refer to the alarm code and Mitsubishi Electric documentation for more information on this alarm.
Auto Direction Available	AirAutoSW	BI	IDU support of auto mode for air direction.
Auto Maximum Limit	AutoMax	Writeable-AV	Maximum value for Auto Setpoint.
Auto Minimum Limit	AutoMin	Writeable-AV	Minimum value for Auto Setpoint.
Auto Mode Available	AutoModeSW	BI	IDU support of auto mode.
Auto Mode Type	AutoModeSWEx	MSI	1 = Dual Setpoint 2 = Single Setpoint 3 = Disable

**Table 4. Indoor unit (IDU) (continued)**

Point Name	Property Name	Point Type	Description
Capacity Save Value	Save	AI	Signal of capacity saving from system controller. No signal : 100%.
Centralized Controller Address	—	*	IP Address of Centralized Controller: Port Number.
Controller Address	—	*	MNET address.
Cooling Maximum Limit	CoolMax	Writeable-AV	Maximum value for the Cooling Setpoint.
Cooling Minimum Limit	CoolMin	Writeable-AV	Minimum value for the Cooling Setpoint.
Deadband	Deadband	AI	Minimum deadband between the heating and cooling setpoints and the upper and lower setback setpoints. This value may be changed using Mitsubishi's Maintenance Tool software. Range: 2.7 to 8.1 delta °F Default: 4.5 delta °F It is recommended to lower this default value for most applications.
Dry Mode Available	DryModeSW	BI	IDU support of dry mode.
Error Reset	ErrorSign	Writeable-MSV	This will reset the indoor unit to clear the current error or alarm code. This will only affect the individual IDU not the entire group.
Error Status	ErrorSign	MSI	Indicates if there is an existing error or alarm.
Expansion Valve State	ThermoStatus	BI	State of the expansion valve (open or closed).
Fan Auto Available	FanAutoSW	BI	IDU support auto fan speed mode. <b>Note:</b> If set to disabled, this may be a LEV kit rather than an IDU.
Fan Mode Available	FanModeSW	BI	IDU supports fan mode control. DU supports fan mode control.
Fan Speed	FanSpeed	Writeable-MSV	Shows all possible fan speeds, even if the IDU doesn't support them. The IDU will use the closest speed it supports if an unsupported speed is commanded. 1 = High 2 = Mid 1 3 = Mid 2 4 = Low 5 = Extra Low 6 = Auto 7 = Silent 8 = Stop
Fan Speed Stages Supported	FanSpeedSW	MSI	Fan stages supported by this IDU. None, 2 Stages, 3 Stages, 4 Stages.
Fan Stage	FAN	MSI	If the fan is running, this is the fan stage the fan will control use.
Fan Status	FanStatus	BI	Fan On/Off status.
Filter Reset	FilterSign	MSO	Only control this point to Resetting to reset the dirty filter alarm. Use Filter status for current filter status.
Filter Status	FilterSign	MSI	OFF (0) - Clean. ON (1) - Dirty. RESET (2) - Resetting.
Free Input 1	FC3	BI	Status of terminal CN32-2.
Free Input 2	FC4	BI	Status of terminal CN32-3.
Free Input 3	FC5	BI	Status of terminal CN51-2.
Free Input 4	FC6	BI	Status of terminal CN32-2.
Free Output 1 Command	FC0	Writeable-BV	Read/write of terminal CN52-2.

**Table 4. Indoor unit (IDU) (continued)**

Point Name	Property Name	Point Type	Description
Free Output 2 Command	FC1	Writeable-BV	Read/write of terminal CN52-3.
Free Output 3 Command	FC2	Writeable-BV	Read/write of terminal CN52-4.
Gas Line Temperature (TH3)	TH3	AI	Detects the gas side temperature of indoor unit for control sensor error and SH control.
Group	—	*	Group number.
Group Generation	Group Type	MSI	Generation of IDU group member (New or Old).
Heat Cool Mode Request	Mode (Group data)	MSO	Standard Heat Cool Mode Request key used by some Trane applications. This point will push its value to the VRF Heat Cool Mode Arbitration point which will then affect the IDU Mode.
Heat Cool Mode Status	Mode (Group data)	MSI	Standard Heat Cool Mode Status key used by some Trane applications and graphics.
Heating Maximum Limit	HeatMax	Writeable-AV	Maximum value of the heating setpoint.
Heating Minimum Limit	HeatMin	Writeable-AV	Minimum value of the heating setpoint.
Indoor Coil Status (ICS)	ICS	MSI	Mode and Status of the IDU coil: (1) = Unknown (2) = Cool ON (3) = Cool OFF (4) = Heat ON (5) = Heat OFF (6) = Stop
Indoor LEV Step Position (Li)	Li	AI	The linear expansion valve step position. 41 = 0% (closed). 2000 = 100% (open).
Liquid Line Temperature (TH2)	TH2	AI	Detects the liquid side temperature of indoor unit for frost prevention and SH/SC control.
Lockout Control Available	ProhibitSW	BI	Configuration parameter defining if the IDU allows the BAS to lockout local control functions using the remote controller.
Lockout Local Fan Speed Control	FanSpeedItem	Writeable-BV	Locks out local Fan Speed control at the remote controller.
Lockout Local Filter Reset	FilterItem	Writeable-BV	Locks out local filter reset control at the remote controller.
Lockout Local Mode Control	ModeItem	Writeable-BV	Locks out local Mode control at the remote controller.
Lockout Local ON OFF Control	DriveItem	Writeable-BV	Locks out local ON/OFF control at the remote controller.
Lockout Local Setpoint Control	SetTempItem	Writeable-BV	Locks out local setpoint control at the remote controller.
Lockout Local Timer Control	TimerItem	Writeable-BV	Locks out local Timer control at the remote controller.
Lockout Local Vane Direction Control	AirDirItem	Writeable-BV	Locks out local Vane Direction control at the remote controller.
Lockout Status	RemoCon	Writeable-BV	This point is not recommended to be used. If all lockouts are active, this point will be Locked. If all lockouts are not active, this point will be unlocked. If the lockout points are in a mixed state, this point will remain at its last value. This point can be written, but will only affect the state of this point if the other lockout points are in a mixed state.
Maximum Save Value	MaxSaveValue	Writeable-AV	Sets the maximum save value%. 0% = Thermo OFF. This limit can be cancelled at the IDU which will change the Maximum Save Value to 100%. Default = 100%.
Model Name	—	*	Mitsubishi Electric Model name. IC for an IDU.
Model Number	—	*	Mitsubishi Electric Model number. F/P for an IDU.

**Table 4. Indoor unit (IDU) (continued)**

Point Name	Property Name	Point Type	Description
Occupancy Request	State	MSO	Factory created to control VRF Occupancy Arbitration which controls the IDU state.
Occupancy Status	State (Maintenance Data)	MSI	Standard occupancy status key.
Occupied Cooling Setpoint BAS	SetTemp1	AO	Factory created to control VRF Occupied Cooling Setpoint.
Occupied Heating Setpoint BAS	SetTemp2	AO	Factory created to control VRF Occupied Heating Setpoint.
Occupied Cooling Setpoint	SetTemp1	AI	Standard Occupied Cooling Setpoint key.
Occupied Heating Setpoint	SetTemp2	AI	Standard Occupied Heating Setpoint key.
On Off Status	ON OFF	*	On Off Status of the IDU. Typical states are Operating or Stopping.
Outdoor Controller Address	—	*	Address of the System Main Outdoor Unit.
Remote Controller (Main) Address	—	*	Address of Remote Controller This will be blank if there isn't a remote controller in the same group.
Remote Controller (Sub) Address	—	*	Address of Sub-Remote Controller This will be blank if there isn't a sub-remote controller in the same group.
Secondary Heat State	SubHeaterStatus	BI	On/Off status of the secondary heat.
Setback Mode Available	SetbackModeSW	BI	IDU support of setback mode.
Space Temperature (TH1)	TH1	AI	Onboard thermistor sensor for space temperature.
Space Temperature Compatibility	—	BI	Read-only point that indicates if the IDU will allow Tracer® SC+ to write to its Space Temperature BAS point via Air-Fi® communications.
Space Temperature Enabled	—	BI	Read-only point that indicates if Tracer® SC+ has been setup to use an Air-Fi® sensor to write to Space Temperature Setpoint BAS. Any changes to Space Temperature BAS will write to the space temperature of the IDU.
Space Temperature Active	InletTemp	AI	The space temperature used by the IDU. This defaults to the same value as TH1 but may be configured at the IDU to use the space temperature sensor at the remote controller.
Space Temperature Setpoint Active	TO	AI	Target space temperature setpoint.
Space Temperature BAS	—	AO	This point will send the space temperature value from an Air-Fi sensor to an IDU. <b>Note:</b> This point will only appear if Space Temperature Compatibility is Yes and Space Temperature Enabled is Enabled.
Space Temperature Setpoint BAS	SetTemp	AO	Only used on IDUs using a single setpoint.
Subcool (SC)	SC	AI	Valid in heating mode.
Superheat (SH)	SH	AI	Valid in cooling mode.
Swing Available	SwingSW	BI	IDU support of swing mode for vane direction.
TH4	TH4	AI	Typically not used for IDUs. TH4 can be used for different sensor values depending on the equipment type. Refer to Mitsubishi Electric equipment documentation for specific naming information for this point.
Unoccupied Cooling Setpoint	SetTemp4	AO	The Unoccupied Cooling Setpoint is used when the IDU is in Setback Mode.
Unoccupied Heating Setpoint	SetTemp5	AO	The Unoccupied Heating Setpoint is used when the IDU is in Setback Mode. See VRF Heat Cool Mode Arbitration for Setback mode.

**Appendix**
**Table 4. Indoor unit (IDU) (continued)**

Point Name	Property Name	Point Type	Description
Vane Control Available	AirDirectionSW	BI	IDU support of vane control.
Vane Direction	AirDirection	Writeable-MSV	Read/write the IDU vane direction. (1) - Horizontal (0%) (2) - Downblow (20%) (3) - Downblow (40%) (4) - Downblow (60%) (5) - Vertical (90%) (6) - Swing (7) - Auto
Vane Direction Stages Supported	AirStageSW	MSI	Number of vane direction stages supported <ul style="list-style-type: none"> <li>• 4 Stages</li> <li>• 5 Stages</li> </ul>
VRF Heat Cool Mode Arbitration	Mode (Group data)	Writeable-MSV	Read.write heat cool mode of the IDU. <b>Note:</b> This is a list of heat cool modes for all products. Not all modes will apply to specific equipment. 1 = Auto 2 = Heating 3 = Dry Mode 4 = Cooling 5 = Auto (Heating) 6 = Auto (Cooling) 7 = Setback 8 = Setback (Heating) 9 = Setback (Cooling) 10 = Fan Only 11 = Heat Recovery 12 = Auto 13 = Bypass 14 = Warm Water 15 = Warm Water (Eco) 16 = Hot Water 17 = Freeze Prevention 18 = Cooled Water
VRF Heat Cool Mode Status	Mode (Maintenance data)	MSI	1 = Auto 2 = Heating 3 = Dry Mode 4 = Cooling 5 = Auto (Heating) 6 = Auto (Cooling) 7 = Setback 8 = Setback (Heating) 9 = Setback (Cooling) 10 = Fan Only
VRF Occupancy Arbitration	Drive	Writeable-MSV	1 = Occupied 2 = Unoccupied 3 = Test Run
VRF Occupied Cooling Setpoint	SetTemp1	Writeable-AV	Read/write point for occupied cooling setpoint. This point is only valid for dual setpoint devices.
VRF Occupied Heating Setpoint	SetTemp2	Writeable-AV	Read/write point for occupied heating setpoint. This point is only valid for dual setpoint devices.
VRF Space Temperature Setpoint	SetTemp	Writeable-AV	Read/write point for occupied setpoint. This point is only valid for single setpoint devices.
VRF Unoccupied Cooling Setpoint	SetTemp5	Writeable-AV	Read/write point for Unoccupied Cooling Setpoint.
VRF Unoccupied Heating Setpoint	SetTemp5	Writeable-AV	Read/write point for Unoccupied Heating Setpoint.

**Note:** \* = non-interoperable point for third-party BACnet® systems.

## Outdoor Unit (ODU) – Air Cooled

**Table 5. Outdoor Unit (ODU) water cooled**

Point Name	Property Name	Point Type
Active Demand Limit Setpoint	Save(%)	AI
ACC Inlet Pipe Temperature (TH5)	TH5	AI
Bypass Inlet Temperature (TH15)	TH15	AI
Bypass Outlet Temperature (TH12)	TH12	AI
Capacity Saving Mode	DEMAND2	BI
Compressor Discharge Temperature (TH4)	TH4	AI
Compressor Frequency Combined	F (Hz)	AI
Compressor Frequency of Main	Foc (Hz)	AI
Compressor Phase U Current	Iu	AI
Compressor Phase W Current	Iw	AI
Compressor Rotation Timer	Rotation timer	AI
Compressor Operation Status	Open Status	MSI
Control Mode Status	Ctrl Mode	MSI
Demand	DEMAND	BI
Discharge Suction Bypass (SV1a)	SV1A	BI
Efficiency	COP	AI
Energy	MeterValue	AI
Entering Water Temperature (TH7)	TH7	AI
Frequency	F	AI
Fan Inverter Firmware	FAN-Ver	*
Fan Output	% Fan	AI
Freeze Protection Sensor (TH9)	TH9	AI
High Side Saturation Temperature (Tc)	Tc	AI
Inverter Bus Voltage	Vdc	AI
Inverter Temperature	THINV	AI
Inverter Heat Sink Temperature	THHS	AI
Inverter LEV Step Position	LEVINV	AI
Line Frequency	F	AI
Liquid Inlet Temperature (TH11)	TH11	AI
Liquid Refrigerant Temperature (TH16)	TH16	AI
Low Side Saturation Temperature (Te)	Te	AI
Low Ambient Capacity Control (LEV5a)	LEV5a	AI
Leaving Water Temperature (TH8)	TH8	AI
Location Label	—	*
LEV6	LEV6	AI
LEV7	LEV7	AI

**Appendix**
**Table 5. Outdoor Unit (ODU) water cooled (continued)**

Point Name	Property Name	Point Type
Measurement Data Status	Measurement	AI
Night Mode	NightMode	BI
Operational Mode Status	Open Mode	MSI
Outdoor Unit Fan State	FAN -Free	MSI
Outdoor Unit Silent Mode1	NIGHT	BI
Outdoor Unit Silent Mode2	NIGHT2	BI
Outdoor Unit StartUp	Start-up unit	MSI
Power	Power	AI
Profile Name	—	*
Refrigerant High Side Pressure (63HS1)	63HS1	AI
Refrigerant Low Side Pressure (63LS)	63LS	AI
Reversing Valve Position (21S4a)	21S4A	BI
Snow Sensor	SNOW	BI
Solenoid Valve Port 4A	SV4A	BI
Solenoid Valve Port 4B	SV4B	BI
Solenoid Valve Port 4D	SV4D	BI
Solenoid Valve Port 5B	SV5B	BI
Solenoid Valve Port 7A	SV7A	BI
Solenoid Valve Port 7B	SV7B	BI
Subcool at SubCool Coil Exit	SCc	AI
Subcool at Heat Exchanger	SCo	AI
Superheat at SubCool Coil Bypass Exit	SHb	AI
Software Application Version	—	*
Subcool Coil LEV Step Position	LEV1	AI
Subcooled Liquid Refrigerant Temperature (TH6)	TH6	AI
Subcool bypass outlet temperature (TH2)	TH2	AI
SV9	SV9	BI
Total Cooling Capacity	QjC	AI
Total Heating Capacity	QjH	AI
TH3	TH3	AI
Unit On/Off	UnitOnOff	BI
Vendor Name	—	*

**Note:** \* = non-interoperable point for third-party BACnet® systems.

**Table 6. Outdoor Unit (ODU) air cooled**

Point Name	Property Name	Point Type	Description
Accumulator Level	ALh	MSI	Liquid level in accumulator: 1=Unknown 2=Low 3=Middle 4=High
Active Demand Limit Setpoint	Save(%)	AI	Capacity limit based on: DEMAND=OFF, DEMAND2=OFF: 100%. DEMAND=OFF, DEMAND2=ON: 75%. DEMAND= ON, DEMAND2=ON: 50%. DEMAND= ON, DEMAND2=OFF: 25%.
Alarm Code	AlarmCode	AI	This is the VRF alarm code generated by the VRF device. The alarm code is used by the Alarm Message point to provide a text translation of the alarm code. Refer Mitsubishi Electric documentation for more information on specific alarm code.
Alarm Message	—	MSI	This is a text translation of the alarm code. If an alarm code does not have a text translation it will show Unknown. Refer to the alarm code and Mitsubishi Electric documentation for more information on this alarm.
Capacity Saving Mode	Demand2	BI	Input used to limit compressor operation and calculate <i>Active Demand Limit Setpoint</i> .
Centralized Controller Address	—	*	IP Address of Centralized Controller: Port Number.
Compressor Discharge Temperature (TH4)	TH4	AI	TH4 thermistor.
Compressor Frequency Combined	F (Hz)	AI	Compressor frequency of the main and sub ODUs added together.
Compressor Frequency of Main	Foc (Hz)	AI	Compressor frequency of the Main ODU.
Compressor Frequency of Sub	Fos (Hz)	AI	Compressor frequency of the Sub ODU.
Compressor Operation Status	Ope Status	MSI	1=Unknown 2=Abnormal Pressure Rise 3=Stop 4=Abnormal Pressure Drop 5=High Pressure Drop 6=Normal
Compressor Phase U Current	Iu	AI	Also called Phase A or L1 current.
Compressor Phase W Current	Iw	AI	Also called Phase B or L2 current.
Compressor Rotation Timer	Rotation timer	AI	Compressor run time in hours.
Compressor Sump Temperature (TH15)	TH15	AI	TH15 thermistor.
Control Mode Status	Ctrl Mode	MSI	ODU control mode: 1=Unknown 2=Ordinary 3=Oil Recovery 4=OFF 5=Defrost 6=Initial 7=Error 8=Refrigerant Recovery 9=Stop
Controller Address	—	*	MNET address.
Demand	Demand	BI	Input used to limit compressor operation and calculate <i>Active Demand Limit Setpoint</i> .
Discharge Suction Bypass (SV1a)	SV1a	BI	Solenoid valve SV1a Open/Close.

## Appendix

**Table 6. Outdoor Unit (ODU) air cooled (continued)**

Point Name	Property Name	Point Type	Description
Efficiency	COP	AI	Requires Mitsubishi Electric Energy Management License or the value show —.
Energy	MeterValue	AI	Requires Mitsubishi Electric Energy Management License or the value show —.
Fan (rpm)	FAN (rpm)	AI	Fan 1 rotation per minute.
Fan 2 (rpm)	FAN 2 (rpm)	AI	Fan 2 rotation per minute.
Fan 2 Output %	FAN2	AI	Fan 2 output %.
Fan Inverter Firmware	Fan -Ver	AI	Firmware version of the inverter.
Fan Output %	FAN	AI	Fan 1 output %.
High Side Saturation Temperature (Tc)	Tc	AI	High Side Saturation Temperature.
IH Bound Power	IH	BI	0= Stop 1=Run
Inverter Bus Voltage	Vdc	AI	Inverter Bus Voltage.
Inverter DC Current	Idc	AI	Inverter DC Current.
Inverter Heat Sink Temperature	THHS	AI	Inverter Heat Sink Temperature.
Line Frequency	F (Measurement Data)	AI	Compressor Frequency.
Low Ambient Capacity Control (LEV5a)	LEV5a	AI	LEV5a pulse rate. 41=0%. Varies by ODU model = 100%.
Low Side Saturation Temperature (Te)	Te	AI	Low Side Saturation Temperature.
Measurement Data Status	Measurement	BI	Energy Management License is enabled/disabled. This must be enabled for most Measurement data (Energy, Efficiency, and Power).
Model Name	—	*	Mitsubishi Electric Model name. OC or OS for an ODU.
Model Number	—	*	Mitsubishi Electric Model number.
Night Mode	NightMode	BI	Unit is in night mode. See <i>Outdoor Unit Silent Mode1</i> and <i>Outdoor Unit Silent Mode2</i> .
Operational Mode Status	Ope Mode	MSI	Operational mode of the ODU. Cooling main and heating main means the ODU is primarily cooling or heating respectively (for energy recovery systems). 1=Unknown 2=Cooling Only 3=Heating Only 4=Cooling Main 5=Heating Main 6=Stop 7=Heating 8=Cooling
Outdoor Air Temperature	TH7	AI	Outdoor Air Temperature.
Outdoor Controller Address	—	*	Address of the System Main Outdoor Unit.
Outdoor Unit Fan 2 State	Fan2-Free	MSI	On/Off status of Fan 2.
Outdoor Unit Fan State	Fan -Free	MSI	On/Off status of Fan 1.
Outdoor Unit Silent Mode1	Night	BI	If enabled, the ODU will decrease the compressor frequency at night for quieter operation. Prioritize capacity over quiet.

**Table 6. Outdoor Unit (ODU) air cooled (continued)**

Point Name	Property Name	Point Type	Description
Outdoor Unit Silent Mode2	Night2	BI	If enabled, the ODU will decrease the compressor frequency at night for quieter operation. Prioritize quiet over capacity.
Outdoor Unit StartUp	Start-up unit	MSI	Only the startup unit will have Line Frequency and Outdoor Unit Frequency. 1=Unknown 2=OC 3=OS
Power	Power	AI	Requires Mitsubishi Electric Energy Management License or the value show —.
Refrigerant High Side Pressure (63HS1)	63HS1	AI	Refrigerant High Side Pressure.
Refrigerant Low Side Pressure (63LS)	63LS	AI	Refrigerant Low Side Pressure.
Reversing Valve Position (21S4a)	21S4a	BI	Solenoid Valve 21S4a . 0=Cooling 1=Heating
Reversing Valve Position (21S4b)	21S4b	BI	Solenoid Valve 21S4b . 0=Cooling 1=Heating
Snow Sensor	Snow	BI	Snow sensor indicates snow on the ODU fan. ODU will turn on fan to remove snow.
Solenoid Valve Port 4A	SV4a	BI	Solenoid valve port 4A (Open/Close).
Solenoid Valve Port 4B	SV4b	BI	Solenoid valve port 4B (Open/Close).
Solenoid Valve Port 4D	SV4d	BI	Solenoid valve port 4D (Open/Close).
Solenoid Valve Port 5B	SV5b	BI	Solenoid valve port 5B (Open/Close).
Suction Line Temperature (TH5)	TH5	AI	TH5 thermistor.
SV9	SV9	BI	Solenoid valve SV9 (Open/Close).
TH3	TH3	AI	TH3 thermistor.
TH6	TH6	AI	TH6 thermistor.

Note: \* = non-interoperable point for third-party BACnet® systems.

## Branch Controller (BC)

**Table 7. Branch controller (BC)**

Point Name	Property Name	Point Type	Description
Alarm Code	AlarmCode	AI	This is the VRF alarm code generated by the VRF device. The alarm code is used by the Alarm Message point to provide a text translation of the alarm code. Refer Mitsubishi Electric documentation for more information on specific alarm code.
Alarm Message	—	MSI	This is a text translation of the alarm code. If an alarm code does not have a text translation it will show Unknown. Refer to the alarm code and Mitsubishi Electric documentation for more information on this alarm.
Centralized Controller Address	—	*	IP Address of Centralized Controller: Port Number.
Controller Address	—	*	MNET address.
Differential Pressure (PS1 - PS3)	dPHM	AI	Differential pressure between PS1 and PS3 pressure sensors.

**Appendix**
**Table 7. Branch controller (BC) (continued)**

Point Name	Property Name	Point Type	Description
High Pressure Sensor (P1)	P1	AI	High Pressure Sensor (P1).
Indoor Unit Operation	OC Sig	MSI	Main ODU signal for Indoor unit operation. 1=Unknown 2=Cooling Only 3=Heating Only 4=Enable 5=StandBy 6=Refrigerant Conversion Cooling Only 7=Refrigerant Conversion Heating Only 8=Mainly Heating 9=Mainly Cooling
Intermediate Pressure Sensor (PS3)	PS3	AI	Intermediate Pressure Sensor (PS3).
Intermediate Temp of PS3	PT3	AI	Intermediate Temp of PS3.
LEV 1 Position	L1	AI	LEV1 pulse rate. 41=0%. Varies by BC model = 100%.
LEV 2 Position	L2	AI	LEV2 pulse rate. 41=0%. Varies by BC model = 100%.
LEV 3 Position	L3	AI	LEV3 pulse rate. 41=0%. Varies by BC model = 100%.
Model Name	—	*	Mitsubishi Electric Model name. BC or BS for a Branch Controller.
Model Number	—	*	Mitsubishi Electric Model number.
Outdoor Controller Address	—	*	Address of the System Main Outdoor Unit.
Outdoor Unit Operation	BC Sig	MSI	ODU operation. 1=Unknown 2=Cooling Only On 3=Heating Only On 4=Stop 5=Cooling Only Off 6=Heating Only Off
Primary Subcooling	SC1	AI	Primary Subcooling.
Saturation Temperature of PS1	PT1	AI	Saturation Temperature of PS1.
Secondary Subcooling	SC6	AI	Secondary Subcooling.
Solenoid Valve Port 10A	SV10a	BI	Open/Closed.
Solenoid Valve Port 10B	SV10b	BI	Open/Closed.
Solenoid Valve Port 10C	SV10c	BI	Open/Closed.
Solenoid Valve Port 11A	SV11a	BI	Open/Closed.
Solenoid Valve Port 11B	SV11b	BI	Open/Closed.
Solenoid Valve Port 11C	SV11c	BI	Open/Closed.
Solenoid Valve Port 12A	SV12a	BI	Open/Closed.
Solenoid Valve Port 12B	SV12b	BI	Open/Closed.
Solenoid Valve Port 12C	SV12c	BI	Open/Closed.
Solenoid Valve Port 13A	SV13a	BI	Open/Closed.
Solenoid Valve Port 13B	SV13b	BI	Open/Closed.

**Table 7. Branch controller (BC) (continued)**

Point Name	Property Name	Point Type	Description
Solenoid Valve Port 13C	SV13c	BI	Open/Closed.
Solenoid Valve Port 14A	SV14a	BI	Open/Closed.
Solenoid Valve Port 14B	SV14b	BI	Open/Closed.
Solenoid Valve Port 14C	SV14c	BI	Open/Closed.
Solenoid Valve Port 15A	SV15a	BI	Open/Closed.
Solenoid Valve Port 15B	SV15b	BI	Open/Closed.
Solenoid Valve Port 15C	SV15c	BI	Open/Closed.
Solenoid Valve Port 16A	SV16a	BI	Open/Closed.
Solenoid Valve Port 16B	SV16b	BI	Open/Closed.
Solenoid Valve Port 16C	SV16c	BI	Open/Closed.
Solenoid Valve Port 1A	SV1a	BI	Open/Closed.
Solenoid Valve Port 1B	SV1b	BI	Open/Closed.
Solenoid Valve Port 1C	SV1c	BI	Open/Closed.
Solenoid Valve Port 2A	SV2a	BI	Open/Closed.
Solenoid Valve Port 2B	SV2b	BI	Open/Closed.
Solenoid Valve Port 2C	SV2c	BI	Open/Closed.
Solenoid Valve Port 3A	SV3a	BI	Open/Closed.
Solenoid Valve Port 3B	SV3b	BI	Open/Closed.
Solenoid Valve Port 3C	SV3c	BI	Open/Closed.
Solenoid Valve Port 4A	SV4a	BI	Open/Closed.
Solenoid Valve Port 4B	SV4b	BI	Open/Closed.
Solenoid Valve Port 4C	SV4c	BI	Open/Closed.
Solenoid Valve Port 4D	SV4d	BI	Open/Closed.
Solenoid Valve Port 5A	SV5a	BI	Open/Closed.
Solenoid Valve Port 5B	SV5b	BI	Open/Closed.
Solenoid Valve Port 5C	SV5c	BI	Open/Closed.
Solenoid Valve Port 6A	SV6a	BI	Open/Closed.
Solenoid Valve Port 6B	SV6b	BI	Open/Closed.
Solenoid Valve Port 6C	SV6c	BI	Open/Closed.
Solenoid Valve Port 7A	SV7a	BI	Open/Closed.
Solenoid Valve Port 7B	SV7b	BI	Open/Closed.
Solenoid Valve Port 7C	SV7c	BI	Open/Closed.
Solenoid Valve Port 8A	SV8a	BI	Open/Closed.
Solenoid Valve Port 8B	SV8b	BI	Open/Closed.
Solenoid Valve Port 8C	SV8c	BI	Open/Closed.
Solenoid Valve Port 9A	SV9a	BI	Open/Closed.
Solenoid Valve Port 9B	SV9b	BI	Open/Closed.



## Appendix

**Table 7. Branch controller (BC) (continued)**

Point Name	Property Name	Point Type	Description
Solenoid Valve Port 9C	SV9c	BI	Open/Closed.
Superheat in the BC Controller	SH2	AI	Superheat in the BC Controller.
SVM	SVM	BI	Only used with a single BC (no subs). Open/Closed.
TH11	TH11	AI	TH11 Thermistor.
TH12	TH12	AI	TH12 Thermistor.

**Note:** \* = non-interoperable point for third-party BACnet® systems.

## Remote Controller

**Table 8. Remote controller**

Point Name	Property Name	Point Type	Description
Alarm Code	AlarmCode	AI	This is the VRF alarm code generated by the VRF device. The alarm code is used by the Alarm Message point to provide a text translation of the alarm code. Refer Mitsubishi Electric documentation for more information on specific alarm code.
Alarm Message	—	MSI	This is a text translation of the alarm code. If an alarm code does not have a text translation it will show Unknown. Refer to the alarm code and Mitsubishi Electric documentation for more information on this alarm.
Centralized Controller Address	—	*	IP Address of Centralized Controller: Port Number.
Controller Address	—	*	MNET address.
Group	—	*	Group number.
Model Name	—	*	Mitsubishi Electric Model name. URC for a Remote Controller.
Model Number	—	*	Mitsubishi Electric Model number. — for a Remote Controller.
Occupancy Input	Occupancy	BI	Occupancy Sensor (Occupied/Unoccupied).
Outdoor Controller Address	—	*	Address of the System Main Outdoor Unit.
Room Brightness	Brightness	BI	Light sensor (Bright/Dark).
Space Humidity Local	RoomHumidity	AI	Humidity (%).
Space Temperature Local	RoomTemp	AI	Temperature (Thermistor).

**Note:** \* = non-interoperable point for third-party BACnet® systems.

## Lossnay

**Table 9. Lossnay**

Point Name	Property Name	Point Type	Description
Alarm Code	AlarmCode	AI	This is the VRF alarm code generated by the VRF device. The alarm code is used by the Alarm Message point to provide a text translation of the alarm code. Refer Mitsubishi Electric documentation for more information on specific alarm code.
Alarm Message	—	MSI	This is a text translation of the alarm code. If an alarm code does not have a text translation it will show Unknown. Refer to the alarm code and Mitsubishi Electric documentation for more information on this alarm.
Average IDU Setpoint for Auto Ventilation	TO	AI	Average Setpoint of connected IDUs when ventilation mode is auto.

**Table 9. Lossnay (continued)**

Point Name	Property Name	Point Type	Description
Centralized Controller Address	—	*	IP Address of Centralized Controller: Port Number.
Controller Address	—	*	MNET address.
Error Reset	ErrorSign	Writeable -MSV	This will reset the indoor unit to clear the current error or alarm code. This will only affect the individual IDU not the entire group.
Error Status	ErrorSign	MSI	Indicates if there is an existing error or alarm.
ERV Exhaust Fan Command Status	EA ordered	MSI	1=Stopping 2=Stopping Low 3=Low 4=High 5=Extra High
ERV Exhaust Fan State	EA	MSI	On/Off.
ERV Outdoor Air Temperature	OA Temp.	AI	ERV Outdoor Air Temperature.
ERV Space Temperature Active	RA Temp.	AI	ERV Space Temperature .
ERV Supply Fan Command Status	SA ordered	MSI	1=Stopping 2=Stopping Low 3=Low 4=High 5=Extra High
ERV Supply Fan State	SA	MSI	On/Off.
ERV Ventilation Mode	Mode	MSI	1=Normal 2=Night Purge 3=24hr Operation
Fan Speed	FanSpeed	Writeable-MSV	Shows all possible fan speeds, even if the IDU doesn't support them. The IDU will use the closest speed it supports if an unsupported speed is commanded. 1 = High 2 = Mid 1 3 = Mid 2 4 = Low 5 = Extra Low 6 = Auto 7 = Silent 8 = Stop
Fan Status	FanStatus (Unit Operation)	BI	On/Off.
Group	—	*	Group number.
Heat Cool Mode Request	Mode	MSO	Standard Heat Cool Mode Request key used by some Trane applications. This point will push its value to the VRF Heat Cool Mode Arbitration point which will then affect the Lossnay Mode.
Lockout Local Fan Speed Control	FanSpeedItem	Writeable-BV	Locks out local Fan Speed control at the remote controller.
Lockout Local Mode Control	ModelItem	Writeable-BV	Locks out local Mode control at the remote controller.
Lockout Local ON OFF Control	Driveltem	Writeable-BV	Locks out local On/Off control at the remote controller.
Lockout Status	RemoCon	Writeable-BV	This point is not recommended to be used. If all lockouts are active, this point will be Locked. If all lockouts are not active, this point will be unlocked. If the lockout points are in a mixed state, this point will remain at its last value. This point can be written, but will only affect the state of this point if the other lockout points are in a mixed state.
Model Name	—	*	Mitsubishi Electric Model name. LC for a Lossnay.

## Appendix

**Table 9. Lossnay (continued)**

Point Name	Property Name	Point Type	Description
Model Number	—	*	Mitsubishi Electric Model number. F/P for a Lossnay.
Occupancy Request	Drive	MSO	Factory created to control VRF Occupancy Arbitration which controls the IDU state.
On/Off Operating Mode	O/F	MSI	1=Unknown 2=Stopping 3=Operating 4=Interlocked Operation 5=Delayed Operation 6=Error
Outdoor Controller Address	—	*	Address of the System Main Outdoor Unit.
Remote Controller (Main) Address	—	*	Address of Remote Controller. This will be blank if there isn't a remote controller in the same group.
Remote Controller (Sub) Address	—	*	Address of Sub-Remote Controller. This will be blank if there isn't a sub-remote controller in the same group.
Space Temperature Setpoint BAS	SetTemp	AO	Only used when using a single setpoint.
VRF Heat Cool Mode Arbitration	Mode (Group data)	Writeable-MSV	Read/write heat cool mode of the IDU. <b>Note:</b> <i>This is a list of heat cool modes for all products. Not all modes will apply to specific equipment.</i> 1 = Auto 2 = Heating 3 = Dry Mode 4 = Cooling 5 = Auto (Heating) 6 = Auto (Cooling) 7 = Setback 8 = Setback (Heating) 9 = Setback (Cooling) 10 = Fan Only 11 = Heat Recovery 12 = Auto 13 = Bypass 14 = Warm Water 15 = Warm Water (Eco) 16 = Hot Water 17 = Freeze Prevention 18 = Cooled Water
VRF Occupancy Arbitration	Drive	Writeable-MSV	1 = Occupied 2 = Unoccupied 3 = Test Run
VRF Space Temperature Setpoint	SetTemp	Writeable-AV	Read/write the occupied setpoint. This point is only valid for single setpoint devices.

**Note:** \* = non-interoperable point for third-party BACnet® systems.

**Note:** *The VRF system can lockout specific IDU remote controller functions such are ON/OFF, Set Temperature, etc. Changing lockout status at the Centralized Controller or at Tracer SC+ requires the IDU to be ON. If the IDU is OFF, the lockout status will NOT be updated*

## Heat Exchanger (HEX)

Table 10. Heat exchanger (HEX)

Point Name	Property Name	Point Type	Description
Alarm Code	AlarmCode	AI	This is the VRF alarm code generated by the VRF device. The alarm code is used by the Alarm Message point to provide a text translation of the alarm code. Refer Mitsubishi Electric documentation for more information on specific alarm code.
Alarm Message	AlarmCode	MSI	This is a text translation of the alarm code. If an alarm code does not have a text translation it will show Unknown. Refer to the alarm code and Mitsubishi Electric documentation for more information on this alarm.
Booster Unit LEV 1 Pulse Rate	LEV1W	AI	Linear expansion valve pulse rate. 41 = 0%. 2000 = 100%.
Booster Unit LEV 2 Pulse Rate	LEV2W	AI	Linear expansion valve pulse rate. 41 = 0%. 2000 = 100%.
Centralized Controller Address	—	*	IP Address of Centralized Controller: Port Number.
Compressor Phase U Current	Iu	AI	Also called Phase A or L1 current.
Compressor Stop Input	DEMAND	BI	Input used to limit compressor operation.
Controller Address	—	*	MNET Address.
Discharge Air Temperature	TH11	AI	Discharge temperature (TH11).
Error Reset	ErrorSign	Writeable-MSV	This will reset the indoor unit to clear the current error or alarm code. This will only affect the individual IDU not the entire group.
Error Status	ErrorSign	MSI	Indicates if there is an existing error or alarm.
Evaporator Outlet Temperature (TH13)	TH13	AI	Water Outlet temperature.
Expansion Valve State	ThermoStatus	BI	Expansion valve state (Open/Closed).
Gas Line Temperature (TH23)	TH23	AI	TH23 Thermistor.
Group	—	*	Group number.
Heat Cool Mode Request	Mode	MSO	Standard Heat Cool Mode Request key used by some Trane applications. This point will push its value to the VRF Heat Cool Mode Arbitration point which will then affect the HEX Mode.
HEX Operational Mode Status	Ope Mode	MSI	1=Unknown 2=Ordinary 3=Oil Recovery 4=OFF 5=Defrost 6=Initial 7=Error 8=Refrigerant Recovery 9=Stop
HEX Reference Temperature (TH4)	TH4	AI	TH4 Thermistor.
High Pressure Sensor (63HSW)	63HSW	AI	High Pressure Sensor (63HSW).
Inverter Bus Voltage	Vdc	AI	Compressor bus voltage.
Inverter Heat Sink Temperature	THHS	AI	Heat sink temperature (THHS).
Liquid Side Temperature (TH22)	TH22	AI	TH22 thermistor. Detects the liquid side temperature for frost prevention and SH/SC control.

**Appendix**
**Table 10. Heat exchanger (HEX) (continued)**

Point Name	Property Name	Point Type	Description
Lockout Local Mode Control	ModelItem	Writeable-BV	Locks out local Mode control at the remote controller.
Lockout Local ON OFF Control	DriveItem	Writeable-BV	Locks out local On/Off control at the remote controller.
Lockout Local Setpoint Control	SetTempItem	Writeable-BV	Locks out local setpoint control at the remote controller.
Lockout Status	RemoCon	Writeable-BV	This point is not recommended to be used. If all lockouts are active, this point will be Locked. If all lockouts are not active, this point will be unlocked. If the lockout points are in a mixed state, this point will remain at its last value. This point can be written, but will only affect the state of this point if the other lockout points are in a mixed state.
Low Pressure Sensor (63LSW)	63LSW	AI	Low Pressure Sensor (63LSW).
Model Name	—	*	Mitsubishi Electric Model name. WH for a HEX.
Model Number	—	*	Mitsubishi Electric Model number.
Occupancy Request	State	MSO	Factory created to control VRF Occupancy Arbitration which controls the IDU state.
On/Off Operating Mode	O/F	MSI	Operation running of Water HEX Unit 1=Unknown 2=Stopping 3=Operating 4=Interlocked Operation 5=Delayed Operation 6=Error
Outdoor Controller Address	—	*	Address of the System Main Outdoor Unit.
Outdoor Unit Control Mode Status	Ctrl Mode	MSI	Water HEX Unit control mode.
Reset Diagnostic	ErrorSign	Writeable-BV	
Solenoid Valve Bypass (SV1)	SV1	BI	Bypass between gas pipe and liquid pipe (Open/Closed).
Space Temperature Setpoint BAS	SetTemp	AO	Only used on IDUs using a single setpoint.
Subcool (SC)	SC	AI	Subcool.
Superheat (SH)	SH	AI	Superheat.
System Compressor Frequency	F	AI	Temporary compressor frequency for calculation.
VRF Heat Cool Mode Arbitration	Mode (Group data)	Writeable-MSV	Read.write heat cool mode of the IDU. <b>Note:</b> This is a list of heat cool modes for all products. Not all modes will apply to specific equipment. 1 = Auto 2 = Heating 3 = Dry Mode 4 = Cooling 5 = Auto (Heating) 6 = Auto (Cooling) 7 = Setback 8 = Setback (Heating) 9 = Setback (Cooling) 10 = Fan Only 11 = Heat Recovery 12 = Auto 13 = Bypass 14 = Warm Water 15 = Warm Water (Eco) 16 = Hot Water 17 = Freeze Prevention 18 = Cooled Water

**Table 10. Heat exchanger (HEX) (continued)**

Point Name	Property Name	Point Type	Description
VRF Occupancy Arbitration	Drive	Writeable-MSV	1 = Occupied 2 = Unoccupied 3 = Test Run
VRF Space Temperature Setpoint	SetTemp	Writeable-AV	Read/write the occupied setpoint. This point is only valid for single setpoint devices.
Water Inlet Temperature (TH6)	TH6	AI	TH6 Thermistor.
Water Outlet Temperature (TH8)	TH8	AI	TH8 Thermistor.
Water Temperature	TH11	AI	TH11 Thermistor. Discharge temperature.
Water Temperature Setpoint Active	TO	AI	Water Temperature Setpoint Active.

**Note:** \* = non-interoperable point for third-party BACnet® systems.



**Notes**

---



Trane - by Trane Technologies (NYSE: TT), a global innovator - creates comfortable, energy efficient indoor environments for commercial and residential applications. For more information, please visit [trane.com](http://trane.com) or [tranetechnologies.com](http://tranetechnologies.com).

Trane has a policy of continuous product and product data improvements and reserves the right to change design and specifications without notice. We are committed to using environmentally conscious print practices.

BAS-SVP044C-EN 12 Oct 2025  
Supersedes BAS-SVP044B-EN (May 2023)

©2025 Trane