



Installation

UHEC-IN-44

Library	Service Literature
Product Section	Air Terminal Devices and Heating Products
Product	Unit Heaters
Model	UHEC Accessories
Literature Type	Installation
Sequence	44
Date	April 1997
File No.	SV-TD-UH-UHEC-IN-44-497
Supersedes	EUH-IN-44C-1194

Power Disconnect Switch

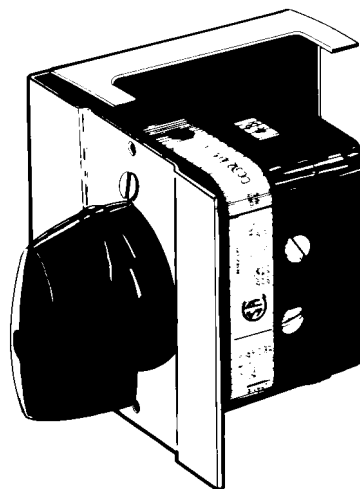

Model No.	Order No.	Description
DCS 323	236-702	(3-Pole, 32A, 120-600 VAC Resistive)
DCS 632	233-703	(2-Pole, 63A, 120-600 VAC Resistive)
DCS 633	233-704	(3-Pole, 63A, 120-600 VAC Resistive)

9489

Since the Trane Company has a policy of continuous product improvement, it reserves the right to change specifications and design without notice. The installation and servicing of the equipment referred to in this booklet should be done by qualified, experienced technicians.

Installation Instructions

Disconnect Switches With Terminal Shield (Figures 1 and 2)

Procedure

⚠ WARNING!
Open supply circuit disconnect switch before servicing unit. Failure to do so may result in personal injury or death from electrical shock.

Note: Before installing disconnect switch, check heater data tape to ensure that heater electrical rating does not exceed the disconnect switch electrical rating.

⚠ Caution:
All wiring must be done in accordance with NEC, CEC and local electrical codes. Supply conductors to the unit must be copper.

1. Disconnect heater from power supply.
2. Locate and remove large knockout and two adjacent small knockouts from back of heater.

Figure 1
Switch Location on 7KW Thru 20KW Units With Terminal Shield

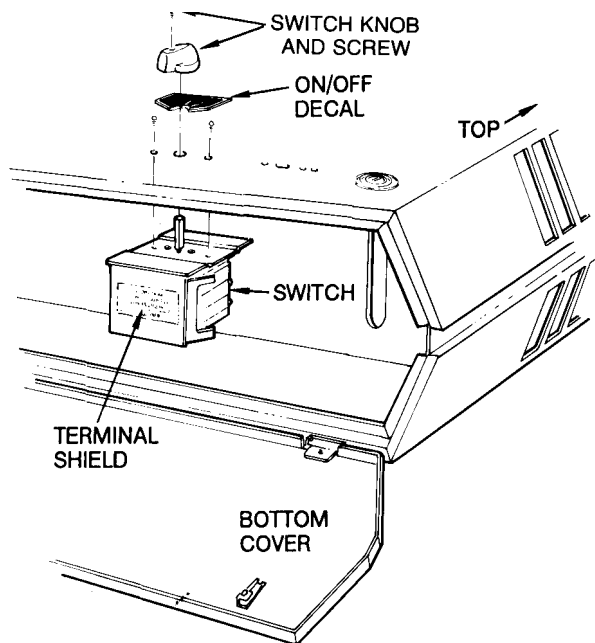

a. **7KW thru 20KW units** - a 5/8-inch (16mm) wide knockout slot is located on the heater back approximately 3-1/2" (89mm) from the bottom of the unit with a small knockout on either side (Figure 1).

Note: In some instances, due to restricted space in the control compartment of 480V and 600V heaters, the disconnect switch (Model DCS 633) must be mounted to the left-front of the cabinet using the three knockouts (a 1/2-inch (13mm) with a 3/16-inch (5mm) knockout on either side) located there (2-1/2" (64mm) from the bottom).

b. **25KW thru 50KW units** - a 13/32-inch (10mm) diameter knockout located on the left hand side of the heater front with a small knockout on either side (Figure 2).

3. Remove paper backing from "ON-OFF" decal and affix it to heater above large knockout hole with lettering toward top of heater.
4. Attach switch bracket assembly to heater with the two No. 8 screws provided.

Note: Switch bracket assembly must be attached to heater with switch terminal barrier section toward bottom of heater. See Figure

1 or 2. Data and caution tapes on switch bracket must be plainly visible after installation. Do not remove fiber barrier from switch mounting bracket.

5. Loosen switch knob screw, push knob on switch, check for proper alignment with "ON-OFF" decal and tighten switch knob screw. When the switch shaft is turned fully counterclockwise, the switch will be in the "OFF" position.
6. Wire switch according to wiring diagram located on inside of heater bottom cover.

a. Attach switch leads T1, T2 and T3 to terminals L1, L2 and L3 of heater terminal block.

b. Attach switch leads L1, L2 and L3 by incoming conductors L1, L2 and L3 by suitable means.

Note: Switch Model DCS 632 has leads marked T1, T2 and L1, L2 only.

Complete the installation with steps 7 thru 9 shown on the following page.

Figure 2
Switch Location on 25KW Thru 50KW Units With Terminal Shield

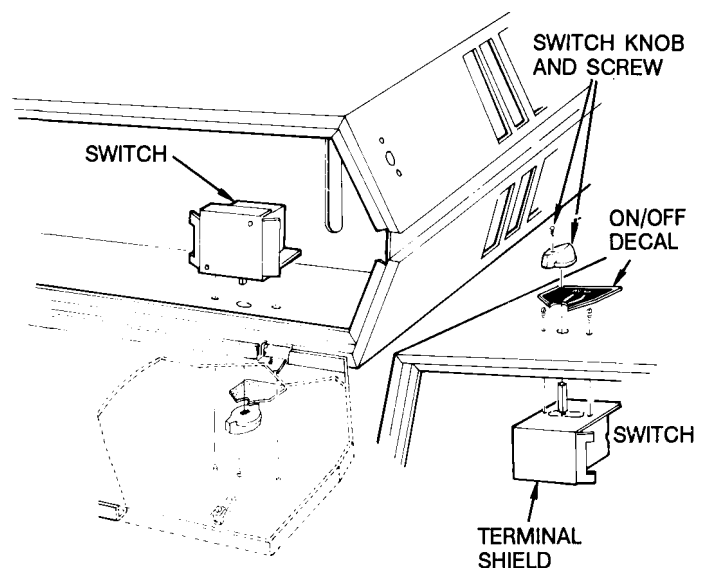

Installation Instructions

Disconnect Switches Without Terminal Shield (Figures 3 and 4)

Procedure

⚠ WARNING!
Open supply circuit disconnect switch before servicing unit. Failure to do so may result in personal injury or death from electrical shock.

Note: Before installing disconnect switch, check heater data tape to ensure that heater electrical rating does not exceed the disconnect switch electrical rating.

⚠ Caution:
All wiring must be done in accordance with NEC, CEC and local electrical codes. Supply conductors to the unit must be copper.

1. Disconnect heater from power supply.
2. Locate and remove large knockout and two adjacent small knockouts from back of heater.

Figure 3
Switch Location on 7.0KW Thru 20KW Units Without Terminal Shield

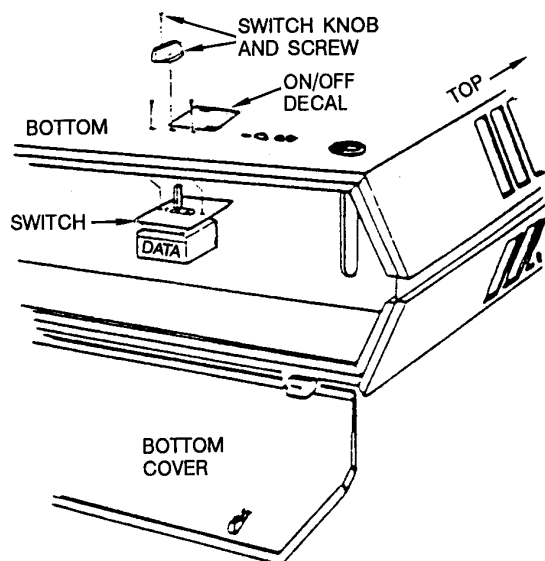

- a. **7KW thru 20KW units** - a 5/8-inch (16mm) wide knockout slot is located on the heater back approximately 3-1/2" (89mm) from the bottom of the unit with a small knockout on either side (Figure 3).

Note: In some instances, due to restricted space in the control compartment of 480V and 600V heaters, the disconnect switch (Model DCS 633) must be mounted to the left-front of the cabinet using the three knockouts (a 1/2-inch (13mm) with a 3/16-inch (5mm) knockout on either side) located there (2-1/2" (64mm) from the bottom).

- b. **25KW thru 50KW units** - a 13/32-inch (10mm) diameter knockout located on the left hand side of the heater **front** with a small knockout on either side (Figure 4).
3. Remove the knob from the switch by loosening the screw in the center of the knob and pulling it off.
 4. Connect the incoming power supply leads to terminals L1-L2-L3 of the disconnect switch. Connect the incoming ground lead to the grounding screw (or lug). On some models with adequate access, the switch may be mounted (Step 5) prior to connecting supply power wiring.

5. Mount the switch inside the heater control compartment, with the shaft extending through the knockout, using the two No. 8 x 5/16-inch (8mm) Phillips-head screws provided. The switch should be oriented so the side with the data label is facing the open side of the compartment (visible when installed). Be careful to position all electrical wiring so that it is not pinched or otherwise damaged.
6. Connect the leadwires on the switch (marked T1-T2-T2) to the heater power terminal block (marked L1-L2-L3). Switch model DCS 632 will have only leadwires marked T1 and T2, which will be connected to the power terminal block at L1 and L2.
7. Install the knob and tighten the knob mounting screw.
8. Attach the "ON-OFF" decal as shown in Figures 3 and 4. Peel off the backing paper, position carefully, then press firmly onto the heater cabinet. Note that knob rotation clockwise is "ON" and counterclockwise is "OFF".
9. Check all connections for tightness and electrical clearances. Close cover and latch, then restore electrical power and check heater in each mode of operation.

Figure 4
Switch Location on 25KW Thru 50KW Units Without Terminal Shield

