

Installation Guide

Split System Air Conditioners Odyssey™ with Symbio™ Controls R-454B

Wiring and Start-Up

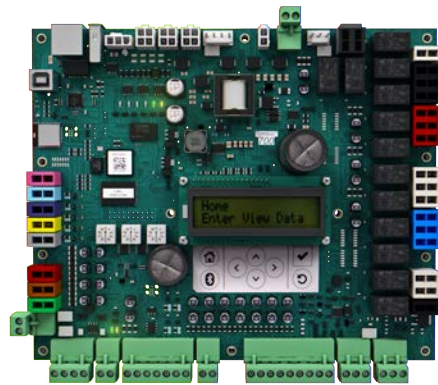

⚠ SAFETY WARNING

Only qualified personnel should install and service the equipment. The installation, starting up, and servicing of heating, ventilating, and air-conditioning equipment can be hazardous and requires specific knowledge and training. Improperly installed, adjusted or altered equipment by an unqualified person could result in death or serious injury. When working on the equipment, observe all precautions in the literature and on the tags, stickers, and labels that are attached to the equipment.

October 2024

SS-SVN017B-EN

Warnings, Cautions, and Notices

Safety advisories appear throughout this manual as required. Your personal safety and the proper operation of this machine depend upon the strict observance of these precautions.

The three types of advisories are defined as follows:



Indicates a potentially hazardous situation which, if not avoided, could result in death or serious injury.



Indicates a potentially hazardous situation which, if not avoided, could result in minor or moderate injury. It could also be used to alert against unsafe practices.



Indicates a situation that could result in equipment or property-damage only accidents.

Important Environmental Concerns

Scientific research has shown that certain man-made chemicals can affect the earth's naturally occurring stratospheric ozone layer when released to the atmosphere. In particular, several of the identified chemicals that may affect the ozone layer are refrigerants that contain Chlorine, Fluorine and Carbon (CFCs) and those containing Hydrogen, Chlorine, Fluorine and Carbon (HCFCs). Not all refrigerants containing these compounds have the same potential impact to the environment. Trane advocates the responsible handling of all refrigerants.

Important Responsible Refrigerant Practices

Trane believes that responsible refrigerant practices are important to the environment, our customers, and the air conditioning industry. All technicians who handle refrigerants must be certified according to local rules. For the USA, the Federal Clean Air Act (Section 608) sets forth the requirements for handling, reclaiming, recovering and recycling of certain refrigerants and the equipment that is used in these service procedures. In addition, some states or municipalities may have additional requirements that must also be adhered to for responsible management of refrigerants. Know the applicable laws and follow them.

WARNING

Proper Field Wiring and Grounding Required!

Failure to follow code could result in death or serious injury.

All field wiring MUST be performed by qualified personnel. Improperly installed and grounded field wiring poses FIRE and ELECTROCUTION hazards. To avoid these hazards, you MUST follow requirements for field wiring installation and grounding as described in NEC and your local/state/national electrical codes.

⚠ WARNING

Personal Protective Equipment (PPE) Required!

Failure to wear proper PPE for the job being undertaken could result in death or serious injury. Technicians, in order to protect themselves from potential electrical, mechanical, and chemical hazards, **MUST** follow precautions in this manual and on the tags, stickers, and labels, as well as the instructions below:

- Before installing/servicing this unit, technicians **MUST** put on all PPE required for the work being undertaken (Examples; cut resistant gloves/sleeves, butyl gloves, safety glasses, hard hat/bump cap, fall protection, electrical PPE and arc flash clothing). **ALWAYS** refer to appropriate Safety Data Sheets (SDS) and OSHA guidelines for proper PPE.
- When working with or around hazardous chemicals, **ALWAYS** refer to the appropriate SDS and OSHA/GHS (Global Harmonized System of Classification and Labelling of Chemicals) guidelines for information on allowable personal exposure levels, proper respiratory protection and handling instructions.
- If there is a risk of energized electrical contact, arc, or flash, technicians **MUST** put on all PPE in accordance with OSHA, NFPA 70E, or other country-specific requirements for arc flash protection, **PRIOR** to servicing the unit. **NEVER PERFORM ANY SWITCHING, DISCONNECTING, OR VOLTAGE TESTING WITHOUT PROPER ELECTRICAL PPE AND ARC FLASH CLOTHING. ENSURE ELECTRICAL METERS AND EQUIPMENT ARE PROPERLY RATED FOR INTENDED VOLTAGE.**

⚠ WARNING

Follow EHS Policies!

Failure to follow instructions below could result in death or serious injury.

- All Trane personnel must follow the company's Environmental, Health and Safety (EHS) policies when performing work such as hot work, electrical, fall protection, lockout/tagout, refrigerant handling, etc. Where local regulations are more stringent than these policies, those regulations supersede these policies.
- Non-Trane personnel should always follow local regulations.

⚠ WARNING

R-454B Flammable A2L Refrigerant!

Failure to use proper equipment or components as described below could result in equipment failure, and possibly fire, which could result in death, serious injury, or equipment damage. The equipment described in this manual uses R-454B refrigerant which is flammable (A2L). Use **ONLY** R-454B rated service equipment and components. For specific handling concerns with R-454B, contact your local representative.

Copyright

This document and the information in it are the property of Trane, and may not be used or reproduced in whole or in part without written permission. Trane reserves the right to revise this publication at any time, and to make changes to its content without obligation to notify any person of such revision or change.

Trademarks

All trademarks referenced in this document are the trademarks of their respective owners.

Revision History

- Update to the Condenser and Air Handler Pairing Instructions table.
- Added simplified wiring options for thermostat control with constant and two speed air handling units, both condenser cooling and heat pump.
- Expanded the pairing options for full featured control of thermostat and zone sensor applications.

Table of Contents

Overview	6
Standard Thermostat Functionality	7
Wiring Requirements	7
Condenser and Air Handler Pair Wiring Information	7
Pairing A (Condenser Cooling / Thermostat)	9
Pairing A (Heat Pump / Thermostat)	10
Pairing H for Condenser Cooling	11
Pairing H for Heat Pump Operation	12
Air Handling Unit Modifications	13
Configure the Symbio 700 Controller	14
Air Handler to Condenser Connections	15
Full-Featured Functionality	16
Wiring Requirements	16
Thermostat Control Wire	16
Zone Sensor Wire	16
Shielded Twisted Pair Cable	16
Condenser and Air Handler Pairings	16
Thermostat and Zone Sensor Wiring	19
Condenser and Air Handler Pair Wiring Information	20
Pairing A	20
Pairing H	24
Pairing B	29
Symbio Service and Installation Mobile Application	34
Download Mobile App	34
Connecting to the Symbio 700	34
Required Tools	34
Connecting to the Symbio 700 Controller	35
Troubleshooting	37
Navigation	37
Editing Equipment Configuration	39
Viewing Alarms	40
Service Test Mode	41
Symbio 700 User Interface	42
Editing Equipment Configuration	44
Viewing Alarms	45
Service Test Mode	46
More Information and Technical Support	47

Overview

This guide provides instructions for the wiring of R-454B applications. For information regarding R-410A split system applications, please refer to SS-SVN016*-EN.

The information in this guide is specifically applicable to Trane Odyssey air handling units that are paired with Trane Odyssey condensing units.

In most cases, Odyssey split system applications offer standard thermostat functionality with simplified field wiring. However, there are also full-featured options available for single zone VAV applications and installations with zone sensors. For more details, please refer to the table provided below.

Table 1. Symbio 700/Odyssey standard and full featured options

		24V Thermostat Control Simplified Wiring	Full Featured Communication Wiring Required	
Type	Cooling Condenser	✓	✓	
	Heat Pump	✓	✓	
Thermostat or Zone Sensor	Thermostat Control	✓	✓	
	Zone Sensor		✓	
AHU Supply Fan Control	Constant Speed	✓ ^(a)	✓ ^(b)	
	Two Speed	✓	✓	
	Variable Speed		Digit 15 = C	Digit 15 = D ✓
Control Board License	Basic	✓	✓ ^(e)	
	Advanced	✓ ^(c)	✓ ^(c)	
BMS Communication	BACnet MS/TP		✓ ^(e)	
	BACnet/IP		✓ ^(e)	
	Modbus RTU		✓ ^(e)	
	Modbus TCP		✓ ^(e)	
Installation Type	Retrofit	✓	✓	
	New	✓	✓	
Symbio Mobile App		✓	✓	
Trane Connect Remote Access		✓ ^(d)	✓ ^(d)	
R-454B (A2L) Mitigation		✓	✓	
Evaporator Defrost Control		✓	✓	
Input/Output Point Expansion		✓ ^(e)	✓ ^(e)	
Custom Programming		✓ ^(e)	✓ ^(e)	
Service Test Mode		✓ ^(f)	✓	
Equipment Shutdown Input			✓	
Heat Control in Defrost			✓	
Demand Limit / Demand Shed			✓	
Supply Air Tempering			✓	

^(a) For factory-provided constant speed, select Digit 15 = 1.

^(b) Not a factory-provided solution for Digit 15 = C or D.

^(c) The thermostat/light applications can be accomplished with either the basic or advanced license, while the full featured applications require the advanced license.

^(d) Requires network connection.

^(e) Requires the Advanced controller license.

^(f) Cooling stages only. Supply fan and heat stages must be overridden by other means.

Standard Thermostat Functionality

For pairing applications where control is provided by the thermostat, wiring between the air handler and condenser is reduced to a single cable for both condenser cooling and heat pump applications. In these applications, the thermostat provides control of the split system. The Symbio™ 700 accepts the Y1, Y2 (optional), O (heat pump only), and Limit/Shed (compressor disable) inputs from the thermostat/AHU.

Wiring Requirements

Thermostat and Control Wire

Table 2. Recommended thermostats and control wire size and length

Wire Gauge	Maximum Wire Length
22	30 feet
20	50 feet
18	75 feet
16	125 feet
14	200 feet

Condenser and Air Handler Pair Wiring Information

Table 3. Model number descriptions

Symbio Air Handler
<p>Digit 15 — Controls</p> <p>1 = Constant Speed C = 2-speed D = Single Zone VAV (See note below)</p> <p>Notes:</p> <ul style="list-style-type: none"> When a thermostat is applied to Model Digit 15 = D (SZVAV), the resulting fan speed control is automatically limited to two speeds (no additional configuration needed), but communication wiring is required between the indoor AHU and outdoor condenser. Converting the SZVAV AHU for two speed fan operation enables simplified wiring between the indoor AHU and outdoor condenser, but with limited functionality compared to the note above.

Standard Thermostat Functionality

Table 4. Condenser and air handler pairing details — simplified thermostat wiring

Condenser (model # digit)	Air Handler		Application	Wiring Reference	Description
	Type	Supply Fan Type (model # digit)			
Odyssey Symbio (Digit 15 = S)	Odyssey Symbio	Constant Volume (Digit 15 = 1)	Condenser Cooling	Figure 1, p. 9	There is no VFD in this scenario, as the fan control is provided by directly by the contactor.
			Heat Pump	Figure 2, p. 10	Important: Additional Symbio 700 setup is necessary for the simplified wiring. Control is provided by the thermostat, not the Symbio 700. Symbio 700 controls the cooling stages and heat pump reversing valve, when applicable. Electric Heat will not operate in heat pump defrost mode.
		2-Speed Fan (Digit 15 = C)	Condenser Cooling	Figure 3, p. 11	The VFD wiring harness and programming is factory installed in this scenario.
			Heat Pump	Figure 4, p. 12	Important: Additional Symbio 700 setup is necessary for the simplified wiring. Control is provided by the thermostat, not Symbio 700. Symbio 700 controls the cooling stages and heat pump reversing valve, when applicable. Electric heat will not operate in heat pump defrost mode.
		Single Zone VAV (Digit 15 = D)	Condenser Cooling	Figure 3, p. 11	If the AHU was ordered for SZVAV (Model Digit 15 = D), there are two options to consider for two speed operation:
			Heat Pump	Figure 4, p. 12	<ul style="list-style-type: none"> For full featured capability, wire the 24V thermostat to the Symbio 700. Refer to Pairing B in the full featured section of this manual. No AHU conversion required for this scenario. For simplified wiring between the AHU and condenser, the AHU must first be converted from SZVAV to two speed. This conversion requires a wiring harness. Refer to Pairing H in the simplified wiring section of this manual.

Pairing A (Condenser Cooling / Thermostat)

Figure 1. Pairing A for constant speed condenser cooling thermostat control applications

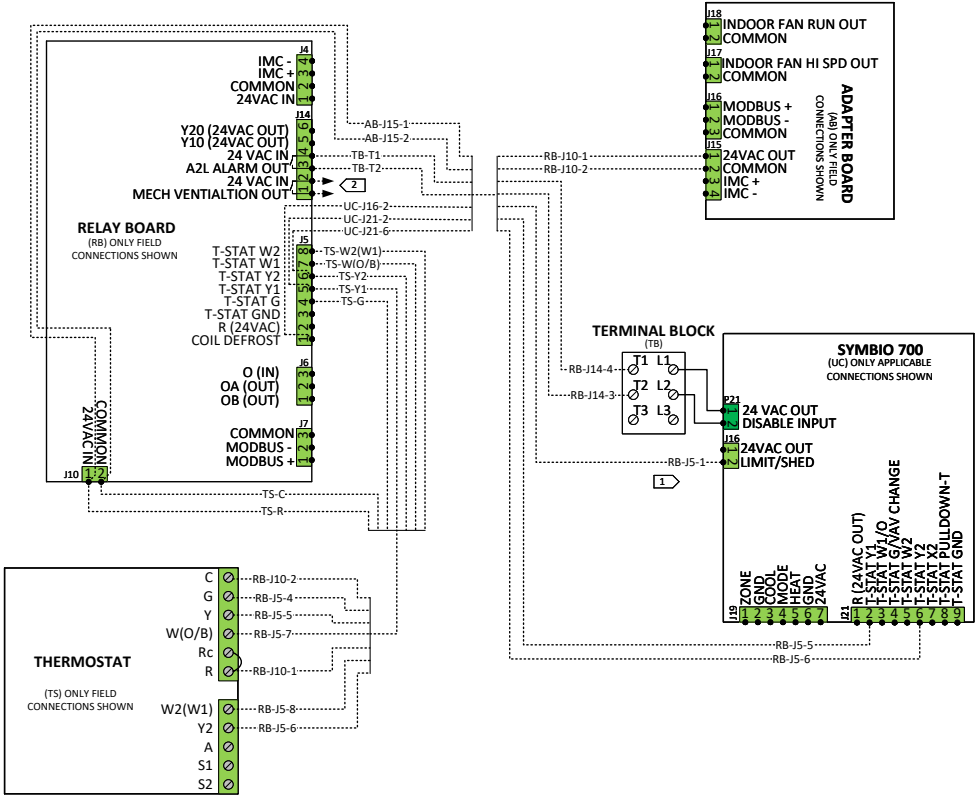
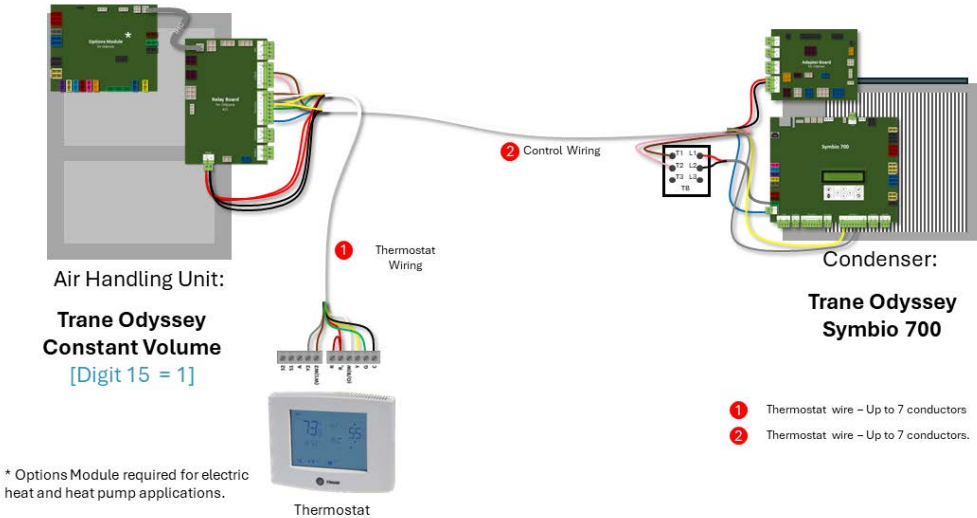

Notes:

1. If EDC switch in the Symbio Air Handler unit will be utilized for low evaporator compressor protection, connection between relay board (J5-1) and Symbio 700 (J16-2) will be required. Otherwise, this connection can be omitted.
2. Use Mechanical Ventilation Output contacts (N.O.) to enable external ventilation system when required by the application. (Contact Rating: 24VAC/VDC, 2 AMPS).

Pairing A (Heat Pump / Thermostat)

Figure 2. Pairing A for constant speed heat pump thermostat control applications

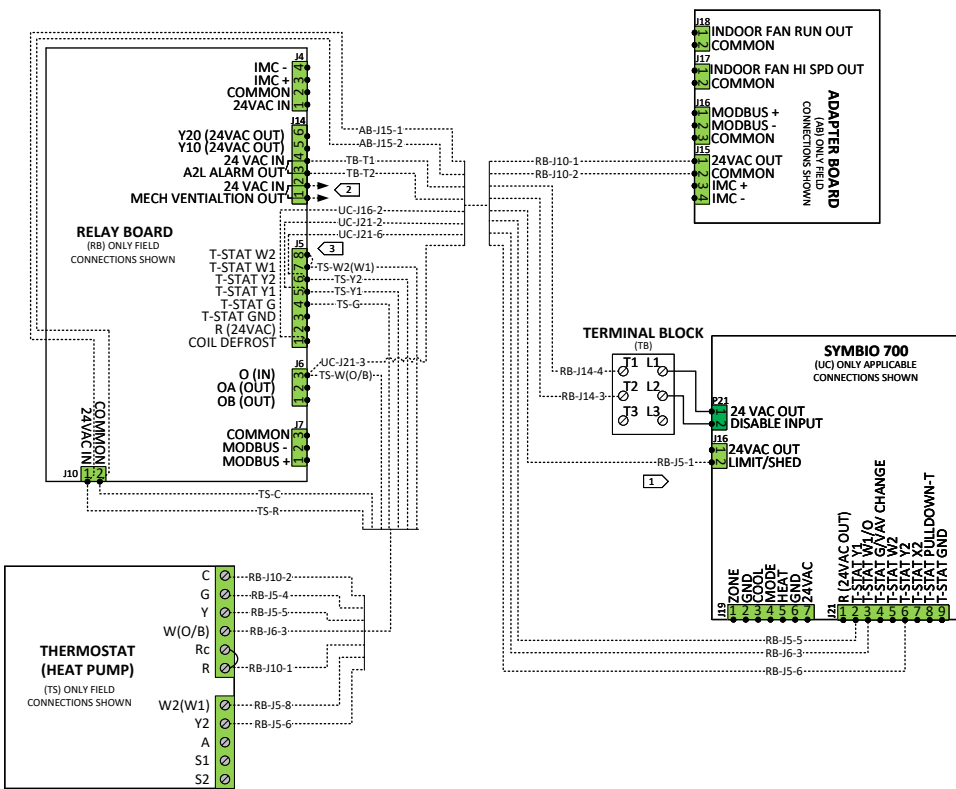
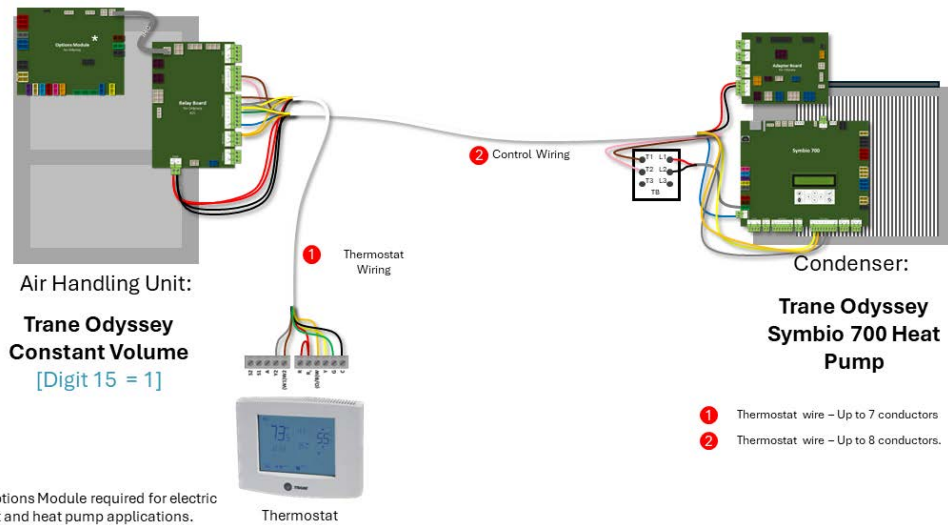

Notes:

1. If EDC switch in the Symbio Air Handler unit will be utilized for low evaporator compressor protection, connection between relay board (J5-1) and Symbio 700 (J16-2) will be required. Otherwise, this connection can be omitted.
2. Use Mechanical Ventilation Output contacts (N.O.) to enable external ventilation system when required by the application. (Contact Rating: 24VAC/VDC, 2 AMPS).
3. If electric auxiliary heat is available, install jumper between W1 and W2 at the Relay Board. Thermostat auxiliary heat call W2(W1) will energize electric heat stages.

Pairing H for Condenser Cooling

Figure 3. Pairing H for two speed condenser cooling thermostat control applications

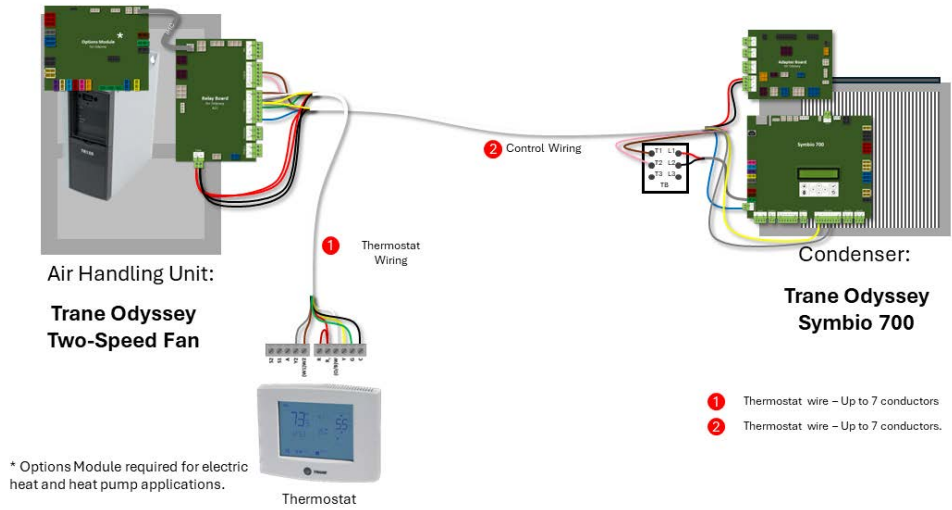

* Options Module required for electric heat and heat pump applications.

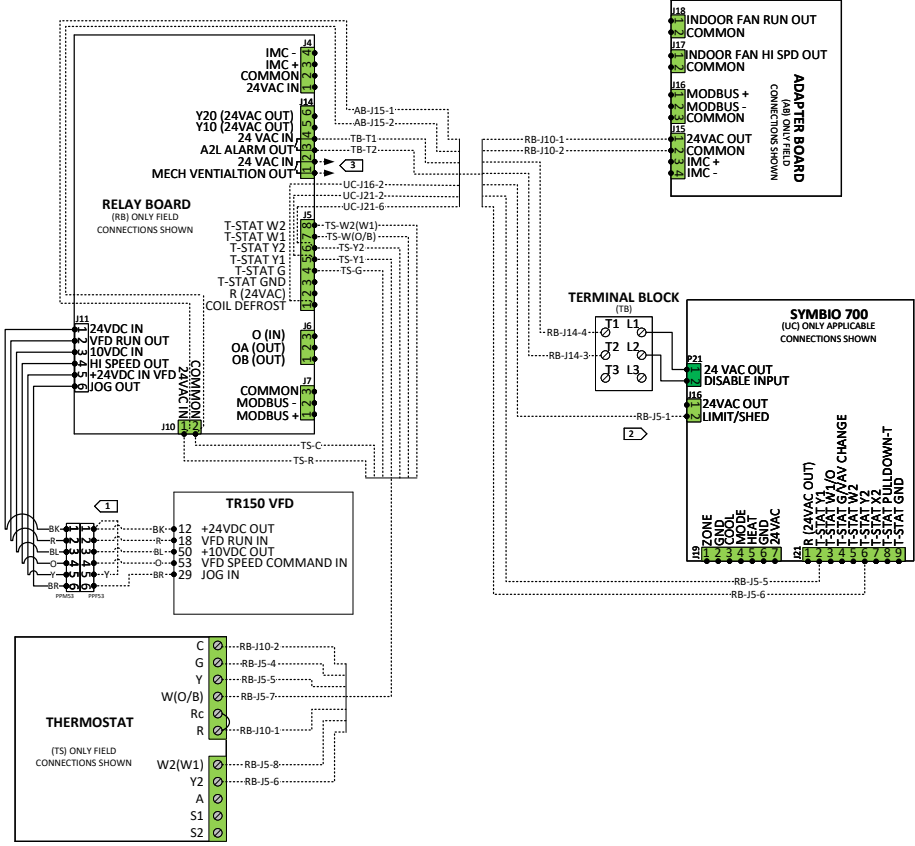

Notes:

1. For Symbio Air Handlers SZVAV (Digit 15=D), wire harness WIR13328 will be required. Wire harness can be purchased from Trane Supply.
2. If EDC switch in the Symbio Air Handler unit will be utilized for low evaporator compressor protection, connection between relay board (J5-1) and Symbio 700 (J16-2) will be required. Otherwise, this connection can be omitted.
3. Use Mechanical Ventilation Output contacts (N.O.) to enable external ventilation system when required by the application. (Contact Rating: 24VAC/VDC, 2 AMPS).

Pairing H for Heat Pump Operation

Figure 4. Pairing H for two speed heat pump thermostat control applications

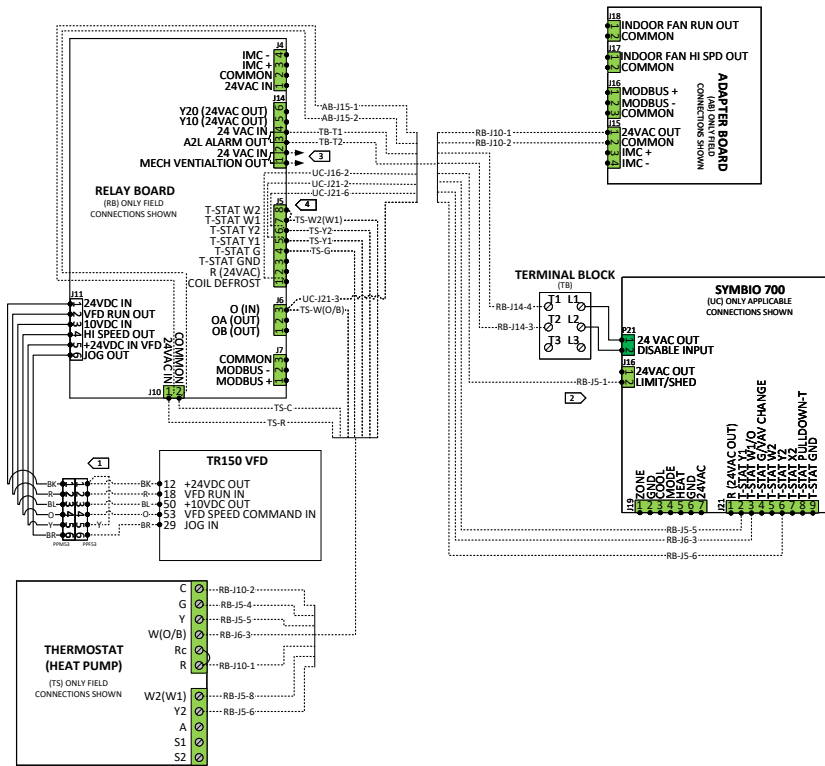
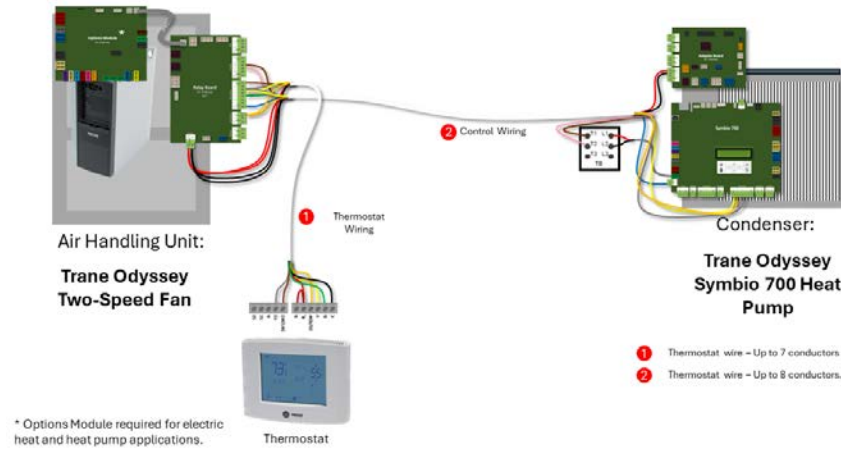

Notes:

1. For Symbio Air Handlers SZVAV (Digit 15=D), wire harness WIR13328 will be required. Wire harness can be purchased from Trane Supply.
2. If EDC switch in the Symbio Air Handler unit will be utilized for low evaporator compressor protection, connection between relay board (J5-1) and Symbio 700 (J16-2) will be required. Otherwise, this connection can be omitted.
3. Use Mechanical Ventilation Output contacts (N.O.) to enable external ventilation system when required by the application. (Contact Rating: 24VAC/VDC, 2 AMPS).
4. If electric auxiliary heat is available, install jumper between W1 and W2 at the Relay Board. Thermostat auxiliary heat call W2(W1) will energize electric heat stages.

Air Handling Unit Modifications

If the Symbio Air Handling Unit was selected as Single Zone VAV (Digit 15=D) the following changes will be required:

1. Remove the existing wire harness from PPF53 and VFD terminals 12 and 29. This harness is not used with the Standard Thermostat Simplified Wiring Configuration.
2. Connect wiring harness WIR13328 from PPM53 to VFD terminals 12, 18, 50, 53, and 29.

The following parameters must also be updated in the TR150 VFD:

1. Change 3-15 from [11] Local Bus reference to [1] Analog Input 53.
2. Change 5-10 from [0] No Operation to [8] Start.
3. Change 8-01 from [2] Control Word Only to [0] Digital and Control Word.
4. Verify 4-12 is set to 25 HZ.
5. Verify 4-14 is set to 60 HZ.
6. Verify 6-10 is set to 0.07V.
7. Verify 6-11 is set to 10.00V.
8. Verify 6-14 is set to 25 HZ.
9. Verify 6-15 is set to 60 HZ.

If the Symbio air handling unit was selected for 2-speed operation (Digit 15=C), the necessary wiring and VFD setup steps were completed in the factory.

Configure the Symbio 700 Controller

When using the Standard Thermostat Simplified Wiring Configuration, heating, cooling, and AHU supply fan control is provided by the thermostat and not the Symbio 700 controller. For this configuration to work as intended, the following parameters must be properly configured in the Symbio 700 Controller:

- | | |
|------------------------------------|------------------------------------|
| 1. System Type: | CVZT |
| 2. Indoor Fan Type: | Single Speed^(a) |
| If unit is Condenser Cooling: | |
| 3. Primary Heating Source: | Not Installed^(b) |
| If the unit is Heat Pump: | |
| 3. Secondary Heating Source: | Not Installed |
| 4. Outside Air: | Not Installed |
| 5. Ventilation Override: | Not Installed |
| 6. Alarm Indicator: | Not Installed |
| 7. Space Controller: | Conventional TStat |
| 8. Demand Management: | None^(c) |
| 9. Humidity Sensor: | Not Installed |
| 10. CO ₂ Sensor: | Not Installed |
| 11. Demand Controlled Ventilation: | Not Installed |
| 12. Discharge Temperature Sensor: | Not Installed |

^(a) AHU model number differences:

- If Digit 15=1, unit will operate as a Constant Volume unit.
- If Digit 15=C, unit will operate as a 2-Speed Airflow.

• If Digit 15=D, once changes listed under "Air Handler Unit Modifications" are completed, the unit will operate as a 2-Speed Airflow.

^(b) If the Air Handler unit has electric heat, heat will be controlled by the Thermostat. Configure the Symbio 700 for primary heating source to "Not Installed" or, if unit is a Heat Pump, secondary Heating Source to "Not Installed".

^(c) If the EDC switch in the air handler will be used for low evaporator compressor protection, set configuration parameter Demand Management to Demand Limit and set Cooling Demand Limit Capacity Enable Setpoint to 0%.

Air Handler to Condenser Connections

Control wire – thermostat wire, up to eight conductors

Table 5. Pairing H air handler to condenser wiring

Conductor	Required/Optional	Air Handler Connection	Condenser Connection	Purpose	Detail
1	Required	RB-J10-1	AB-J15-1	24VAC	It is recommended that the air handler and condensing unit share low voltage power. If the air handler and condensing unit have separate low voltage power, these conductors can be omitted, but isolation relays are needed on the remaining control wire conductors.
2	Required	RB-J10-2	AB-J15-2	Ground	
3	Required	RB-J5-5	UC-J21-2	Y1	Cooling Stage 1
4	Optional	RB-J5-6	UC-J21-6	Y2	Cooling Stage 2, when applicable
5	Optional	RB-J5-1	UC-J16-2	Limit/Shed	Evaporator defrost (compressor disable)
6	Required	RB-J14-4	TB-T1	A2L Alarm 24VAC	A2L Alarm indication (compressor disable)
7	Required	RB-J14-3	TB-T2	A2L Alarm Output	
8	Optional	RB-J6-3	UC-J21-3	W1/O	Heat pump reversing valve (heat pump applications only)

Full-Featured Functionality

Wiring Requirements

Thermostat Control Wire

Table 6. Recommended thermostat control wire size

Wire Gauge	Maximum Wire Length
22	30 feet
20	50 feet
18	75 feet
16	125 feet
14	200 feet

Zone Sensor Wire

Table 7. Zone sensor module wiring

Distance from Unit to Control	Recommended Wire Size
0–150 feet (0–45.7 meters)	22 gauge (0.33 mm ²)
151–240 feet (46–73.1 meters)	20 gauge (0.5 mm ²)

Shielded Twisted Pair Cable

A shielded twisted pair cable is required for Symbio condenser installations where the indoor air handler is variable speed supply fan (VFD) and/or electric heat. See Air Handler and Condenser pairing information for more details regarding shield twisted pair cable installation requirements.

Trane Purple Wire is recommended when shielded twist pair cable is required (see the following table).

Part Number	Description
CAB01568	Cable, comlink cable with PVC jacket, 18/1 pr, stranded shield, 25PF plenum, 100 foot length
CAB01569	Cable, comlink cable with PVC jacket, 18/1 pr, stranded shield, 25PF plenum, 1,000 foot length

Alternate shield twisted pair cable can be used if it conforms to the following physical characteristics:

- Twisted pair (two-conductor) plus shield
- Characteristic impedance: 100 and 130 ohms
- Distributed capacitance between conductors: < 100 pF/m
- Distributed capacitance between conductor and shield: < 200 pF/m
- Foil or braided shield is acceptable
- Wire diameter: 22 to 18 AWG

Condenser and Air Handler Pairings

Table 8. Model number descriptions

TWE Air Handler with Symbio
<p>Digit 15 — Controls</p> <p>1 = Constant Volume C = 2-Speed D = Single Zone VAV (requires zone sensor for variable fan speed operation)</p>

Table 9. Condenser and air handler pairing instructions

Condenser (model # digit)	Air Handler		Application	Thermostat or Zone Sensor	Wiring Reference	Description
	Type	Supply Fan Type (model # digit)				
Odyssey Symbio (Digit 15 = S)	Odyssey Symbio	Constant Volume (Digit 15 = 1)	Condenser Cooling or Heat Pump	Thermostat	Figure 6, p. 20	Wire the thermostat to the Symbio 700. Install a thermostat control cable between the Air Handler and condenser. Install a twisted pair communication cable if the Air Handler has Electric Heat and for heat pump defrost (Trane IMC communication). Install BACnet MS/TP communication wiring, when applicable.
				Zone Sensor	Figure 7, p. 21	Wire the zone sensor to the Symbio 700. Install a thermostat control cable between the Air Handler and condenser. Install a twisted pair communication cable if the Air Handler has Electric Heat (Trane IMC communication). Install BACnet MS/TP communication wiring, when applicable.
				Air-Fi Wireless	Figure 8, p. 22	Wire the Wireless Communication Interface (WCI) to the Relay Board in the Air Handler. Install a thermostat control cable between the Air Handler and condenser. Install a twisted pair communication cable (Trane IMC communication).
	Odyssey Symbio	2-Speed Fan (Digit 15 = C)	Condenser Cooling or Heat Pump	Thermostat	Figure 9, p. 24	Wire the thermostat to the Symbio 700. Install a thermostat control cable between the Air Handler and condenser. Install a twisted pair communication cable for variable speed fan control (Modbus). Install a twisted pair communication cable for electric heat control in the Air Handler (Trane IMC communication). Install BACnet MS/TP communication wiring, when applicable.
				Zone Sensor	Figure 10, p. 25	Wire zone sensor to the Symbio 700. Install thermostat cable between Air Handler and Condenser. Install a twisted pair communication cable for supply fan speed control (Modbus). Install an additional twisted pair communication cable if the Air Handler has Electric Heat (Trane IMC communication). Install BACnet MS/TP communication wiring, when applicable.
				Air-Fi Wireless	Figure 11, p. 26	Wire the Wireless Communication Interface (WCI) to the Relay Board in the Air Handler. Install a thermostat control cable between the Air Handler and condenser. Heat control is accomplished with IMC, which will already be installed for Air-Fi applications. Install a twisted pair communication cable for supply fan speed control (Modbus).

Table 9. Condenser and air handler pairing instructions (continued)

Condenser (model # digit)	Air Handler		Application	Thermostat or Zone Sensor	Wiring Reference	Description
	Type	Supply Fan Type (model # digit)				
Odyssey Symbio (Digit 15 = S)	Odyssey Symbio	Single Zone VAV (Digit 15 = D)	Condenser Cooling or Heat Pump	Thermostat	Figure 12, p. 29	<p>With a 24V thermostat applied in this pairing, the resulting fan speed control will be two speeds.</p> <p>To enable SZVAV control with fully modulating supply fan, apply a zone sensor, either wired or wireless, as detailed in the two pairing examples below.</p> <p>Install a thermostat control cable between the Air Handler and condenser.</p> <p>Install a twisted pair communication cable for electric heat control in the Air Handler (Trane IMC communication).</p> <p>Install a second twisted pair communication cable for variable speed fan control (Modbus).</p> <p>Though similar to the simplified approach, this variation enables the full capabilities of the controller, without the need for field modifications, though IMC communication wiring between the AHU and condenser is required.</p>
				Zone Sensor	Figure 13, p. 30	<p>Wire the zone sensor to the Symbio 700.</p> <p>Install a thermostat control cable between the Air Handler and condenser.</p> <p>Install a twisted pair communication cable for electric heat control in the Air Handler (Trane IMC communication).</p> <p>Install a second twisted pair communication cable for variable speed fan control (Modbus).</p> <p>Install BACnet MS/TP communication wiring, when applicable.</p>
				Air-Fi Wireless	Figure 14, p. 31	<p>Wire the Wireless Communication Interface (WCI) to the Relay Board in the Air Handler.</p> <p>Install a thermostat control cable between the Air Handler and condenser.</p> <p>Install a twisted pair communication cable for two-speed fan control in the Air Handler (Trane IMC communication).</p> <p>Install a second twisted pair communication cable for variable speed fan control (Modbus).</p>

Thermostat and Zone Sensor Wiring

Figure 5. Thermostat or zone sensor wiring to Symbio 700 unit controller

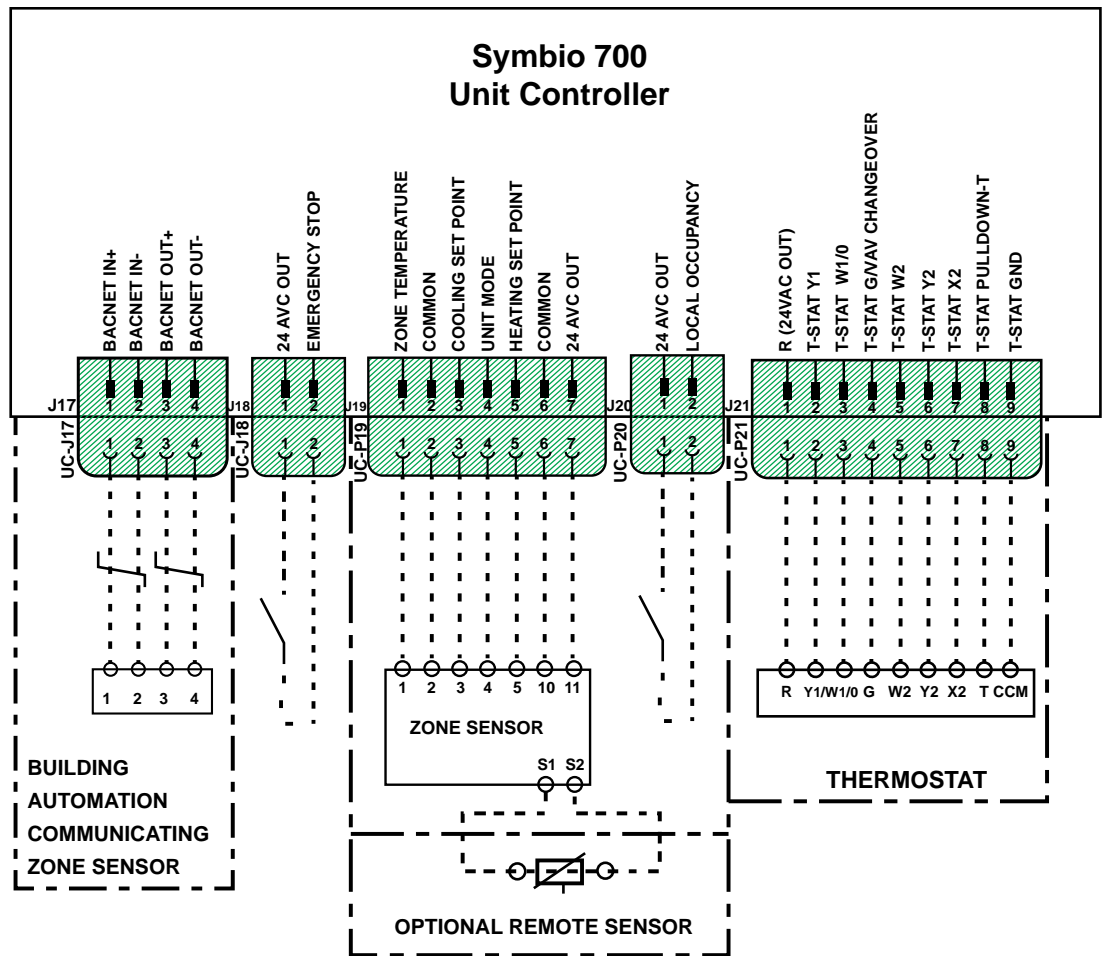

Connect a thermostat or other zone control device to the Symbio 700 Unit Controller. [Figure 5, p. 19](#) provides wiring guidance for zone sensor BAYSENS135.

Notes:

- Symbio controls do not support BAYSENS109 and BAYSENS110 sensor LED indicators.
- Symbio 700, J21-1 (R), is current limited. Alternately, thermostat 24VAC power can be connected at Adapter Board (AB) J15-1.

Condenser and Air Handler Pair Wiring Information

Pairing A

Figure 6. Pairing A for thermostat control applications

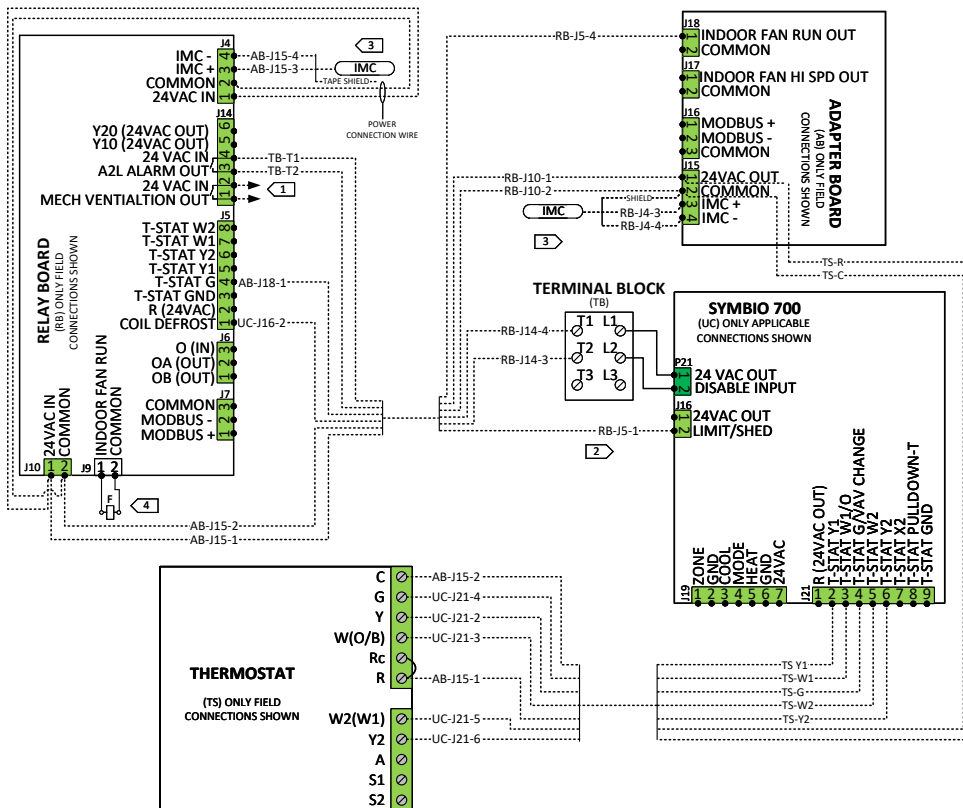
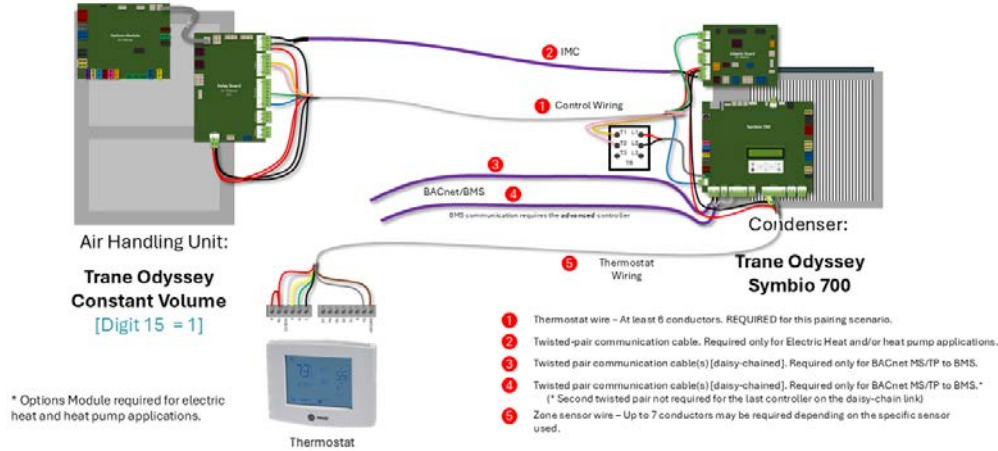

Notes:

1. Use Mechanical Ventilation Output contacts (N.O.) to enable external ventilation system when required by the application. (Contact Rating: 24VAC/VDC, 2 AMPS).
2. If EDC switch in the Symbio Air Handler unit will be utilized for low evaporator compressor protection, connection between relay board (J5-1) and Symbio 700 (J16-2) will be required. Otherwise, this connection can be omitted.
3. IMC communication wiring required for Air Handling Units equipped with electric heat.
4. Symbio 700 Equipment Stop input will not disable or prevent Supply Fan operation while refrigerant leak mitigation is active. If this feature is required, an additional safety interlock will need to be added in series with supply fan contactor coil "F".

Figure 7. Pairing A for zone sensor control applications

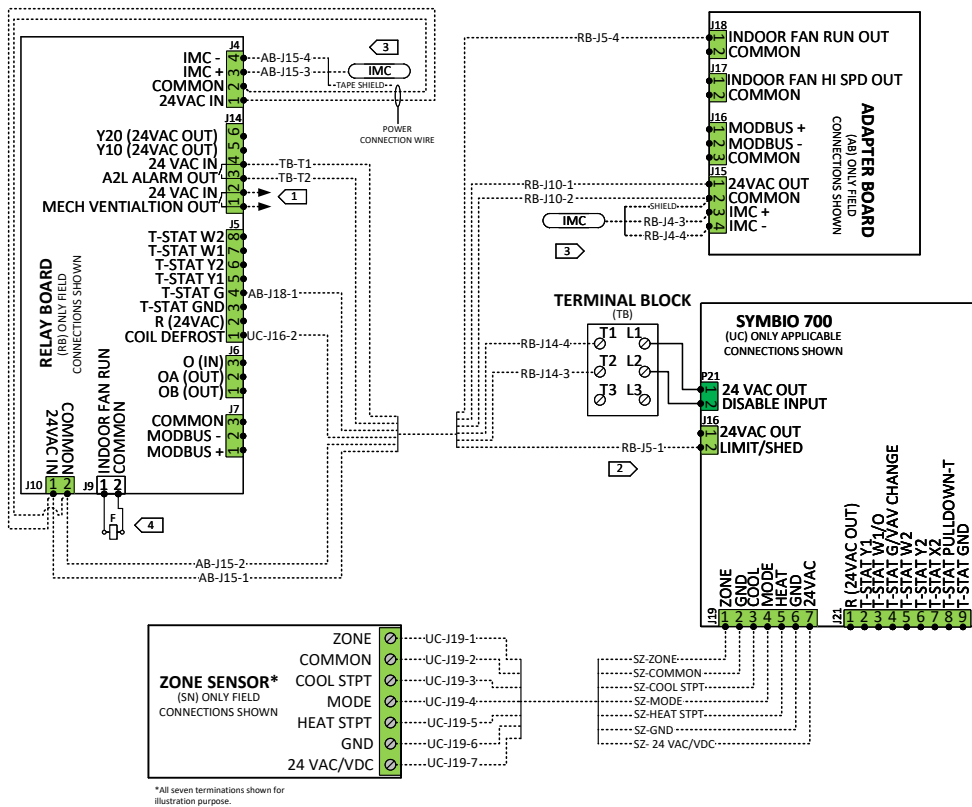
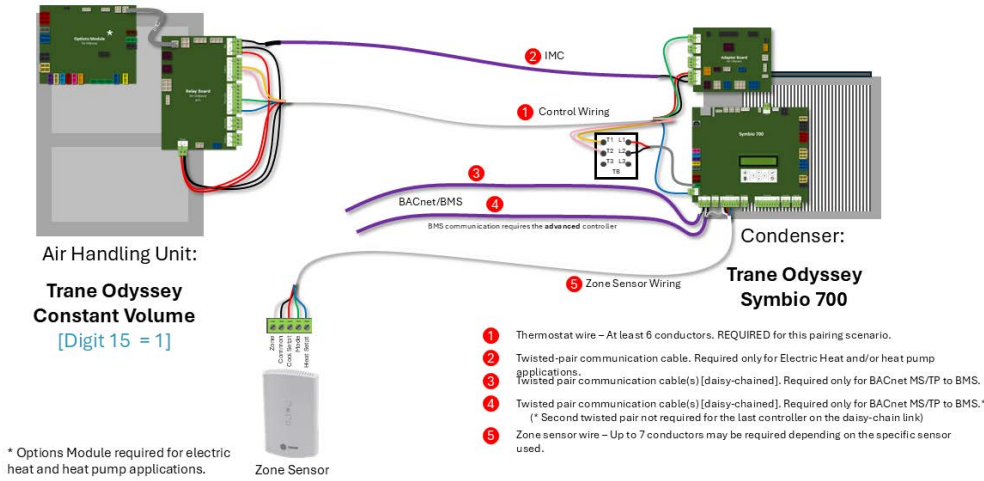

Notes:

1. Use Mechanical Ventilation Output contacts (N.O.) to enable external ventilation system when required by the application. (Contact Rating: 24VAC/VDC, 2 AMPS).
2. If EDC switch in the Symbio Air Handler unit will be utilized for low evaporator compressor protection, connection between relay board (J5-1) and Symbio 700 (J16-2) will be required. Otherwise, this connection can be omitted.
3. IMC communication wiring required for Air Handling Units equipped with electric heat.
4. Symbio 700 Equipment Stop input will not disable or prevent Supply Fan operation while refrigerant leak mitigation is active. If this feature is required, an additional safety interlock will need to be added in series with supply fan contactor coil "F".

Full-Featured Functionality

Figure 8. Pairing A for Air-Fi Wireless control applications

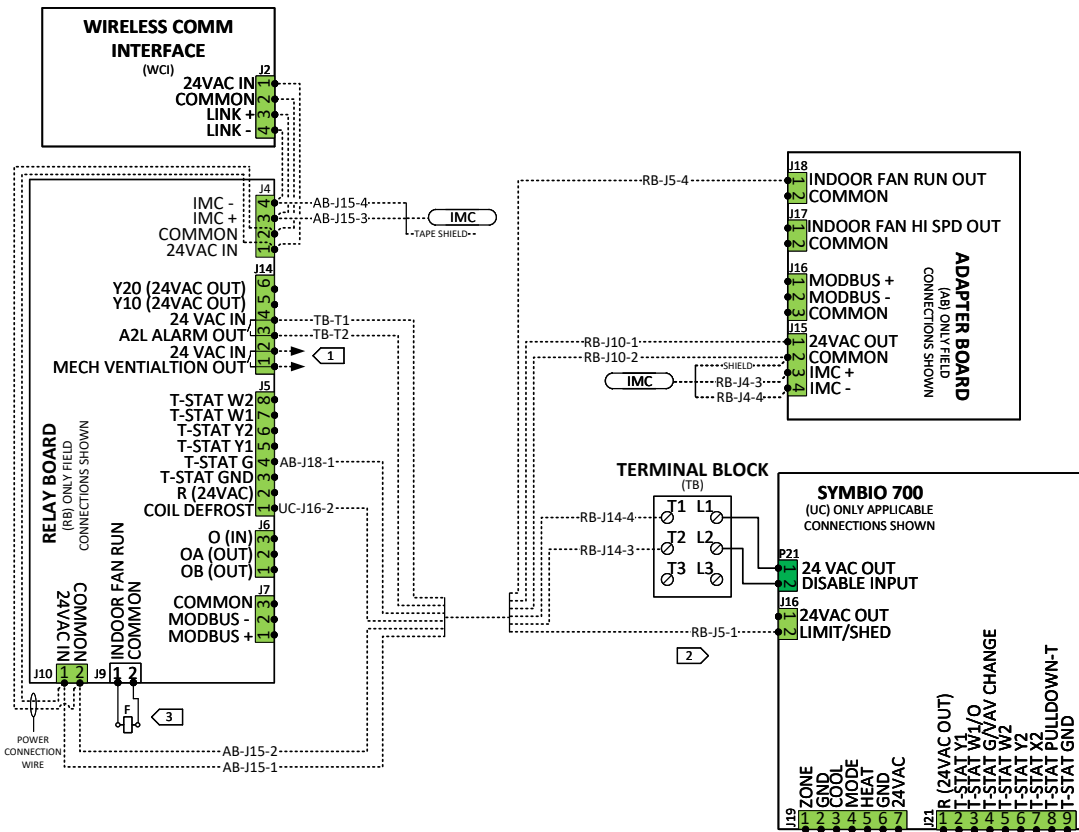
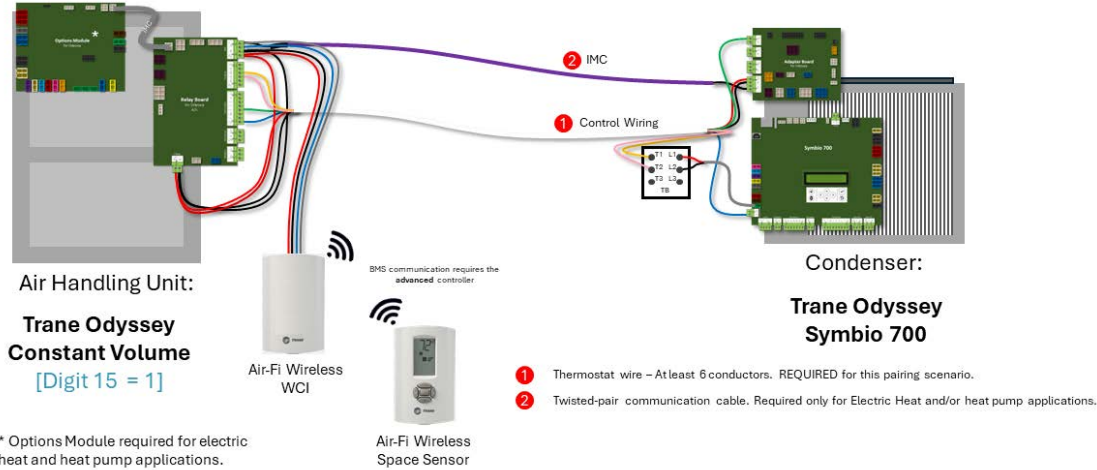

Notes:

1. Use Mechanical Ventilation Output contacts (N.O.) to enable external ventilation system when required by the application. (Contact Rating: 24VAC/VDC, 2 AMPS).
2. If EDC switch in the Symbio Air Handler unit will be utilized for low evaporator compressor protection, connection between relay board (J5-1) and Symbio 700 (J16-2) will be required. Otherwise, this connection can be omitted.
3. Symbio 700 Equipment Stop input will not disable or prevent Supply Fan operation while refrigerant leak mitigation is active. If this feature is required, an additional safety interlock will need to be added in series with supply fan contactor coil "F".

Zone Sensor or Thermostat Connections

See “Thermostat and Zone Sensor Wiring,” p. 19 for details on how to connect a zone sensor to J19 or thermostat to J21 on the Symbio 700 in the air handler. For SZVAV applications a space temperature sensor is required. Using a thermostat on a SZVAV air handler will result in two speed fan operation.

See “Symbio Service and Installation Mobile Application,” p. 34 for details on how to use the Symbio Service and Installation Mobile App to verify that configuration for space controller on the Symbio 700 matches the desired zone sensor or thermostat application.

Air Handler to Condenser Connections

Control Wire — Thermostat style wire up to six conductors

Table 10. Pairing A or B air handler to condenser wiring

Cond.	Required /Optional	Air Handler Connection	Condenser Connection	Purpose	Instructions
1	Required	(RB) J10-1	(AB) J15-1	24VAC	It is recommended that the air handler and condensing unit share low voltage power. If the air handler and condensing unit have separate low voltage power, these conductors can be omitted, but isolation relays are needed on the remaining control wire conductors.
2	Required	(RB) J10-2	(AB) J15-2	Ground	
3	Required	(RB) J5-4	(AB) J18-1	Supply fan	Command the constant volume indoor fan to run or will interlock a variable speed fan with the electric heat.
4	Optional	(RB) J5-1	(UC) J16-2	EDC	This conductor is optional and is only needed if compressor protection at low evaporator temperatures is desired. Reference page 28 for details on how to use the Symbio Service and Installation Mobile Application to set the configuration for Demand Management to Demand Limit, and in Settings change Cooling Demand Limit Capacity Enable Setpoint to 0%.
5	Required for A2L	(RB) J14-3	TB-T2	A2L Indication	This input is used to initiate the A2L response to disable cooling and initiate fan and ventilation sequences accordingly.
6	Required for A2L	(RB) J14-4	TB-T1	A2L Indication	

Shielded Twisted Pair Cable — up to two cables

Table 11. Pairing A twisted pair cable wiring

Cable	Required/ Optional	Air Handler Connection	Condenser Connection	Purpose	Instructions
1	Optional ^(a)	(RB) J4-3	(AB) J15-3	Electric Heat (IMC +)	
		(RB) J4-4	(AB) J15-4	Electric Heat (IMC -)	
		(RB) J4-3	No connect	Shield	Connect shield only at condenser to ground terminal. At air handler, tape shield back onto cable.

^(a) Required if Options Module installed for electric heat operation and/or SZVAV application.

Pairing H

Figure 9. Pairing H for condenser cooling or heat pump thermostat control applications

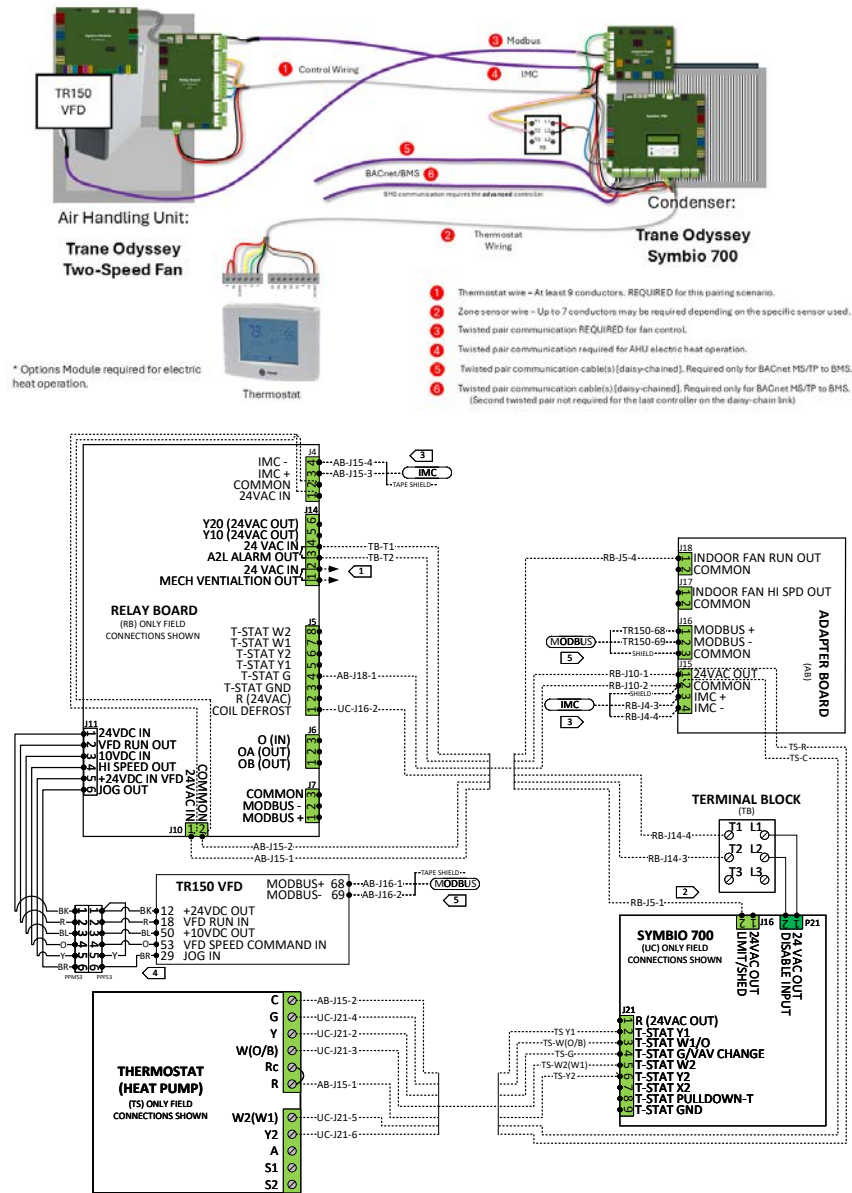

Notes:

1. Use Mechanical Ventilation Output contacts (N.O.) to enable external ventilation system when required by the application. (Contact Rating: 24VAC/VDC, 2 AMPS).
2. If EDC switch in the Symbio Air Handler unit will be utilized for low evaporator compressor protection, connection between relay board (J5-1) and Symbio 700 (J16-2) will be required. Otherwise, this connection can be omitted.
3. IMC communication wiring required for Air Handling Units equipped with electric heat.
4. To allow Equipment Shutdown input feature to override refrigerant leak mitigation actions when active. The following modifications will be required: disconnect Jog input signal, VFD terminal 29.
5. Modbus link, for supply fan control, between VFD (TR150) and the adapter board is required for full-featured functionality.

Figure 10. Pairing H for zone sensor control applications

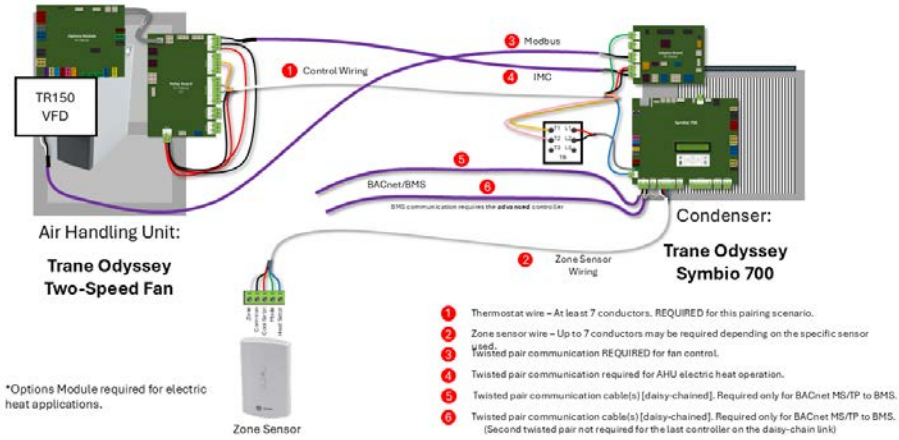

*Options Module required for electric heat applications.

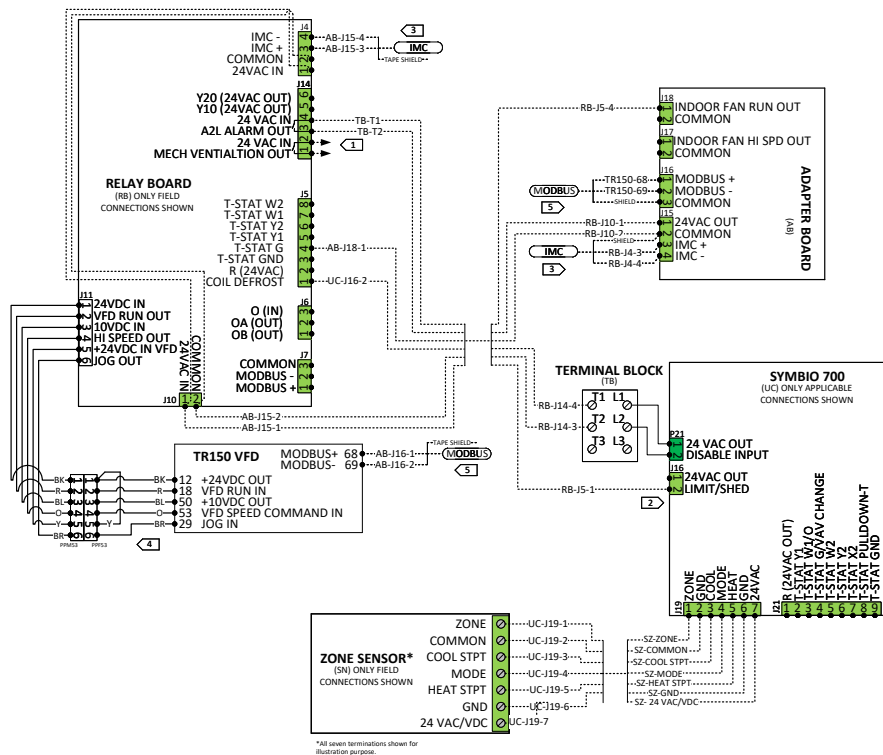

Notes:

1. Use Mechanical Ventilation Output contacts (N.O.) to enable external ventilation system when required by the application. (Contact Rating: 24VAC/VDC, 2 AMPS).
2. If EDC switch in the Symbio Air Handler unit will be utilized for low evaporator compressor protection, connection between relay board (J5-1) and Symbio 700 (J16-2) will be required. Otherwise, this connection can be omitted.
3. IMC communication wiring required for Air Handling Units equipped with electric heat.
4. To allow Equipment Shutdown input feature to override refrigerant leak mitigation actions when active. The following modifications will be required: disconnect Jog input signal, VFD terminal 29.
5. Modbus link, for supply fan control, between VFD (TR150) and the adapter board is required for full-featured functionality.

Full-Featured Functionality

Figure 11. Pairing H for Air-Fi Wireless control applications

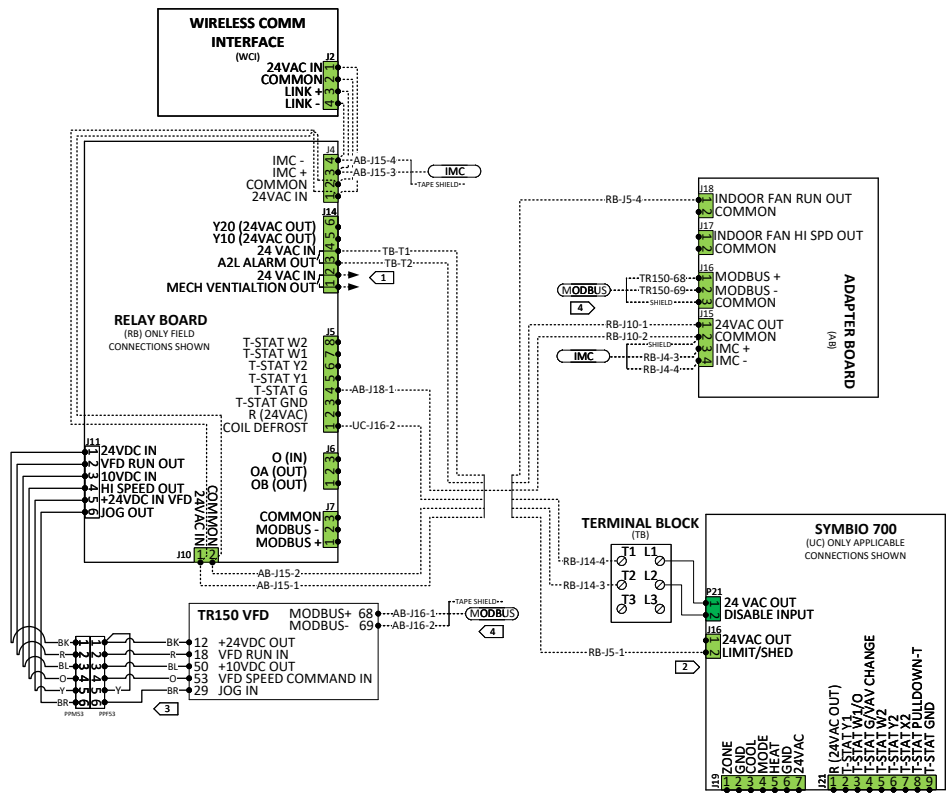
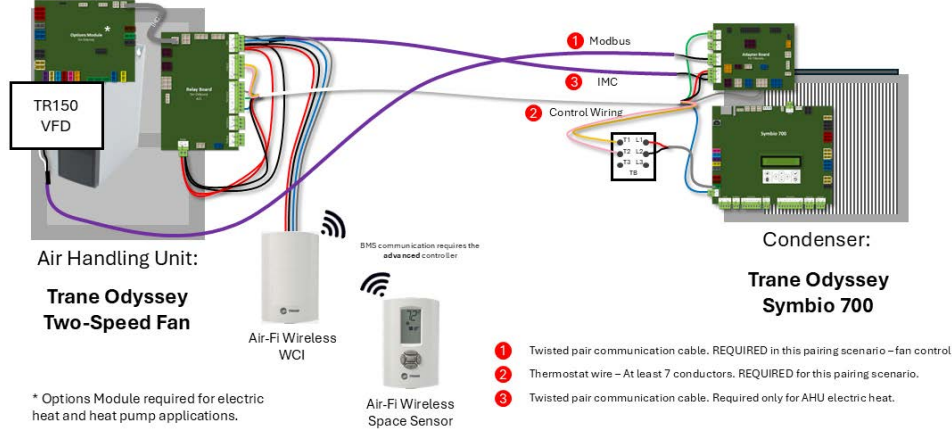

Notes:

1. Use Mechanical Ventilation Output contacts (N.O.) to enable external ventilation system when required by the application. (Contact Rating: 24VAC/VDC, 2 AMPS).
2. If EDC switch in the Symbio Air Handler unit will be utilized for low evaporator compressor protection, connection between relay board (J5-1) and Symbio 700 (J16-2) will be required. Otherwise, this connection can be omitted.
3. To allow Equipment Shutdown input feature to override refrigerant leak mitigation actions when active. The following modifications will be required: disconnect Jog input signal, VFD terminal 29.
4. Modbus link, for supply fan control, between VFD (TR150) and the adapter board is required for full-featured functionality.

Thermostat or Zone Sensor Connections

See “[Thermostat and Zone Sensor Wiring](#),” p. 19 for details on how to connect a zone sensor to J19 or thermostat to J21 on the Symbio 700 in the air handler.

See “[Symbio Service and Installation Mobile Application](#),” p. 34 for details on how to use the Symbio Service and Installation Mobile App to verify that configuration for space controller on the Symbio 700 matches the desired zone sensor or thermostat application.

Air Handler to Condenser Connections

Control wire — Thermostat style wire up to nine conductors

Table 12. Pairing H air handler to condenser wiring

Cond.	Required/ Optional	Air Handler Connection	Condenser Connection	Purpose	Instructions
1	Required	(RB) J10-1	(AB) J15-1	24VAC	It is recommended that the air handler and condensing unit share low voltage power. If the air handler and condensing unit have separate low voltage power, these conductors can be omitted, but isolation relays are needed on the remaining control wire conductors.
2	Required	(RB) J10-2	(AB) J15-2	Ground	
3	Required	(RB) J5-4	(AB) J18-1	Supply fan	Command the indoor fan to low speed.
7	Optional	(RB) J5-1	(UC) J16-2	EDC	If the EDC switch in the air handler will be utilized for low evaporator compressor protection, use the Symbio Service and Installation Mobile Application to edit the following: <ul style="list-style-type: none"> Edit Configuration: set Demand Management to Demand Limit Edit Settings: Refrigeration set Cooling Demand Limit Capacity Enable Setpoint to 0%
8	Required for A2L	(RB) J14-3	TB-T2	A2L Indication	This input is used to initiate the A2L response to disable cooling and initiate fan and ventilation sequences accordingly.
9	Required for A2L	(RB) J14-4	TB-T1	A2L Indication	

Table 13. Pairing H twisted pair cable wiring

Cable	Required/ Optional	Air Handler Connection	Condenser Connection	Purpose	Instructions
1	Optional ^(a)	(RB) J4-3	(AB) J15-3	Electric Heat and/or Air-Fi (IMC +)	
		(RB) J4-4	(AB) J15-4	Electric Heat and/or Air-Fi (IMC -)	
		(RB) J4-3	No connect	Shield	Connect shield only at condenser to ground terminal. At air handler, tape shield back onto cable.
2	Required	(RB) J7-1	(AB) J16-1	Modbus +	
		(RB) J7-2	(AB) J16-2	Modbus -	
		(RB) J7-3	No connect	Shield	Connect shield only at condenser to ground terminal. At air handler, tape shield back onto cable.

^(a) Required if Options Module installed for electric heat operation and/or SZVAV application.

Symbio 700 Configuration and Settings

See “[Symbio Service and Installation Mobile Application](#),” p. 34 for details on editing equipment configuration. Review and edit the following:

- **Indoor Fan Type:** When connecting the Symbio Condenser to a Symbio air handler with two-speed fan operation, and no Modbus communication is used. Confirm that the Symbio 700 UC indoor fan type configuration is set to “Single Speed” selection. The air handler relay board will switch the fan speeds based on the compressor operation / thermostat call.

Air Handling Unit Modifications

Confirm the following parameters in the TR150 VFD:

1. Change 3-15 from [11] Local Bus reference to [1] Analog Input 53.
2. Change 8-01 from [2] Control Word Only to [0] Digital and Control Word.

Pairing B

Figure 12. Pairing B for thermostat control applications

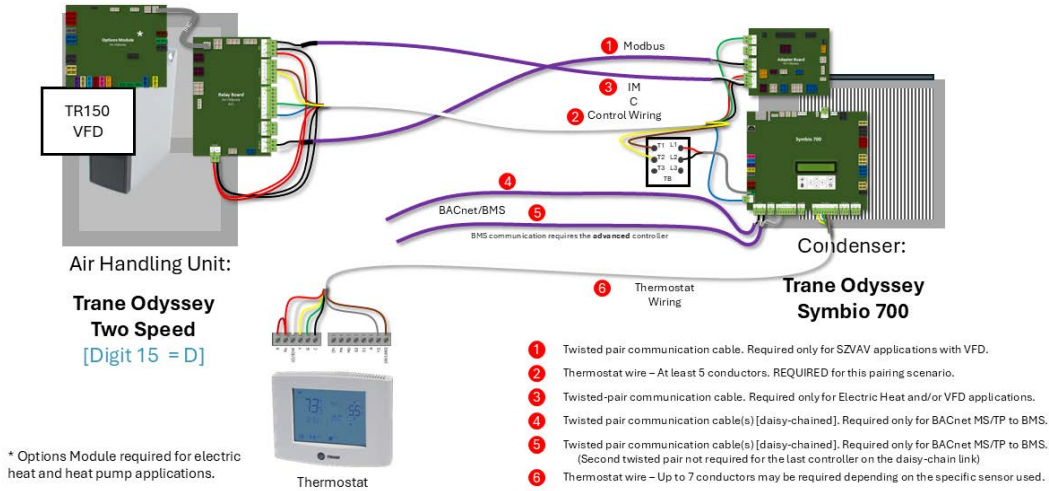

* Options Module required for electric heat and heat pump applications.

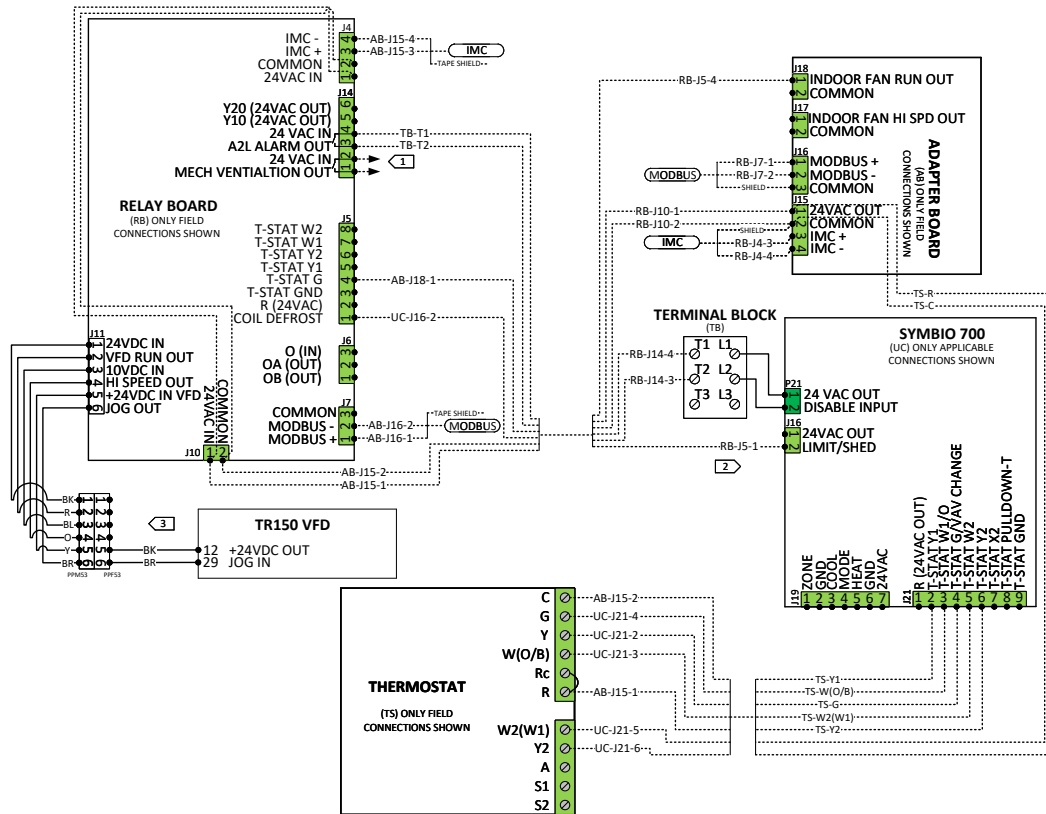

Notes:

1. Use Mechanical Ventilation Output contacts (N.O.) to enable external ventilation system when required by the application. (Contact Rating: 24VAC/VDC, 2 AMPS).
2. If EDC switch in the Symbio Air Handler unit will be utilized for low evaporator compressor protection, connection between relay board (J5-1) and Symbio 700 (J16-2) will be required. Otherwise, this connection can be omitted.
3. To allow Equipment Shutdown input feature to override refrigerant leak mitigation when active, remove factory wire harness from VFD Jog Input (PPF53 to VFD terminals 12 and 29).

Full-Featured Functionality

Figure 13. Pairing B for zone sensor control applications

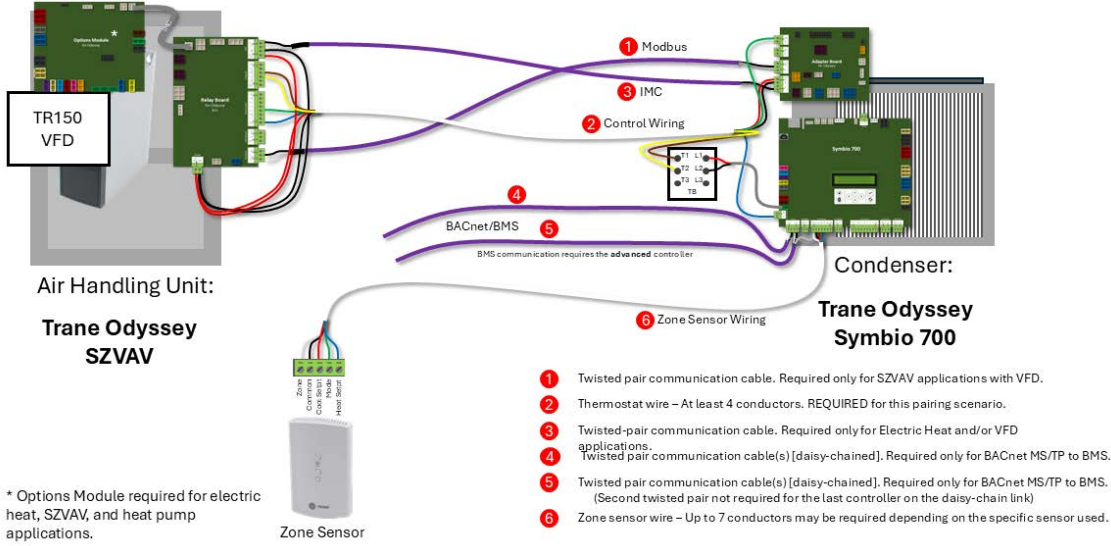

* Options Module required for electric heat, SZVAV, and heat pump applications.

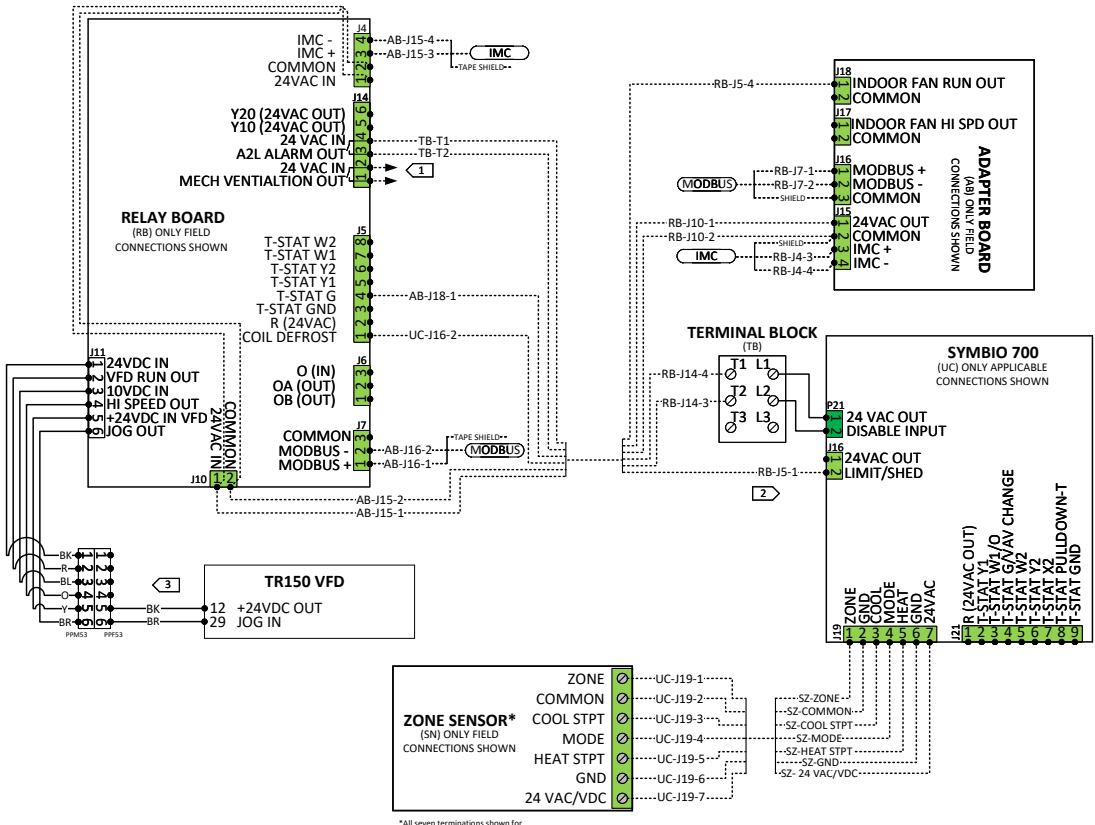

*All seven terminations shown for illustration purpose.

Notes:

1. Use Mechanical Ventilation Output contacts (N.O.) to enable external ventilation system when required by the application. (Contact Rating: 24VAC/VDC, 2 AMPS).
2. If EDC switch in the Symbio Air Handler unit will be utilized for low evaporator compressor protection, connection between relay board (J5-1) and Symbio 700 (J16-2) will be required. Otherwise, this connection can be omitted.
3. To allow Equipment Shutdown input feature to override refrigerant leak mitigation when active, remove factory wire harness from VFD Jog Input (PPF53 to VFD terminals 12 and 29).

Figure 14. Pairing B for Air-Fi Wireless control applications

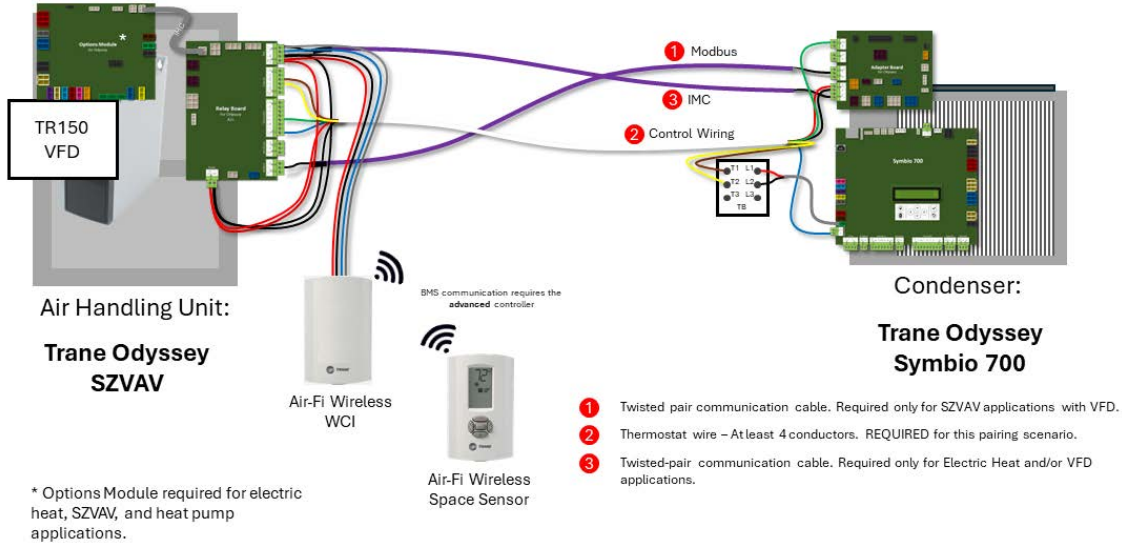

* Options Module required for electric heat, SZVAV, and heat pump applications.

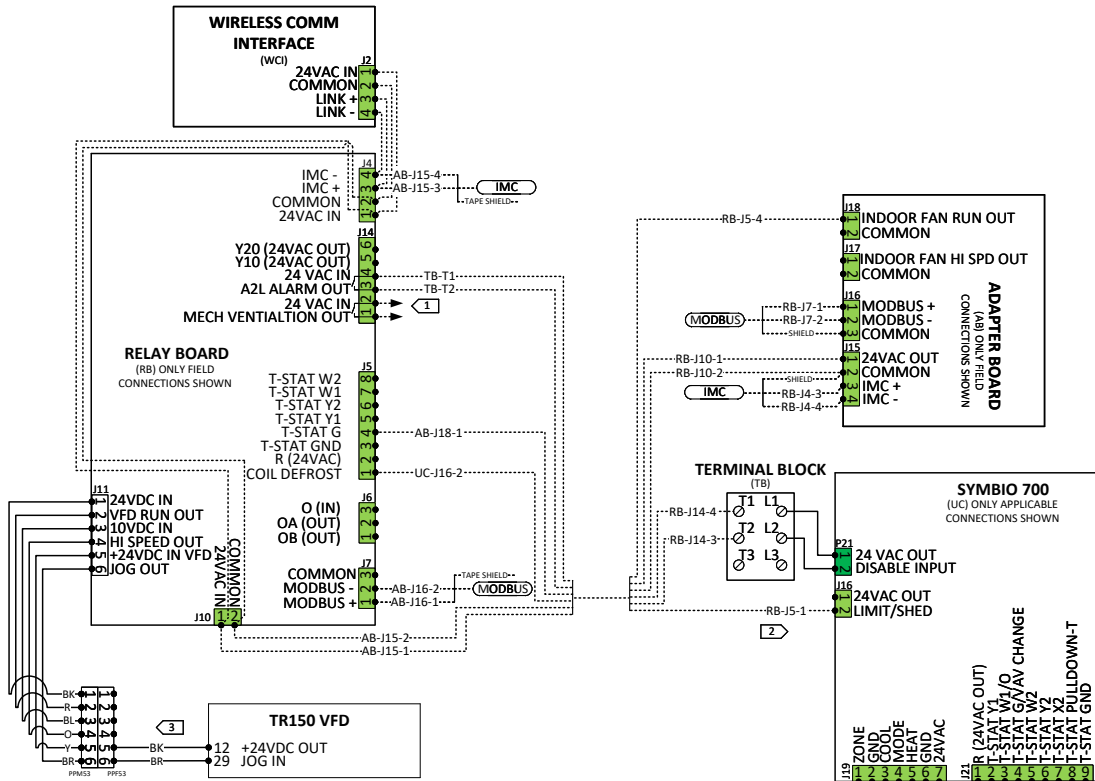

Notes:

1. Use Mechanical Ventilation Output contacts (N.O.) to enable external ventilation system when required by the application. (Contact Rating: 24VAC/VDC, 2 AMPS).
2. If EDC switch in the Symbio Air Handler unit will be utilized for low evaporator compressor protection, connection between relay board (J5-1) and Symbio 700 (J16-2) will be required. Otherwise, this connection can be omitted.
3. To allow Equipment Shutdown input feature to override refrigerant leak mitigation when active, remove factory wire harness from VFD Jog Input (PPF53 to VFD terminals 12 and 29).

Configure the Symbio 700 Controller

For applications with a zone sensor and where SZVAV or VVZT is required, use only the first configuration. For applications with a thermostat, either configuration will result in the same multi-speed manner.

For Variable Volume Zone Temperature (VVZT or formerly known as SZVAV) operation set the configuration as follows:

- System Type = **VVZT**
- Space Controller = Conventional Thermostat (not recommended for VVZT operation), Single Setpoint Zone sensor, or Dual Setpoint Zone Sensor
- Froststat = Installed
- Discharge Temperature Sensor = Installed Field installed electric heat only
- TTA condenser:
 - Primary Heating Source = Electric
 - Primary Heating Stages = 1 or 2 (depending on electric heat kit stages)
- TWA condenser:
 - Secondary Heating Source = Electric
 - Secondary Heating Stages = 1 or 2 (depending on electric heat kit stages)

For Multi-speed fan operation set the configuration as follows:

- System Type = **CVZT**
- Indoor Fan Type = Multi Speed
- Space Controller = Conventional Thermostat, Single Setpoint Zone sensor, or Dual Setpoint Zone Sensor
- Froststat = Installed
- Discharge Temperature Sensor = Installed or not installed
- Field installed electric heat only
- TTA condenser:
 - Primary Heating Source = Electric
 - Primary Heating Stages = 1 or 2 (depending on electric heat kit stages)
- TWA condenser:
 - Secondary Heating Source = Electric
 - Secondary Heating Stages = 1 or 2 (depending on electric heat kit stages)

Zone Sensor or Thermostat Connections

See [“Thermostat and Zone Sensor Wiring,” p. 19](#) for details on how to connect a zone sensor to J19 or thermostat to J21 on the Symbio 700 in the air handler. For SZVAV applications a space temperature sensor is required. Using a thermostat on a SZVAV air handler will result in two speed fan operation.

See [“Symbio Service and Installation Mobile Application,” p. 34](#) for details on how to use the Symbio Service and Installation Mobile App to verify that configuration for space controller on the Symbio 700 matches the desired zone sensor or thermostat application.

Air Handler to Condenser Connections

Control Wire — Thermostat style wire up to six conductors

Table 14. Pairing B air handler to condenser wiring

Cond.	Required /Optional	Air Handler Connection	Condenser Connection	Purpose	Instructions
1	Required	(RB) J10-1	(AB) J15-1	24VAC	It is recommended that the air handler and condensing unit share low voltage power. If the air handler and condensing unit have separate low voltage power, these conductors can be omitted, but isolation relays are needed on the remaining control wire conductors.
2	Required	(RB) J10-2	(AB) J15-2	Ground	
3	Required	(RB) J5-4	(AB) J18-1	Supply fan	Command the constant volume indoor fan to run or will interlock a variable speed fan with the electric heat.
4	Optional	(RB) J5-1	(UC) J16-2	EDC	This conductor is optional and is only needed if compressor protection at low evaporator temperatures is desired. Reference page 28 for details on how to use the Symbio Service and Installation Mobile Application to set the configuration for Demand Management to Demand Limit, and in Settings change Cooling Demand Limit Capacity Enable Setpoint to 0%.
5	Required for A2L	(RB) J14-3	TB-T2	A2L Indication	This input is used to initiate the A2L response to disable cooling and initiate fan and ventilation sequences accordingly.
6	Required for A2L	(RB) J14-4	TB-T1	A2L Indication	

Shielded Twisted Pair Cable — up to two cables

Table 15. Pairing B twisted pair cable wiring

Cable	Required/ Optional	Air Handler Connection	Condenser Connection	Purpose	Instructions
1	Required	(RB) J4-3	(AB) J15-3	Electric Heat and/or VFD (IMC +)	
		(RB) J4-4	(AB) J15-4	Electric Heat and/or VFD (IMC -)	
		(RB) J4-3	No connect	Shield	Connect shield only at condenser to ground terminal. At air handler, tape shield back onto cable.
2	Required	(RB) J7-1	(AB) J15-3	Modbus+	
		(RB) J7-2	(AB) J15-4	Modbus-	
		(RB) J7-3	No connect	Shield	Connect shield only at condenser to ground terminal. At air handler, tape shield back onto cable.

Symbio Service and Installation Mobile Application

The Symbio Service and Installation mobile app provides advanced configuration, setup, status updates, alarms, and service capabilities for the Symbio 700 controller via Bluetooth connection.

The Symbio 700 can connect to mobile devices that support BLE version 4.2 and higher. Only one connection is allowed at a time to prevent another user from connecting to the system while it is already in use. If a connection is lost, whether accidental or purposeful, a timer is used to prevent the controller from being locked by a user that does not disconnect the controller in a preferred manner.

The Symbio Installation and Service tool is required to view and edit the following:

- Equipment configuration
- Historical alarms
- Firmware updates
- Backup and restore
- Building Automation System configuration

For more detailed information on the Symbio Service and Installation Mobile Application, refer to the Quick Start Guide for Symbio Service and Installation - BAS-SVN043*-EN.

Download Mobile App

To download the Symbio Service & Installation mobile app:

1. Access the Apple App Store or Google Play store by scanning the QR code below or clicking one of the download links.



- [Apple download link](#)
 - [Google Play \(Android\) download link](#)
2. Navigate to the Apple App Store or Google Play Store on your mobile device.
 3. Search for **Trane Symbio** to locate the Symbio Service & Installation app.
 4. Download and install the app.

Figure 15. Symbio Service & Installation app



Connecting to the Symbio 700

Required Tools

- 5/16 inch nut driver tool for panel removal

- Smart devices supported:
 - iPhone®
 - Android™
- Trane Symbio Service Installation mobile app

Connecting to the Symbio 700 Controller

1. Enable **Bluetooth®** on your smart device.
2. Access the Symbio™ 700 controller in the low voltage portion of the equipment.

Figure 16. Symbio 700 controller

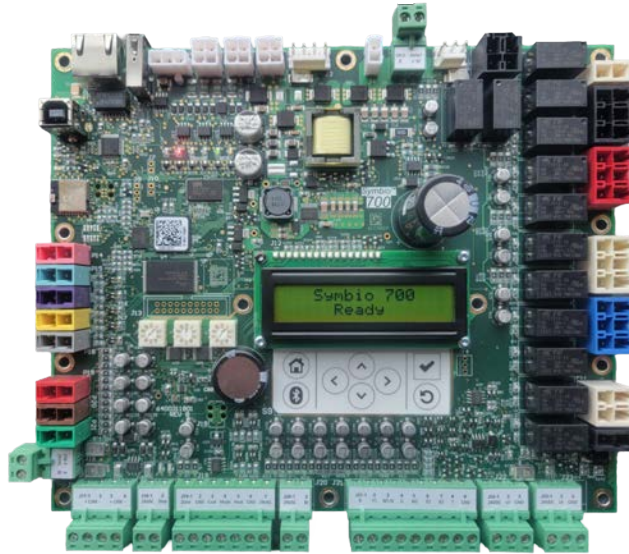

3. Press  on the Symbio 700 keyboard/display to turn on Bluetooth.
4. Confirm the status of Bluetooth communications.

	Blue LED	Display	Description
Press for On/Off	Off	NOT CONNECTED	Bluetooth Off
	Blinking	WAITING...	Bluetooth On — Not Paired
	On Solid	CONNECTED	Bluetooth On — Connected/ Paired

¹ The Bluetooth® word mark and logos are registered trademarks owned by Bluetooth SIG, Inc. and any use of such marks by the company is under license.

Figure 17. Symbio 700 Bluetooth status

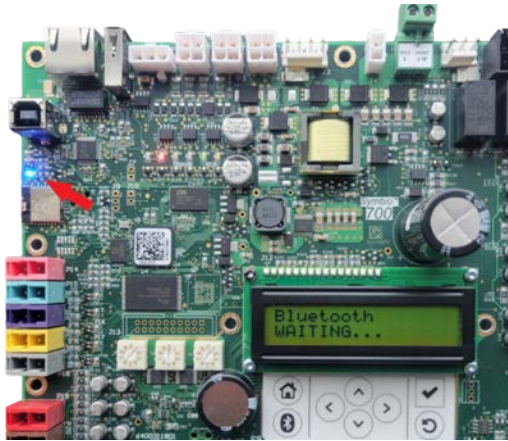

5. Start the mobile app on your smart device.

Figure 18. Login screen

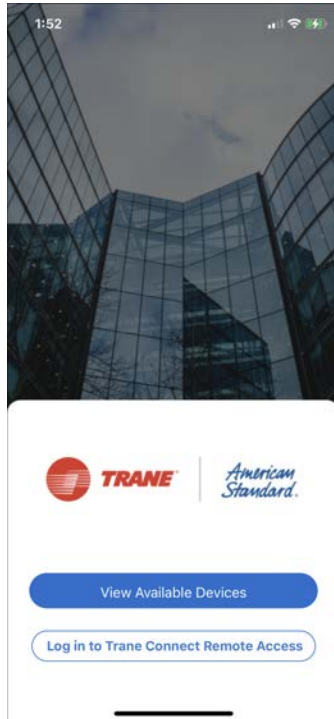



6. On the login screen, press **View Available Devices** in the lower portion of the screen. Or Trane personnel can login using their Trane Connect user name and password.
7. On the Unit List page, select the Symbio 700 controller to pair with. If the controller is not listed, press the refresh arrow in the upper right-hand corner of the screen.

Note: *If a Symbio 700 is not the original Symbio controller as shipped with the equipment, the Bluetooth equipment list will list the controller serial number, instead of the equipment serial number.*

8. When prompted, pair the app to the Symbio 700 controller. A popup message displays a 6-digit random number. The same number is shown on the display of the Symbio 700 controller until the pairing is complete, allowing the user to confirm connection to the intended controller.

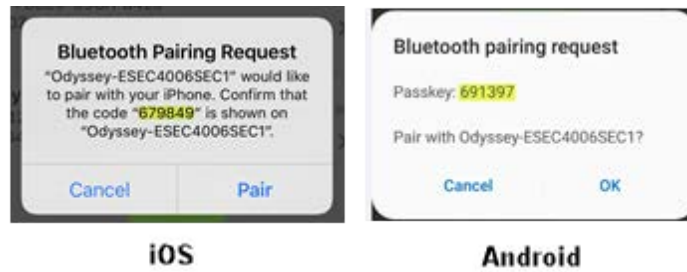
Figure 19. Bluetooth pairing



9. Press  on the Symbio 700 on-board keyboard/display to complete the pairing.

When the LED light is a solid blue and the display reads Bluetooth Connected, the Bluetooth pairing and connection is complete.

Troubleshooting

Issue	Description
Smart device requirements not met	<ul style="list-style-type: none"> Apple iPhone (iOS V10; iPhone 6 or later required) Android (V5.0 Lollipop or later; a device with Bluetooth V4.2 or later required) <p><i>Note: It is not possible to check what Bluetooth connectivity version is installed on an Android device, as it does not appear in Settings.</i></p>
Multiple users attempting to connect to the controller via Bluetooth	Only one user can connect to the Symbio 700 controller via Bluetooth. If the blue light is solid, another user is connected to the controller.
Device outside of Bluetooth range limits	Bluetooth has physical range limitations. A user can lose connectivity if too far away from the controller and will need to re-access connectivity from the Units List page.
Exceeded limit of equipment pairings	The app only allows 10 saved pairings per device. Android devices will auto delete the oldest pairing. If auto delete fails, you can manually delete pairings. iOS users must manually delete pairings through Settings.
Smart device unpaired or disconnected from controller	<ul style="list-style-type: none"> Pressing the Bluetooth button on the controller while connected will disconnect the controller from the smart device. Cycling power to the controller, a firmware update, or a restore/start controller will disconnect the Bluetooth connection. Equipment shutdown will disconnect the Bluetooth connection.

Navigation

The Symbio Service & Installation app allows users to view and edit equipment settings. Each page is represented by an icon at the bottom of the screen.

Symbio Service and Installation Mobile Application

Home

On the home screen, select the tools icon at the bottom of the screen to navigate to the **Settings** screen.

Figure 20. Home screen

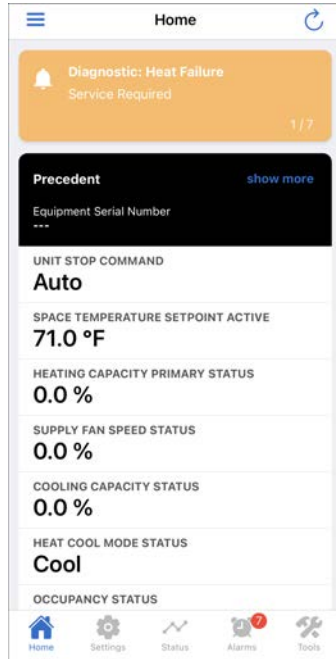

Settings

The Settings screen allows users to set up equipment. Users can set the default value for many setpoints and modes. Edit any setting by selecting the blue text.

Figure 21. Settings screen

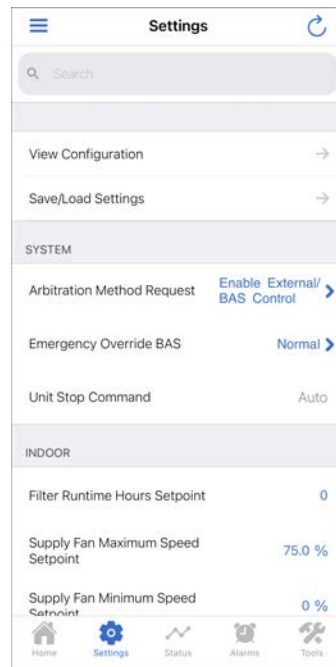

Status

The Status screen displays all information available in the Symbio 700. Some information can be overridden by selecting the blue text.

Figure 22. Status screen

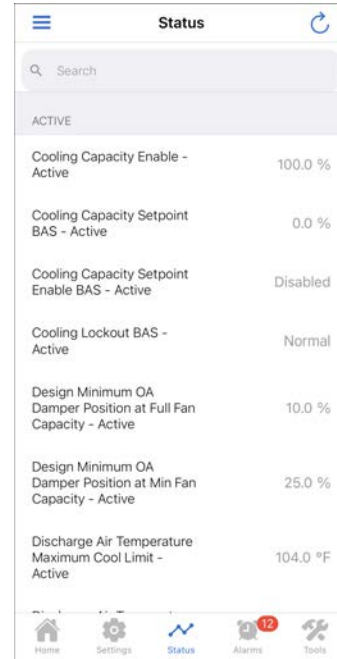

Alarms

The Alarms screen displays all active and historic BACnet alarms that are available on the equipment.

Figure 23. Alarms screen

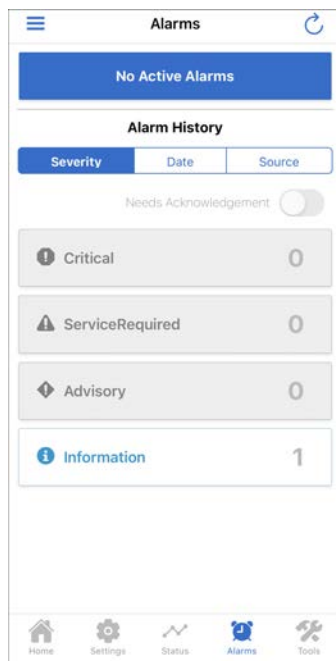

Tools

The Tools screen provides access to common procedures for the equipment.

Figure 24. Tools screen

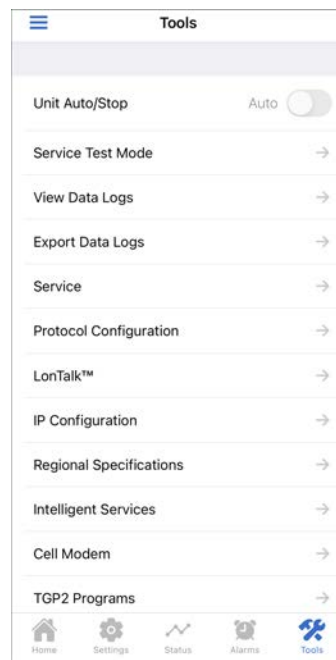

Editing Equipment Configuration

Depending on how the split system condenser and air handler are paired, adjusting the equipment configuration may be required for proper operation. To edit the equipment configuration:

1. On the home screen, select the tools icon at the bottom of the screen to navigate to the **Settings** screen.

Figure 25. Home screen

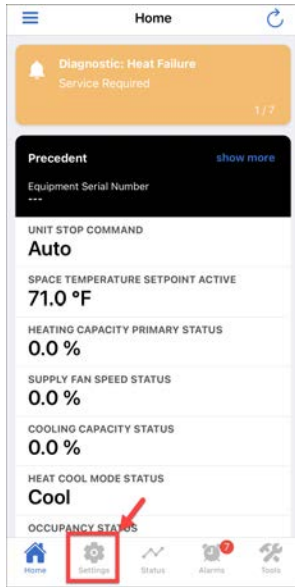

2. Select **View Configuration**.

Figure 26. View configuration screen

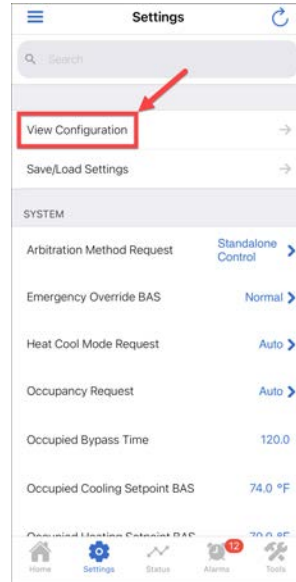

3. Select **Edit**.

Figure 27. Edit configuration screen



4. The equipment must be stopped to edit the configuration. Press **Proceed** to stop the equipment.

Figure 28. Stopping the equipment screen

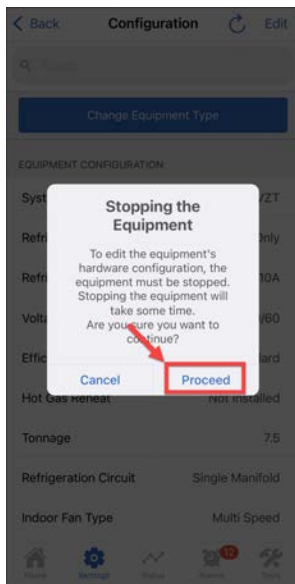

5. On the **Edit** screen, scroll to the option that needs to be edited. To edit an option, select the option.

Figure 29. Edit configuration screen

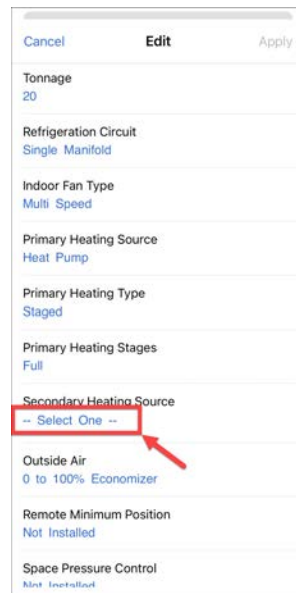

6. Select the desired option. Then select **Apply** to save the setting change.

Figure 30. Edit configuration screen

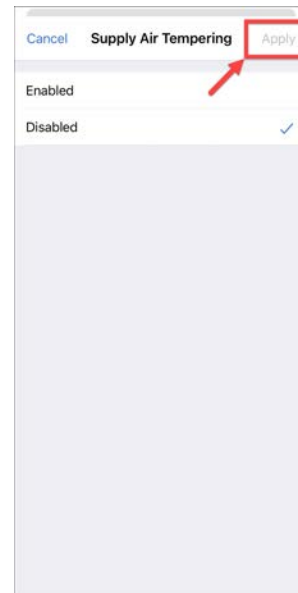

Viewing Alarms

To verify proper equipment operation and to help troubleshoot, the Symbio Service & Installation app allows users to view equipment alarms. Depending how the Symbio 700 is licensed, these views may be slightly different from what is shown.

1. On the Home screen, swipe left or right at the top of the page to view active alarms.
2. Select the Alarm icon to view more information on historical and active alarms.
3. Tap to sort the Alarm history by Severity, Date, or Source.

Figure 31. Home screen

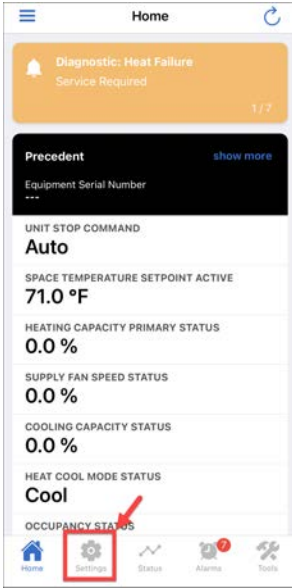

Figure 32. Home screen

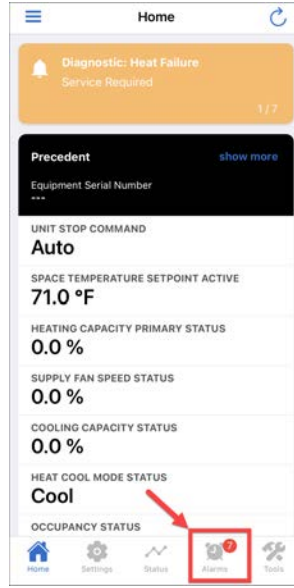
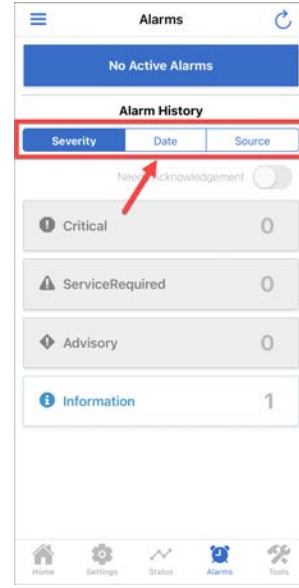
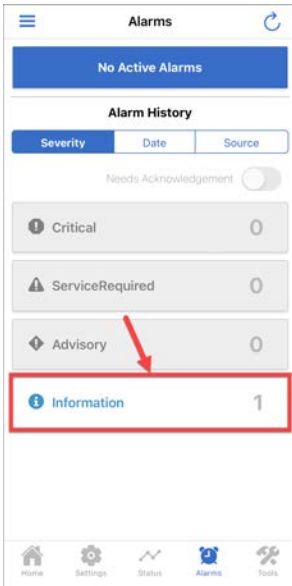

Figure 33. Alarm history screen



4. Select a group to view more details about the historical alarms.

Figure 34. Alarm history screen



5. Select the Active alarms button to view more details about active alarms on the equipment.

Figure 35. Active alarms screen

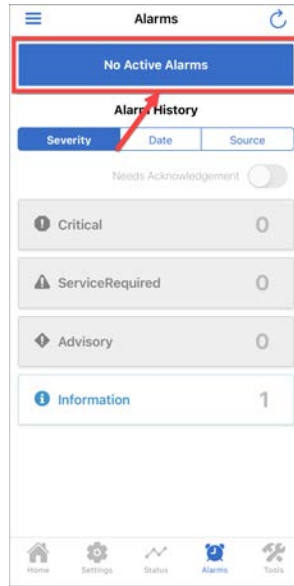

Service Test Mode

Service Test Mode provides the ability to energize the various components of the system, either to support general system startup tasks or to support troubleshooting. Below are the steps to initiate Service Test Mode. For detailed information on how each Service Test State is interpreted based on the equipment configuration, refer to the Symbio 700 Odyssey Controls Application Guide (ACC-APG001*-EN).

1. On the home screen, select the tools icon at the bottom of the screen to navigate to the **Settings** screen.

Figure 36. Home screen

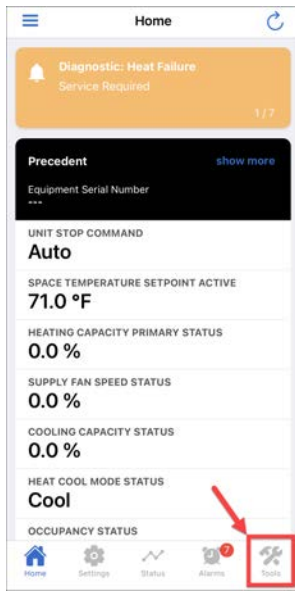

2. Select **Service Test Mode**.

Figure 37. Tools screen

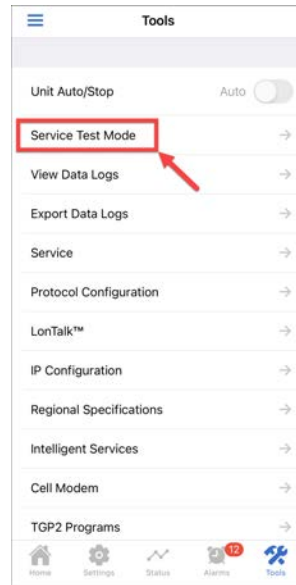

3. Select any of the blue play icons to initiate that test mode.

Figure 38. Service test mode screen

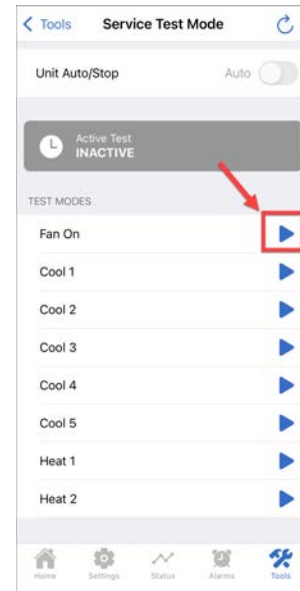

4. When a test is active, the status indicates active test mode.

Figure 39. Active service test mode screen

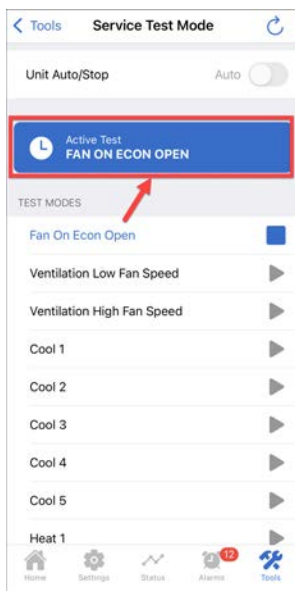

5. To exist Service Test Mode, click the stop icon next to the active test mode. Active test modes time out after the Service Test Timeout timer (60 minutes default) expires or power is cycled to the controller.

Figure 40. Active service test mode screen

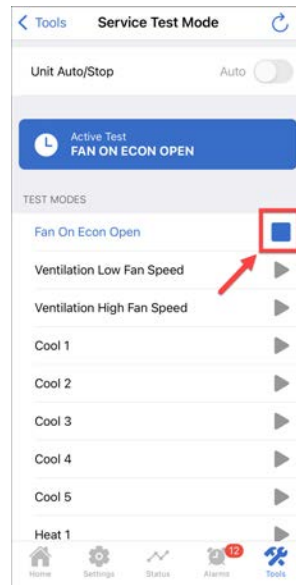

Symbio 700 User Interface

The Symbio 700 controller provides a 2 X 16 backlit LCD display on the middle of the controller. The onboard user interface includes a Bluetooth pair button to pair with the Symbio 700 controller for use with the Symbio Service & Installation mobile app.

Figure 41. User interface keypad

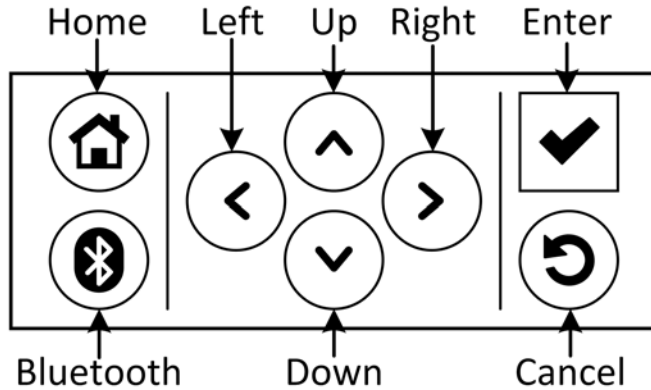





Table 16. User interface buttons

Button	Description
Up/down	Allow the user to scroll the menus and submenus.
Left/right	Allow the user to scroll between values for editable items.
	<ul style="list-style-type: none"> Allows user to drill down into a component of the menu tree. Confirm data changes on writable data. When data is editable, the data point's least significant digit flashes with a cursor. If the data has multiple editable digits, the user scrolls the cursor left and right to choose the editable digit. Once the editing is complete, the data is not changed and propagated through the controller until the Enter button is tapped.
	Tap to exit all submenus and return to the Home screen.
	Tap to go to the Bluetooth menu and initiate the Bluetooth device pairing sequence.
	Tap to return to the previous menu level.

The interface provides an intuitive menu structure: alarms, status, service, settings, and utilities. Configuration of the unit is accomplished under the utilities menu item. A complete list of functions is outlined in the Symbio 700 User Guide - BAS-SVU054*-EN.

Figure 42. Symbio 700 menu

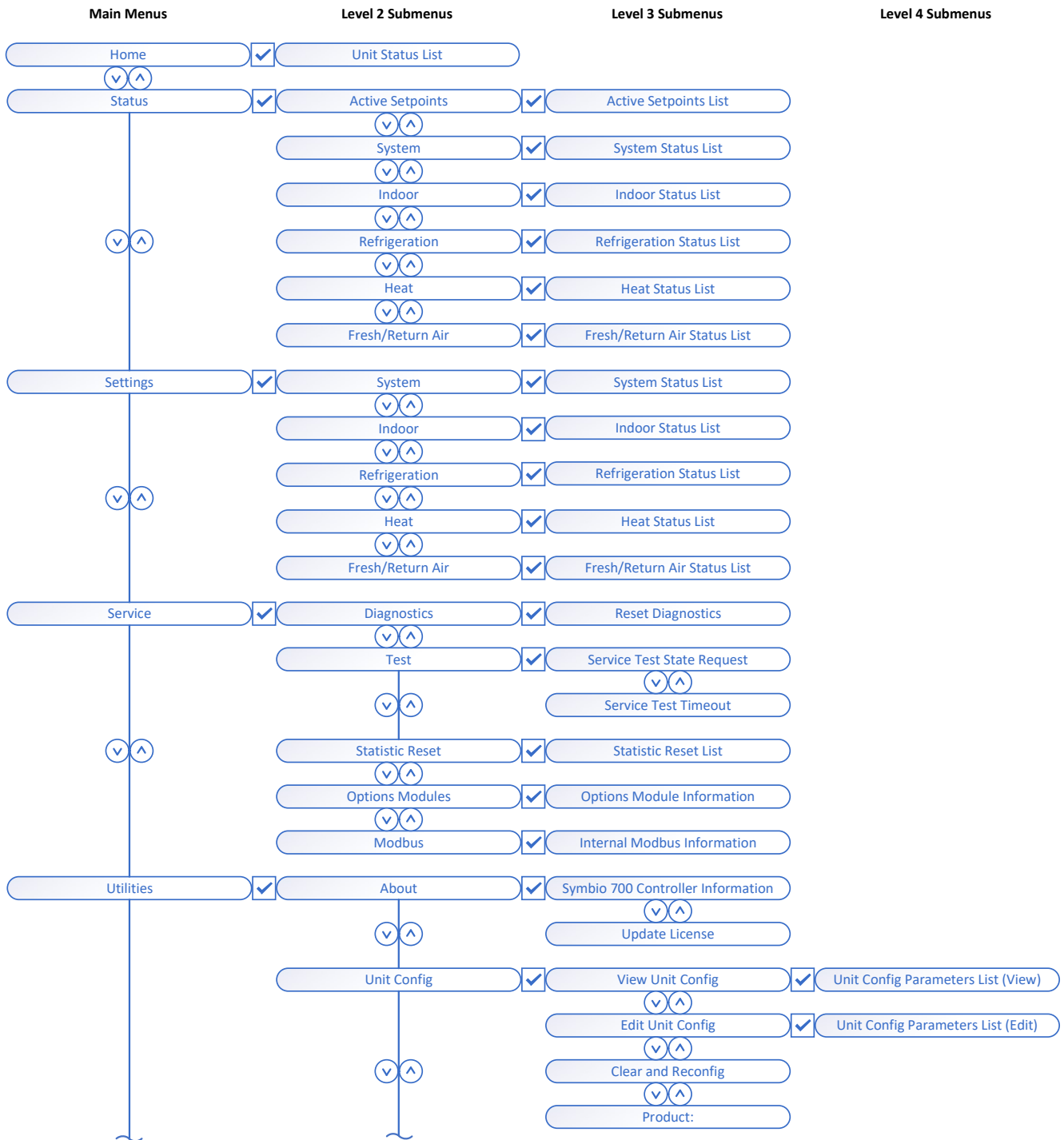
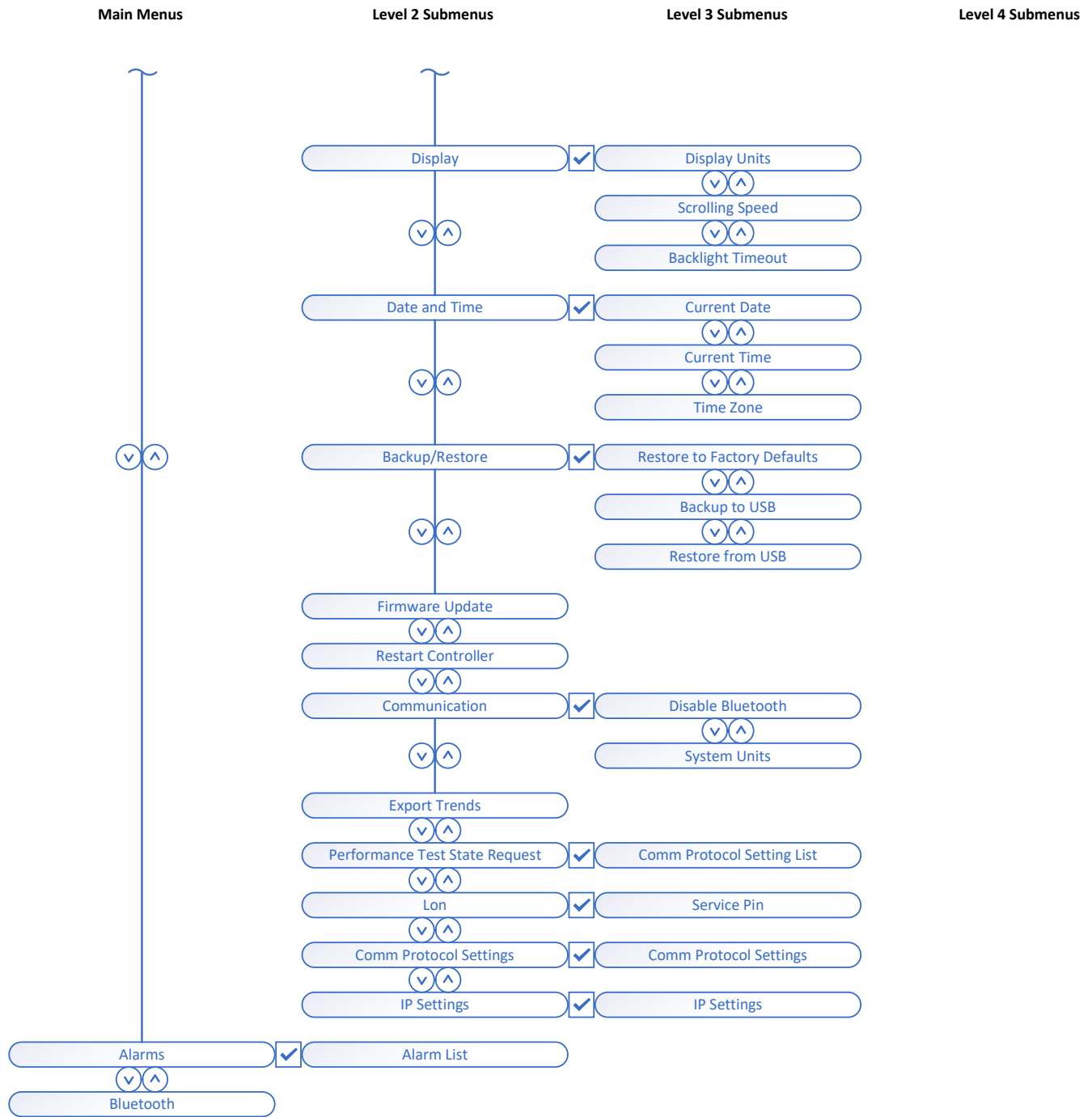

Figure 43. Symbio 700 menu (continued)



Editing Equipment Configuration

To edit the configuration of the equipment using the onboard display navigate to the **Edit Configuration Settings** submenu. The figure below shows the path to the edit configuration submenu. Use the enter button to advance to submenus and the up and down arrow buttons to scroll through menus.

Figure 44. Symbio 700 utilities menu

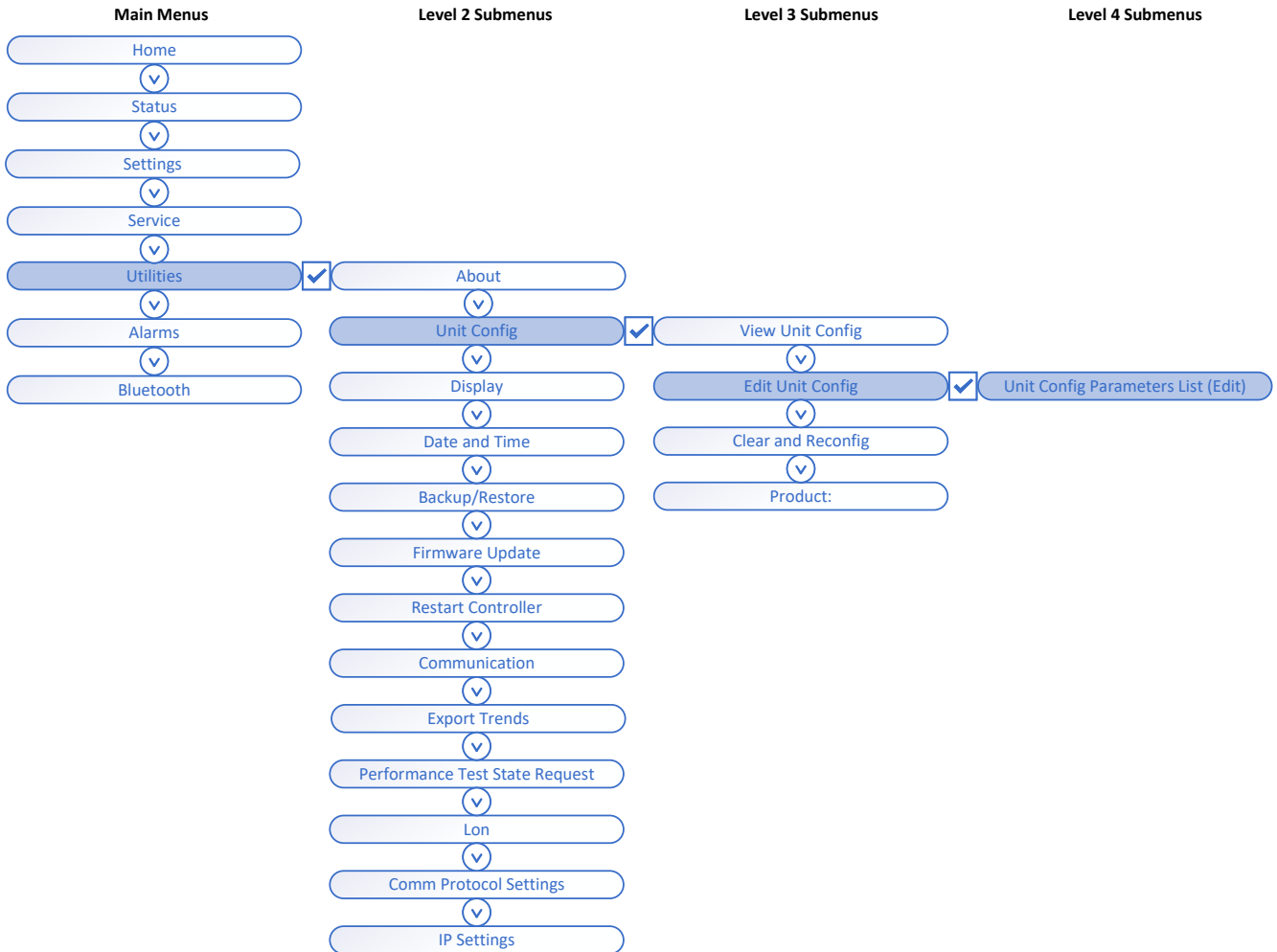

Viewing Alarms

To view equipment alarms using the onboard display navigate to the Alarm List submenu. The figure below shows the path to the Alarm List submenu. Use the enter button to advance to submenus and the up and down arrow buttons to scroll through menus.

Figure 45. Symbio 700 alarms menu

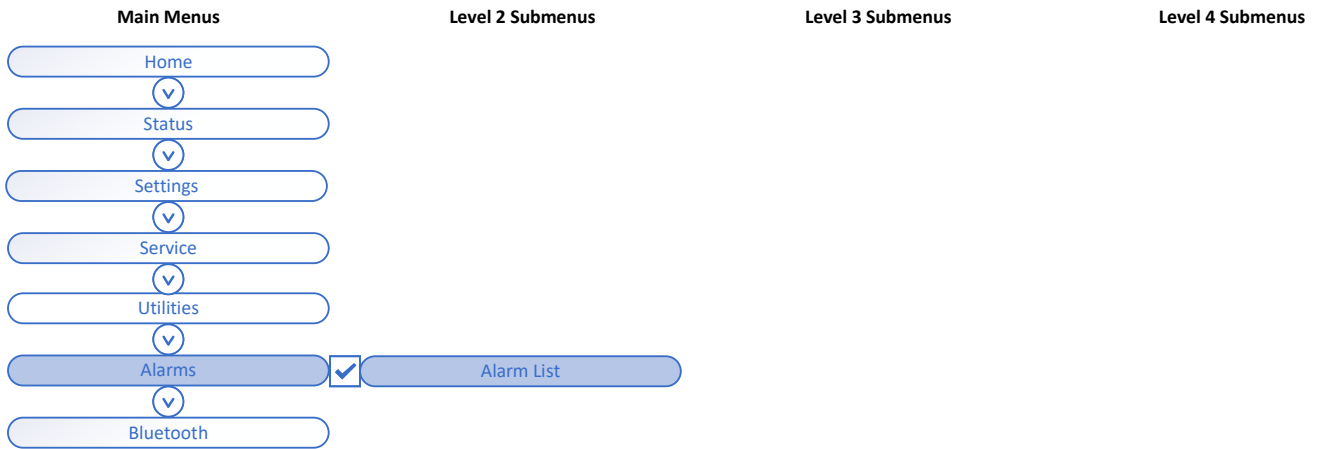

Service Test Mode

To put the equipment into Service Test Mode, use the onboard display navigate to the Test Modes submenu. The figure below shows the path to the Test Modes submenu. Use the enter button to advance to submenus and the up and down arrow buttons to scroll through menus.

Figure 46. Symbio 700 service test mode menu

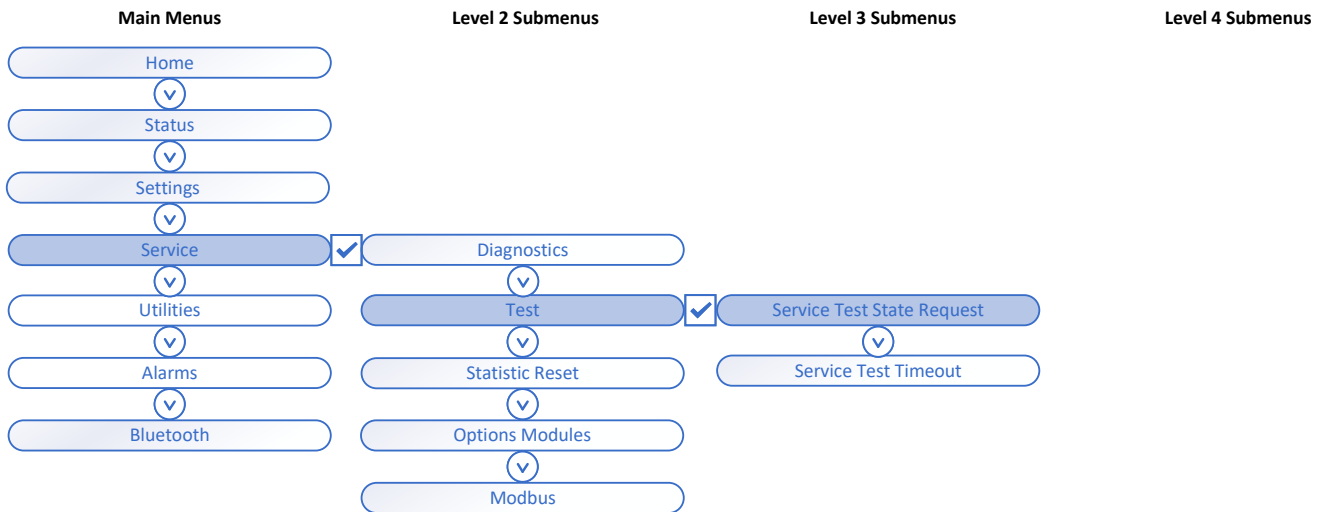

More Information and Technical Support

Trane Light Commercial Help Center



Trane Split Systems



Trane and American Standard create comfortable, energy efficient indoor environments for commercial and residential applications. For more information, please visit trane.com or americanstandardair.com.

Trane and American Standard have a policy of continuous product and product data improvement and reserve the right to change design and specifications without notice. We are committed to using environmentally conscious print practices.

SS-SVN017B-EN 18 Oct 2024
Supersedes SS-SVN017A-EN (June 2024)

©2024