



## Installation Instructions

# AFDW Retrofit Air-Cooled Adaptive Frequency Drive™

For Use with RTAC Chillers with Symbio™ controls



Model Number: RTAC

This document applies to service offering applications only.

### **⚠ SAFETY WARNING**

Only qualified personnel should install and service the equipment. The installation, starting up, and servicing of heating, ventilating, and air-conditioning equipment can be hazardous and requires specific knowledge and training. Improperly installed, adjusted or altered equipment by an unqualified person could result in death or serious injury. When working on the equipment, observe all precautions in the literature and on the tags, stickers, and labels that are attached to the equipment.



# Introduction

Read this manual thoroughly before operating or servicing this unit.

## Warnings, Cautions, and Notices

Safety advisories appear throughout this manual as required. Your personal safety and the proper operation of this machine depend upon the strict observance of these precautions.

The three types of advisories are defined as follows:

- WARNING** Indicates a potentially hazardous situation which, if not avoided, could result in death or serious injury.
- CAUTION** Indicates a potentially hazardous situation which, if not avoided, could result in minor or moderate injury. It could also be used to alert against unsafe practices.
- NOTICE** Indicates a situation that could result in equipment or property-damage only accidents.

## Important Environmental Concerns

Scientific research has shown that certain man-made chemicals can affect the earth's naturally occurring stratospheric ozone layer when released to the atmosphere. In particular, several of the identified chemicals that may affect the ozone layer are refrigerants that contain Chlorine, Fluorine and Carbon (CFCs) and those containing Hydrogen, Chlorine, Fluorine and Carbon (HCFCs). Not all refrigerants containing these compounds have the same potential impact to the environment. Trane advocates the responsible handling of all refrigerants.

## Important Responsible Refrigerant Practices

Trane believes that responsible refrigerant practices are important to the environment, our customers, and the air conditioning industry. All technicians who handle refrigerants must be certified according to local rules. For the USA, the Federal Clean Air Act (Section 608) sets forth the requirements for handling, reclaiming, recovering and recycling of certain refrigerants and the equipment that is used in these service procedures. In addition, some states or municipalities may have additional requirements that must also be adhered to for responsible management of refrigerants. Know the applicable laws and follow them.

**WARNING**

**Proper Field Wiring and Grounding Required!**

Failure to follow code could result in death or serious injury. All field wiring **MUST** be performed by qualified personnel. Improperly installed and grounded field wiring poses **FIRE** and **ELECTROCUTION** hazards. To avoid these hazards, you **MUST** follow requirements for field wiring installation and grounding as described in **NEC** and your local/state/national electrical codes.

**WARNING**

**Personal Protective Equipment (PPE) Required!**

Failure to wear proper PPE for the job being undertaken could result in death or serious injury. Technicians, in order to protect themselves from potential electrical, mechanical, and chemical hazards, **MUST** follow precautions in this manual and on the tags, stickers, and labels, as well as the instructions below:

- Before installing/servicing this unit, technicians **MUST** put on all PPE required for the work being undertaken (Examples; cut resistant gloves/sleeves, butyl gloves, safety glasses, hard hat/bump cap, fall protection, electrical PPE and arc flash clothing). **ALWAYS** refer to appropriate Safety Data Sheets (SDS) and OSHA guidelines for proper PPE.
- When working with or around hazardous chemicals, **ALWAYS** refer to the appropriate SDS and OSHA/GHS (Global Harmonized System of Classification and Labeling of Chemicals) guidelines for information on allowable personal exposure levels, proper respiratory protection and handling instructions.
- If there is a risk of energized electrical contact, arc, or flash, technicians **MUST** put on all PPE in accordance with OSHA, NFPA 70E, or other country-specific requirements for arc flash protection, **PRIOR** to servicing the unit. **NEVER PERFORM ANY SWITCHING, DISCONNECTING, OR VOLTAGE TESTING WITHOUT PROPER ELECTRICAL PPE AND ARC FLASH CLOTHING. ENSURE ELECTRICAL METERS AND EQUIPMENT ARE PROPERLY RATED FOR INTENDED VOLTAGE.**

**⚠ WARNING****Follow EHS Policies!**

Failure to follow instructions below could result in death or serious injury.

- All Trane personnel must follow the company's Environmental, Health and Safety (EHS) policies when performing work such as hot work, electrical, fall protection, lockout/tagout, refrigerant handling, etc. Where local regulations are more stringent than these policies, those regulations supersede these policies.
- Non-Trane personnel should always follow local regulations.

**⚠ WARNING****Conform to All Applicable National, State, and Local Electrical Codes!**

Failure to follow all applicable codes could result in an arc flash event, electrocution, explosion, or fire, which could result in death or serious injury.

Users **MUST** conform to all applicable national, state, and local electrical codes during the electrical installation and servicing of this product.

**⚠ WARNING****Refrigerant under High Pressure!**

Failure to follow instructions below could result in an explosion which could result in death or serious injury or equipment damage. System contains refrigerant under high pressure.

Recover refrigerant to relieve pressure before opening the system. See unit nameplate for refrigerant type. Do not use non-approved refrigerants, refrigerant substitutes, or refrigerant additives.

**⚠ WARNING****Hazardous Voltage w/Capacitors!**

Failure to disconnect power and discharge capacitors before servicing could result in death or serious injury. Disconnect all electric power, including remote disconnects and discharge all motor start/run capacitors before servicing. Follow proper lockout/tagout procedures to ensure the power cannot be inadvertently energized. For variable frequency drives or other energy storing components provided by Trane or others, refer to the appropriate manufacturer's literature for allowable waiting periods for discharge of capacitors. Verify with a CAT III or IV voltmeter rated per NFPA 70E that all capacitors have discharged.

**NOTICE****Excessive Cable Lengths Between AFDW Drive and Compressor Motor!**

Trane assumes no responsibility for equipment damage caused by use of improper cable lengths. The variable frequency drive industry recommends that the length of the electrical cables connecting a drive unit to a motor should be kept to less than 250 feet to protect the motor from reflected voltage waves that can cause the motor to fail. Cable lengths that exceed 250 feet between the drive and the motor create the potential for damage to occur to the motor windings and/or insulation.

**Copyright**

This document and the information in it are the property of Trane, and may not be used or reproduced in whole or in part without written permission. Trane reserves the right to revise this publication at any time, and to make changes to its content without obligation to notify any person of such revision or change.

**Trademarks**

All trademarks referenced in this document are the trademarks of their respective owners.



# Table of Contents

General Information	5	Installation – Electrical	28
Other Required Manuals	5	Electrical Connections	28
Model Number Descriptions	6	RTAC Panel Wiring (Circuit 1 or 2)	28
Environmental Conditions	7	AFD Enclosure Wiring	30
Nameplates	8	Compressor Wiring	32
Output Current	8	Control Wiring	33
Dimensions	9	Symbio 800 Software Installation and Configuration	38
Unit Submittal Drawings	9	Drive Settings	40
Pre-Installation	10	Retrofit Air-Cooled RTAC	
Required Tools	10	Adaptive Frequency Drive Model	
Parts	10	AFDW (TR200)	40
AFD Sizing	13	Installation and Start-Up	40
Global Connector Harnesses	14	Chiller Setting Logs	42
Required Parts – Not Supplied	15	Start-Up Test Log	42
Preparation in DynaView™	15	Operator Log	43
Check the Configuration and Setpoints in the DynaView Display	15	Troubleshooting	45
DynaView Configuration and Setpoints	15	Recommended Annual Maintenance and Inspection	46
Oil and Refrigerant Removal	17	Visual Inspection — Power Removed	46
Procedure for Circuits with Two Compressors	17	Operational Inspection — Power Applied	46
Component Location	18	Wiring Information	47
Installation	21	Wiring Diagram Matrix	47
Shutdown Power	21	Field Wiring	48
RTAC Symbio 800 Controls Upgrade	21		
Important Note on Panel Configuration Variations	21		
AFDW Kit Options	21		
Panel Component Installation	21		
Installing Enclosure and Drive	21		
Rigging and Lifting Procedures for AFDW Drive Units	24		
Unit Lifting Points – Preferred Lifting Method	25		
Unit Lifting Points – Alternative Lifting Method	25		
Drive Installation	25		
Block Off Plate Installation	26		
Weather Proofing Enclosure	27		



## General Information

**Important:** *The combination of Symbio™ controls on RTAC chillers with AFDW do not support the use of a UPS on the chiller controls.*

This manual describes installation of an AFDW retrofit air-cooled Adaptive Frequency Drive™ package in place of an existing starter on a Trane RTAC helical rotary liquid chiller with Tracer® UC800 and Symbio 800 controllers. If the chiller has a CH530 controller, it must be replaced with the Tracer® Symbio 800 RTAC rotary chiller display upgrade kit (RCDB; sold separately).

The AFDW for RTAC can be ordered with a mounting frame to mount directly to the chiller or the drive can be mounted remotely from the chiller. Voltage options include only 460V/60 Hz/3 phase. All AFDW options include a mounting enclosure for the drive for outside installation. The AFDW units drive maximum rating options are as follows:

- 181, 228, or 287 amps for standard and low ambient, 460V units.
- 152, 180, or 257 amps for high or wide ambient, 460V units.

## Other Required Manuals

This manual must be used with the following publications:

- *Series R® Air-Cooled Helical Rotary Liquid Chillers, Model RTAC Installation, Operation, and Maintenance* (RTAC-SVX01\*-EN)
- *TR200 Programming Guide* (BAS-SVP04\*-EN)
- *TR200 New D-Frame, 110–400kW Operating Instructions* (BAS-SVX54\*-EN)
- *RCDB - Symbio 800 Controls Upgrade Kit RTAC Rotary Chiller Installation Instructions* (SO-SVN059\*EN)  
**Note:** *Instructions provided in SO-SVN059\*EN directly impact AFDW installation; review literature carefully!*
- *RTAC Component Location General Service Bulletin* (RTAC-SVB02\*-EN)



# Model Number Descriptions

## Digit 1, 2, 3 — Unit Function

AFD= Adaptive Frequency Drive

## Digit 4 — Development Sequence

W = Development Sequence  
(Air Cooled)

## Digit 5, 6, 7, — Unit Nominal Tons Capacity

140 = 140 Unit Nominal Tons  
155 = 155 Unit Nominal Tons  
170 = 170 Unit Nominal Tons  
185 = 185 Unit Nominal Tons  
200 = 200 Unit Nominal Tons  
225 = 225 Unit Nominal Tons  
250 = 250 Unit Nominal Tons  
275 = 275 Unit Nominal Tons  
300 = 300 Unit Nominal Tons  
350 = 350 Unit Nominal Tons  
400 = 400 Unit Nominal Tons  
450 = 450 Unit Nominal Tons  
500 = 500 Unit Nominal Tons

## Digit 8 — Chiller Voltage

4 = 460 Volts 60 Hz 3 Phase

## Digit 9 — Mounting Type

U = Unit Mount - Mounting  
Hardware Provided (both)  
R = Remote Floor Mount  
No Mounting Hardware

## Digit 10, 11 — Design Sequence

AA = Next Generation D-Frame

## Digit 12 — Unit Type<sup>1</sup>

N = Standard Efficiency/Performance  
H = High Efficiency/Performance  
A = Extra Efficiency/Performance

## Digit 13 — Condenser Ambient<sup>2</sup>

N = Standard Ambient  
L = Low Ambient  
H = High Ambient  
W = Wide Ambient

## Digit 14, 15, 16, 17 — Performance RLA Compressor 1A

\*\*\*\* = Factory Assigned

## Digit 18 — RLA (60Hz) Compressor 1A

*For Standard and Low Ambient:*

1 = 190 RLA - 60 Hz (derated 181)  
2 = 240 RLA - 60 Hz (derated 228)  
3 = 302 RLA - 60 Hz (derated 287)

*For High and Wide Ambient:*

4 = 190 RLA - 60 Hz (derated 152)  
5 = 242 RLA - 60 Hz (derated 180)  
6 = 302 RLA - 60 Hz (derated 257)

## Digit 19 — Circuit Breaker (Compr 1A)

*Circuit Breaker; 10K SCWR:*

A = 10K, 3P, 600V, 250A (LA) Frame  
B = 10K, 3P, 600V, 300A (LA) Frame  
C = 10K, 3P, 600V, 350A (LA) Frame  
D = 10K, 3P, 600V, 400A (LA) Frame

*Circuit Breaker; 35K SCWR:*

E = 35K, 3P, 600V, 250A  
F = 35K, 3P, 600V, 300A  
G = 35K, 3P, 600V, 350A  
H = 35K, 3P, 600V, 400A

*Circuit Breaker; 35K SCWR:*

J = 65K, 3P, 600V, 250A  
K = 65K, 3P, 600V, 300A  
L = 65K, 3P, 600V, 350A  
M = 65K, 3P, 600V, 400A

## Digit 20 — Not Used

X = Not used

## Digit 21, 22, 23, 24 — Performance RLA Compressor 2A

\*\*\*\* = Factory Assigned

## Digit 25 — RLA (60Hz) Compressor 2A

*For Standard and Low Ambient:*

1 = 190 RLA - 60 Hz (derated 181)  
2 = 240 RLA - 60 Hz (derated 228)  
3 = 302 RLA - 60 Hz (derated 287)

*For High and Wide Ambient:*

4 = 190 RLA - 60 Hz (derated 152)  
5 = 242 RLA - 60 Hz (derated 180)  
6 = 302 RLA - 60 Hz (derated 257)

## Digit 26 — Circuit Breaker (Compr 2A)

*Circuit Breaker; 10K SCWR:*

A = 10K, 3P, 600V, 250A (LA) Frame  
B = 10K, 3P, 600V, 300A (LA) Frame  
C = 10K, 3P, 600V, 350A (LA) Frame  
D = 10K, 3P, 600V, 400A (LA) Frame

*Circuit Breaker; 35K SCWR:*

E = 35K, 3P, 600V, 250A  
F = 35K, 3P, 600V, 300A  
G = 35K, 3P, 600V, 350A  
H = 35K, 3P, 600V, 400A

*Circuit Breaker; 35K SCWR:*

J = 65K, 3P, 600V, 250A  
K = 65K, 3P, 600V, 300A  
L = 65K, 3P, 600V, 350A  
M = 65K, 3P, 600V, 400A

## Digit 27 — Starter Type

Y = Wye-Delta Closed Transition  
Starter  
X = Across the Line

## Digit 28 — Chiller Control Type

A = AdaptiView™ Controls  
B = Symbio™ 800 Controls

## Digit 29 — AFD Type

1 = Outdoor Use

<sup>1</sup> Digit 12 in original unit model number.

<sup>2</sup> Digit 17 in original unit model number.



# Environmental Conditions

**Important:** *The location of the AFDW is important for proper performance and operating life.*

Unless designed for special environments, install the drive controller in an area where the following conditions exist:

- **Sufficient Airflow:** Minimum clearance for air circulation is 6 inch (15.25 cm) at each cabinet vent location.
- **Service Clearance:** Three feet (0.91 m) clearance is required in front of the enclosure for door swing and working space. Additional space may be required by local building codes, or for service equipment, such as hoists, that may be used for drive replacement. Follow all local codes and equipment requirements for the specific installation.
- **Elevation Derate:** For installations over 3300 ft (1000 m) above sea level, output power must be derated. For every 300 ft (91.4 m) over 3300 ft (1000 m) above sea level, derate the output current 1 percent.
- **Line Frequency:** 60 Hz.
- **Line Voltage:** 460V  $\pm$  10%.
- **Environmental Conditions:** Verify the installation location meets the conditions in the following table.

**Table 1. Environmental conditions**

Condition	Specification
Operating Temperature	32°F to 131°F (0°C to 55°C)
Storage Temperature (Ambient)	-40°F to 149°F (-40°C to 65°C)
Humidity	5% to 95% (non-condensing)



## Nameplates

A nameplate is included for each AFDW air-cooled drive unit. The nameplate includes the model number and serial number, which are required when contacting Trane for warranty, support or replacement parts.

The AFDW nameplate label (Trane Motor Controller Nameplate) is customized for each AFDW order and is specific to each unit. The Trane Motor Controller Nameplate must be installed on the Trane TR200 drive. Remove the adhesive backing and locate the label on the TR200 drive next to the AFD nameplate. The existing nameplate located on the RTAC chiller panel must also remain in place. When programming the current limit in the Tracer<sup>®</sup> TU, use the Trane Motor Controller Nameplate on the TR200 drive.

## Output Current

The output current listed on the Trane motor controller nameplate on the AFD is the maximum current required by the drive when the compressor motor is operated at a frequency that results in reduced motor voltage. The output current is used by the RTAC chiller controller for limiting chiller capacity at these conditions. The output current listed on the Trane motor controller nameplate on the AFD should NOT be confused with the chiller nameplate Rated Load Amps (RLA), which are unchanged by the retrofit. The RLA is to be considered the input current to the chiller.





# Dimensions

## Unit Submittal Drawings

Figure 1. Unit mount submittal drawing

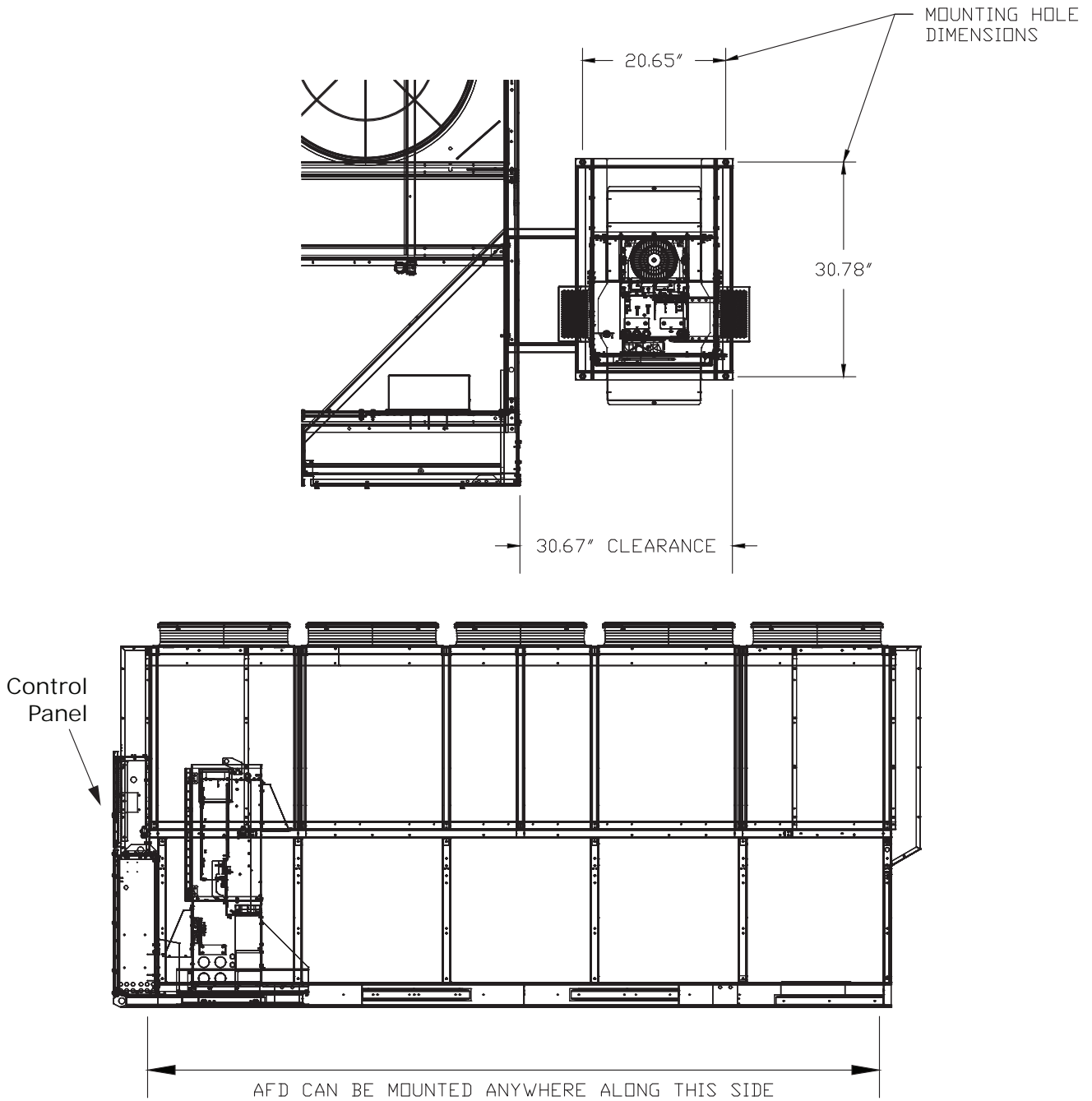



# Pre-Installation

## Required Tools

Standard service tools are required to perform the majority of the work. Following is a partial list of field supplied hardware/software components and special tools required to perform the display retrofit:

- RS-232 male DB9 to female DB9 pin to pin serial cable to connect the DynaView™ to a PC or laptop computer.

**Note:**

- The cable must NOT be a null-modem cable.
- The cable must be less than 50 feet in length.

- Type A to Type B USB cable to connect the Symbio™ 800 controller to a PC or laptop computer.
- A PC or laptop computer equipped with the following:
  - KestrelView™ service software, version 14.0 SP9 or 14.0 Service Pack 9 or newer.
  - Tracer TU service software, version 9.4.94 or newer.
- South pole magnet screwdriver (TOL01343).
- Electronics vacuum.
- Drill
- 3/16-inch Drill Bit

- 3/8-inch Drill Bit for Display Arm
- 25-inch Hole Saw (Close Mount Kit Only)
- Phillips Screwdriver
- Wrench for Fastening the Bolts for the Panel
- Wire Cutter for Large and Small Gage Wire
- Vacuum Pump
- Refrigerant Reclaim Unit
- Refrigerant Tanks
- Oil Pump
- Impact Drill for Concrete
- Rigging and Lifting Equipment
- Sheet Metal Punch
- 5/8-inch Drill Bit
- Torque Wrench
- 3/8-inch Anchor Bolts (for Pad Mount Option)
- 3/8-inch Washers
- 3/8-inch Nuts
- 1/4-inch Faston Connectors

## Parts

**Table 2. RTAC AFD upgrade kit – standard kit components**

Kit Part Number	Part Number	Mnemonic	Description	Qty
127500300001				
<b>Standard Kit Components</b>				
	572289580001 <sup>(a)</sup>		ASSEMBLY; REMOTE DRIVE ENCLOSURE	2
	X21130286140 or X21130286-14	GKT04054	Gasket for Enclosure door	60
	X13640734010	RNG02318	Choke Core	10
	X19210028300		Wire Tie	12
	507118170001		Cord Grip, 3/4 NPT, Split Grommet	2
	507119220001		Cord Grip Nut, 3/4 NPT	2
	507119210001		Cord grip, 1/2 NPT, Split Grommet	2
	507119230001		Cord Grip, Nut, 1/2 NPT	2
	X13260721020	RLY03704	Relay, 4PDT, 120VAC, 8amps	4
	X13260722010	HLD00579	Relay Socket, 4PDT, Din rail mount	4
	X13500224070	RAL01142	Din rail - For Relays	2
	X25030266010	SCR01621	Screw; M6 x 16mm Hex Cap, Thread Rolling - Din rail mounting hardware	4
	X13491363010	BLK01486	Din Rail End Stop	4
	X13650726090	SEN02133	Temperature sensors	2
	572289660001		Enclosure Duct	1
	572289670001		Enclosure Duct	1
	X25450030440		Block-off plate screws	5
	507118190001		Wire Taps	3
	SO-SVN043*-EN		Installation Instructions - AFDW Retrofit Air-Cooled Adaptive Frequency Drive™	1
	X39004015001		Label, Oil	4

**Table 2. RTAC AFD upgrade kit – standard kit components (continued)**

Kit Part Number	Part Number	Mnemonic	Description	Qty
	X39003759010		Label, Technical support	2
	X39001352010	18503790100	Nameplate	2

(a) See Table 5, p. 12 for enclosure components.

**Table 3. RTAC AFD upgrade kit – configurable components**

Category	Kit Part Number	Part Number	Mnemonic	Description	Qty
Schematics	N/A	507120560001		Schematic 2 compressor	1
		507120570001		Schematic 3 compressor	1
		507120580001		Schematic 4 compressor	1
Misc	N/A	57090466	BAR00266	Jumper Bars	6
Oil Related	127500350001	X09130085010	FLR03434	Oil Filter	1
		X23130334080	RNG01697	O-RING	1
		X23040455010	GKT03852	Oil Filter gasket	1
Drives	127500310001	X13612050001	DRV02684	DRIVE; TR200; D3H FRAME; 110KW; 380-480V	
	127500320001	X13612050002	DRV02685	DRIVE; TR200; D3H FRAME; 132KW; 380-480V	
	127500330001	X13612050003	DRV02686	DRIVE; TR200; D3H FRAME; 160KW; 380-480V	
Breakers 10K SCWR	127500360001	X13050864060	BKR02333	CIRCUIT BREAKER; 3P, 600V, 250A, (LA)FRAME	1
		507119130001		Breaker Back Plate	1
	127500370001	X13050864070	BKR02282	CIRCUIT BREAKER; 3P, 600V, 300A, (LA)FRAME	1
		507119130001		Breaker Back Plate	1
	127500380001	X13050864080	BKR02278	CIRCUIT BREAKER; 3P, 600V, 350A, (LA)FRAME	1
		507119130001		Breaker Back Plate	1
	127500390001	X13050864090	BKR02292	CIRCUIT BREAKER; 3P, 600V, 400A, (LA)FRAME	1
		507119130001		Breaker Back Plate	1
Breakers 35K SCWR	127500400001	X13050471030	BKR01784	CIRCUIT BREAKER; 3P 250A 600V, W/O LUGS	1
		507119130001		Breaker Back Plate	1
	127500410001	X13050471040	BKR01785	CIRCUIT BREAKER; 3P 300A 600V, W/O LUGS	1
		507119130001		Breaker Back Plate	1
	127500420001	X13050471050	BKR01786	CIRCUIT BREAKER; 3P 350A 600V, W/O LUGS	1
		507119130001		Breaker Back Plate	1
	127500430001	X13050471060	BKR01787	CIRCUIT BREAKER; 3P 400A 600V, W/O LUGS	1
		507119130001		Breaker Back Plate	1
Breakers 65K SCWR	127500440001	X13050471110	BKR01770	CIRCUIT BREAKER; 3P 250A 600V, W/O LUGS	1
		507119130001		Breaker Back Plate	1
	127500450001	X13050471120	BKR01771	CIRCUIT BREAKER; 3P 300A 600V, W/O LUGS	1
		507119130001		Breaker Back Plate	1
	127500460001	X13050471130	BKR01772	CIRCUIT BREAKER; 3P 350A 600V, W/O LUGS	1
		507119130001		Breaker Back Plate	1
	127500470001	X13050471140	BKR01773	CIRCUIT BREAKER; 3P 400A 600V, W/O LUGS	1
		507119130001		Breaker Back Plate	1



## Pre-Installation

**Table 4. RTAC AFD upgrade kit – optional unit mount add-on kit**

Kit Part Number	Part Number	Mnemonic	Description	Qty
127500340001				
<b>Unit Mount Kit Components</b>				
	572289790001 <sup>(a)</sup>		Frame; RTAC AFD Enclosure, Unit Mount	1
	507120520001		Screw; hex head 1/2 inch x 1-1/2 inch, Grade 8	4
	507120510001		Washer; plain, 1/2 inch Nominal, 1-1/8 OD, Grade 8	8
	507120530001		Lock Nut; 1/2", Grade 8	4
	X25020261010		Screw; .375-16 x 1.50, Hex Socket Cap	4
	X22050232120	WAS00612	Washer; Flat; 0.375 ID (nom) ID x.0875 OD x.083thk	4
	X28060206030	NUT01018	Lock Nut;.375 Nylon Insert.	4
	507120550001		Drill Template	1
	507120540001		Bracket; Mount - Stiffener	1
	X25020604050		Screw; M8 x 1.25mm x 25mm Hex HD- THD Rolling	4
	X25030215050	SCR00900	Screw; M8 x 1.25mm x 25mm Hex cap	3
	X22050202050	WAS00673	Washer; plain, 8mm (Nom.) ID x 25mm OD	6
	X28020724080		Lock Nut; M8 x 1.25mm with Polyamid Insert	3

(a) See Table 6, p. 13 for assembly components.

**Table 5. Components – AFD enclosure assembly (572289580001)**

Ref	Part Number	Description	QTY
1561	572289610001	Enclosure; Base, Left	1
1562	572289620001	Enclosure; Base, Right	1
1502	572275330001	Enclosure; Bottom Plate	1
1563	572289590001	Assembly; Enclosure	1
1505	572277670001	Assembly; Filter Duct Support	1
1506	572434860100	Bracket; Thermostat	1
1507	X13511540010	Control; Thermostat, Bi Metal Disc Limit	1
1509	572277230001	Enclosure; Front Plate	1
1511	572277200001	Enclosure; Top	1
1512	572277760001	Assembly; Front Cover	1
1514	X25020727020	Screw; Hex Head M5X10	2
1515	X21130286140	Gasket; Raw Material;.375T X 1W X 30 FT Roll	188
1516	572277520001	Assembly; Hood	2
1517	572277680001	Assembly; Door	1
1518	572272280001	Enclosure; Rod, Windstop	1
1520	X38010572010	Blower/Fan; AC Axial, 115 V, 50/60HZ, 6.75 DIA X 2.17W	1
1521	X09100804010	Guard; Metal Fan	1
1522	X25330033310	Screw; Phillips Pan Head, 10-24 X.50	6
1523	X19100065060	Plug; Conduit; 2.00 KO	2
1568	572289650001	Enclosure; Duct	1
1569	572289810001	Enclosure; Lifting Bracket	1
1570	572289800001	Enclosure; Lifting Bracket	1
9002	X25030266030	Screw; M6 X 12mm Hex Cap	68
9003	X28020028060	Nut; Hex; M10 X 1.50, Metric Hex	4
9004	X25030213430	Screw; Cap - Hex HD - Metric M4X10	7
9005	X28020775020	Nut; Hex M4-0.7 KEPSNUT	7
9013	X22010076050	Enclosure; Upper	1
9014	X28060505030	Nut; M6 Serrated Flange Locking	6
9015	X28020028040	Nut; Hex; M6 X 1.00, Metric Hex	5
9038	X25030214430	Screw; M6 X 20mm, Hex Cap	6
9039	X22040455050	M6 Spring Washer	6

**Table 6. Components – AFD enclosure, optional unit mount frame assembly (572289790001)**

Ref	Part Number	Description	QTY
0	572289790001	Assembly; AFD Mount	1
3	572289740001	Channel; C3 X 4P1 X 29.2"	1
2	572289750001	Channel; C3 X 4P1 X 22.7"	2
4	572289760001	Channel; C3 X 4P1 X 15"	1
5	572289770001	Channel; C3 X 4P1 X 10"	2
1	572289780001	Tube; 3" X 2" X 29.2	1

## AFD Sizing

Use the table below to determine which size drive should be installed on circuit 1 and circuit 2.

**Table 7. AFD sizing chart**

Unit Size (Tons)	Standard or Low Ambient <sup>(a)</sup>		High or Wide Ambient <sup>(b)</sup>	
	AFD Sizing		AFD Sizing	
	Compr 1A	Compr 2A	Compr 1A	Compr 2A
<b>Standard Efficiency<sup>(c)</sup></b>				
140	N110	N110	N110	N110
155	N110	N110	N132	N110
170	N110	N110	N132	N132
185	N132	N110	N160	N132
200	N132	N132	N160	N160
225	N132	N132	N160	N160
250	N132	N132	N160	N160
275	N110	N132	N132	N160
300	N132	N132	N160	N160
350	N132	N132	N160	N160
400	N132	N132	N160	N160
450	N132	N132	N160	N160
500	N132	N132	N160	N160
<b>High Efficiency<sup>(d)</sup></b>				
140	N110	N110	N110	N110
155	N110	N110	N132	N110
170	N110	N110	N132	N132
185	N132	N110	N160	N132
200	N132	N132	N160	N160
225	N132	N132	N160	N160
250	N132	N132	N160	N160
275	N110	N132	N132	N160
300	N132	N132	N160	N160
350	N110	N110	N132	N132
400	N132	N132	N160	N160
<b>Extra Efficiency<sup>(e)</sup></b>				
140	N110	N110	N110	N110
155	N110	N110	N132	N110
170	N110	N110	N132	N132
185	N132	N110	N160	N132
200	N132	N132	N160	N160
250	N110	N110	N110	N132

**Table 7. AFD sizing chart (continued)**

Unit Size (Tons)	Standard or Low Ambient <sup>(a)</sup>		High or Wide Ambient <sup>(b)</sup>	
	AFD Sizing		AFD Sizing	
	Compr 1A	Compr 2A	Compr 1A	Compr 2A
275	N110	N110	N132	N132
300	N110	N110	N110	N110
350	N110	N110	N132	N132

- (a) Model number digit 13 = N or L.
- (b) Model number digit 13 = H or W.
- (c) Model number digit 12 = N.
- (d) Model number digit 12 = H.
- (e) Model number digit 12 = A.

## Global Connector Harnesses

**Figure 2. CAB01151/CAB01153 global connector harness**

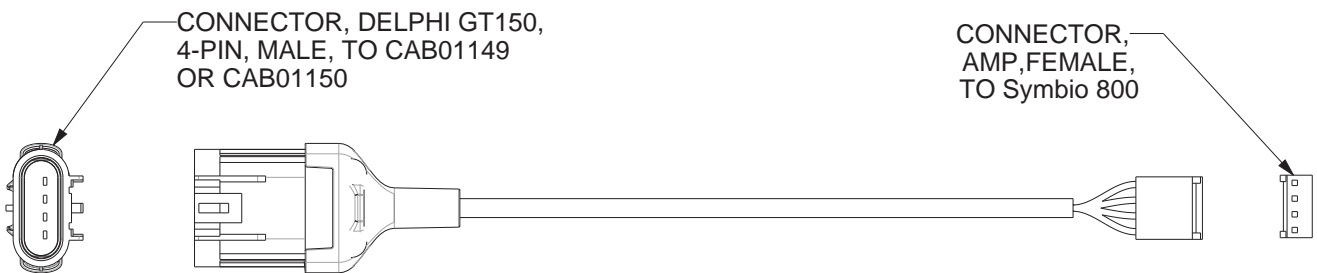

**Figure 3. CAB01155/CAB01534 global connector harness**

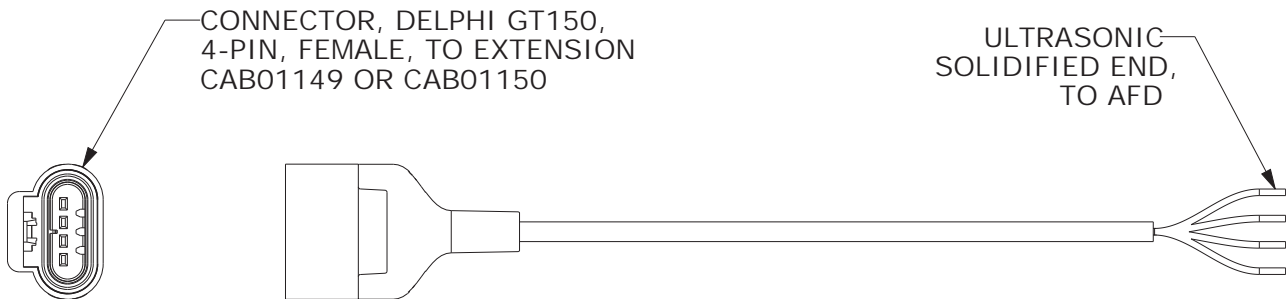

**Figure 4. CAB01149/CAB01150 global connector harness**

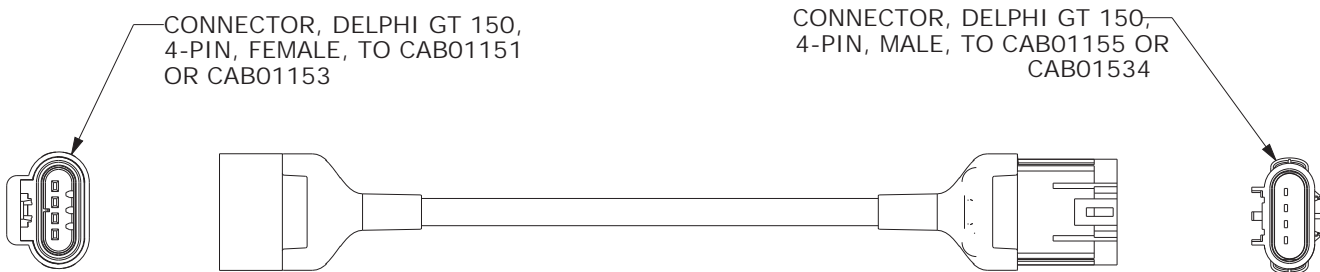

## Required Parts – Not Supplied

- Modbus® Cable (for Remote or Wall Mount)

Because the distance varies with each application, Modbus connectors are not provided for remote and wall mount kits. The Modbus connection requires a unique connection type for the Symbio™ 800 and for the AFD (listed above). The Global Connector Extension is used for spanning the remaining distance between the panel and the AFD. Maximum length is 250 feet.

### **NOTICE**

#### **Excessive Cable Lengths Between AFDW Drive and Compressor Motor!**

**Trane assumes no responsibility for equipment damage caused by use of improper cable lengths. The variable frequency drive industry recommends that the length of the electrical cables connecting a drive unit to a motor should be kept to less than 250 feet to protect the motor from reflected voltage waves that can cause the motor to fail. Cable lengths that exceed 250 feet between the drive and the motor create the potential for damage to occur to the motor windings and/or insulation.**

- Global Connector Harness without Conduit:
  - CAB01151 (39 inches) or CAB01153 (78 inches) for Symbio 800 connection (See [Figure 2, p. 14.](#)).
  - CAB01155 (39 inches) or CAB01534 (78 inches) for AFD connection (See [Figure 3, p. 14.](#)).
  - CAB01149 (39 inches) and/or CAB01150 (78 inches) Global Connector Extension for variable distance between the control panel and AFD (See [Figure 4, p. 14.](#)).

- Global Connector Harness with Conduit.

**Note:** *If conduit is required for Modbus® wire, a shielded 16 gage wire pair can be used in lieu of global connectors. Use end connections from CAB01151 and CAB01149. See “Control Wiring,” p. 33.*

- OIL00315/317
- Cold Filter (FLR01682)
- 3/8-inch Anchor Bolts
- Refrigerant
- Control Wire and Conduit for Control Power Wiring
- 2-1/2 Hole Saw or Punch

## Preparation in DynaView™

### Check the Configuration and Setpoints in the DynaView Display

1. Check the current configuration of the DynaView™ and confirm all settings are correct. Make any necessary changes.
2. Check the current chiller setpoints programmed into the DynaView and confirm that they are correct for the unit. Make any necessary changes.

### DynaView Configuration and Setpoints

Configuration and setpoint values are exported from the DynaView control in order to successfully configure the upgraded Symbio™ 800 controller. Using KestrelView™ on a PC or laptop computer:

1. Generate a Chiller Service Report from the DynaView with Level 4 active. In the **Reports** menu, select **Chiller Service Report**.
2. Select all reports and convert the report to PDF. The PDF will be required to manually copy configuration and setpoint values with Tracer® TU after the Tracer AdaptiView™ display and Symbio 800 are installed.
3. Verify the PDF was printed. The PDF will be used when configuring the upgraded Symbio 800 controller within Tracer TU.

After the configurations and settings from the CH530 DynaView controller have been saved to a file on your service computer, the controller change-out can proceed.

Figure 5. Select reports



Figure 6. Accessing chiller service report

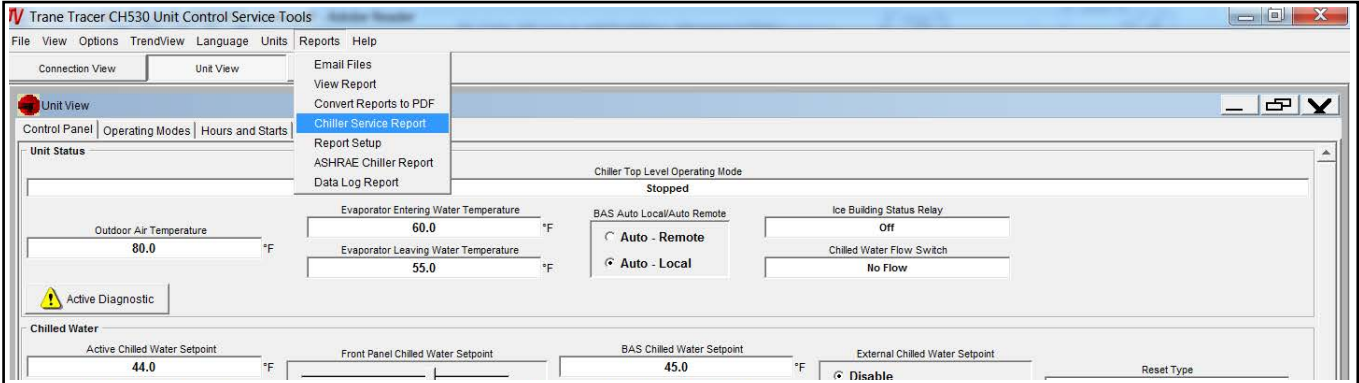

Figure 7. Chiller service report (example)

Wednesday, October 11, 2017 2:43:28 PM CDT

**Chiller Service Report**

Prepared for:

Technician:

Chiller Name:

Model Number: RTAC450JUR0NUAGNL1TX1TDB800TN10NREX

Confirm Code: 01CG

Serial Number: U13XD1234567890

Job Name:

Work Order Number:

Location:

Sales Office Name:

Sales Order Number:

Sales Office Address:

Sales Office Phone Number:

Customer Name:

Customer Address:

Customer Phone Number:

**Notes:**

Chiller Status			
Chiller			
Operating Mode	Diagnostic Shutdown: Stop	Ice Building Status Relay	Off
Front Panel Auto/Stop	Stopped	BAS Chilled Water Setpoint	45.0 °F
Outdoor Air Temperature	80.0 °F	BAS Current Limit Setpoint	99.0 % RLA
External Auto/Stop	Auto	Chiller Top Level Operating Mode	Stopped
External Emergency Stop	Auto	Chiller Sub Operating Mode	Diagnostic Shutdown - Manual Reset
Active Chilled Water Setpoint	44.0 °F	Chiller Sub Operating Mode	Local Stop
Active Current Limit Setpoint	120.0 % RLA	Chiller Sub Operating Mode	
Active Ice Termination Setpoint	31.0 °F	Chiller Sub Operating Mode	
External Current Limit Setpoint	75.0 % RLA	Chiller Sub Operating Mode	
External Chilled Water Setpoint	23.8 °F	Chiller Sub Operating Mode	
Evaporator Entering Water Temperature	60.0 °F	BAS Communication	Established
Evaporator Leaving Water Temperature	55.0 °F	Chilled Water Pump Relay	Off



## Oil and Refrigerant Removal

### **⚠ WARNING**

#### **Refrigerant under High Pressure!**

Failure to follow instructions below could result in an explosion which could result in death or serious injury or equipment damage.

**System contains refrigerant under high pressure. Recover refrigerant to relieve pressure before opening the system. See unit nameplate for refrigerant type. Do not use non-approved refrigerants, refrigerant substitutes, or refrigerant additives.**

*Note:* See “[Component Location](#),” p. 18 for components referenced in steps below.

### Procedure for Circuits with Two Compressors

1. Connect hoses from recovery unit to chiller, configured to recover liquid refrigerant (Push-Pull/Mechanical Pump). Use 1/4-inch access valve on the evaporator filter (number 24).
2. Open valves on chiller and start recovery machine. Complete the transfer of the liquid from the unit to the cylinder(s).
3. Once all of the liquid has been recovered, reconfigure the recovery unit for vapor by moving the hose from liquid port to a vapor port to separate the refrigerant from the Solest 68 (Oil0048).
4. Recover vapor down to 0 psi.
5. Weigh and record the total amount of refrigerant removed from the chiller.
6. Pressurize the evaporator and condenser to 2 psi nitrogen at the evaporator filter (number 24).
7. Remove oil return line at each compressor. Open oil return solenoid valve (number 11 and 30). Collect and weigh all oil removed from the unit.
8. Remove oil filter and replace with a new filter and gasket for each compressor.  
*Note:* Oil filter and gasket changes are required on 3-compressor and 4-compressor units.
9. Remove plug at the bottom center of each oil separator, drain and measure oil.
10. If the RTAC unit has an oil cooler, remove oil line at the oil line service valve (number 13 and 35). Pressurize the unit with 2 psi of nitrogen at the oil service valve (number 18) and measure oil removed.
11. Reconnect the oil return line and the oil line and install the oil separator plug.
12. Add the oil charge per circuit of Solest 120 (OIL00315/OIL00317) according to unit nameplate. On dual compressor circuits, add ½ of the total circuit amount at

each compressor oil filter (13 and 35). Otherwise, add the entire charge for single compressor circuits.

13. Repeat steps 6 through 12 for circuit 2.
14. Perform pressure test.
15. Evacuate the unit to a minimum of 500 microns and perform pressure rise test.
16. Add refrigerant according to unit nameplate charge.
17. Apply provided oil label sticker listing the new oil, OIL00315 at the oil separator and at each compressor on the oil filter casing (13 and 35) for each circuit.

## Component Location

See [Figure 8, p. 18](#), for RTAC circuits with a single compressor.

See [Figure 9, p. 19](#), for circuits with dual compressors.

See [Table 8, p. 20](#), for component number descriptions.

**Figure 8. Component locations – RTAC single compressor circuits**

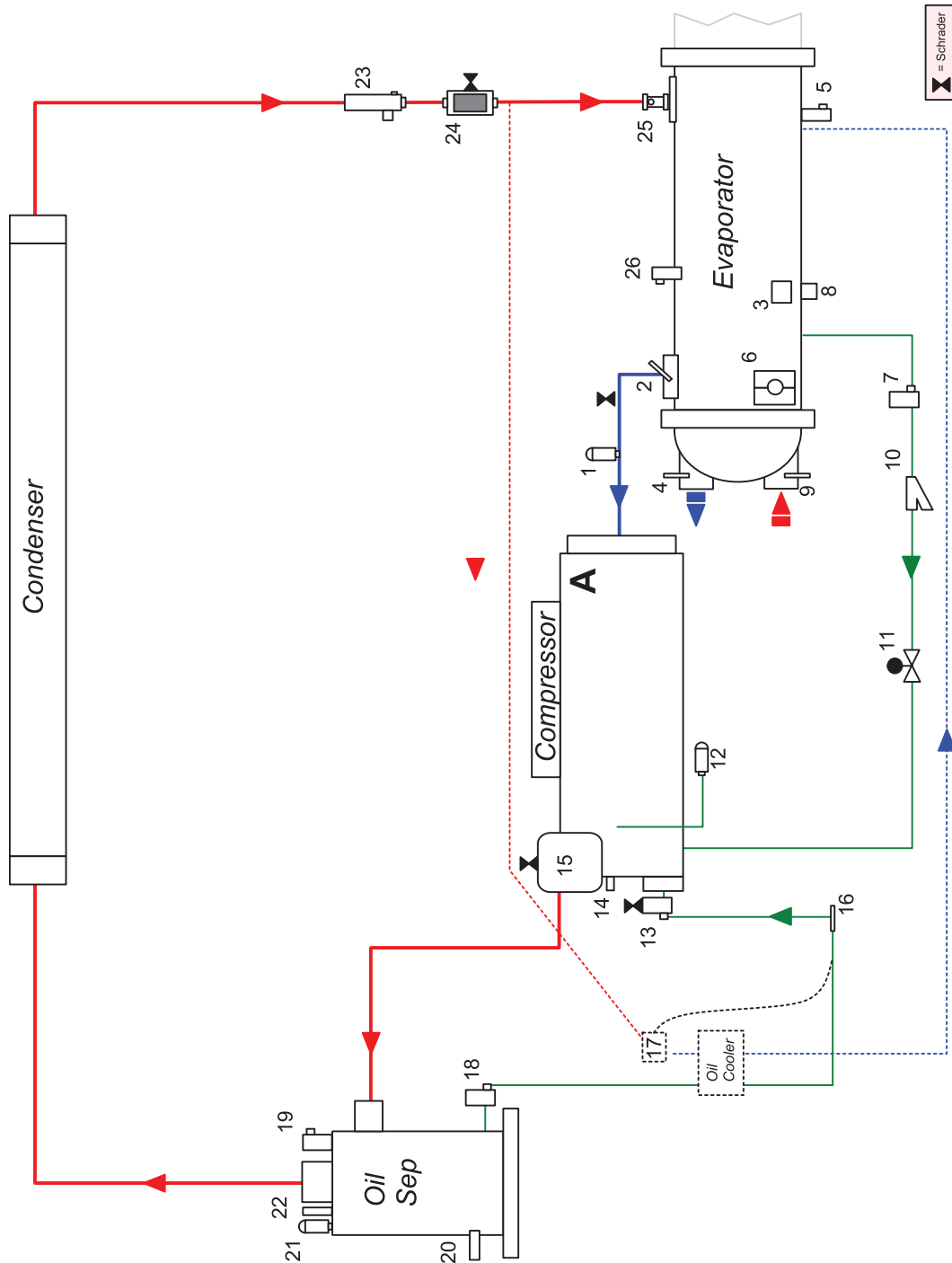
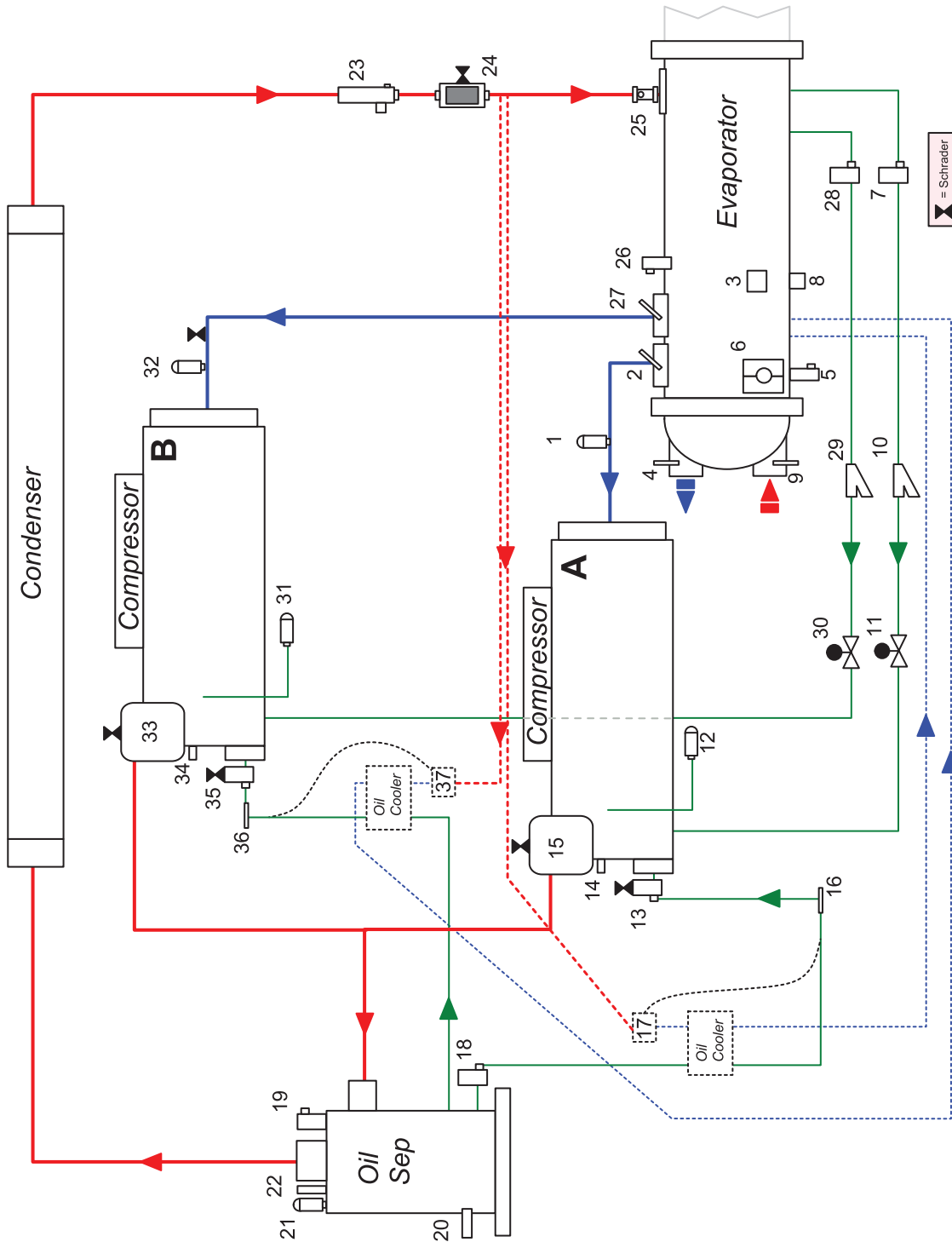

Figure 9. Component locations – RTAC dual compressor circuits





## Pre-Installation

**Table 8. Components**

Ref Number	Description	Notes
<b>All Circuits (single and dual compressor) – See Figure 8, p. 18 and Figure 9, p. 19.</b>		
1	Suction Pressure Transducer	
2	Suction Service Valve	
3	Relief Valve - 200 psi	
4	Leaving Water Temperature Sensor	
5	Service Valve 3/8"	
6	Liquid Level Sensor	
7	Oil Return Shutoff Valve	
8	Freeze Protection Plug	
9	Entering Water Temperature Sensor	
10	Oil Return Strainer	
11	Oil Return Solenoid	Only on units with a design sequence of C0 and earlier.
12	Intermediate Pressure Transducer	
13	Oil Line Service Valve	
14	HPC - 315 psi	
15	Discharge Isolation Valve	
16	Oil Temperature Sensor	
17	TRV	Only on units with optional Oil Cooler.
18	Oil Drain Valve	
19	Access valve - 3/4"	
20	Oil Separator Heater	Design Sequence A0, B0: Direct Immersion. Design Sequence C0 and later: In Thermowells.
21	Discharge Pressure Transducer	
22	Relief Valve - 350 psi	
23	Liquid Line Service Valve	
24	Refrigerant Filter	
25	EXV	
26	Service Valve - 3/8"	
<b>Dual Compressor Circuits Only – See Figure 9, p. 19</b>		
27	Suction Service Valve	
28	Oil Return Shutoff Valve	
29	Oil Return Filter	
30	Oil Return Solenoid	Only on units with a design sequence of C0 and earlier.
31	Intermediate Pressure Transducer	
32	Suction Pressure Transducer	
33	Discharge Isolation Valve	
34	High Pressure Cutout (315 psi)	
35	Oil line Service Valve	
36	Oil Temperature Sensor	
37	TRV	Only on units with optional Oil Cooler.



# Installation

**Note:** It is recommended, but not required, that retrofits outlined in service bulletin RTAC-SVC023\*-EN (for units with design sequence A0 through V0) or RTAC-SVC026\*-EN (for units with design sequence W0 through Z0) be performed prior to installation of drive.

## ⚠ WARNING

### Hazardous Voltage w/Capacitors!

Failure to disconnect power and discharge capacitors before servicing could result in death or serious injury. Disconnect all electric power, including remote disconnects and discharge all motor start/run capacitors before servicing. Follow proper lockout/tagout procedures to ensure the power cannot be inadvertently energized. For variable frequency drives or other energy storing components provided by Trane or others, refer to the appropriate manufacturer's literature for allowable waiting periods for discharge of capacitors. Verify with a CAT III or IV voltmeter rated per NFPA 70E that all capacitors have discharged.

## Shutdown Power

1. Using lockout/tagout safety procedures, remove chiller main power.
2. Open all starter and control panel disconnect switches and secure them in the open position.
3. Confirm the power is off to the control panel of the chiller.

## RTAC Symbio 800 Controls Upgrade

If unit includes a CH530 controller, the Tracer AdaptiView RTAC rotary chiller display upgrade kit (RCDB) must be installed. Follow the installation instructions in RCDB - Symbio 800 Controls Upgrade Kit RTAC Rotary Chiller Installation Instructions (SO-SVN059\*-EN) before installing the AFDW drive.

If the chiller already has a Symbio 800 controller, it can be reused.

**Important:** Whether new or existing, the Symbio™ 800 must have a software upgrade to support the AFDW. For more information, see “Symbio 800 Software Installation and Configuration,” p. 38.

## Important Note on Panel Configuration Variations

**Important:** RTAC units have many different panel configurations, which could not all be addressed specifically in this document. Follow steps as appropriate for the particular unit configuration. For example, some RTAC electrical panel designs include bus bars, which can either be removed and reused, or a lug attached.

## AFDW Kit Options

The AFDW kit has the following options:

- Unit mounting kit for mounting the AFD enclosure directly to the RTAC chiller base.
- Circuit breakers for wire protection from the panel to the AFD and compressor.

## Panel Component Installation

### Installing Enclosure and Drive

1. Determine where the drive enclosure will be mounted.
2. Prepare mounting location pad or optional unit mount bracket.

### Remote Mount Option

If the enclosure will be mounted to a remote pad, the bottom bracket of the drive can be bolted to 3/8-inch anchor bolt studs. The 3/8-inch anchor bolt locations can be determined from the enclosure dimensions located in [Figure 10, p. 22](#).

Figure 10. Enclosure dimension drawing

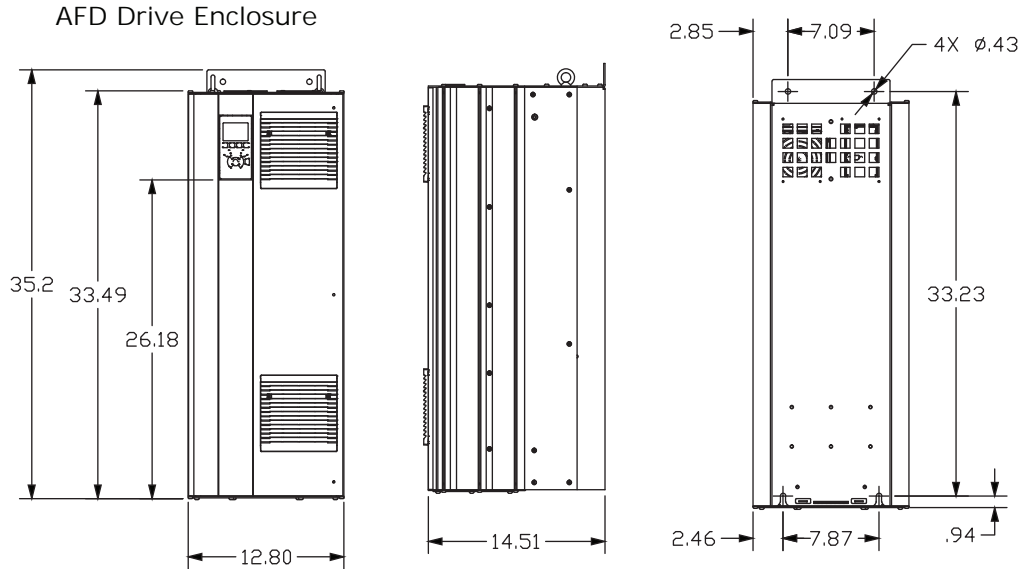

**Unit Mount Option**

See Figure 1, p. 9 for unit mount dimensions.

If the enclosure will be mounted to the unit, follow the instructions below to mount the unit mounting bracket to the RTAC chiller.

1. Determine mounting location. Verify the designated location:
  - a. Allows for proper conduit clearance.
  - b. Does not result in upper support bracket interference with cross members as shown below.

Figure 11. Unit mount option



2. After determining the location for the enclosure, use the template provided in the kit to mark the drilling locations for the mounting holes on the RTAC chiller base. See figure below.

Figure 12. Mark drilling locations with template



3. Use a smaller bit to drill pilot holes in the base at the four marked locations. See Figure 13, p. 23.
4. After drilling the pilot holes, use a 5/8-inch bit to drill the four marked locations. See following figures.

**Figure 13. Drill pilot holes in base**



**Figure 14. Drill 5/8-inch holes in base**



**⚠ WARNING**

**Heavy Objects!**

Failure to properly lift waterbox could result in death or serious injury. Each of the individual cables (chains or slings) used to lift the waterbox must be capable of supporting the entire weight of the waterbox. The cables (chains or slings) must be rated for overhead lifting applications with an acceptable working load limit. Refer to the waterbox weights table.

**Table 9. Weights (lb)**

AFD Drive Weight	Enclosure Weigh	Combined AFD Drive and Enclosure Weight	Unit Mounting Bracket
135	190	325	49

- Using a suitable lifting device, hoist the mounting bracket into place and secure to the unit using four grade 1/2-inch bolts and washers. See figure below.
- Torque the bolts to 85 ft-lb.

**Figure 15. Mounting bracket installation**



**Unit Mount Enclosure Installation**

- Using a suitable spreader-bar and proper lifting methods lift enclosure and place on top of the mount.
- Align the enclosure mounting holes and fasten with 5/16-inch grade 5 bolts.
- Torque enclosure bolts to 125 in-lb.

**Figure 16. Attach enclosure to mount**



**Pad Mount Enclosure Installation**

- Using a suitable spreader-bar and proper lifting methods, lift enclosure and place on top of the mounting pad.
- Align the enclosure mounting holes with the 3/8-inch anchor bolt studs and fasten with field provided 3/8-inch washers and nuts.
- Torque nuts to 23 in-lb.

**Mounting the AFD Inside the Enclosure**

1. Remove the bottom front access panel of the enclosure as shown in figures below.

**Figure 17. Remove access panel**

**Figure 18. Remove access panel**

2. Remove the bottom airflow duct at the back of the enclosure as shown in figure below.

**Figure 19. Remove bottom airflow duct**

3. Remove the top cover of the enclosure as shown in figures below.

**Figure 20. Remove top cover of the enclosure**

**Figure 21. Remove top cover of enclosure**

**Rigging and Lifting Procedures for AFDW Drive Units**
**⚠ WARNING**
**Heavy Objects!**

Failure to follow instructions below or properly lift unit could result in unit dropping and possibly crushing operator/technician which could result in death or serious injury, and equipment or property-only damage. Ensure that all the lifting equipment used is properly rated for the weight of the unit being lifted. Each of the cables (chains or slings), hooks, and shackles used to lift the unit must be capable of supporting the entire weight of the unit. Lifting cables (chains or slings) may not be of the same length. Adjust as necessary for even unit lift.



**⚠ WARNING**

**Improper Unit Lift!**

Failure to properly lift unit in a LEVEL position could result in unit dropping and possibly crushing operator/ technician which could result in death or serious injury, and equipment or property-only damage. Test lift unit approximately 24 inches (61 cm) to verify proper center of gravity lift point. To avoid dropping of unit, reposition lifting point if unit is not level.

*Important:* Anti-roll strap is recommended for drive unit stabilization during lifting.

**Unit Lifting Points – Preferred Lifting Method**

The preferred method for lifting an AFDW drive unit to position it for installation is to use an identical individual hoisting device at each lift point.

**Figure 22. Preferred lifting method using two identical individual hoists**



**Unit Lifting Points – Alternative Lifting Method**

For single hoisting device lift, a spreader bar must be used to allow adjustment of rigging for a balanced lift around its center of gravity and full control.

**Figure 23. Alternative lifting method using a single hoist and spreader bar**



**Drive Installation**

See [“Rigging and Lifting Procedures for AFDW Drive Units,” p. 24](#) and [Table 9, p. 23](#) for unit weights before lifting the drive and enclosure onto mounting bracket or mounting pad.

Lift drive into the enclosure, and mount on the four 10mm studs. Install washer and tighten mounting nuts.

**Figure 24. Lift drive**



**Figure 25. Install on mounting studs**



## Installation

**Note:** The brackets on the enclosure can be used to lift the enclosure with the drive mounted inside. See figure below.

**Figure 26. Lifting brackets**



**Important:** The top cover must be attached to the enclosure before lifting. Never lift the enclosure without the top cover of the enclosure attached.

1. Reassemble bottom airflow duct.
2. Reassemble the front bottom access panel.

## Block Off Plate Installation

1. Remove screw at the top of the AFD as shown below.

**Figure 27. Remove screw**

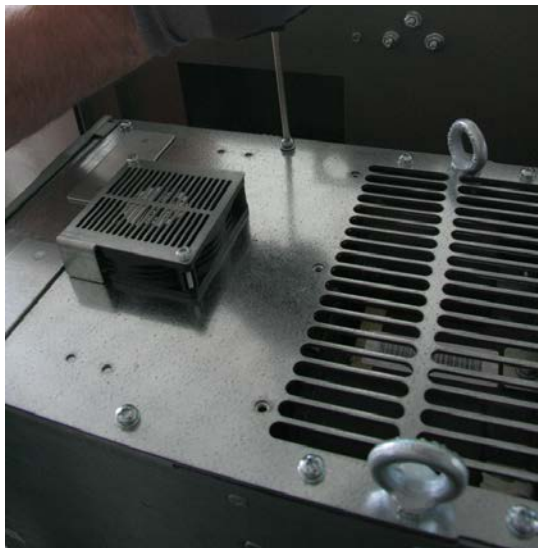

2. Install block off plates at the top of the drive using the existing screw (removed previously) and the provided hardware. See figures below.

**Figure 28. Install block off plate on top of drive**



**Figure 29. Install block off plate**

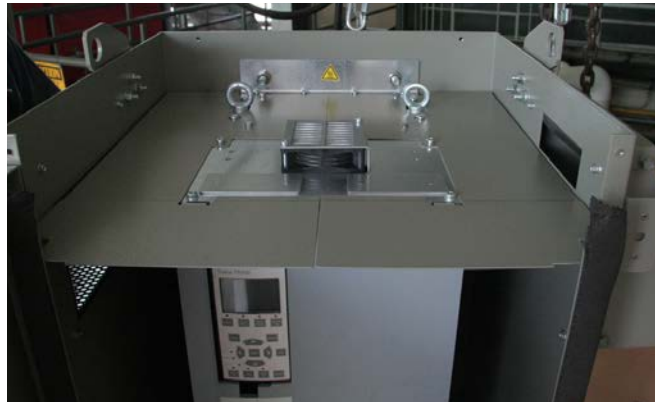

3. Apply caulking sealant to the seams in the top cover and reinstall the top cover of the enclosure.

**Figure 30. Apply caulk**



## Weather Proofing Enclosure

1. Apply sealing gasket to the front door of the AFD enclosure.

**Figure 31. Gasket installed**



2. Apply supplied caulking sealant to all seams and gaps of the inside of the AFD enclosure as shown in figures below.

**Figure 32. Apply sealant**



**Figure 33. Apply sealant**



# Installation – Electrical

## ⚠ WARNING

### Hazardous Voltage w/Capacitors!

Failure to disconnect power and discharge capacitors before servicing could result in death or serious injury. Disconnect all electric power, including remote disconnects and discharge all motor start/run capacitors before servicing. Follow proper lockout/tagout procedures to ensure the power cannot be inadvertently energized. For variable frequency drives or other energy storing components provided by Trane or others, refer to the appropriate manufacturer's literature for allowable waiting periods for discharge of capacitors. Verify with a CAT III or IV voltmeter rated per NFPA 70E that all capacitors have discharged.

## Electrical Connections

### RTAC Panel Wiring (Circuit 1 or 2)

**Note:** Use existing schematics, new schematics, and pin out tables for all wiring connections.

1. Remove existing compressor wire at contactor 1K1 (or 2K1 for circuit #2) as shown below.

**Figure 34. Remove compressor wire**



2. Disconnect wye delta resistors and remove resistors if panel space is needed to mount the optional circuit breaker.

3. The 1K1 (or 2K1 for circuit #2) contactor can be removed (Figure 35, p. 28) or left in place (Figure 36, p. 28).

**Figure 35. Contactor removed**



**Figure 36. Contactor left in place**

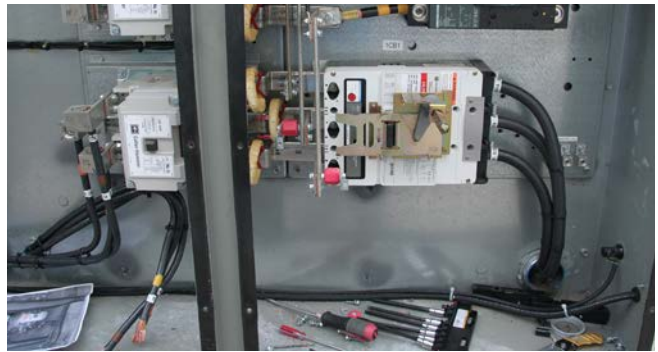

1. Install circuit breaker in the panel (Optional) in a suitable location in the panel to allow proper clearance and bend radius for power wire. See figures below. The need for overcurrent wire protection will depend on local codes, mounting location, and wire size selected.

**Note:** A back-plate is provided and should be used if an existing back-plate is not available.

**Figure 37. Install circuit breaker**



Figure 38. Circuit breaker installed

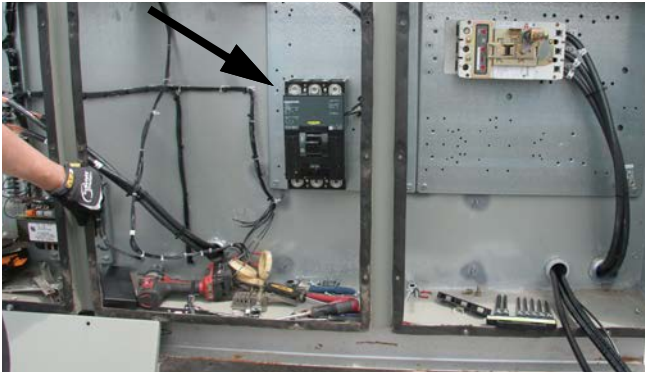

Figure 40. Conduit holes



4. Route wire and conduit to the AFD enclosure as shown below.

Figure 41. Route power wire to AFD



Figure 42. Route power wire to AFD



**⚠ WARNING**

**Conform to All Applicable National, State, and Local Electrical Codes!**

Failure to follow all applicable codes could result in an arc flash event, electrocution, explosion, or fire, which could result in death or serious injury. Users **MUST** conform to all applicable national, state, and local electrical codes during the electrical installation and servicing of this product.

**Note:** All field wire sizing must be done by a licensed electrician.

- a. For units **with Buss bar connections** inside the RTAC panel:  
Connect from buss bar at the termination points from the removed 1K1 breaker with wire lugs and connect to the provided breaker according to the wiring schematics. See [Figure 36, p. 28](#).
  - b. For units **without Buss bar connections**:  
Connect from termination point that is upstream of the removed 1K1 breaker with wire lugs and connect to the provided breaker according to the wiring schematics.
2. Install field provided compressor wire to load side of the RTAC panel (optional circuit breaker). See figure below.

Figure 39. Load side compressor wire



3. Use a sheet metal punch to create conduit connection points at the RTAC panel.

## AFD Enclosure Wiring

Figure 43. AFD drive terminal locations

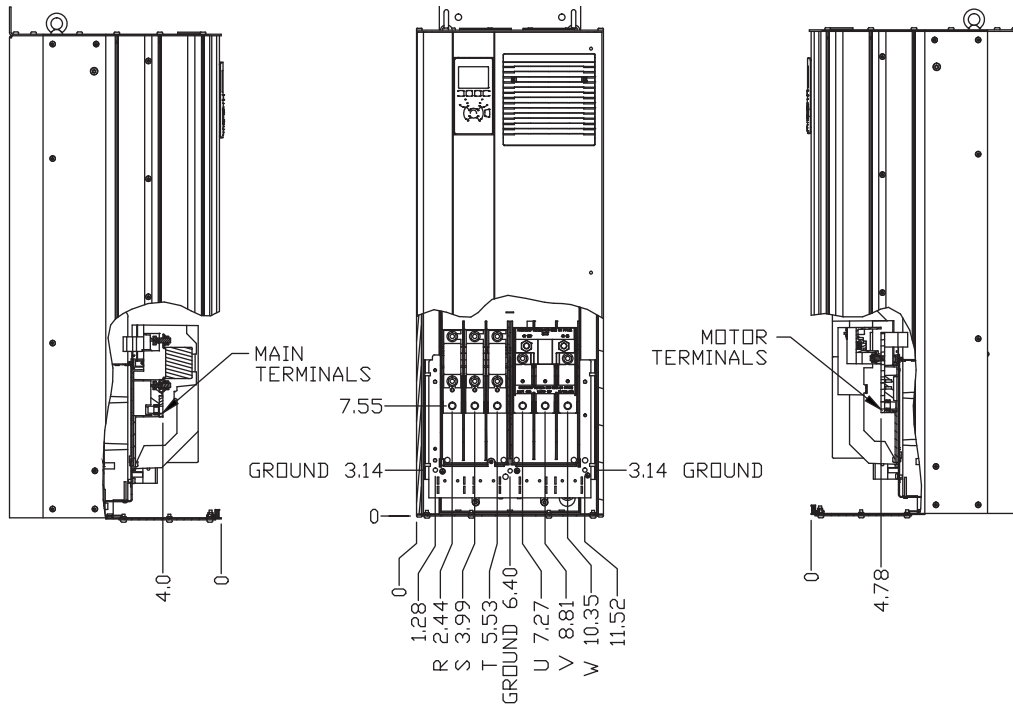

2. Install conduit and wire to the AFD enclosure.

Figure 45. Install conduit at AFD enclosure



### **⚠ WARNING**

#### **Hazardous Voltage w/Capacitors!**

Failure to disconnect power and discharge capacitors before servicing could result in death or serious injury. Disconnect all electric power, including remote disconnects and discharge all motor start/run capacitors before servicing. Follow proper lockout/tagout procedures to ensure the power cannot be inadvertently energized. For variable frequency drives or other energy storing components provided by Trane or others, refer to the appropriate manufacturer's literature for allowable waiting periods for discharge of capacitors. Verify with a CAT III or IV voltmeter rated per NFPA 70E that all capacitors have discharged.

1. Use a sheet metal punch to create conduit connection points at the AFD enclosure as shown below.

Figure 44. Create AFD conduit connection



3. Install load side wire to the input of the AFD.

**Figure 46. Load side AFD wiring**



4. Mount the blue cores to the mounting bracket at the bottom right of the enclosure.

**Note:** Confirm wires are routed through the center of the cores. Use the wire ties to prevent the wires from touching the core.

**Figure 47. Wires through blue cores**

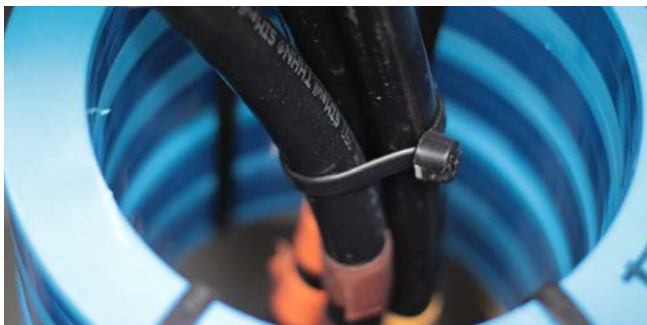

5. Install output wire at AFD and route wire and conduit to compressor 1A for circuit #1 (Compressor 2A for circuit #2).

**Figure 48. Install output wire at AFD**



6. Cut the bottom portion of the touch safe covers to the correct size for both input and output power wire for the AFD. See figures below.

**Figure 49. Cut touch safe covers**



**Figure 50. Touch safe cover sizing**



7. Install touch safe covers to the AFD.

**Figure 51. Touch safe cover installation**



**Figure 52. Touch safe cover installed**



## Compressor Wiring

### ⚠ WARNING

#### Hazardous Voltage w/Capacitors!

Failure to disconnect power and discharge capacitors before servicing could result in death or serious injury. Disconnect all electric power, including remote disconnects and discharge all motor start/run capacitors before servicing. Follow proper lockout/tagout procedures to ensure the power cannot be inadvertently energized. For variable frequency drives or other energy storing components provided by Trane or others, refer to the appropriate manufacturer's literature for allowable waiting periods for discharge of capacitors. Verify with a CAT III or IV voltmeter rated per NFPA 70E that all capacitors have discharged.

### NOTICE

#### Compressor Damage!

Before connecting power wire to the motor terminals, with the motor terminal jumpers removed, verify proper phasing between the drive and motor terminals with an Ohmmeter for all connections. Improper phasing occurs between the drive and motor terminals can cause compressor damage.

1. Remove existing compressor power wires at compressor 1A motor terminals for circuit #1 (compressor 2A motor terminals for circuit #2).

**Note:** Backup wrench is required on lower nuts when removing motor leads.

Figure 53. Remove compressor wiring



2. Use a sheet metal punch to create conduit connection points at the compressor junction box as shown below.

Figure 54. Create compressor conduit connection point



3. Install conduit and wire to the compressor motor terminal box.

Figure 55. Route wires to compressor



Figure 56. Install conduit at compressor



4. Install new compressor wire(s) to the compressor 1A, circuit #1 junction box (compressor 2A motor terminals for circuit #2). Attach wires to appropriate motor terminals as shown.

**Note:** Use a backup wrench for bottom nut to prevent damage to the motor terminals.



**Figure 57. Connect wires to motor terminals**



5. Install shorting bars for units with wye delta type starters as shown below. Existing across-the-line starters should already have shorting bars.

**Figure 58. Install shorting bars for wye-delta starters**



## Control Wiring

### ⚠ WARNING

#### Hazardous Voltage w/Capacitors!

Failure to disconnect power and discharge capacitors before servicing could result in death or serious injury. Disconnect all electric power, including remote disconnects and discharge all motor start/run capacitors before servicing. Follow proper lockout/tagout procedures to ensure the power cannot be inadvertently energized. For variable frequency drives or other energy storing components provided by Trane or others, refer to the appropriate manufacturer's literature for allowable waiting periods for discharge of capacitors. Verify with a CAT III or IV voltmeter rated per NFPA 70E that all capacitors have discharged.

1. Find a suitable location for control relays provided. Install the DIN rail and 1K20 and 1K30 relays as shown in [Figure 59, p. 33](#). These relays will replace the 1K1 and 1K2 auxiliary contacts.

**Figure 59. Control relay installation**

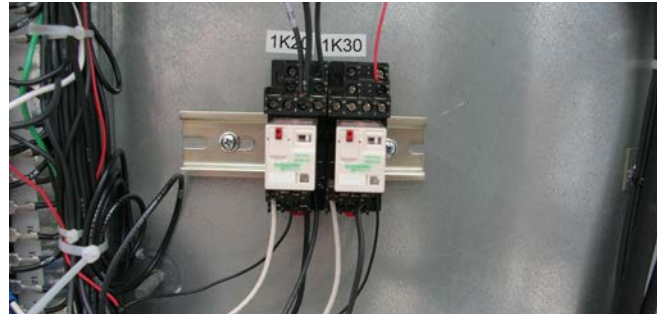

2. Route control wire conduit between RTAC Panel and AFD enclosure.

**Figure 60. Route control wire conduit**



3. Route global connector wire for both AFDs ([Figure 61, p. 33](#)) through the RTAC panel using the cord grip fittings provided. See [Figure 62, p. 33](#).

**Figure 61. Route global connector wires**



**Figure 62. Global connector wires**

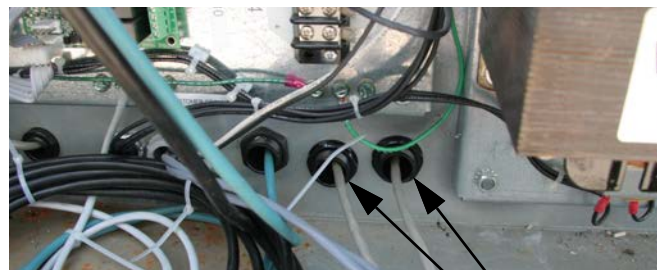

## Installation – Electrical

4. Connect global connector buss from the AFD to the Symbio™ 800 module.

**Figure 63. Connect global connector buss to Symbio 800**



5. Follow existing and new control wiring schematics and pinout tables in “Control Device Wiring Tables,” p. 35 for control wire connections for the control devices listed below.
  - a. Oil Solenoid
  - b. Heaters
  - c. Main Unit Panel Fan (High Ambient Models Only)
  - d. Under/Over Voltage Detection
  - e. 1U1 AFD: For the following control wire connections, use 18AWG shielded wire and suitable conduit.
    - i. Connect 16 AWG from terminal on TB5 1-8 (115V) to relay 1K20.
    - ii. Connect 16 AWG wire from relay 1K20 and route in conduit to thermostatic switch (3TS1) inside AFD enclosure; connect with ¼-inch Faston connector. See [Figure 61, p. 33](#).
    - iii. Connect 16 AWG wire from second terminal on thermostatic switch (3TS1) to fan (3B20); connect with 3/16-inch Faston connector.
    - iv. Route 16 AWG wire in conduit from second terminal on fan (3B20) back to main unit panel and connect to terminal block TB5 9-16 (115 V).
  - f. Compressor Discharge Temperature Sensor.

### NOTICE

#### Equipment Damage!

**Excessive heat will damage the sensor electronics. Do not mount the electronics portion of the discharge temperature sensor to the discharge line.**

- i. Install Compressor discharge temperature sensor to compressor 1A for circuit #1 and compressor 2A for circuit #2.
- ii. Use thermal paste and attach the sensing element with a tie wrap as shown in the following figure.

**Figure 64. Use thermal paste on sensor**



- iii. Use insulating tape to cover the sensing element as shown in figures below.

**Figure 65. Cover sensor with insulating tape**



**Figure 66. Sensor covered with insulating tape**



6. Repeat this procedure for Circuit 2 control wiring.

## Control Device Wiring Tables

**Note:** For most connections, existing unit wiring can be used.  
See existing unit schematic and RTAC AFD retrofit schematic.

### Circuit 1 Connections

**Table 10. Relay 1K20, 2-compressor units**

Terminal Relay 1K20	Description	Mating Connection	Description	Notes
9/11	N.C. Contact	1TB5 1-8	115 V Hot	
1/12	N.C. Contact	3HR1	Heater - Compressor 1A	
		3HR2	Heater - Oil Separator Circuit 2	
10/21	N.O. Contact	1TB5 1-8	115 V Hot	Main Panel Ventilation may not be installed, check unit configuration.
6/24	N.O. Contact	1TS4	Temp Switch Main Panel Ventilation	
11/31	N.O. Contact	1TB5 1-8	115 V Hot	
7/34	N.O. Contact	3TS1	Temp Switch 1U1 AFD Enclosure	
13/A1	Coil - Hot	Pin 4, 1U1 AFD	AFD Running Relay	
14/A2	Coil - Neut	1TB5 9-16	115 V Neutral	

**Table 11. Relay 1K20, 3 or 4-compressor units**

Terminal Relay 1K20	Description	Mating Connection	Description	Notes
9/11	N.C. Contact	1TB5 1-8	115 V Hot	
1/12	N.C. Contact	3HR1	Heater - Compressor 1A	
		1K5 Aux 4	Controls Heater - 3HR2	
10/21	N.O. Contact	1TB5 1-8	115 V Hot	Main Panel Ventilation may not be installed, check unit configuration.
6/24	N.O. Contact	1TS4	Temp Switch Main Panel Ventilation	
11/31	N.O. Contact	1TB5 1-8	115 V Hot	
7/34	N.O. Contact	3TS1	Temp Switch 1U1 AFD Enclosure	
12/41	N.O. Contact	TB5 1-8	115 V Hot	
		1K5 Aux 5	115 V Hot	
8/44	N.O. Contact	3L7	Oil Line Valve, Compressor 1A	Oil Line Valves may not be installed, check unit configuration.
		1K5 Aux 5	Controls 3L8 - Oil Line Valve, Compressor 1B	
13/A1	Coil - Hot	Pin 4, 1U1 AFD	AFD Running Relay	
14/A2	Coil - Neut	1TB5 9-16	115 V Neutral	

**Table 12. Relay 1K30, all units**

Terminal Relay 1K30	Description	Mating Connection	Description
9/11	N.O.Contact	Pin 12, 1U1 AFD	12 volt output
5/14	N.O.Contact	Pin 37, 1U1 AFD	AFD Safe Stop
13/A1	Coil - Hot	3PS1	High Pressure Cutout Circuit 1 N.C. (BLK Wire)
14/A2	Coil - Neutral	1TB5 9-16	115 V Neutral

**Table 13. 3B20, 1U1 AFD enclosure fan, all units**

Terminal 3B20	Description	Mating Connection	Description
3TS1	Temp Switch, AFD Enclosure	Pin 1, 3B20	AFD Enclosure Fan
1TB5 9-16	115 V Neutral	Pin 2, 3B20	AFD Enclosure Fan



## Installation – Electrical

**Table 14. 1U1 AFD, all units**

Terminal - AFD	Description	Mating Connection	Description
Pin 61	Modbus (RS485) Com (BLK)	Pin 2 (IMC1) Symbio™ 800	Modbus (RS485) Com (BLK)
Pin 68	Modbus (RS485) + (BLU)	Pin 3 (IMC1) Symbio 800	Modbus (RS485) + (BLU)
Pin 69	Modbus (RS485) - (GRY)	Pin 4 (IMC1) Symbio 800	Modbus (RS485) - (GRY)
Pin 4	Running Relay	13/A1, 1K20 Relay	Coil, 115 V Hot
Pin 5	Running Relay	1TB5 1-8	115 V Hot
Pin 12	24 V Output	9/11, 1k30	N.O. Contact 1k 30 Relay
Pin 37	Safe Stop	5/14, 1K30	N.O. Contact 1K30 Relay

**Table 15. 1T9 power transformer, 3 or 4-compressor units**

Terminal	Description	Mating Connection	Description
1	Voltage out	U19, J5, Pin 1	Under/Over Voltage Detection input
2	Voltage out	U19, J5, Pin 2	Under/Over Voltage Detection input

### Circuit 2 Connections

**Table 16. Relay 2K20, 2-compressor units**

Terminal Relay 2K20	Description	Mating Connection	Description	Notes
9/11	N.C. Contact	1TB5 1-8	115 V Hot	
1/12	N.C. Contact	4HR1	Heater - Compressor 2A	
		4HR2	Heater - Oil Separator Circuit 2	
10/21	N.O. Contact	1TB5 1-8	115 V Hot	Main Panel Ventilation may not be installed, check unit configuration.
6/24	N.O. Contact	1TS4	Temp Switch Main Panel Ventilation	
11/31	N.O. Contact	1TB5 1-8	115 V Hot	
7/34	N.O. Contact	4TS1	Temp Switch 2U1 AFD Enclosure	
13/A1	Coil - Hot	Pin 4, 2U1 AFD	AFD Circuit 2 Running Relay	
14/A2	Coil - Neut	1TB5 9-16	115 V Neutral	

**Table 17. Relay 2K20, 3-compressor units**

Terminal Relay 2K20	Description	Mating Connection	Description	Notes
9/11	N.C. Contact	1TB5 1-8	115 V Hot	
1/12	N.C. Contact	4HR1	Heater - Compressor 1A	
		4HR2	Heater - Oil Separator Circuit 1	
11/31	N.O. Contact	1TB5 1-8	115 V Hot	
7/34	N.O. Contact	4TS1	Temp Switch 2U1 AFD Enclosure	
13/A1	Coil - Hot	Pin 4, 2U1 AFD	AFD Circuit 2Running Relay	
14/A2	Coil - Neut	1TB5 9-16	115 V Neutral	

**Table 18. Relay 2K20, 4-compressor units**

Terminal Relay 2K20	Description	Mating Connection	Description	Notes
9/11	N.C. Contact	1TB5 1-8	115 V Hot	
1/12	N.C. Contact	4HR1	Heater - Compressor 1A	
		4HR2	Heater - Oil Separator Circuit 1	
10/21	N.O. Contact	1TB5 1-8	115 V Hot	Control Panel Ventilation may not be installed, check unit configuration.

**Table 18. Relay 2K20, 4-compressor units (continued)**

Terminal Relay 2K20	Description	Mating Connection	Description	Notes
6/24	N.O. Contact	2TS4	Temp Switch, Control Panel 2 Ventilation	
11/31	N.O. Contact	1TB5 1-8	115 V Hot	
7/34	N.O. Contact	4TS1	Temp Switch 2U1 AFD Enclosure	
13/A1	Coil - Hot	Pin 4, 2U1 AFD	AFD Circuit 2Running Relay	
14/A2	Coil - Neut	1TB5 9-16	115 V Neutral	

**Table 19. Relay 2K30, all units**

Terminal Relay 2K30	Description	Mating Connection	Description
9/11	N.O.Contact	Pin 12, 2U1 AFD	12 volt output
5/14	N.O.Contact	Pin 37, 2U1 AFD	AFD Safe Stop
13/A1	Coil - Hot	4PS1	High Pressure Cutout Circuit 2, N.C. (BLK Wire)
14/A2	Coil - Neut	1TB5 9-16	115 V Neutral

**Table 20. 4B20, 2U1 AFD enclosure fan, all units**

Terminal - AFD	Description	Mating Connection	Description
4TS1	Temp Switch AFD Enclosure	Pin 1, 4B20	AFD Enclosure Fan
1TB5 9-16	115 V Neutral	Pin 2, 4B20	AFD Enclosure Fan

**Table 21. 2U1 AFD, all units**

Terminal - AFD	Description	Mating Connection	Description
Pin 61	Modbus (RS485) Com (BLK)	Pin 2 (IMC2) Symbio 800	Modbus (RS485) Com (BLK)
Pin 68	Modbus (RS485) + (BLU)	Pin 3 (IMC2) Symbio 800	Modbus (RS485) + (BLU)
Pin 69	Modbus (RS485) - (GRY)	Pin 4 (IMC2) Symbio 800	Modbus (RS485) - (GRY)
Pin 4	Running Relay	13/A1, 2K20 Relay	Coil, 115 V Hot
Pin 5	Running Relay	1TB5 1-8	115 V Hot
Pin 12	24 Volt Output	9/11, 2k30	N.O. Contact 1k 30 Relay
Pin 37	Safe Stop	5/14, 2K30	N.O. Contact 1K30 Relay

# Symbio 800 Software Installation and Configuration

**Important:** Prior to performing steps below, ensure that retrofits outlined in service bulletin TACSV023\*-EN (for units with design sequence A0 through V0) or RTAC-SVC026\*-EN (for units with design sequence W0 through Z0) has been completed.

## Reference Documents

- RCDB - Symbio 800 Control Upgrade Kit For RTAC Rotary Chiller Installation Instructions (SO-SVN059\*-EN)
- RCDB - Symbio 800 Control Upgrade Kit For RTAC RCDA Rotary Chiller Installation Instructions (SO-SVN060\*-EN)

1. Obtain a working AC power adapter with which to power the technician laptop.

2. Connect the computer with the Tracer TU service tool software to the service port of the Tracer Symbio 800 controller with a USB type A/B cable.

3. Open Tracer TU.

**Note:** Tracer TU not scheduled to have feature used in Step 6 before August 2022. If not available, the unit parameters will need to be manually loaded from saved chiller service report.

4. Obtain the latest Symbio 800 firmware from the Trane software download site.

5. Upgrade controller firmware as follows:

- In the Utilities menu, select **File Transfer Utility**.
- In the File Transfer dialog box, select **Symbio 800 controller**, and click **Next**.
- Browse to the firmware file and click **Next**.
- Click **Start**.
- When upgrade is complete, click **Finish**.

Figure 67. Application software download



6. Tracer TUs Configuration tab appears; refer to figure below.

- Click the **Equipment Utility** tab (the wrench symbol on the right-hand side of the screen).
- Click the **Configuration** tab.

c. Click the **Starter** and select starter type as **TR200 Modbus AFD**.

d. Enter the **Compressor Rated Load Amps** value as Trane Motor Controller nameplate's Output Current.

e. Click the **Save** tab.

Figure 68. Software configuration

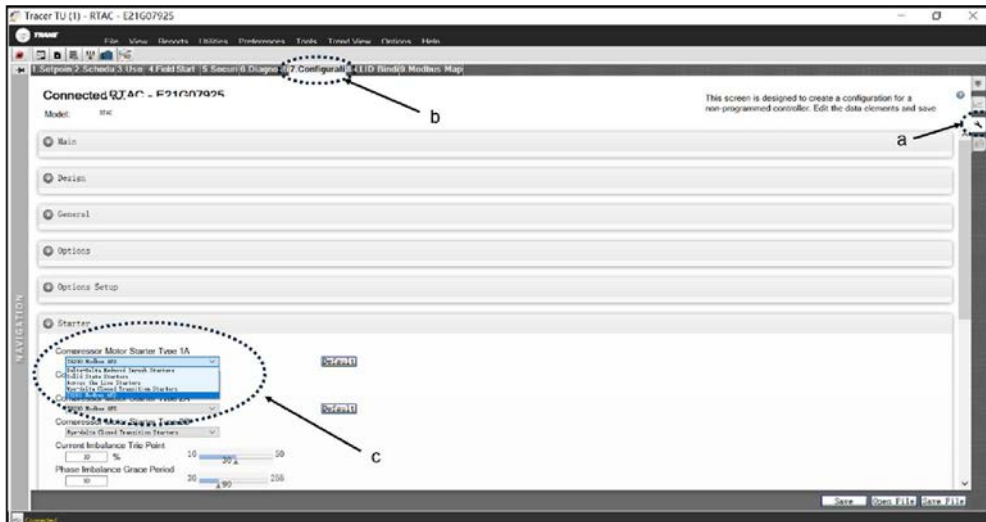

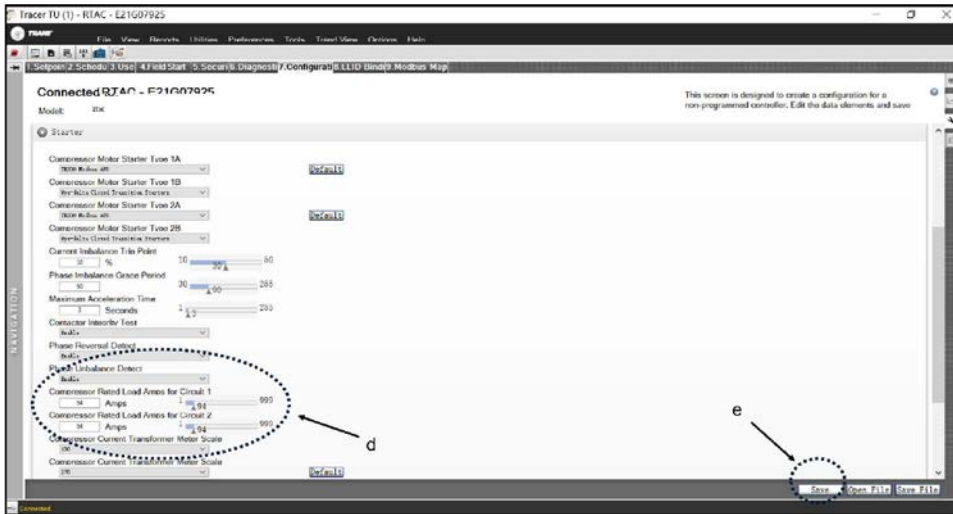

- After the configuration is saved, Tracer TU will navigate to LLID Binding view. Check for red boxes, which indicate a listed device has not been bound.

Figure 69. Binding view of LLIDs

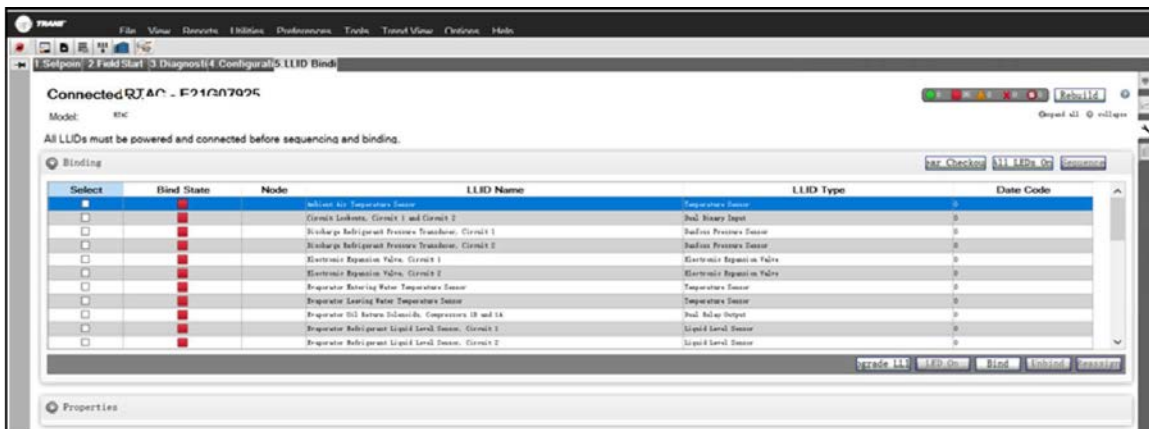



## Drive Settings

**Important:** Any AFDW drive module menu parameter numbers not listed in this manual are non-Trane specific program parameters. All non-Trane specific program parameter values have been set by the manufacturer before shipment, to provide optimum drive performance. Under no circumstances should any of the pre-set values in these menu parameters be changed unless specifically directed to do so by a factory engineer or a factory technical support person.

**Note:** See TR200 - Programming Guide (BAS-SVP04\*-EN), for more information.

Refer to Table 22, p. 40 for frequency drive settings required at start-up. For additional information, see the programming manual shipped with the drive including a detailed section describing access to parameters.

This process is summarized as follows:

1. To access the parameters, press **Main Menu**
2. If required, enter password (**999**)
3. To select a parameter group, use the up/down arrow keys to highlight the parameter group, and press **Enter**
4. Use the up/down arrow keys to access the parameter number, and press **OK**
5. Use the up/down arrow keys to change the parameter, and press **OK**.

## Retrofit Air-Cooled RTAC Adaptive Frequency Drive Model AFDW (TR200)

### NOTICE

#### Compressor Damage!

Improper drive parameter settings could cause compressor damage or failure. Verify drive parameters are set correctly prior to unit operation.

### Installation and Start-Up

Most drive parameters are set up when the drive is shipped except for a short list of unit-specific parameters obtained from the unit and motor nameplates that need to be field programmed. These require field programming.

**Important:** Do NOT change the 0-03 Regional settings parameter from the default North American category.

**Table 22. Compressor specific parameters (motor frame/voltage/Hertz)**

ID	Description	Compressor Size <sup>(a)</sup>			
		M1 or M3	M2 or M4	N1, N3 or N5	N2, N4 or N6
1-21	Motor Power (HP)	122	144	177	209
1-22	Motor Voltage (V)	460	460	460	460
1-24	Motor Current (A)	128	151	183	220
1-25	Motor Nom Speed (rpm)	3502	3494	3494	3466
14-11	Volt at Mains Fault (V)	391	391	391	391

(a) Compressor sizes are stamped on the compressor house.

See Table 23, p. 40 for a list of items that are programmed in the drive at the factory. If the drive needs to be reset, these parameters must be reprogrammed.

To reset the drive to Danfoss defaults:

1. Disconnect power to the drive, and wait for the display to shutdown.
2. While powering up the drive, press and hold the following keys: **Status**, **Main**, and **OK**.
3. After 5 seconds, release the keys.

After the drive is reset, reprogram the items listed in Table 23, p. 40.

**Important:**

- These parameters should be set at the factory to the Trane-specific values shown in Table 23, p. 40. Always confirm before actual drive start-up that settings are correct.
- Set parameter 8-30 first before setting the other 8-xx parameters.

**Table 23. Non-compressor specific parameters**

ID	Description	Values
0-03	Region Settings	[1] North American
0-20	Display Line 1.1 Small	[1612] Motor Voltage
0-24	Display Line 3 Large	[1617] Speed [RPM]
0-40	[Hand on] Key on LCP	[0] Disabled
0-41	[Off] Key on LCP	[0] Disabled
0-60	Main Menu Password	999
0-61	Access to Main Menu w/o Password	[1] LCP: Read Only
1-03	Torque Characteristics	[0] Compressor Torque
1-21	Motor Power	See Table 22, p. 40.
1-22	Motor Voltage	See Table 22, p. 40.
1-23	Motor Frequency	60Hz
1-24	Motor Current	See Table 22, p. 40.
1-25	Motor Nominal Speed	See Table 22, p. 40.
1-71	Start Delay	2.0s
1-73	Flying Start	[0] Disabled
1-78	Compressor Start Max Speed [Hz]	30Hz
1-79	Compressor Start Max Time to Trip	10s
1-82	Min Speed for Function at Stop [Hz]	10Hz
1-87	Trip Speed Low [Hz]	25Hz



**Table 23. Non-compressor specific parameters**

ID	Description	Values
3-02	Min Reference	30Hz
3-41	Ramp 1 Ramp Up Time	5s
3-42	Ramp 1 Ramp Down Time	5s
4-10	Motor Speed Direction	[0] Clockwise
4-12	Motor Speed Low Limit [Hz]	30Hz
4-18	Current Limit	128%
4-19	Max Output Frequency	61Hz
5-400	Function Relay 1	[5]Running
5-410	On Delay Relay 1	1s
5-420	Off Delay Relay 1	1s
<b>8-30<sup>(a)</sup></b>	<b>Protocol</b>	<b>[2] Modbus® RTU</b>
8-01	Control Site	[2] Controlword only
8-03	Control Timeout Time	15.0s
8-04	Control Timeout Function	[2] Stop
8-31	Address	Ckt 1 AFD = 3 Ckt 2 AFD = 4
8-32	Baud Rate	[7] 115200 Baud
14-03	Overmodulation	[0] Off
14-10	Mains Failure	[4] Kinetic Back-up
14-11	Main Voltage at Mains Fault	See <a href="#">Table 22, p. 40</a> .
14-20	Reset Mode	[1] Automatic Reset x 1
14-30	Current Lim Ctrl. Proportional Gain	25
14-31	Current Lim Ctrl Integration Time	1s
14-50	RFI Filter	[0] Off
14-51	DC Link Compensation	[1] On
22-75	Short Cycle Protection	[1] Enabled
22-78	Interval Between Starts	60s

(a) Set parameter 8-30 **BEFORE** setting the other 8-xx parameters.



# Chiller Setting Logs

**Note:** For start-up procedure, see Series R® Air-Cooled Helical Rotary Liquid Chillers, Model RTAC Installation, Operation, and Maintenance (RTAC-SVX01\*-EN).

## Start-Up Test Log

**Table 24. RTAC start-up test log**

RTAC START-UP TEST LOG			
Model #			
Job Name		Job Location	
CRC #		Serial #	
Sales Order #	Ship Date	Job Elevation (ft. above sea level)	
<b>Starter Data:</b>		<b>Start-up Only</b>	
Manufacturer		Chiller Appearance on arrival:	
Type: (wye-delta or x-line)		Machine gauge pressure:	ckt1/ckt2
Vendor ID #/ Model #:		Machine CH.530 pressure	ckt1/ckt2
Volts	Amps	Hz	Unit R-134a Charge lbs
<b>Compressor Data:</b>		Unit oil charge (OIL00048)	gal
Compressor A:		<b>Pressure Test (if required)</b>	
	Model #:	Vacuum after leak test= mm	
	Serial #	Standing Vacuum test= mm rise in hrs	
	RLA	<b>Current Transformers</b>	
	KW	Part number (X code and 2-digit extension)	
	Volts	X	
	HZ	X	
Compressor B:		X	
	Model #:	X	
	Serial #	X	
	RLA	X	
	KW	<b>Summary of Options Installed</b>	
	Volts	Y N	Tracer Communications Interface
	HZ	Y N	Ice Making
Compressor C:		Y N	Other
	Model #:	Y N	Other
	Serial #	Y N	Other
	RLA	Evap Design Conditions	
	KW	GPM	PSID
	Volts	Entering Water:	Leaving Water:
	HZ	% Glycol:	
Compressor D:		Type of Glycol:	
	Model #:	Evap Actual Conditions	
	Serial #	GPM	PSID
	RLA	Entering Water:	Leaving Water:
	KW	% Glycol:	
	Volts	Type of Glycol:	
	HZ		
Owner Witness Signature:			



# Operator Log

Table 25. RTAC operator log

RTAC CHILLER LOG						
Job Name			Job Location			
Model #			Serial #			
Status View: *						
Chiller Tab:	15 min	30 min	45 min	15 min	30 min	45 min
Operating Mode						
Outdoor Air Temperature °F or °C						
Active Chill Water Setpoint °F or °C						
Active Current Limit Setpoint						
Evaporator Entering Water Temp. °F or °C						
Evaporator Leaving Water Temp. °F or °C						
	Circuit 1 Tab			Circuit 2 Tab		
External Hardwired Lockout	Not Locked out/ Locked out			Not Locked out/ Locked out		
Front Panel Lockout	Not Locked out/ Locked out			Not Locked out/ Locked out		
	15 min	30 min	45 min	15 min	30 min	45 min
AirFlow %						
Inverter Speed %						
Condenser Refrigerant Pressure psig/kPa						
Saturated Condenser Rfgt. Temp. °F or °C						
Differential Refrigerant Pressure psid/kPA						
Evaporator Refrigerant Pressure psig/kPa						
Saturated Evaporator Rfgt. Temp. °F or °C						
EXV Position %						
Evaporator Rfgt Liquid Level in/mm						
	Compressor 1A Tab			Compressor 1B Tab		
Operating Mode						
Hours	Hrs/mins			Hrs/mins		
Starts						
	15 min	30 min	45 min	15 min	30 min	45 min
Phase A - B Voltage volts						
Average Line Current %RLA						
Line 1 current amps						
Line 2 current amps						
Line 3 current amps						
Line 1 current %RLA						
Line 2 current %RLA						
Line 3 current %RLA						
Evaporator Oil Return Solenoid	open/closed	open/closed	open/closed	open/closed	open/closed	open/closed
Supply Oil Temperature °F or °C						
Intermediate Oil Pressure psig/kPa						
Female Step solenoid	load/unload	load/unload	load/unload	load/unload	load/unload	load/unload
High Pressure Cutout switch	good/tripped	good/tripped	good/tripped	good/tripped	good/tripped	good/tripped
Comments:						



## Chiller Setting Logs

**Table 25. RTAC operator log (continued)**

RTAC CHILLER LOG						
	Compressor 2A Tab			Compressor 2B Tab		
Operating Mode						
Hours	Hrs/mins			Hrs/mins		
Starts						
	15 min	30 min	45 min	15 min	30 min	45 min
Phase A - B Voltage	volts					
Average Line Current	%RLA					
Line 1 current	amps					
Line 2 current	amps					
Line 3 current	amps					
Line 1 current	%RLA					
Line 2 current	%RLA					
Line 3 current	%RLA					
Evaporator Oil Return Solenoid	open/closed	open/closed	open/closed	open/closed	open/closed	open/closed
Supply Oil Temperature	°F or °C					
Intermediate Oil Pressure	psig/kPa					
Female Step solenoid	load/unload	load/unload	load/unload	load/unload	load/unload	load/unload
High Pressure Cutout switch	good/tripped	good/tripped	good/tripped	good/tripped	good/tripped	good/tripped
Comments:						



# Troubleshooting

The drive displays three types of faults:

- **Warning**

A warning or alarm is signaled by the LEDs on the front of the AFD by a code on the LCP.

A warning indicates a condition that may require attention or a trend that may eventually require attention, and will remain active until the cause is no longer present. Under some circumstances, motor operation may continue.

- **Trip**

A trip is the action when an alarm has appeared. The trip removes power to the motor and, after the condition has been cleared, can be reset by pressing the **Reset** button. The event that caused an alarm cannot damage the AFD or cause a dangerous condition.

After its cause has been rectified, an alarm must be reset to restart operation.

- **Trip Lock**

A trip lock is an action when an alarm occurs that may cause damage to the AFD or equipment. Power is removed from the motor, and a trip lock can only be reset after the condition is cleared by cycling power.

Once the problem has been rectified, only the alarm continues flashing until the AFD is reset.

- a. Note the following chiller information:
    - Operating mode and any sub-mode (i.e., 100 percent or 75 percent load etc.).
    - Number of chiller starts, and hours of operation.
    - Time since last diagnostic shutdown (<1 minute, <1 hour, >1 hour, etc.).
  - b. What was the chiller state at the time of the failure? (Chiller starting? Running low load? Running full load? etc.).
  - c. Record the chiller's sales order and serial numbers, & the drive's serial and model numbers.
3. Troubleshooting.
- a. Measure and record the DC bus (via the Local Control Panel [LCP]).
  - b. Check ALL wiring (tightness, ribbon cables fully seated, proper phasing, etc.).
  - c. Refer to the Danfoss manuals for further troubleshooting information.

## WARNING

### Hazardous Voltage w/Capacitors!

**Failure to disconnect power and discharge capacitors before servicing could result in death or serious injury. Disconnect all electric power, including remote disconnects and discharge all motor start/run capacitors before servicing. Follow proper lockout/tagout procedures to ensure the power cannot be inadvertently energized. For variable frequency drives or other energy storing components provided by Trane or others, refer to the appropriate manufacturer's literature for allowable waiting periods for discharge of capacitors. Verify with a CAT III or IV voltmeter rated per NFPA 70E that all capacitors have discharged.**

1. **Tracer AdaptiView™ only:** Collect alarm and parameter information.
  - a. DO NOT cycle unit power or reset the controls. Leave the AFD and the Symbio™ 800 in their present states.
  - b. Record all Symbio 800 active and historic alarms. Make a full chiller service report.
  - c. Document and check all applicable parameter settings. This information can be verified off of the chiller nameplate, and by referring to this manual.
  - d. In the Binding view of the Tracer® TU service tool, verify a green face indicating that the Starter LLID is bound.
  - e. Record any drive diagnostics found.
2. Collect Chiller Information.



# Recommended Annual Maintenance and Inspection

The inspections in this must be performed annually. Inspections can be performed more frequently if required by operating environment.

## Visual Inspection — Power Removed

### ⚠ WARNING

#### Hazardous Voltage with Capacitors!

Failure to disconnect power and discharge capacitors before servicing could result in death or serious injury. Disconnect all electric power, including remote disconnects and discharge all motor start/run capacitors before servicing. Follow proper lockout/tagout procedures to ensure the power cannot be inadvertently energized. For variable frequency drives or other energy storing components provided by Trane or others, refer to the appropriate manufacturer's literature for allowable waiting periods for discharge of capacitors. Verify with a CAT III or IV voltmeter rated per NFPA 70E that all capacitors have discharged.

1. Verify the door interlocks are present and working.
2. Verify the safety ground connections to the door panels are securely connected.
3. Inspect power wire cables and devices to assure no abrasion is occurring from vibrations against chassis of cabinets, or other edges.
4. Confirm the drive interior and exterior is clear of any dust or debris. Fans, circuit boards, vents, etc. must be clean. Only use a vacuum for cleaning. Do NOT use compressed air.
5. Inspect the interior of the drive for any signs of moisture entry or leakage.
6. Visually inspect all drive components and wiring. Look for signs of heat or failure (look for swelled or leaking capacitors, discolored reactors or inductors, broken pre-charge resistors, smoke or arc trails on MOVs and capacitors, etc.).
7. Closely inspect the motor terminal board for any signs of leakage, arcing, etc.
8. Check ALL cable/lug/terminal connections inside the drive enclosure. Ensure all are clean and tight, and not rubbing against each other anywhere.

## Operational Inspection — Power Applied

### ⚠ WARNING

#### Live Electrical Components!

Failure to follow all electrical safety precautions when exposed to live electrical components could result in death or serious injury.

When it is necessary to work with live electrical components, have a qualified licensed electrician or other individual who has been properly trained in handling live electrical components perform these tasks.

1. Verify the drive cabinet cooling fans are operating. This should be done from outside the enclosure, by looking into the cabinet at door and cabinet vents, to avoid electrical hazards.  
*Note: The power module fan comes on with power. Other fans cycle with drive operation.*
2. Check historic fault codes using LCP connected to the AFD.
3. Check configuration settings and confirm all proper settings are still present in the controls.
4. Review the diagnostic history.
5. Make Chiller Service report to document all setpoints.
6. Check the Symbio™ 800 alarm histories for any indications of operational problems.

### Do this Every 1–12 Months depending on Operating Environment

To properly diagnose service issues for Adaptive Frequency Drives for chillers equipped with AFDW starters, all Symbio 800 chillers will be equipped with the LCP as standard on the drive power module. This is for service only and NEVER for machine operation.



# Wiring Information

## Wiring Diagram Matrix

**Table 26. Wiring diagrams**

Wiring Diagram Number	Description
5071-3116	RTAC AFD Retrofit for Symbio™ 800 Controls, 2-Compressor Schematic
5071-3117	RTAC AFD Retrofit for Symbio 800 Controls, 3-Compressor Schematic
5071-3118	RTAC AFD Retrofit for Symbio 800 Controls, 4-Compressor Schematic

**Note:** Wiring diagrams are available via e-Library.

# Field Wiring

Figure 70. Field wiring connections<sup>(a)</sup>

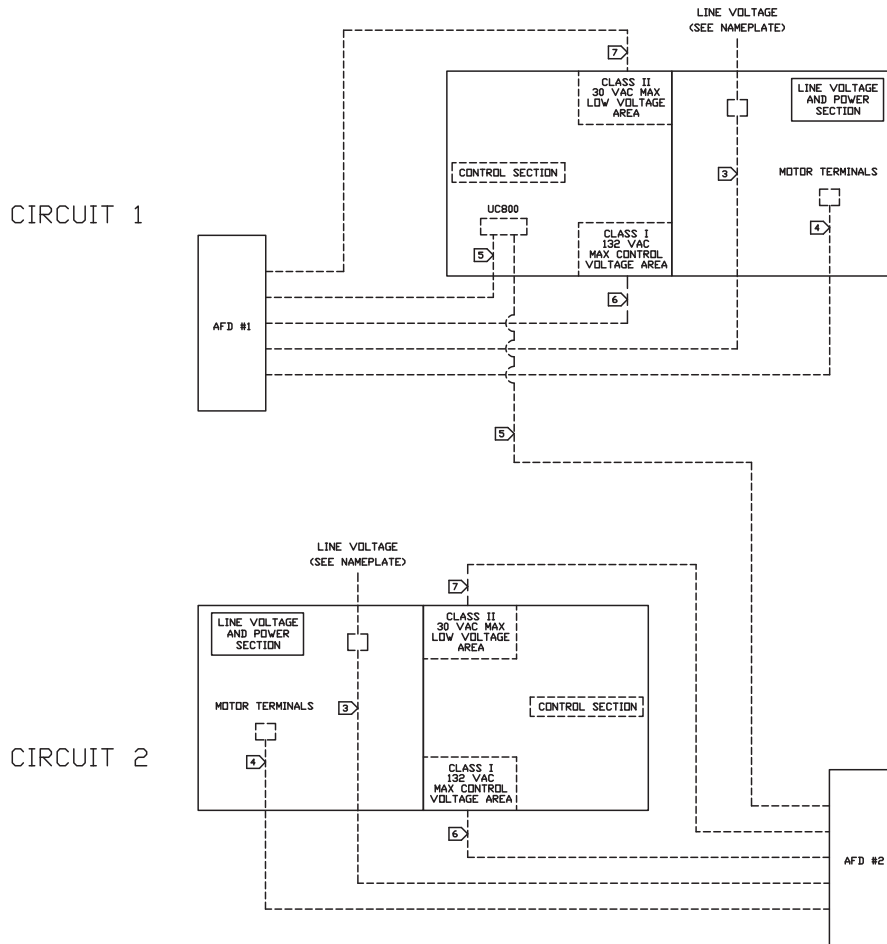

NOTES:

1. DASHED LINES INDICATE FIELD WIRING BY OTHERS. PHANTOM LINES INDICATE ALTERNATE CIRCUITRY OR AVAILABLE SALES OPTIONS. CHECK SALES ORDER TO DETERMINE IF WIRING IS REQUIRED FOR SPECIFIC OPTIONS.
2. ALL FIELD WIRING MUST BE IN ACCORDANCE WITH THE NATIONAL ELECTRIC CODE AND STATE AND LOCAL REQUIREMENTS. EXPORT UNIT WIRING MUST COMPLY WITH LOCAL APPLICABLE CODES.
- ③ POWER WIRE - LINE VOLTAGE INTO AFD.
- ④ POWER WIRE - LINE VOLTAGE AFD TO MOTOR.
- ⑤ CONTROL WIRE - MODBUS.  
GLOBAL HARNESS - 4 CONDUCTOR 18 AWG TWISTED PAIR.
- ⑥ CONTROL WIRE - 30 VAC MAX,  
2 SINGLE CONDUCTOR CABLES, 16 AWG UL 1230.
- ⑦ CONTROL WIRE - 132 VAC MAX,  
2 SINGLE CONDUCTOR CABLES, 16 AWG UL 1230.

(a) See "Control Device Wiring Tables," p. 35 for connections. See tables in section "Parts," p. 10 for harness part numbers.







## Notes

---



Trane - by Trane Technologies (NYSE: TT), a global climate innovator - creates comfortable, energy efficient indoor environments for commercial and residential applications. For more information, please visit [trane.com](http://trane.com) or [tranetechnologies.com](http://tranetechnologies.com).

Trane has a policy of continuous product and product data improvement and reserves the right to change design and specifications without notice. We are committed to using environmentally conscious print practices.