



Installation Instructions

Variable Frequency Drive

Conversion TR1 to TR200

Commercial Self Contained Signature and
Modular Series Units



Model Numbers: Units with factory installed VFDs and units with VFD or VFD with bypass options:

S**F 20 to 110 tons

S**G 30 to 35 tons

This document applies to service offering applications only.

SAFETY WARNING

Only qualified personnel should install and service the equipment. The installation, starting up, and servicing of heating, ventilating, and air-conditioning equipment can be hazardous and requires specific knowledge and training. Improperly installed, adjusted or altered equipment by an unqualified person could result in death or serious injury. When working on the equipment, observe all precautions in the literature and on the tags, stickers, and labels that are attached to the equipment.



Introduction

Read this manual thoroughly before operating or servicing this unit.

Warnings, Cautions, and Notices

Safety advisories appear throughout this manual as required. Your personal safety and the proper operation of this machine depend upon the strict observance of these precautions.

The three types of advisories are defined as follows:

- WARNING** Indicates a potentially hazardous situation which, if not avoided, could result in death or serious injury.
- CAUTION** Indicates a potentially hazardous situation which, if not avoided, could result in minor or moderate injury. It could also be used to alert against unsafe practices.
- NOTICE** Indicates a situation that could result in equipment or property-damage only accidents.

Important Environmental Concerns

Scientific research has shown that certain man-made chemicals can affect the earth's naturally occurring stratospheric ozone layer when released to the atmosphere. In particular, several of the identified chemicals that may affect the ozone layer are refrigerants that contain Chlorine, Fluorine and Carbon (CFCs) and those containing Hydrogen, Chlorine, Fluorine and Carbon (HCFCs). Not all refrigerants containing these compounds have the same potential impact to the environment. Trane advocates the responsible handling of all refrigerants.

Important Responsible Refrigerant Practices

Trane believes that responsible refrigerant practices are important to the environment, our customers, and the air conditioning industry. All technicians who handle refrigerants must be certified according to local rules. For the USA, the Federal Clean Air Act (Section 608) sets forth the requirements for handling, reclaiming, recovering and recycling of certain refrigerants and the equipment that is used in these service procedures. In addition, some states or municipalities may have additional requirements that must also be adhered to for responsible management of refrigerants. Know the applicable laws and follow them.

WARNING

Proper Field Wiring and Grounding Required!

Failure to follow code could result in death or serious injury. All field wiring **MUST** be performed by qualified personnel. Improperly installed and grounded field wiring poses **FIRE** and **ELECTROCUTION** hazards. To avoid these hazards, you **MUST** follow requirements for field wiring installation and grounding as described in **NEC** and your local/state/national electrical codes.

WARNING

Personal Protective Equipment (PPE) Required!

Failure to wear proper PPE for the job being undertaken could result in death or serious injury. Technicians, in order to protect themselves from potential electrical, mechanical, and chemical hazards, **MUST** follow precautions in this manual and on the tags, stickers, and labels, as well as the instructions below:

- Before installing/servicing this unit, technicians **MUST** put on all PPE required for the work being undertaken (Examples; cut resistant gloves/sleeves, butyl gloves, safety glasses, hard hat/bump cap, fall protection, electrical PPE and arc flash clothing). **ALWAYS** refer to appropriate Safety Data Sheets (SDS) and OSHA guidelines for proper PPE.
- When working with or around hazardous chemicals, **ALWAYS** refer to the appropriate SDS and OSHA/GHS (Global Harmonized System of Classification and Labeling of Chemicals) guidelines for information on allowable personal exposure levels, proper respiratory protection and handling instructions.
- If there is a risk of energized electrical contact, arc, or flash, technicians **MUST** put on all PPE in accordance with OSHA, NFPA 70E, or other country-specific requirements for arc flash protection, **PRIOR** to servicing the unit. **NEVER PERFORM ANY SWITCHING, DISCONNECTING, OR VOLTAGE TESTING WITHOUT PROPER ELECTRICAL PPE AND ARC FLASH CLOTHING. ENSURE ELECTRICAL METERS AND EQUIPMENT ARE PROPERLY RATED FOR INTENDED VOLTAGE.**

⚠ WARNING**Follow EHS Policies!**

Failure to follow instructions below could result in death or serious injury.

- All Trane personnel must follow the company's Environmental, Health and Safety (EHS) policies when performing work such as hot work, electrical, fall protection, lockout/tagout, refrigerant handling, etc. Where local regulations are more stringent than these policies, those regulations supersede these policies.
- Non-Trane personnel should always follow local regulations.

Copyright

This document and the information in it are the property of Trane, and may not be used or reproduced in whole or in part without written permission. Trane reserves the right to revise this publication at any time, and to make changes to its content without obligation to notify any person of such revision or change.

Trademarks

All trademarks referenced in this document are the trademarks of their respective owners.

Revision History

Document updated to reflect Service Offering number.



Table of Contents

General Information	5
Tools Required	5
Removal and Replacement for S**F Units	6
Removal and Replacement for S**G Without Bypass	9
Removal and Replacement for S**G With Bypass	
11	
TR200 VFD Programming Information	13



General Information

The instructions in this manual describe procedures required to successfully retrofit a TR1 on 20 ton to 110 ton Signature Series and 20 ton to 35 ton Modular Series Commercial Self Contained (CSC) units to a Trane TR200 VFD drive. For help selecting the proper parts for this work, refer to *General Service Bulletin, VFD Selection List for TR1 to TR200* (PART-SVB25*-EN).

The instructions in this manual are divided into the following sections:

- Removal and Replacement for S**F Units
- Removal and Replacement for S**G Units without Bypass
- Removal and Replacement for S**G Units with bypass
- TR200 VFD Programming Information

Follow start-up and troubleshooting procedures outlined in the Installation, Operation, and Maintenance manuals and/or the literature included with the TR200 VFD.

Tools Required

- Very few tools are required to perform this installation.
- A service technician with a well-stocked tool chest should have the right tools to perform the job.

Removal and Replacement for S**F Units

1. Locate the existing TR1 VFD in the VFD panel on the right, front side of the CSC unit. The VFD is mounted inside this panel on a back panel. The replacement actions will consist of disconnecting wiring, removing the VFD and back panel, installing a replacement back panel, installing the new VFD, and reconnecting the wiring.

Note: For additional information regarding the safe discharge of capacitors, see *PROD-SVB06*-EN* or *PROD-SVB06*-FR*.

2. Confirm power is removed from the unit. See [Figure 1, p. 6](#) [Figure 2, p. 6](#) and [Figure 3, p. 7](#) for typical wiring diagrams for power and control signals for units with and without bypass. [Table 1, p. 7](#) lists typical control and power wires to be disconnected. Disconnect the wires and record the wire numbers as a reference to be used when reconnecting the new VFD. Units without bypass will not have all wires connected.

⚠ WARNING

Hazardous Voltage w/Capacitors!

Failure to disconnect power and discharge capacitors before servicing could result in death or serious injury. Disconnect all electric power, including remote disconnects and discharge all motor start/run capacitors before servicing. Follow proper lockout/tagout procedures to ensure the power cannot be inadvertently energized. For variable frequency drives or other energy storing components provided by Trane or others, refer to the appropriate manufacturer's literature for allowable waiting periods for discharge of capacitors. Verify with a CAT III or IV voltmeter rated per NFPA 70E that all capacitors have discharged.

Figure 1. Typical power and control wiring for S**F units without bypass

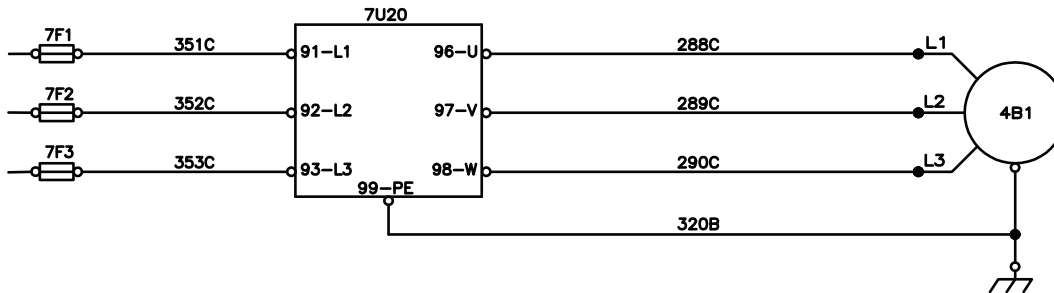

Figure 2. Typical power wiring for S**F units with bypass

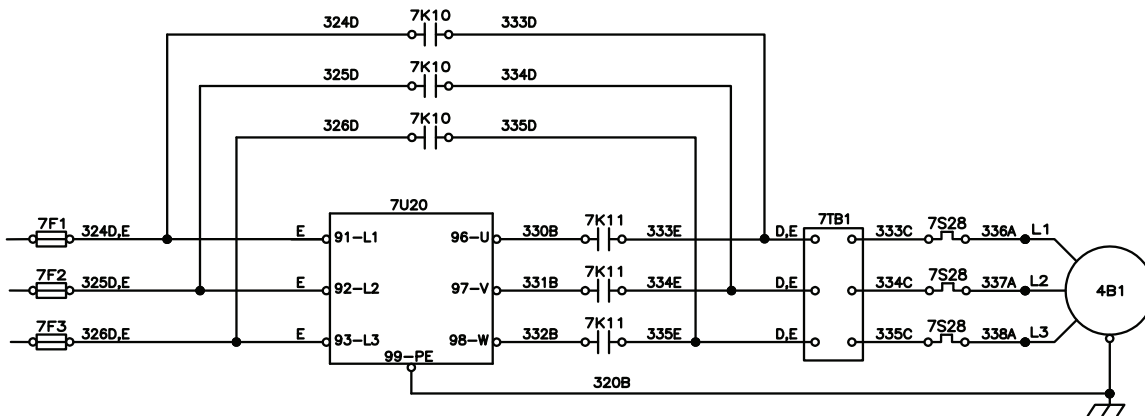

Figure 3. Typical control wiring for SF units with bypass**

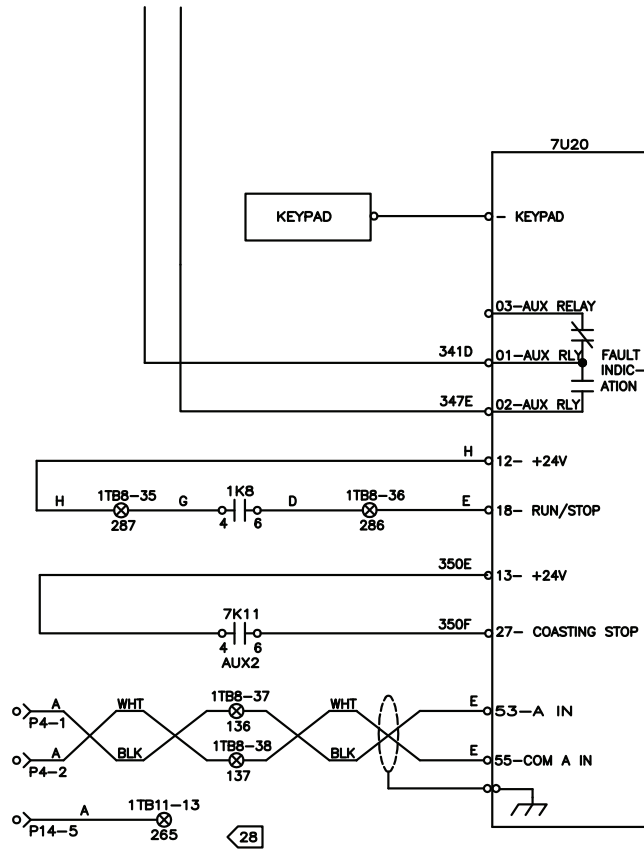

Table 1. Typical wires for SF units**

VFD Connection	Description	Wire Number
91-L1	Phase A line input	
92-L2	Phase B line input	
93-L3	Phase C line input	
99-PE	GND	
96-U	Phase A VFD output	
97-V	Phase B VFD output	
98-W	Phase C VFD output	
53 A IN	Speed reference	
55 COM A IN	Speed reference common	
Chassis Gnd	Speed reference shield	
12	+24V	
13	+24V	
18	Run/stop	
27	Coasting stop	
Keypad	Keypad	
01	Aux relay	
02	Aux relay	

3. Disconnect the power and control wires from the VFD.

⚠ WARNING

Heavy Objects!

Failure to follow instructions below could result in unit dropping which could result in death or serious injury, and equipment or property-only damage. Ensure that all the lifting equipment used is properly rated for the weight of the unit being lifted. Each of the cables (chains or slings), hooks, and shackles used to lift the unit must be capable of supporting the entire weight of the unit. Lifting cables (chains or slings) may not be of the same length. Adjust as necessary for even unit lift.

4. After all wiring has been disconnected, attach a lifting device to the VFD to support it during removal. The weight of the VFDs varies from 40 to 175 lbs. Follow safe procedures for lifting and removing the VFD and back panel assembly. Locate the six nuts holding the VFD back panel to the enclosure and remove the nuts. Save the nuts for use during mounting of the new TR200. Remove the VFD and back panel assembly.
5. Locate the new TR200 VFD and verify the part number for the replacement is correct. Refer to *General Service Bulletin, VFD Selection List for TR1 to TR200 (PART-SVB25*-EN)*.
6. Locate the new back panel in the kit. From the back of the panel, install the four screws and lock washers supplied in the kit into the threaded holes of the adapter panel that align with the mounting points on the TR200 drive.
7. Install the replacement panel in the CSC cabinet and secure to the six mounting studs with the nuts removed from the TR1 panel.
8. Weights of the replacement VFDs varies between 20 and 140 lbs. Verify the weight of the TR200 VFD prior to lifting. Using proper lifting procedures, lift the TR200 into the enclosure. Attach the TR200 drive to the replacement panel with the four KEPS nuts supplied in the kit.
9. Remove the TR1 VFD Local Control Panel (LCP) from the VFD enclosure door.
10. Install the TR200 keypad in the cutout on the enclosure door using [Figure 4, p. 8](#) as a guide.

Removal and Replacement for S**F Units

Figure 4. Typical control wiring for S**F units with bypass

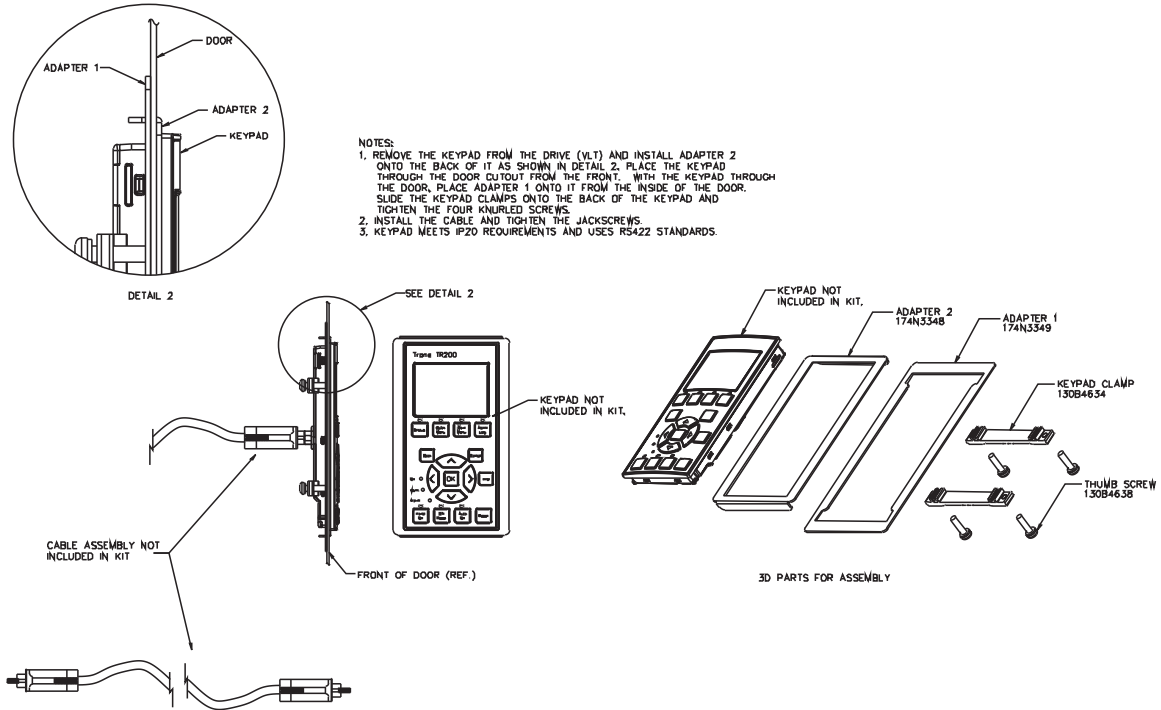

11. Reconnect the wiring to the TR200. The connection points on the TR200 VFD are the same as the connection points on the TR1 VFD although the locations of the terminals may be different.

Removal and Replacement for S**G Without Bypass

1. Locate the existing TR1 VFD. It will most likely be mounted on a wall near the CSC unit. The replacement actions will consist of disconnecting wiring, removing the VFD and back panel, installing a replacement back panel, installing the new VFD, and reconnecting the wiring. The bypass components and enclosure will remain in place.

⚠ WARNING

Hazardous Voltage w/Capacitors!

Failure to disconnect power and discharge capacitors before servicing could result in death or serious injury. Disconnect all electric power, including remote disconnects and discharge all motor start/run capacitors before servicing. Follow proper lockout/tagout procedures to ensure the power cannot be inadvertently energized. For variable frequency drives or other energy storing components provided by Trane or others, refer to the appropriate manufacturer's literature for allowable waiting periods for discharge of capacitors. Verify with a CAT III or IV voltmeter rated per NFPA 70E that all capacitors have discharged.

Note: For additional information regarding the safe discharge of capacitors, see *PROD-SVB06*-EN* or *PROD-SVB06*-FR*.

2. Confirm power is removed from the unit. See [Figure 5, p. 9](#) and [Figure 6, p. 9](#) for typical wiring diagrams for power and control signals for units without bypass. [Table 2, p. 9](#) lists typical control and power wires to be disconnected. Disconnect the wires and record the wire numbers as a reference to be used when reconnecting the new VFD.

Figure 5. Typical power wiring for SG units without bypass**

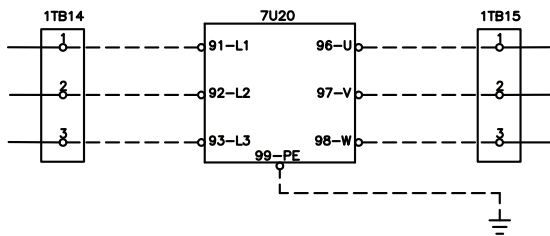

Figure 6. Typical control wiring for SG units without bypass**

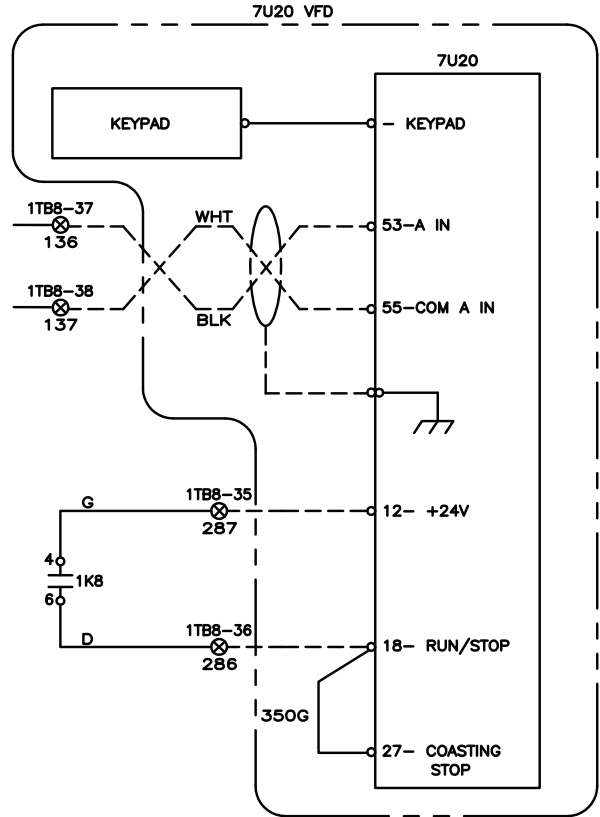

Table 2. Typical wires for SG units without bypass**

VFD Connection	Description	Wire Number
91-L1	Phase A line input	
92-L2	Phase B line input	
93-L3	Phase C line input	
99-PE	GND	
96-U	Phase A VFD output	
97-V	Phase B VFD output	
98-W	Phase C VFD output	
53 A IN	Speed reference	
55 COM A IN	Speed reference common	
Chassis Gnd	Speed reference shield	
12	+24V	
18	Run/stop	
27	Coasting stop	
Keypad	Keypad	

3. Disconnect the power and control wires from the VFD.



Removal and Replacement for S**G Without Bypass

⚠ WARNING

Heavy Objects!

Failure to follow instructions below could result in unit dropping which could result in death or serious injury, and equipment or property-only damage.

Ensure that all the lifting equipment used is properly rated for the weight of the unit being lifted. Each of the cables (chains or slings), hooks, and shackles used to lift the unit must be capable of supporting the entire weight of the unit. Lifting cables (chains or slings) may not be of the same length. Adjust as necessary for even unit lift.

4. After all wiring has been disconnected, attach a lifting device to the VFD to support it during removal. The weight of the VFDs varies from 40 to 175 lbs. Follow safe procedures for lifting and removing the VFD and back panel assembly. Locate the hardware holding the VFD to its back panel and remove the hardware. Save the hardware for use during mounting of the new VFD. Remove the VFD.
5. Locate the new TR200 VFD and verify the part number for the replacement is correct. Refer to *General Service Bulletin, VFD Selection List for TR1 to TR200 (PART-SVB25*-EN)*.
6. Locate the new back panel in the kit. From the back of the panel, install the four screws and lock washers supplied in the kit into the threaded holes of the adapter panel that align with the mounting points on the TR200 drive.
7. Attach the adapter panel to the VFD assembly mounted on the wall and secure to the existing mounting points using the TR1 mounting hardware.
8. Weights of the replacement VFDs varies between 51 and 99 lbs. Verify the weight of the VFD prior to lifting. Using proper lifting procedures lift the TR200 VFD into position. Attach the TR200 drive to the replacement panel with the four KEPS nuts supplied in the kit.
9. Reconnect the wiring to the TR200. The connection points on the TR200 VFD are the same as the connection points on the TR1 VFD although the location of the terminals may be different.



Removal and Replacement for S**G With Bypass

1. Locate the existing TR1 VFD and bypass assembly. The VFD will be replaced; all components inside and wiring to/from the bypass enclosure will not be changed.

Note: For additional information regarding the safe discharge of capacitors, see *PROD-SVB06*-EN* or *PROD-SVB06*-FR*.

2. Confirm power is removed from the unit. Disconnect the power and control wires from the VFD. See [Figure 7, p. 11](#) and [Figure 8, p. 12](#) for typical wiring diagrams for power and control signals that connect to the VFD. [Table 3, p. 12](#) lists typical control and power wires to be disconnected. Disconnect the wires and record the wire numbers as a reference to be used when reconnecting the new VFD.

⚠ WARNING

Hazardous Voltage w/Capacitors!

Failure to disconnect power and discharge capacitors before servicing could result in death or serious injury. Disconnect all electric power, including remote disconnects and discharge all motor start/run capacitors before servicing. Follow proper lockout/tagout procedures to ensure the power cannot be inadvertently energized. For variable frequency drives or other energy storing components provided by Trane or others, refer to the appropriate manufacturer's literature for allowable waiting periods for discharge of capacitors. Verify with a CAT III or IV voltmeter rated per NFPA 70E that all capacitors have discharged.

Figure 7. Typical power wiring for S**G units with bypass

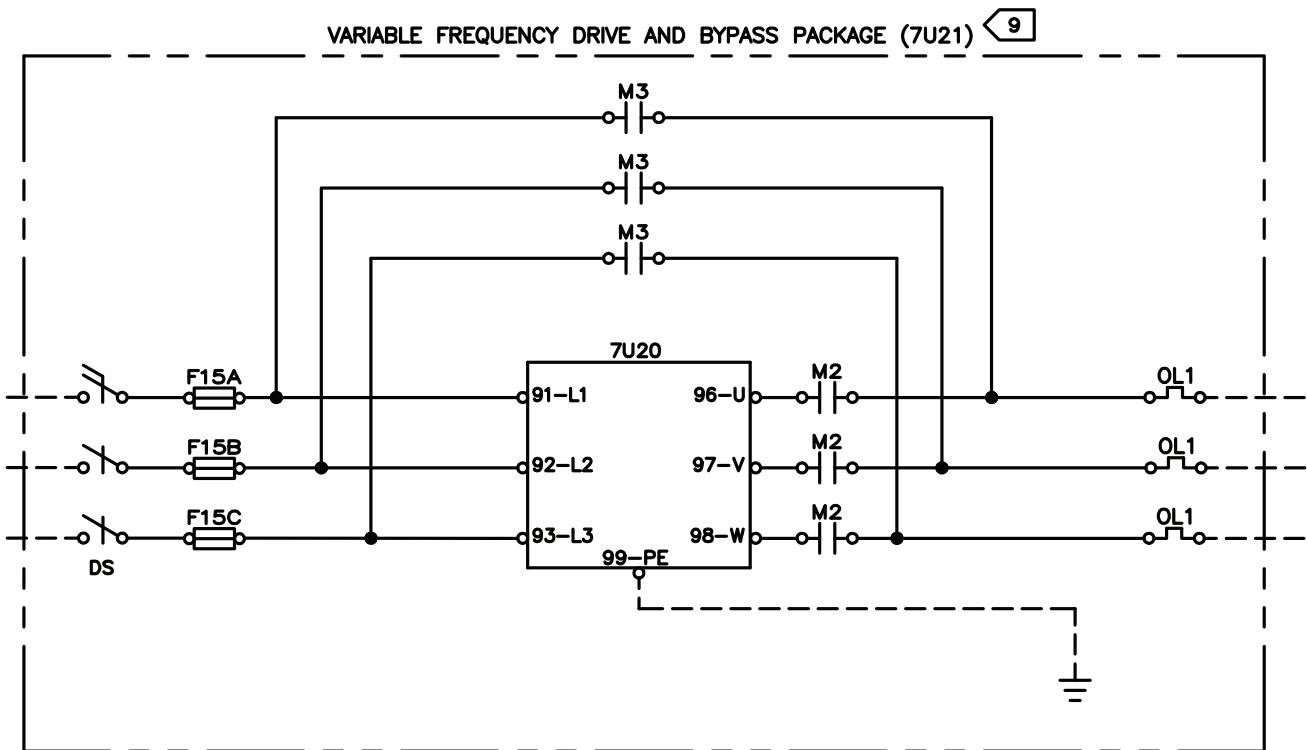

Removal and Replacement for S**G With Bypass

Figure 8. Typical control wiring for S**G units with bypass

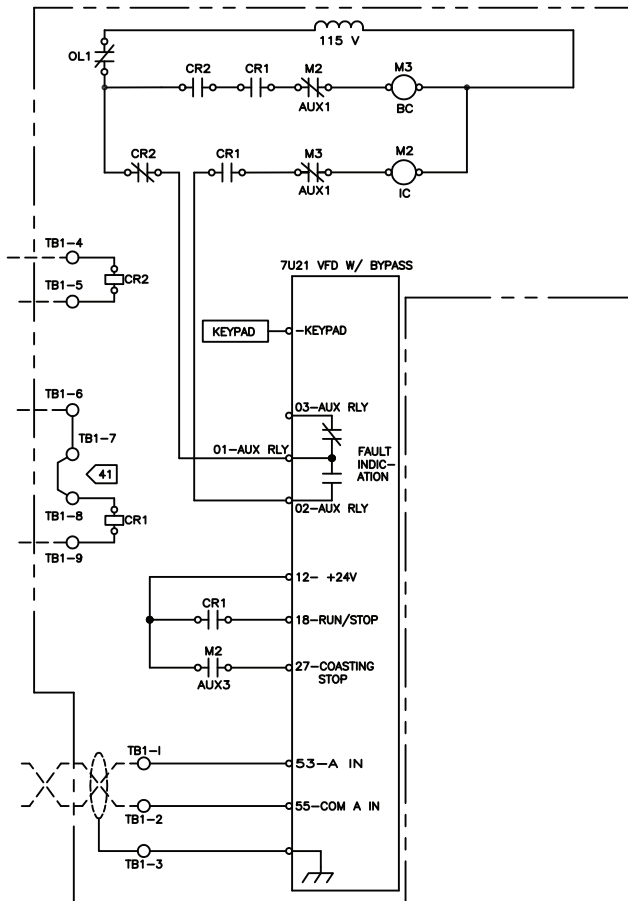

Table 3. Typical wires for S**G units with bypass

VFD Connection	Description	Wire Number
91-L1	Phase A line input	
92-L2	Phase B line input	
93-L3	Phase C line input	
99-PE	GND	
96-U	Phase A VFD output	
97-V	Phase B VFD output	
98-W	Phase C VFD output	
53 A IN	Speed reference	
55 COM A IN	Speed reference common	
Chassis Gnd	Speed reference shield	
12	+24V	
18	Run/stop	
27	Coasting stop	
Keypad	Keypad	

3. Remove the three sheet metal parts (front cover, cover support bracket, and angle bracket) enclosing the wire below the TR1 drive. Save the hardware used to attach the angle bracket to the side of the bypass enclosure.

WARNING

Heavy Objects!

Failure to follow instructions below could result in unit dropping which could result in death or serious injury, and equipment or property-only damage. Ensure that all the lifting equipment used is properly rated for the weight of the unit being lifted. Each of the cables (chains or slings), hooks, and shackles used to lift the unit must be capable of supporting the entire weight of the unit. Lifting cables (chains or slings) may not be of the same length. Adjust as necessary for even unit lift.

- After all wiring has been disconnected and the wire cover parts have been removed, attach lifting device to VFD to support it during removal. The weight of the VFDs varies from 40 to 175 lbs. Follow safe procedures for lifting and removing the VFD and back panel assembly. Locate the screws holding the VFD to its back panel and remove the screws. Save the screws for use during mounting of the new VFD. Remove the VFD.
- Locate the new TR200 VFD kit and verify the part number for the replacement is correct. Refer to *General Service Bulletin, VFD Selection List for TR1 to TR200 (PART-SVB25*-EN)*.
- From the back of the panel, install the four screws and lock washers supplied in the kit into the threaded holes of the drive adapter panel that align with the mounting points on the TR200 drive.
- Attach the adapter panel to the bypass panel and secure with the hardware removed from the TR1 drive.
- Weights of the replacement VFDs varies between 14 and 175 lbs. Verify the weight of the VFD prior to lifting. Using proper lifting procedures lift the TR200 VFD into position. Attach the TR200 drive to the adapter panel with the four KEPS nuts supplied in the kit.
- For TR200 drives below 11 amps, install the conduit adapter plate supplied in the kit over the rectangular hole on the side of the bypass enclosure using the screws removed original angle bracket. Insert three of the flexible conduit connectors supplied in the kit into the conduit adapter cover. Attach the remaining conduit connectors into the TR200 drive. Trim the flexible conduit supplied in the kit to reach between the connectors. Attach on end of the three flexible conduits tubes to the connectors on the bypass enclosure and route the input, output and control wiring through separate tubes. Attach the tubes to the connectors on the TR200 drive.
- For TR200 drives above 11 amps, install the replacement wire cover sheet metal parts supplied in the kit using the 3 to 32 thread rolling screws supplied in the kit.
- Reconnect the wiring to the TR200. The connection points on the TR200 VFD are the same as the connection points on the TR1 VFD although the location of the terminals may be different.



TR200 VFD Programming Information

The following parameters must be programmed into the VFD prior to operation. Refer to *Installation and Operation - TR200* (BAS-SVX19*-EN) for complete programming information and

instructions on how to navigate the TR200 local control panel menus.

Table 4. CSC special VFD parameter settings

Parameter	Description	Trane setting
0-01	Language	[22] English US
0-03	Regional settings	[1] North America
0-22	Display line 1.3 small	[1611] Power [hp]
1-21	Motor power [HP]	Reference motor nameplate HP
1-22	Motor voltage	Reference motor nameplate voltage
1-24	Motor current	Reference motor nameplate FLA
1-25	Motor nominal speed	Reference motor nameplate rated speed
1-73	Flying start	[1] Enabled
3-41	Ramp 1 ramp-up time	30 Sec.
3-42	Ramp 1 ramp-down time	30 Sec.
4-12	Motor speed low limit [Hz]	22 Hz
5-12	Terminal 27, digital input	[2] Coast inverse
6-14	Terminal 53 low ref./ feedb. value	22 Hz
14-01	Switching frequency	Set to max per X code drawing
14-12	Function at mains imbalance	[3] Derate
14-60	Function at over temperature	[1] Derate
14-21	Automatic restart time	3 Sec.



Notes

Trane - by Trane Technologies (NYSE: TT), a global climate innovator - creates comfortable, energy efficient indoor environments for commercial and residential applications. For more information, please visit trane.com or tranetechnologies.com.

Trane has a policy of continuous product and product data improvement and reserves the right to change design and specifications without notice. We are committed to using environmentally conscious print practices.