



Installation Instructions

Series R® Heat Pump Chiller

Model RTZA

Disassembly Instructions

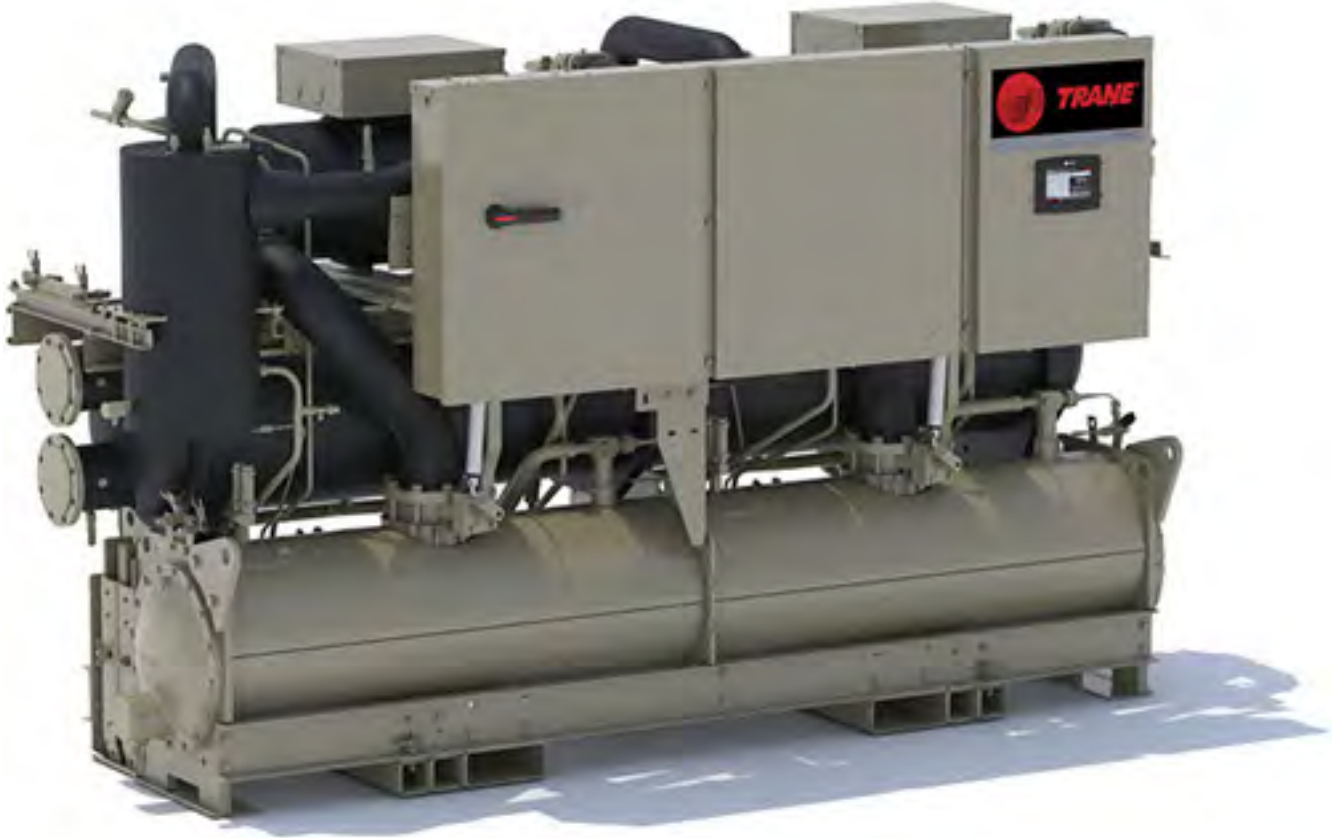

▲ SAFETY WARNING

Only qualified personnel should install and service the equipment. The installation, starting up, and servicing of heating, ventilating, and air-conditioning equipment can be hazardous and requires specific knowledge and training. Improperly installed, adjusted or altered equipment by an unqualified person could result in death or serious injury. When working on the equipment, observe all precautions in the literature and on the tags, stickers, and labels that are attached to the equipment.



Introduction

Read this manual thoroughly before operating or servicing this unit.

Warnings, Cautions, and Notices

Safety advisories appear throughout this manual as required. Your personal safety and the proper operation of this machine depend upon the strict observance of these precautions.

The three types of advisories are defined as follows:



Indicates a potentially hazardous situation which, if not avoided, could result in death or serious injury.



Indicates a potentially hazardous situation which, if not avoided, could result in minor or moderate injury. It could also be used to alert against unsafe practices.



Indicates a situation that could result in equipment or property-damage only accidents.

Important Environmental Concerns

Scientific research has shown that certain man-made chemicals can affect the earth's naturally occurring stratospheric ozone layer when released to the atmosphere. In particular, several of the identified chemicals that may affect the ozone layer are refrigerants that contain Chlorine, Fluorine and Carbon (CFCs) and those containing Hydrogen, Chlorine, Fluorine and Carbon (HCFCs). Not all refrigerants containing these compounds have the same potential impact to the environment. Trane advocates the responsible handling of all refrigerants.

Important Responsible Refrigerant Practices

Trane believes that responsible refrigerant practices are important to the environment, our customers, and the air conditioning industry. All technicians who handle refrigerants must be certified according to local rules. For the USA, the Federal Clean Air Act (Section 608) sets forth the requirements for handling, reclaiming, recovering and recycling of certain refrigerants and the equipment that is used in these service procedures. In addition, some states or municipalities may have additional requirements that must also be adhered to for responsible management of refrigerants. Know the applicable laws and follow them.

⚠ WARNING

Proper Field Wiring and Grounding Required!

Failure to follow code could result in death or serious injury.

All field wiring MUST be performed by qualified personnel. Improperly installed and grounded field wiring poses FIRE and ELECTROCUTION hazards. To avoid these hazards, you MUST follow requirements for field wiring installation and grounding as described in NEC and your local/state/national electrical codes.

⚠ WARNING**Personal Protective Equipment (PPE) Required!**

Failure to wear proper PPE for the job being undertaken could result in death or serious injury.

Technicians, in order to protect themselves from potential electrical, mechanical, and chemical hazards, **MUST** follow precautions in this manual and on the tags, stickers, and labels, as well as the instructions below:

- Before installing/servicing this unit, technicians **MUST** put on all PPE required for the work being undertaken (Examples; cut resistant gloves/sleeves, butyl gloves, safety glasses, hard hat/bump cap, fall protection, electrical PPE and arc flash clothing). **ALWAYS** refer to appropriate Safety Data Sheets (SDS) and OSHA guidelines for proper PPE.
- When working with or around hazardous chemicals, **ALWAYS** refer to the appropriate SDS and OSHA/GHS (Global Harmonized System of Classification and Labelling of Chemicals) guidelines for information on allowable personal exposure levels, proper respiratory protection and handling instructions.
- If there is a risk of energized electrical contact, arc, or flash, technicians **MUST** put on all PPE in accordance with OSHA, NFPA 70E, or other country-specific requirements for arc flash protection, **PRIOR** to servicing the unit. **NEVER PERFORM ANY SWITCHING, DISCONNECTING, OR VOLTAGE TESTING WITHOUT PROPER ELECTRICAL PPE AND ARC FLASH CLOTHING. ENSURE ELECTRICAL METERS AND EQUIPMENT ARE PROPERLY RATED FOR INTENDED VOLTAGE.**

⚠ WARNING**Follow EHS Policies!**

Failure to follow instructions below could result in death or serious injury.

- All Trane personnel must follow the company's Environmental, Health and Safety (EHS) policies when performing work such as hot work, electrical, fall protection, lockout/tagout, refrigerant handling, etc. Where local regulations are more stringent than these policies, those regulations supersede these policies.
- Non-Trane personnel should always follow local regulations.

⚠ WARNING**Cancer and Reproductive Harm!**

This product can expose you to chemicals including lead and bisphenol A (BPA), which are known to the State of California to cause cancer and birth defects or other reproductive harm. For more information go to www.P65Warnings.ca.gov.

⚠ WARNING**Heavy Objects!**

Failure to follow instructions below or properly lift unit could result in unit dropping and possibly crushing operator/ technician which could result in death or serious injury, and equipment or property-only damage.

- Equipment is top heavy. Use caution when lifting/ moving equipment to prevent unit from tipping.
- Ensure that all the lifting equipment used is properly rated for the weight of the unit being lifted. Each of the cables (chains or slings), hooks, and shackles used to lift the unit must be capable of supporting the entire weight of the unit. Lifting cables (chains or slings) may not be of the same length. Adjust as necessary for even unit lift.
- The high center of gravity on this unit requires the use of an anti-rolling cable (chain or sling). To prevent unit from rolling, attach cable (chain or sling) with no tension and minimal slack around compressor suction pipe as shown.
- Do not use forklift to move or lift unit unless unit has lifting base with base rail forklifting option.



Introduction

⚠ WARNING

Refrigerant Vapor Hazard!

Failure to follow instructions below could result in death or serious injury.

Refrigerant or other gases could displace available oxygen, causing possible asphyxiation or other serious health risks. Some gases may be flammable and/or explosive.

- Use only genuine Trane replacement parts when performing maintenance procedures.
- Do not repair or alter the device beyond the scope of these maintenance instructions.
- Repairs must be performed by authorized Trane service personnel ONLY.

⚠ WARNING

System is Pressurized!

Failure to follow instructions below could result in death, serious injury, or equipment damage.

Only qualified personnel should operate valves and open system.

Copyright

This document and the information in it are the property of Trane, and may not be used or reproduced in whole or in part without written permission. Trane reserves the right to revise this publication at any time, and to make changes to its content without obligation to notify any person of such revision or change.

Trademarks

All trademarks referenced in this document are the trademarks of their respective owners.



Table of Contents

Icon Key.....	8
Disassembling the Unit to Fit Through a 36 × 80-inch Door.....	10
1 – Disassemble the Panel Door Screws.....	11
2 – Swing the Panel Doors Open.....	11
3 – Disassemble Circuit 2 Thermosyphon Valve Wiring.....	12
4 – Disassemble Circuit 2 Compressor Heater Wiring.....	13
5 – Disassemble Circuit 1 Thermosyphon Valve Wiring.....	14
6 – Disassemble Circuit 1 Compressor Heater Wiring.....	15
7 – Disassemble Circuit 2 Separator Heater Wiring.....	16
8 – Disassemble Circuit 1 Separator Heater Wiring.....	17
9 – Disassemble Thermal Safety Switch Wiring.....	18
10 – Disassemble Bus Wiring.....	19
11 – Disassemble Compressor Wiring.....	20
12 – Disassemble Back Panel Conduit.....	21
13 – Secure the Disassembled Loose Wire.....	22
14 – Panel Lift Support.....	22
15 – Disassemble Rear Panel Mounting Bolt.....	23
16 – Disassemble Panel Front Mount Bolts.....	23
17 – Lift the Panel from the Unit.....	24
18 – Place the Panel on a Flat Surface.....	24
19 – Disassemble Evaporator Lift Supports.....	25
20 – Disassemble Condenser Lift Support.....	25
21 – Disassemble Condenser Lift Support.....	26
Parts Removed in this Procedure.....	26
Updated Dimensions after Parts Removal.....	27
Full Disassembly – Removing the Compressor and Oil Separator.....	28
1 – Drain Oil from Compressors.....	28
2 – Disconnect Wires from Oil Separator.....	29
3 – Lift-Strapping the Oil Separator.....	30
4 – Disassemble Oil Separator Assembly.....	31
5 – Disassemble Oil Separator Drain Line.....	32
6 – Disassemble Oil Separator Discharge Line.....	33
Option 1 – De-braze the Pipe.....	33
Option 2 – Cut the Pipe.....	33
Assembly Only.....	34
7 – Remove Oil Separator Assembly.....	34

8 – Disassemble Compressor Wire Connectors	35
9 – Disassemble Compressor Suction Line	35
10 – Disassemble Suction Line Assembly	36
11 – Remove Suction Line Assembly	36
12 – Disassemble Oil Supply Line Mounting	37
13 – Disassemble Compressor Drain Line	38
14 – Disassemble Compressor Transducer Assembly	39
15 – Disassemble Compressor Oil Supply Line	39
16 – Compressor Lift Support	40
17 – Disassemble Compressor Mounting Hardware	40
18 – Remove Compressor Assembly	41
Parts Removed in this Procedure	41
Updated Dimensions after Parts Removal	42
Removing the Condenser	43
1 – Disassemble Condenser Wire Connectors	43
2 – Disassemble Flow Proving Wiring	44
3 – Condenser Lift Support	44
4 – Disassemble Base Rail Mounting Hardware	45
5 – Remove Base Rail Assembly	45
6 – Disassemble Condenser Piping	46
7 – Disassemble Condenser Piping and EXV	47
8 – Remove Liquid Line Assembly	48
9 – Lift Support Condenser Assembly	48
10 – Disassemble Condenser Mounting Hardware	49
11 – Disassemble Condenser Mounting Hardware	50
12 – Remove Condenser Assembly	50
13 – Disassemble Evaporator Piping	51
14 – Disassemble Thermosyphon Assembly	52
15 – Remove Circuit 1 Thermosyphon Assembly	53
16 – Remove Circuit 2 Thermosyphon Assembly	54
17 – Disassemble Control Panel Mounting Support	54
Parts Removed in this Procedure	55
Updated Dimensions after Parts Removal	55

Icon Key

Table 1. Icon descriptions











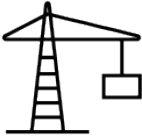

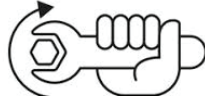









Icon	Description	Icon	Description
	Lift with proper equipment		Lifting or equivalent support
	Screwdriver-tighten		Wrench-tighten
	Rotated part		Rotated image
	Braze		Replace gasket, O-ring, or washer
	Nitrogen purge		Shield components
	Apply thread-locking compound		Hidden components
	Push disconnect		Wiggle disconnect
	Pinch disconnect		Slotted screwdriver
	Phillips screwdriver		Allen key

Table 1. Icon descriptions (continued)

Icon	Description	Icon	Description
	Behind components		Motion
	Cut pipe		Cover piping/cover opening
	Apply oil		

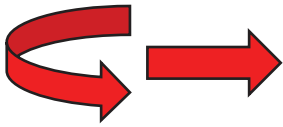

Disassembling the Unit to Fit Through a 36 × 80-inch Door

⚠ WARNING

Hazardous Voltage!

Failure to disconnect power before servicing could result in death or serious injury. Disconnect all electric power, including remote disconnects before servicing. Follow proper lockout/ tagout procedures to ensure the power cannot be inadvertently energized. Verify that no power is present with a voltmeter. To prevent electrical shock, confirm the circuit board cover is in place prior to powering unit.

⚠ WARNING

Proper Field Wiring and Grounding Required!

Failure to follow code could result in death or serious injury. All field wiring **MUST** be performed by qualified personnel. Improperly installed and grounded field wiring poses **FIRE** and **ELECTROCUTION** hazards. To avoid these hazards, you **MUST** follow requirements for field wiring installation and grounding as described in NEC and your local/state/national electrical codes.

Figure 1. Turn the breaker to the Off position



1 – Disassemble the Panel Door Screws

Figure 2. Disassemble panel door screws

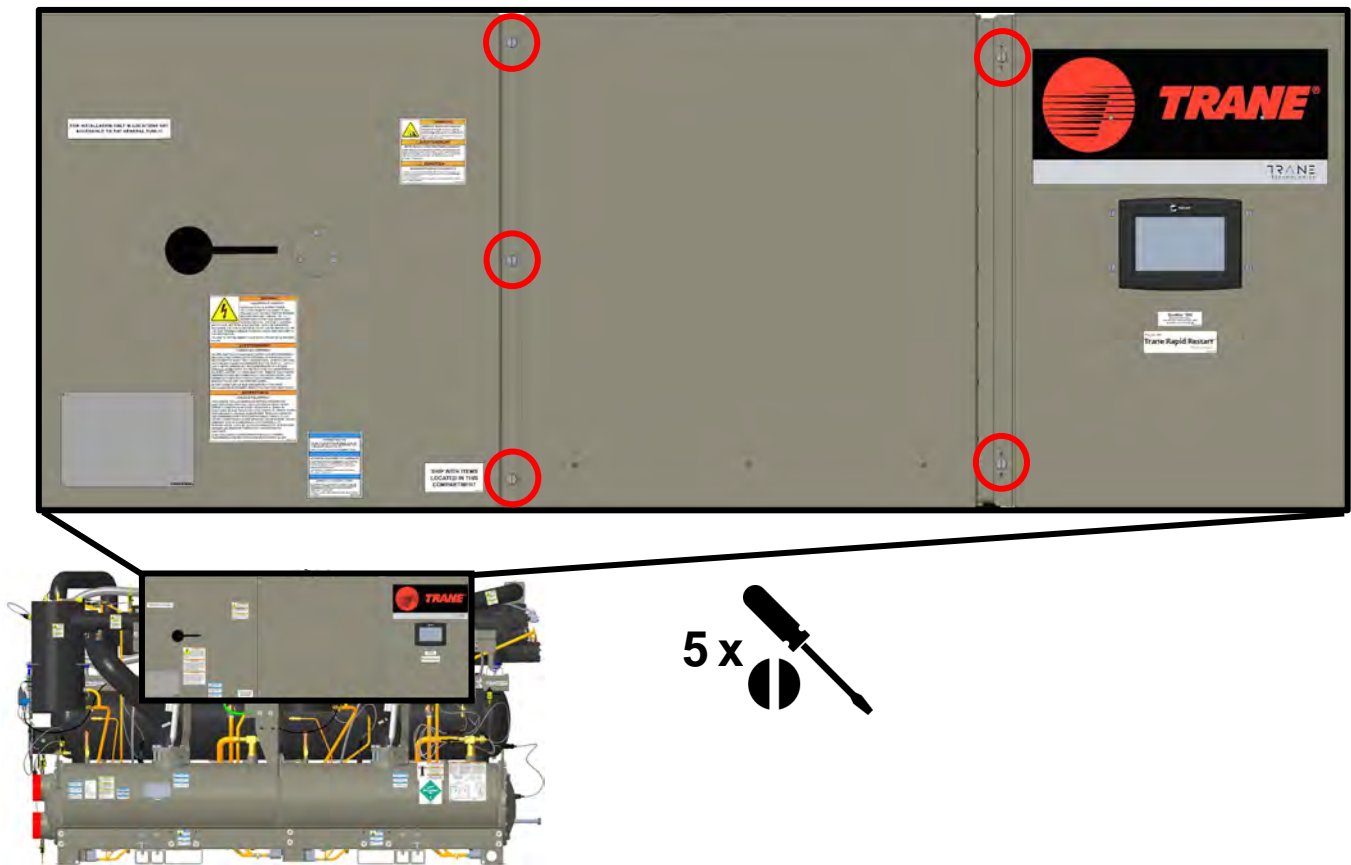

2 – Swing the Panel Doors Open

Figure 3. Swing panel doors open

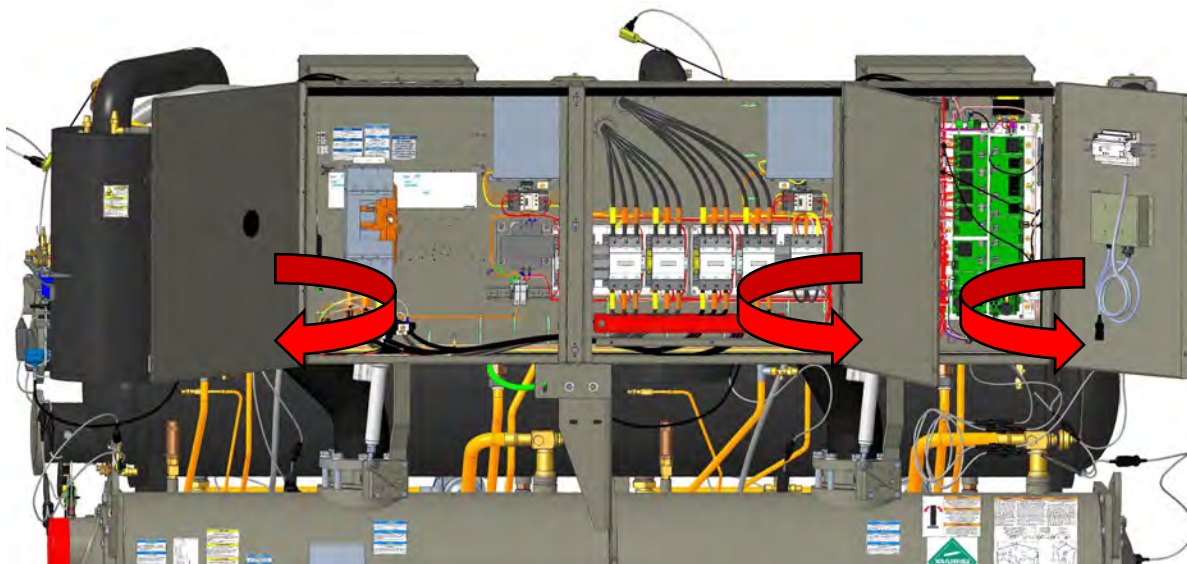

4 – Disassemble Circuit 2 Compressor Heater Wiring

Figure 5. Disassemble circuit 2 compressor heater wiring

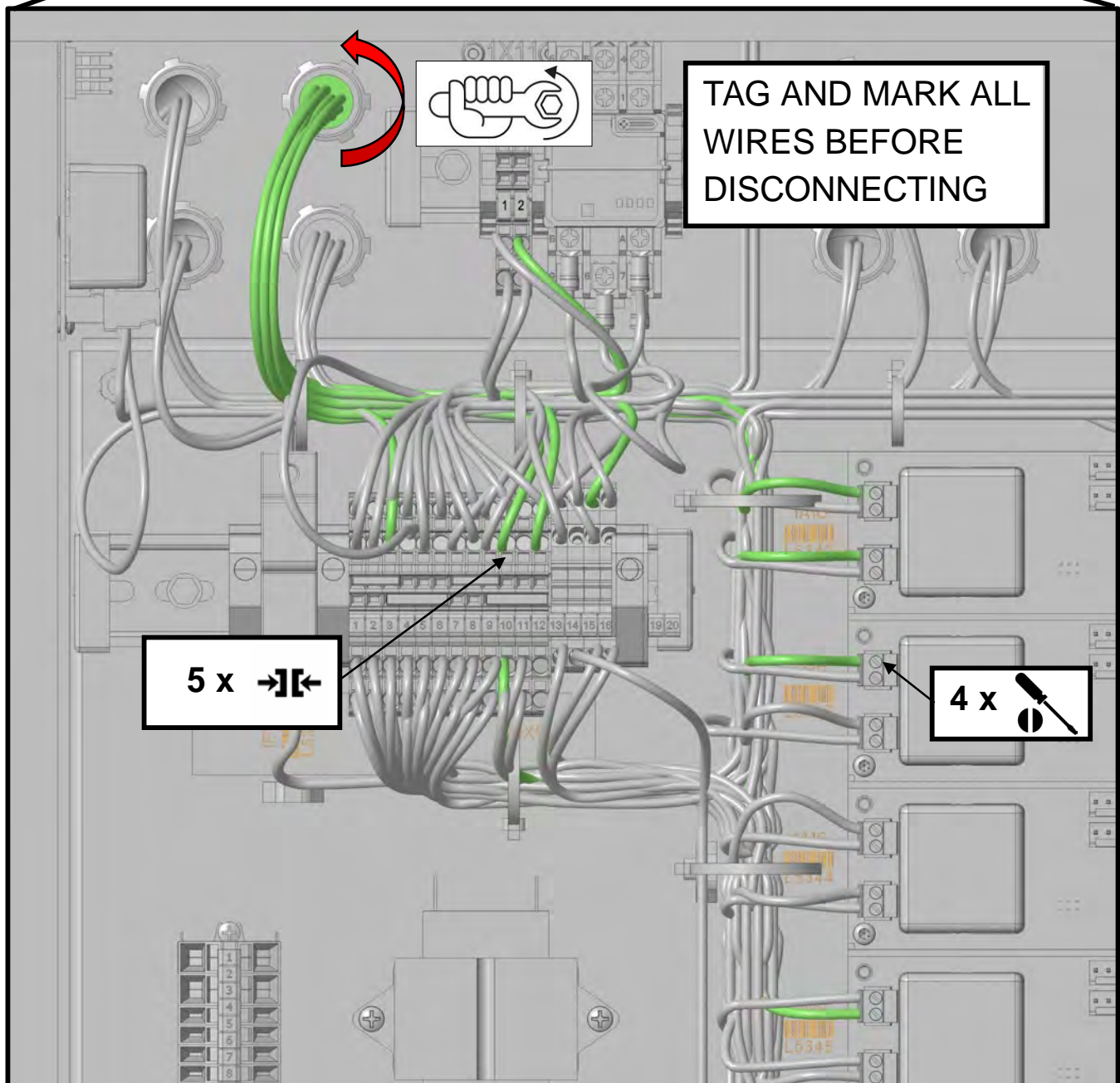
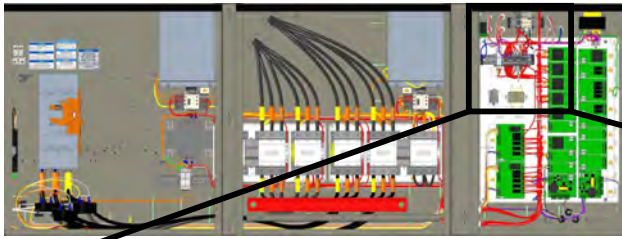

5 – Disassemble Circuit 1 Thermosyphon Valve Wiring

Figure 6. Disassemble circuit 1 thermosyphon valve wiring

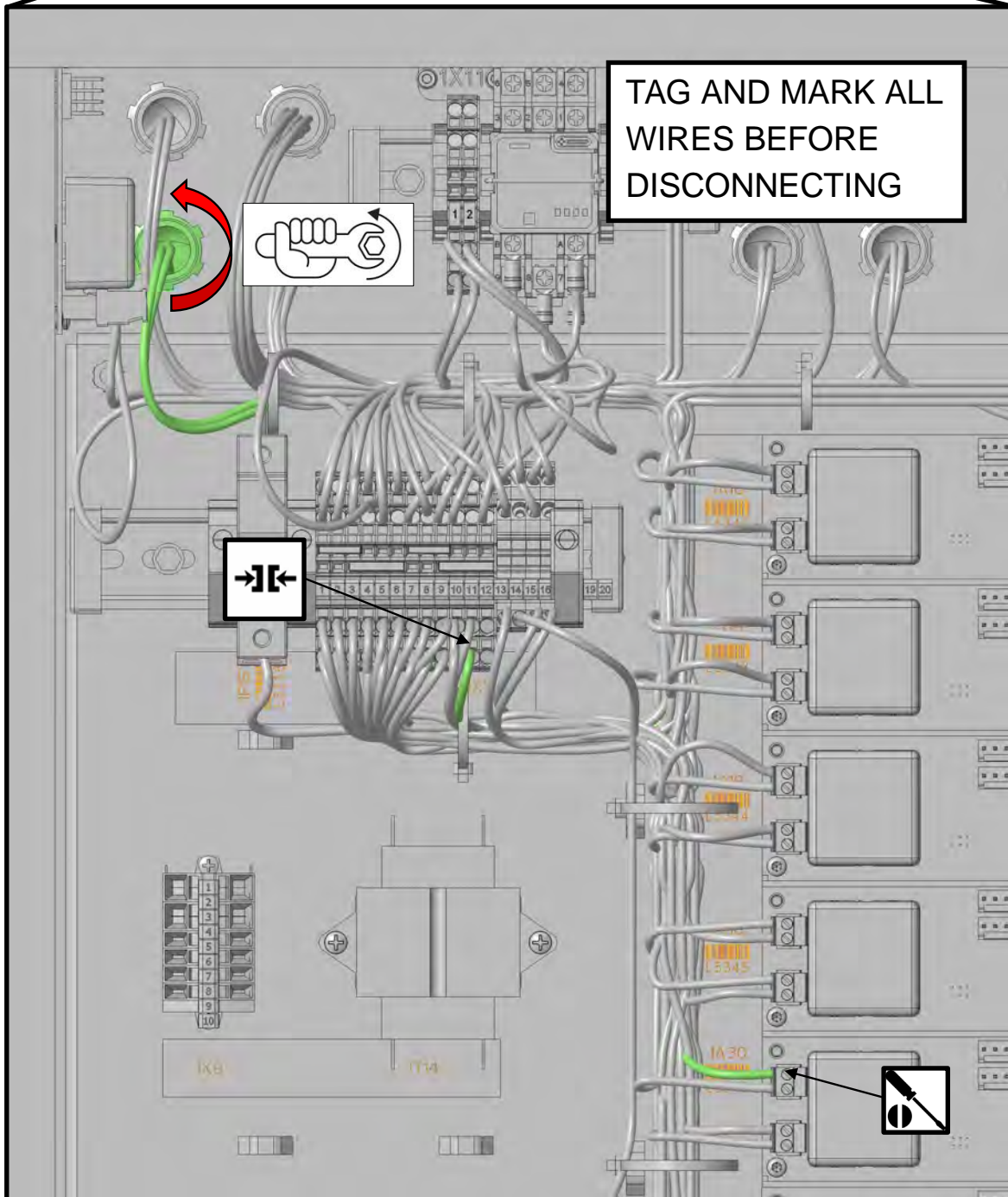
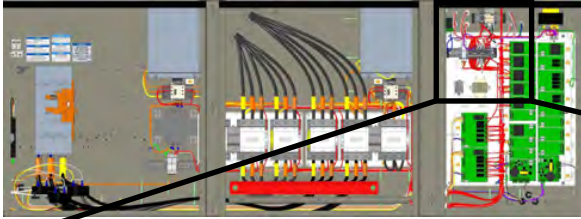

6 – Disassemble Circuit 1 Compressor Heater Wiring

Figure 7. Disassemble circuit 1 compressor heater wiring

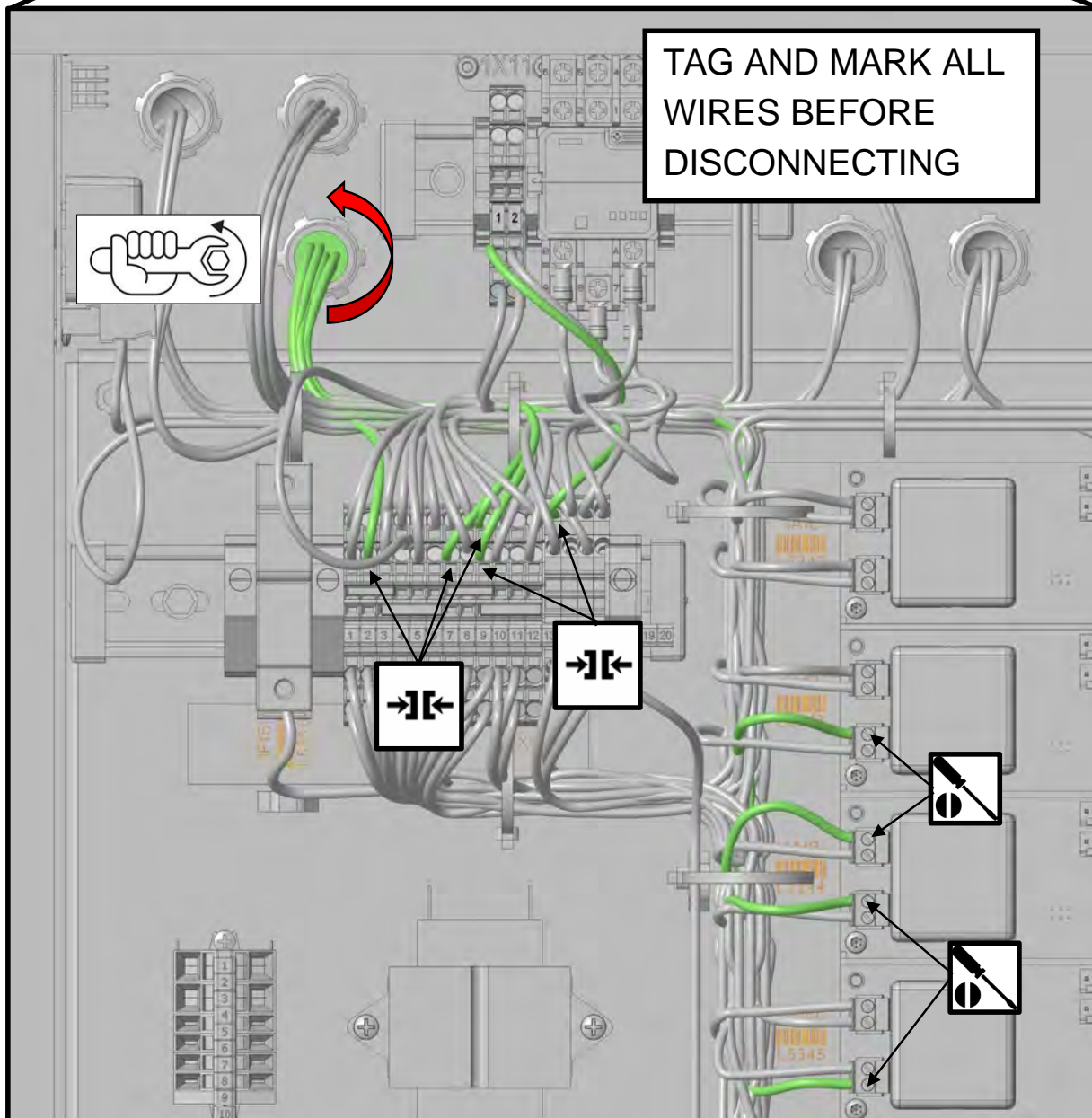
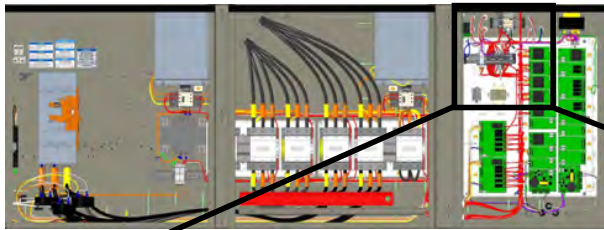

7 – Disassemble Circuit 2 Separator Heater Wiring

Figure 8. Disassemble circuit 2 separator heater wiring

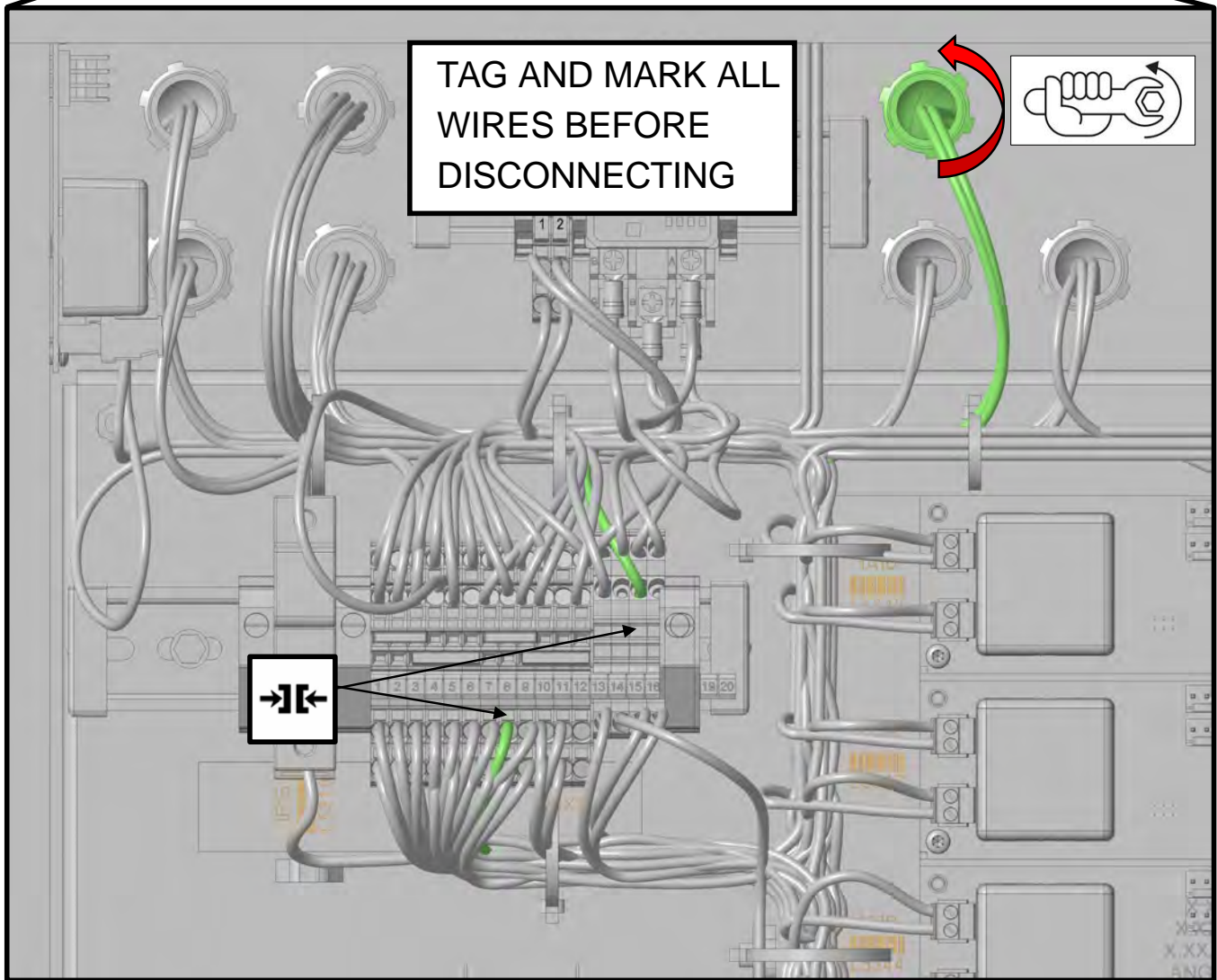
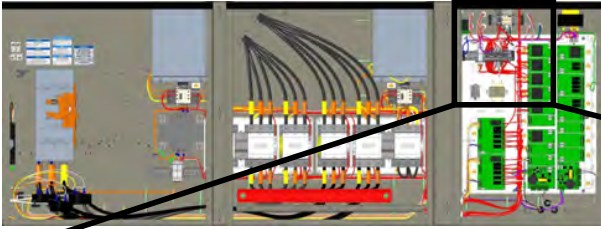

8 – Disassemble Circuit 1 Separator Heater Wiring

Figure 9. Disassemble circuit 1 separator heater wiring

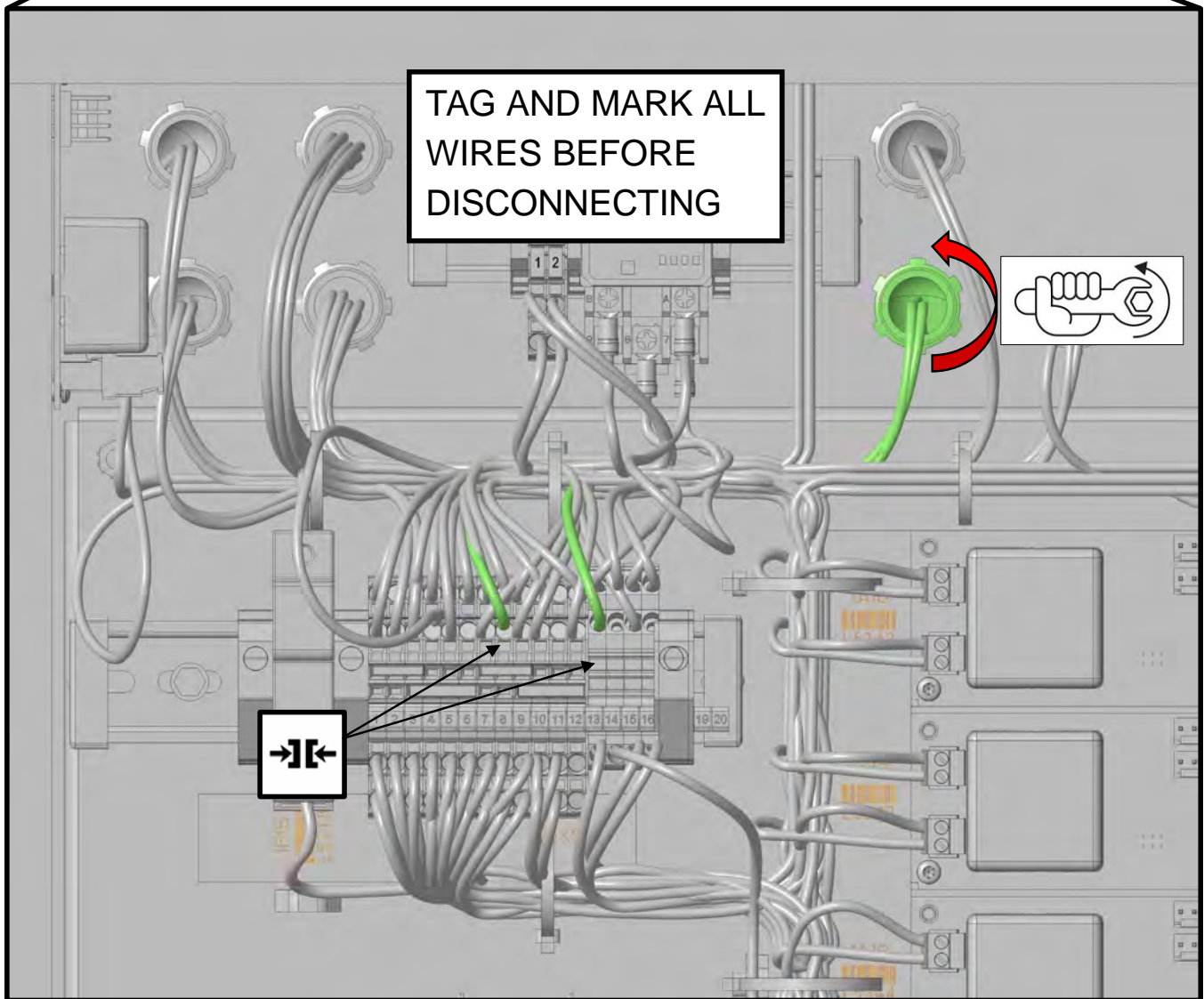
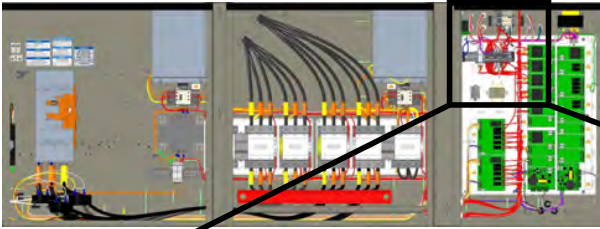

9 – Disassemble Thermal Safety Switch Wiring

Figure 10. Disassemble thermal safety switch wiring

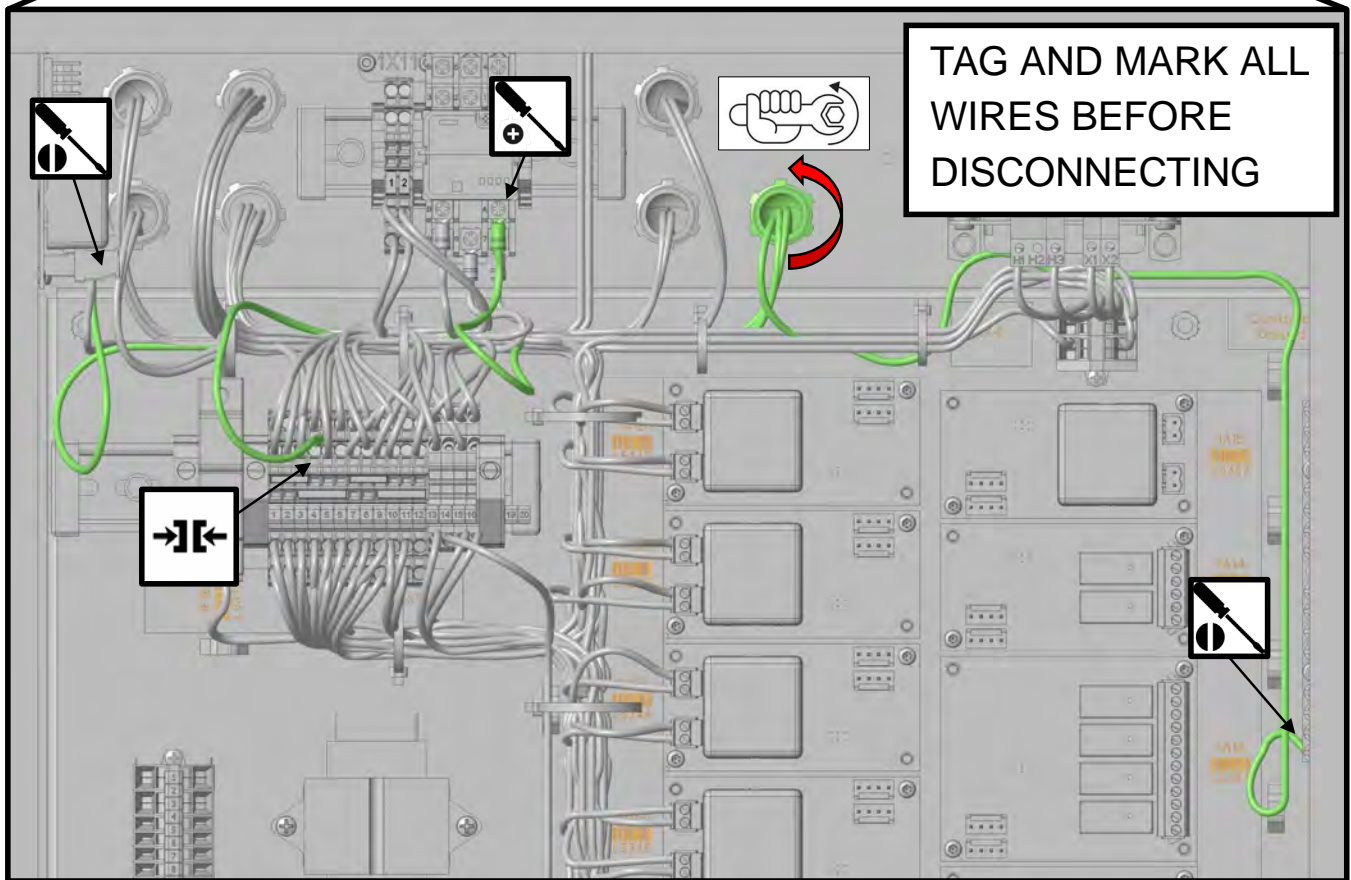
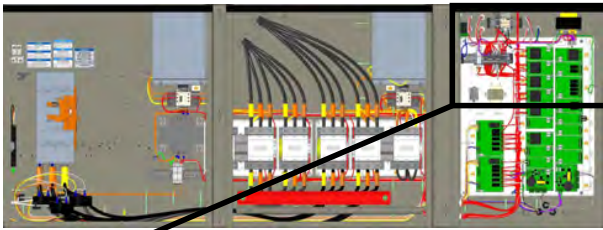

10 – Disassemble Bus Wiring

Figure 11. Disassemble bus wiring

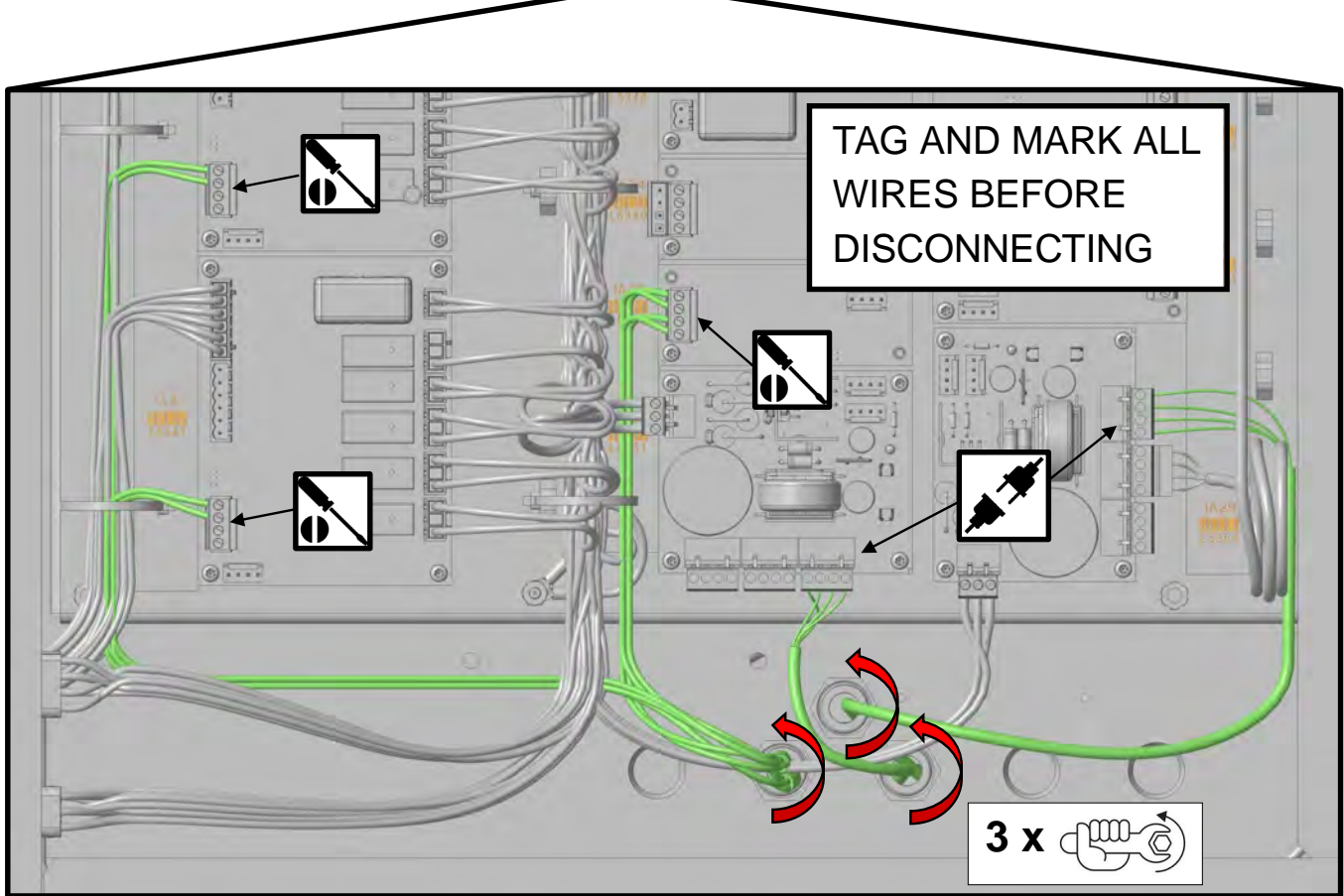
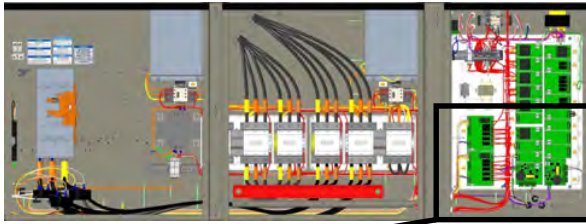

11 – Disassemble Compressor Wiring

Figure 12. Disassemble compressor wiring

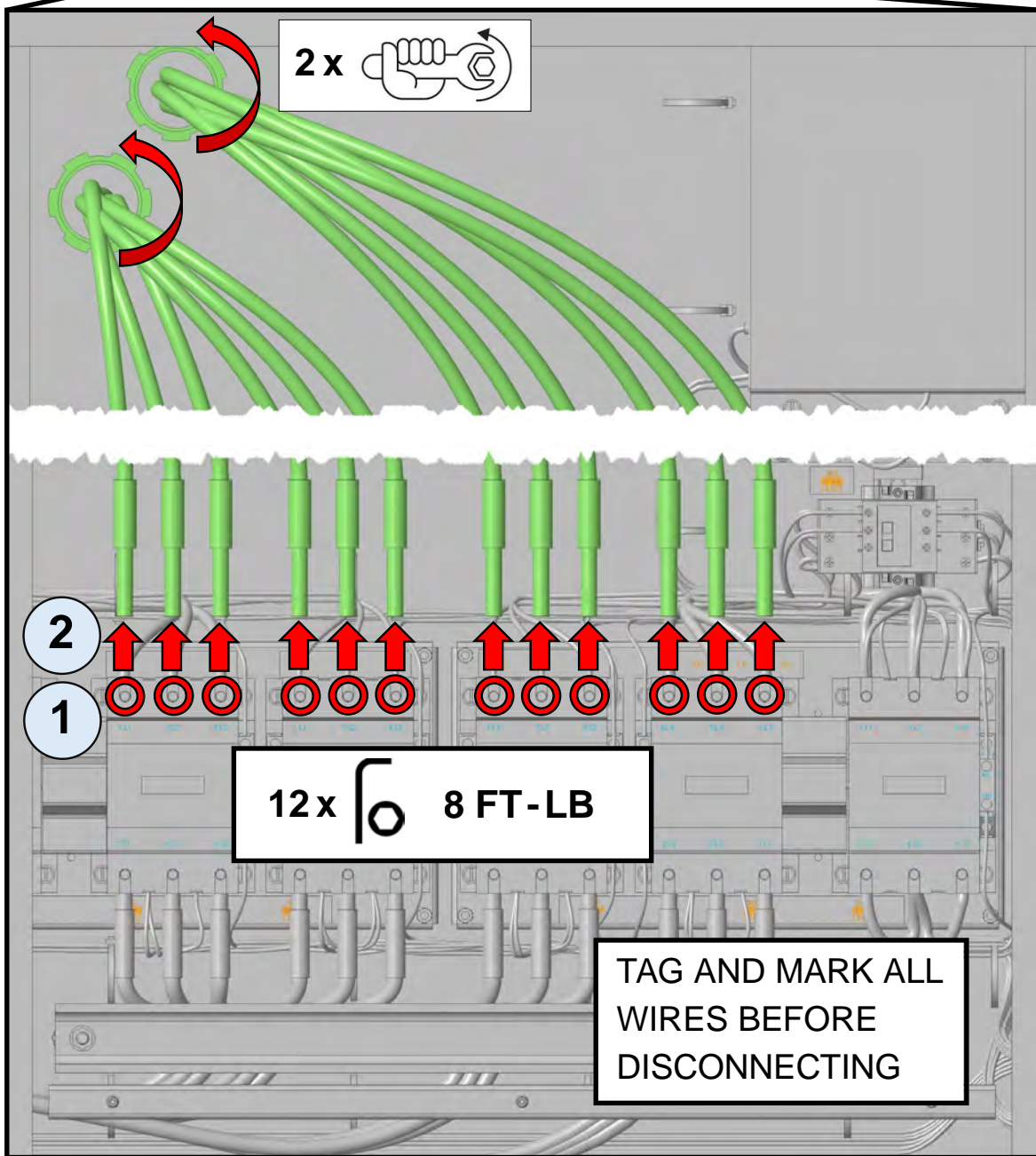
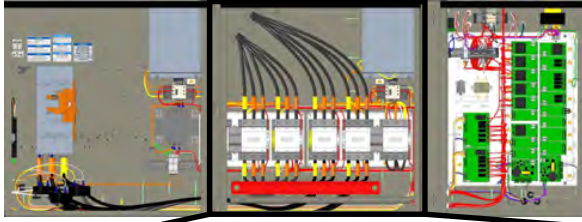

12 – Disassemble Back Panel Conduit

Figure 13. Disassemble back panel conduit

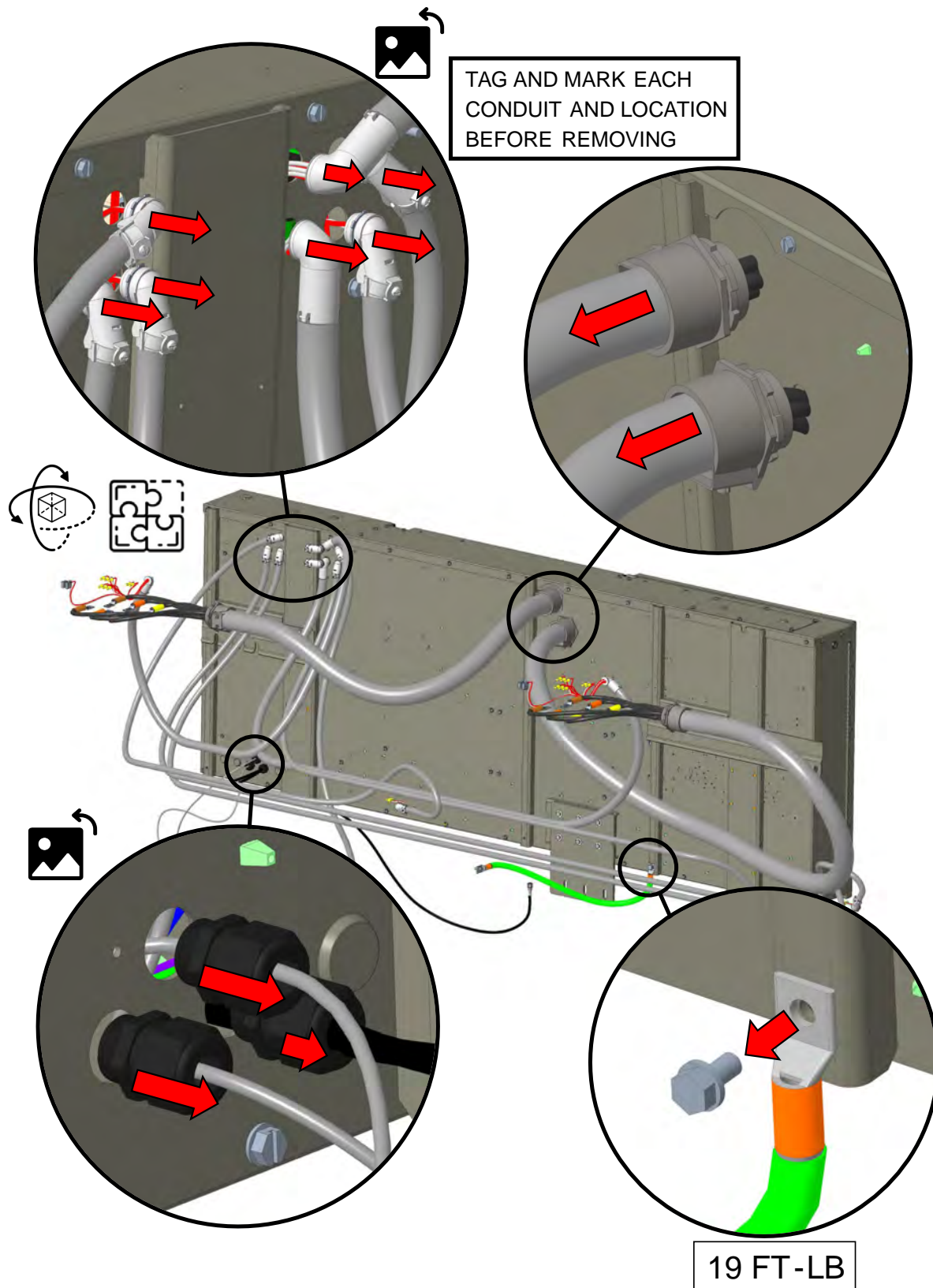

13 – Secure the Disassembled Loose Wire

Figure 14. Disassembled loose wire securement

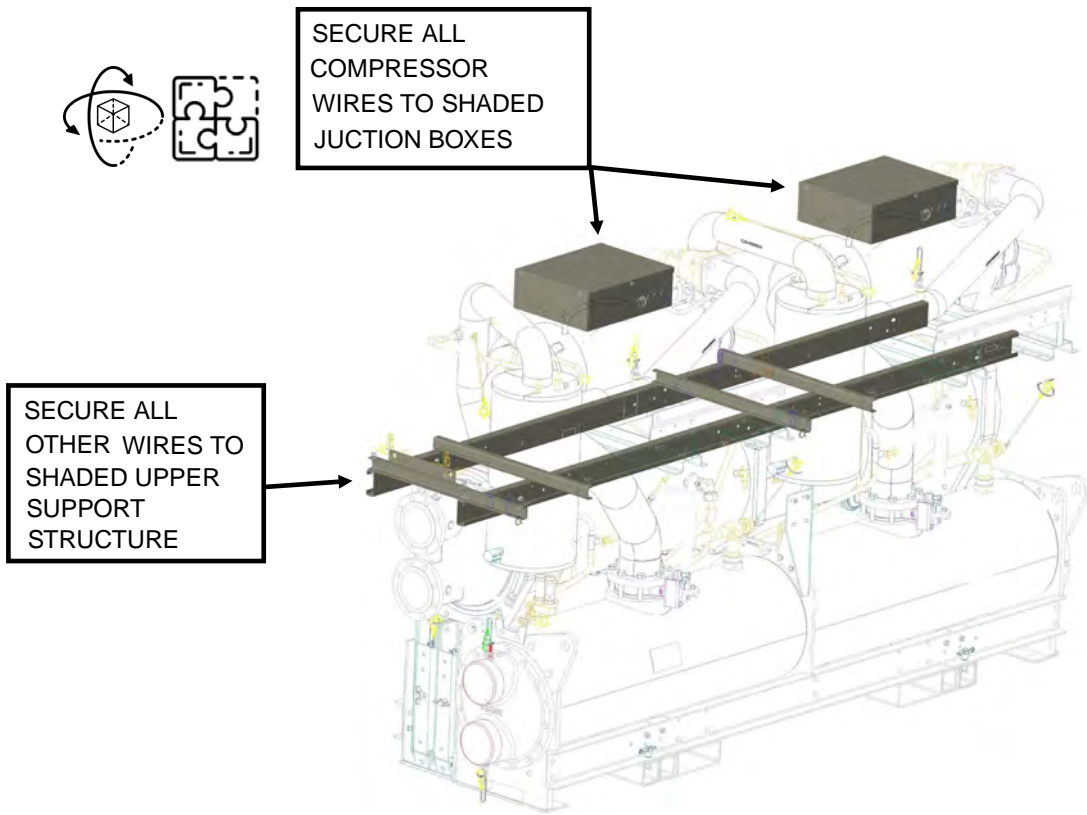

14 – Panel Lift Support

Figure 15. Panel lift support

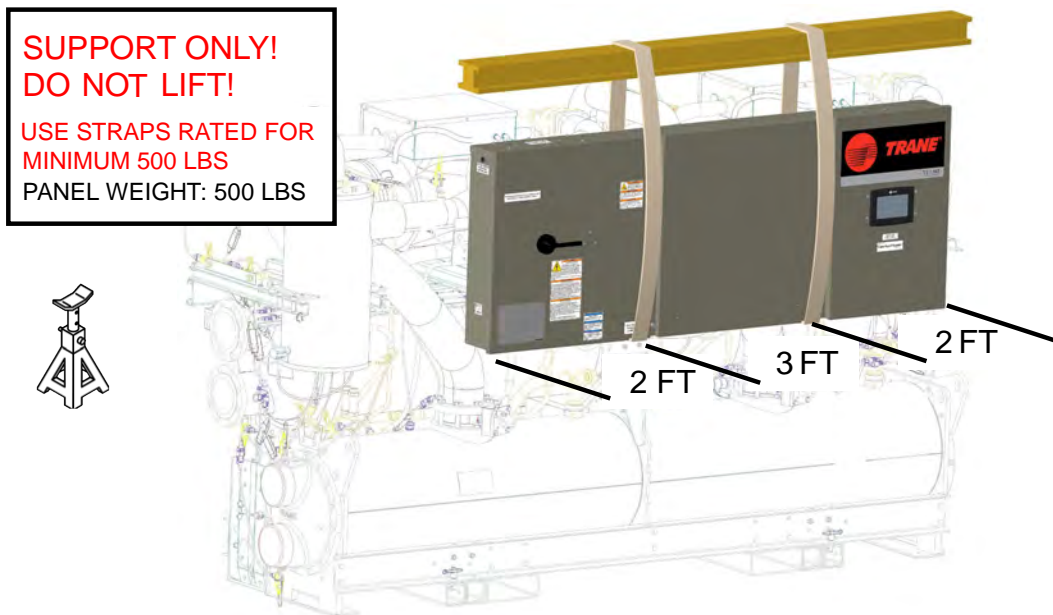

15 – Disassemble Rear Panel Mounting Bolt

Figure 16. Disassemble rear panel mounting bolt

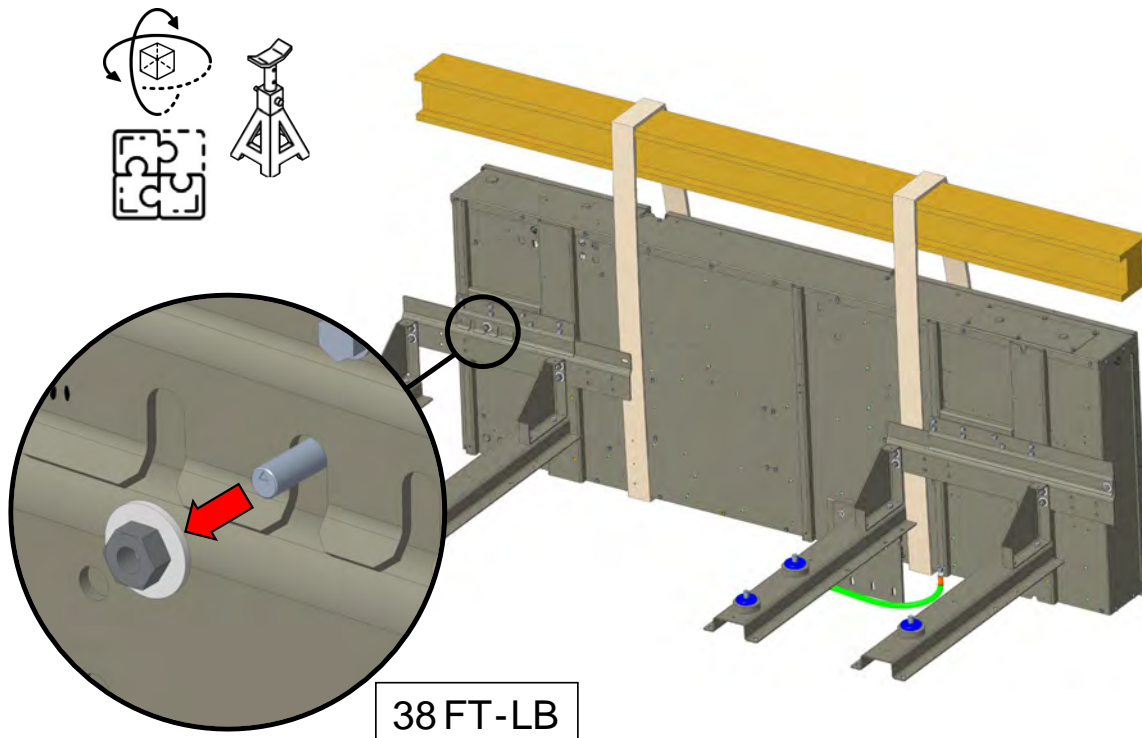

16 – Disassemble Panel Front Mount Bolts

Figure 17. Disassemble panel front mount bolts

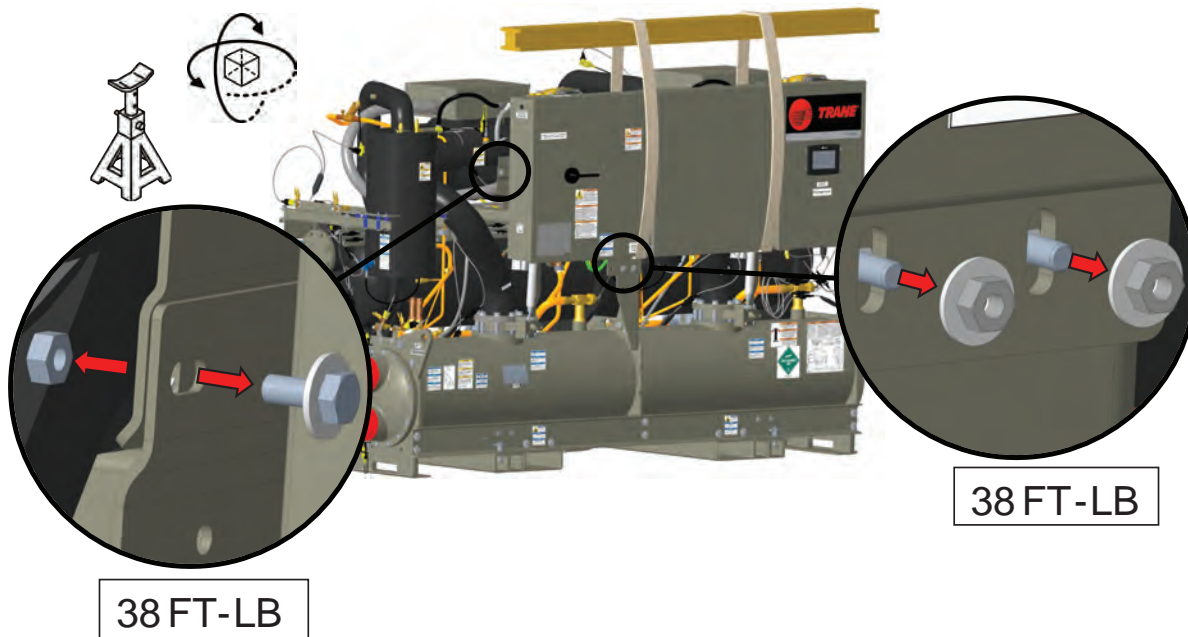



Disassembling the Unit to Fit Through a 36 × 80-inch Door

17 – Lift the Panel from the Unit

Figure 18. Lift the panel from the unit

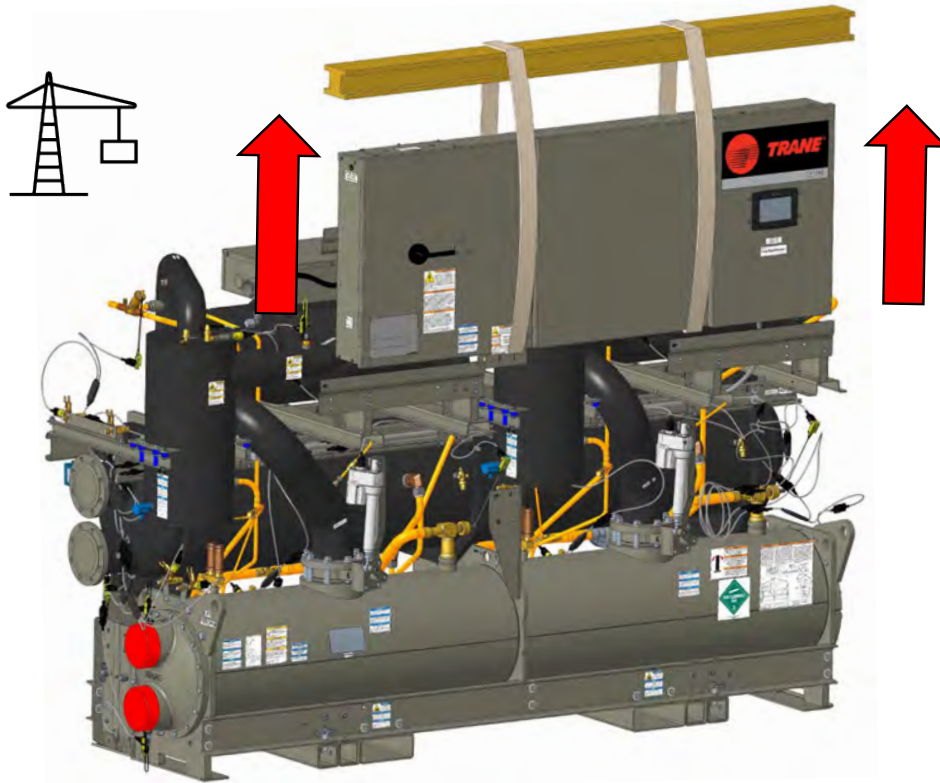

18 – Place the Panel on a Flat Surface

Figure 19. Place the panel on a flat surface



LAY ELECTRICAL PANEL
ON BACK SIDE. SUPPORT
WITH WOOD OR OTHER
SUITABLE MATERIAL.

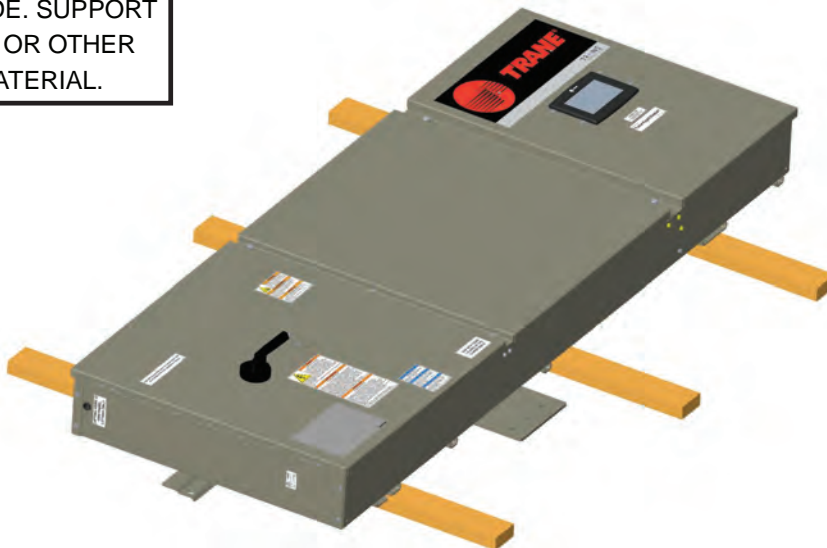

19 – Disassemble Evaporator Lift Supports

Figure 20. Disassemble evaporator lift supports

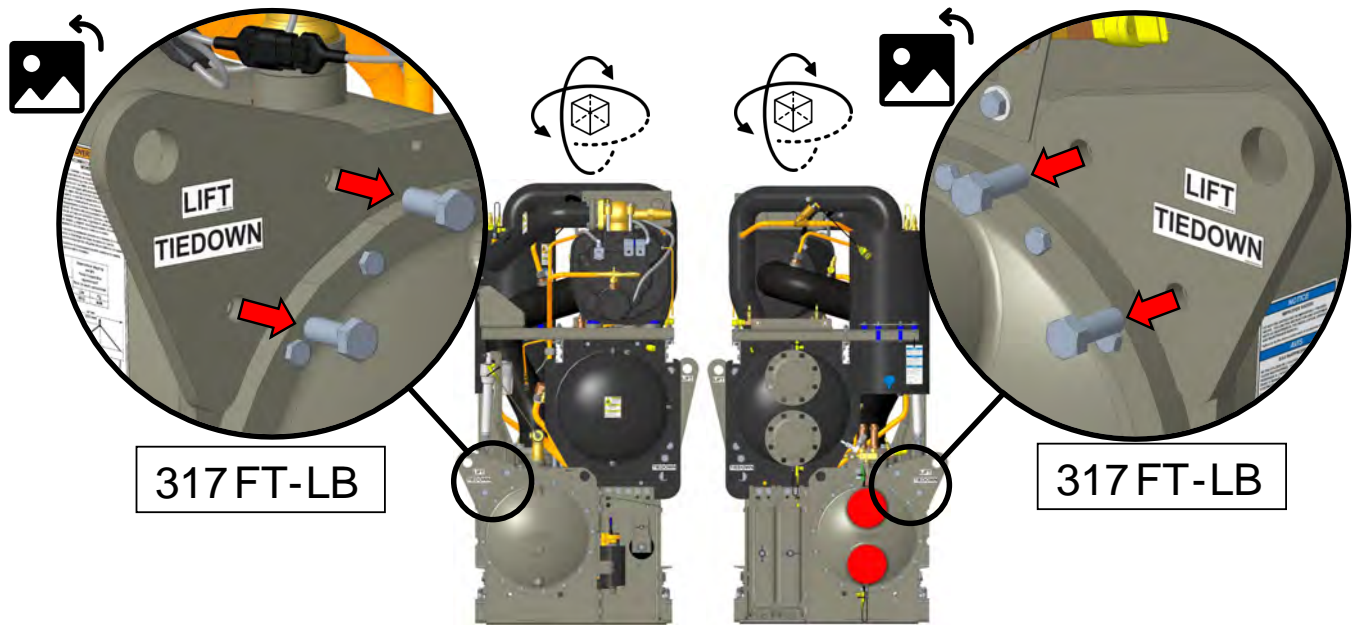

20 – Disassemble Condenser Lift Support

Figure 21. Disassemble condenser lift support

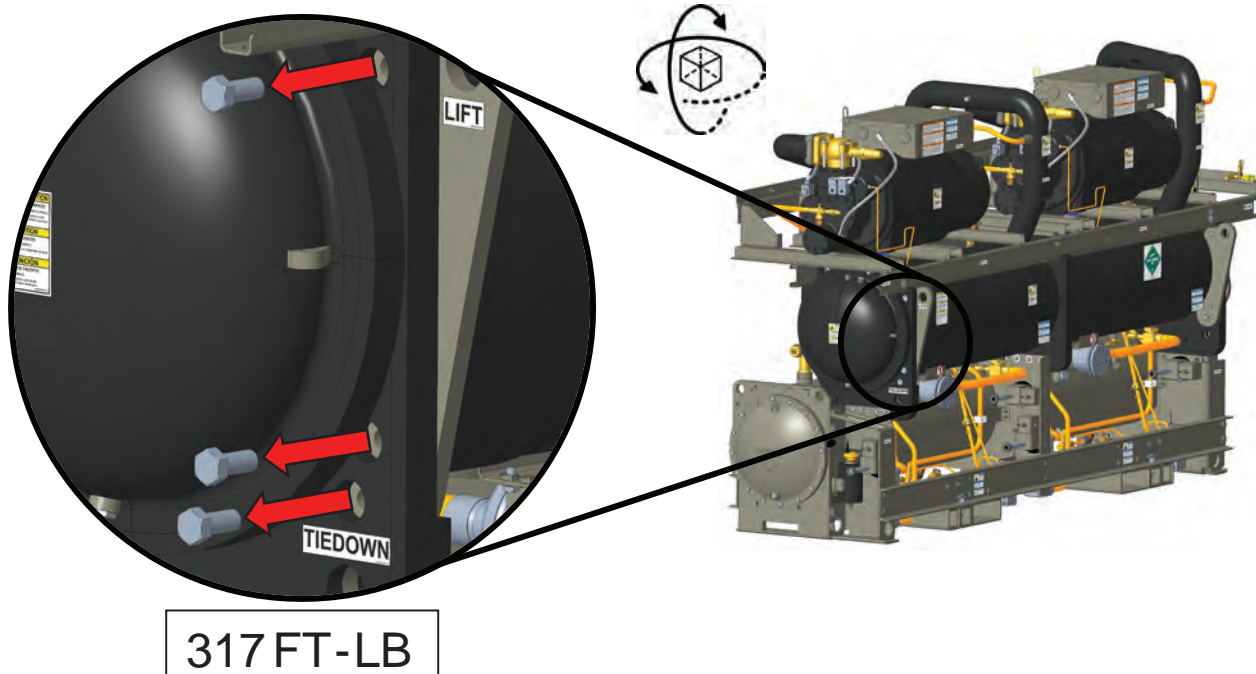



Disassembling the Unit to Fit Through a 36 × 80-inch Door

21 – Disassemble Condenser Lift Support

Figure 22. Disassemble condenser lift support

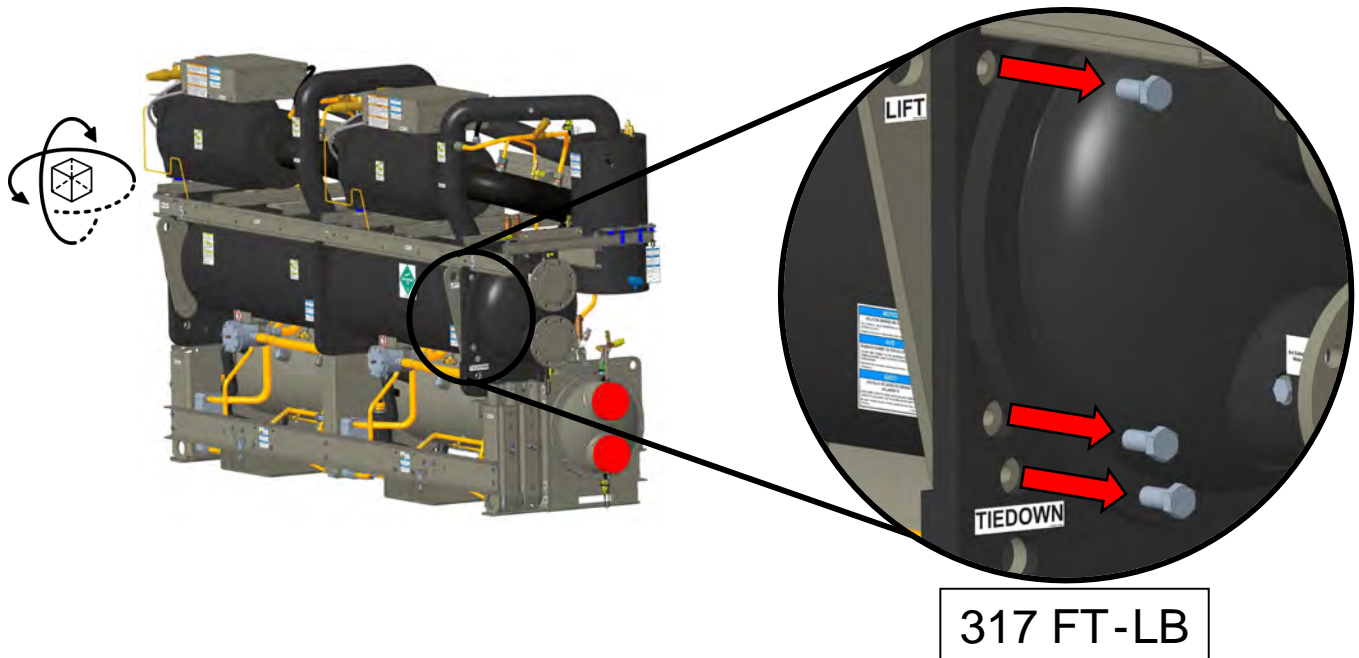

Parts Removed in this Procedure

Figure 23. Parts removed



Updated Dimensions after Parts Removal

Figure 24. Updated dimensions

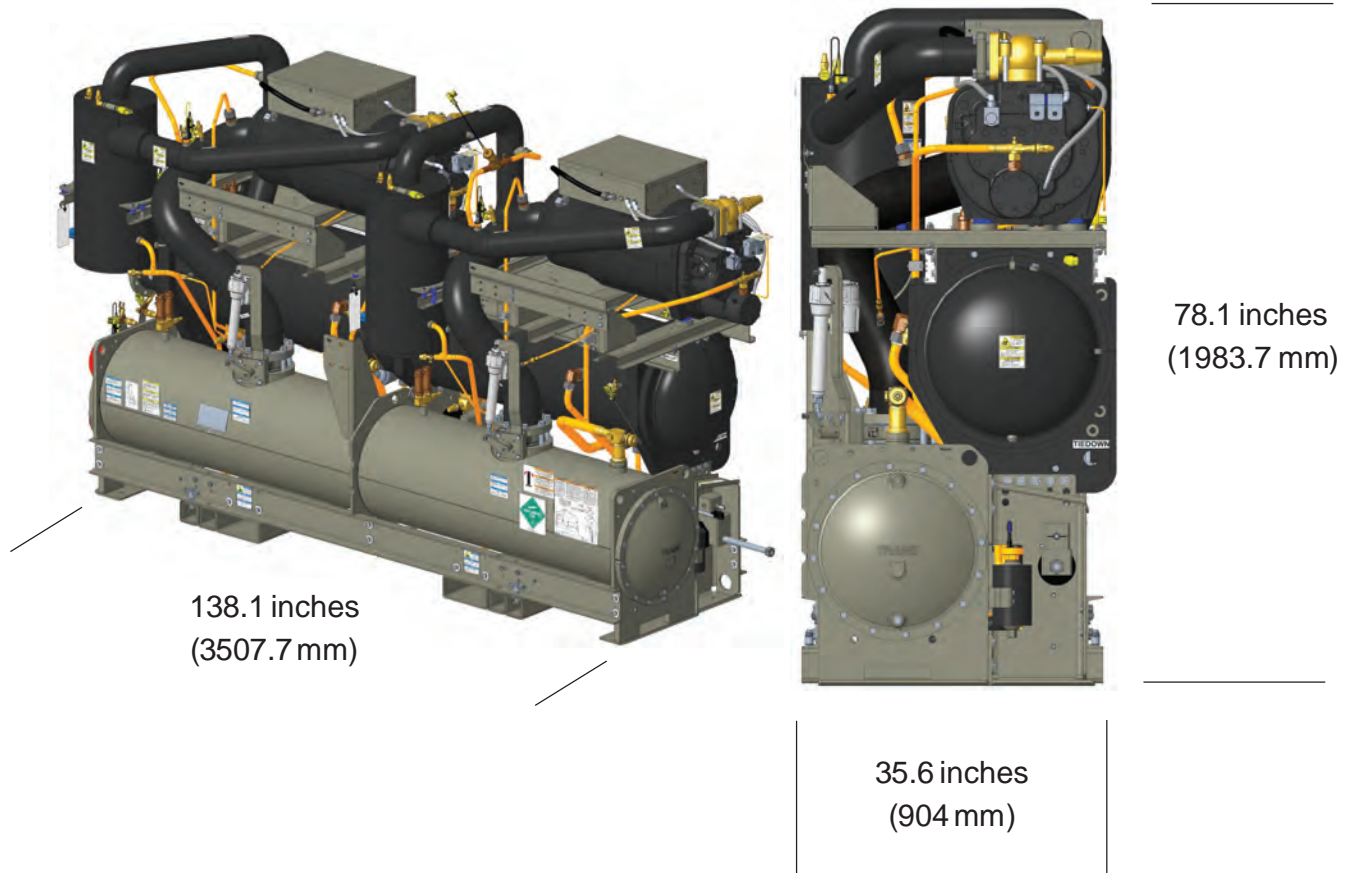

Full Disassembly – Removing the Compressor and Oil Separator

Continue after completing “Disassembling the Unit to Fit Through a 36 × 80-inch Door,” p. 10.

Repeat the steps below for both Circuit 1 and Circuit 2 to remove the second compressor.

Figure 25. Split view – circuit 1 and circuit 2

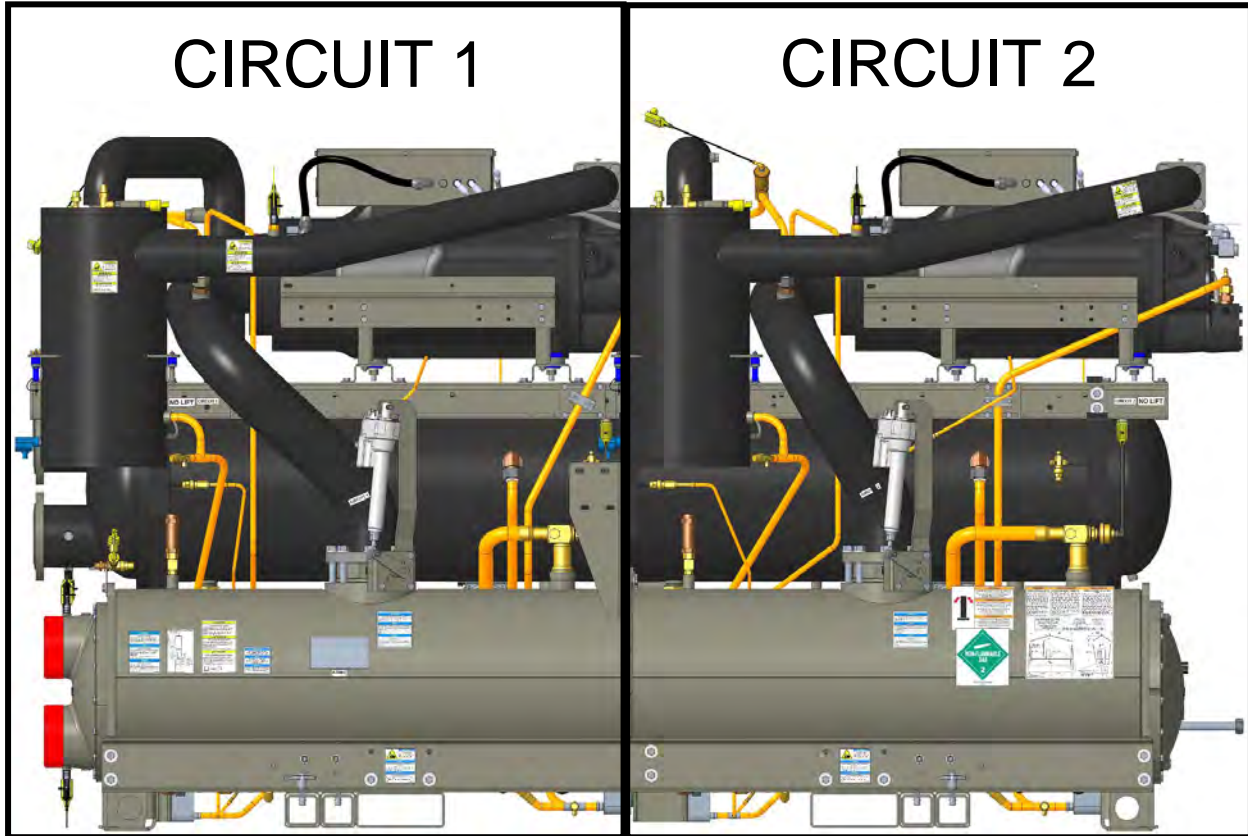

1 – Drain Oil from Compressors

Recover the refrigerant from the unit and drain all the oil from the compressors.

2 – Disconnect Wires from Oil Separator

Figure 26. Disconnect wires from oil separator

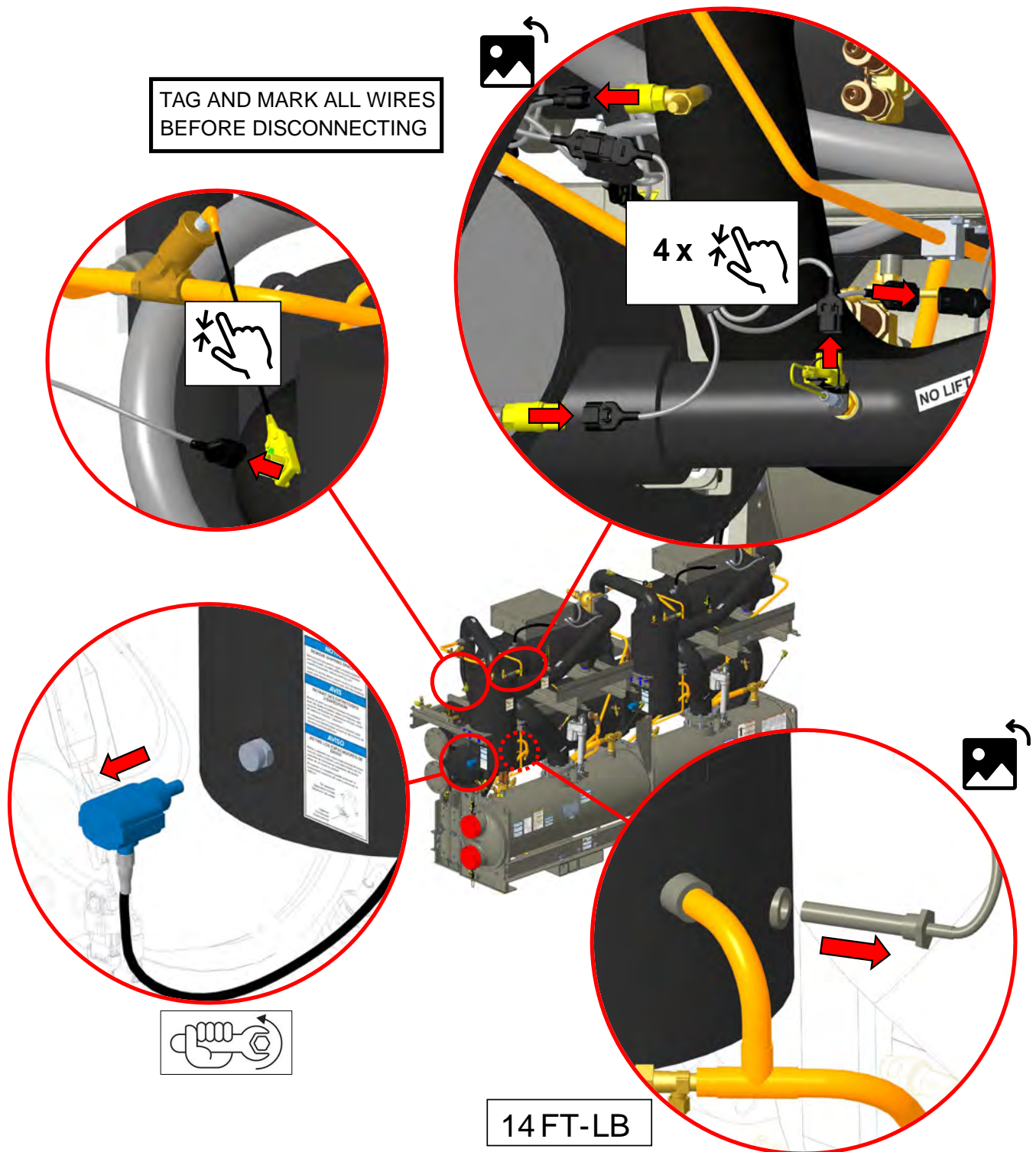

3 – Lift-Strapping the Oil Separator

Figure 27. Lift strapping the oil separator



**SUPPORT ONLY!
DO NOT LIFT!**

USE STRAPS RATED FOR
MINIMUM 300 LB
OIL SEPARATOR WEIGHT: 300 LB

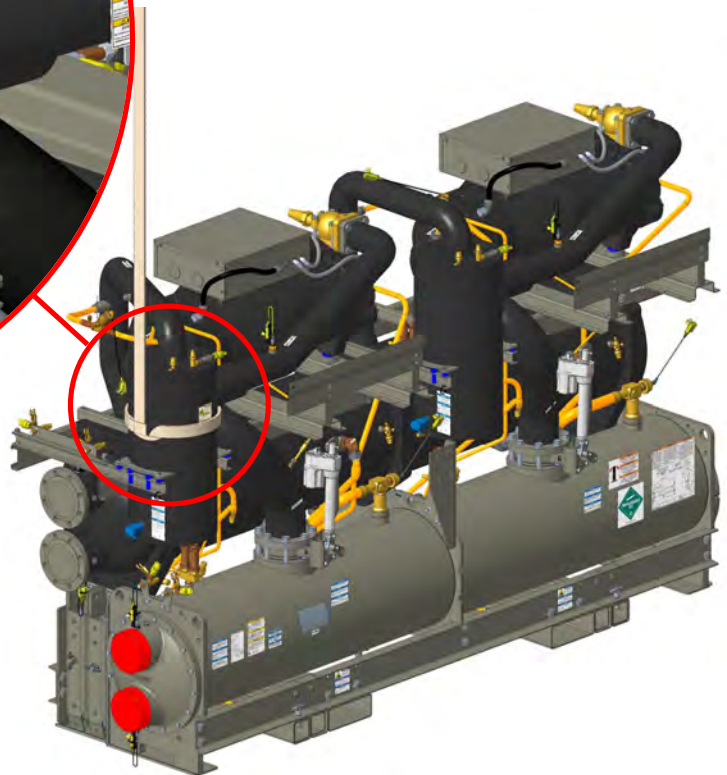
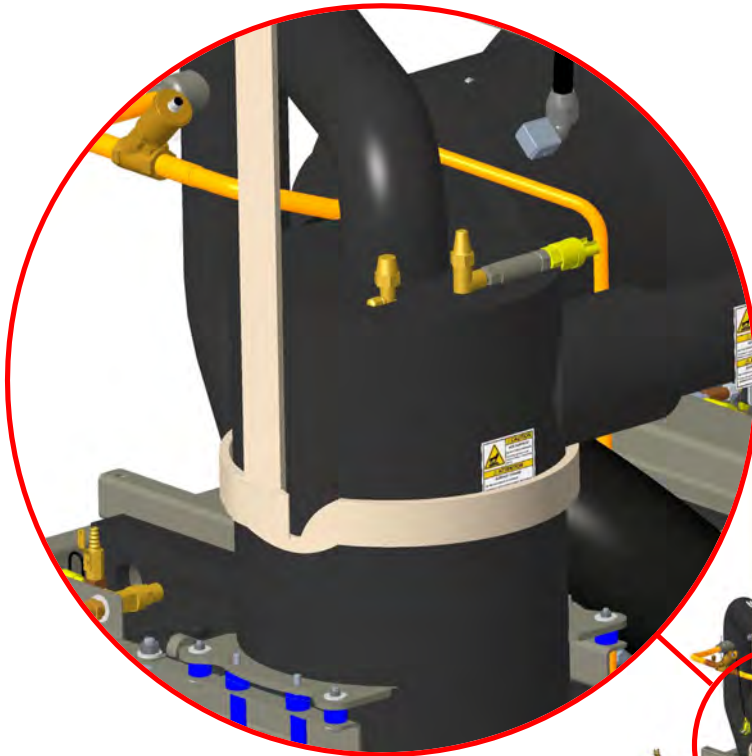

4 – Disassemble Oil Separator Assembly

Figure 28. Disassemble oil separator assembly

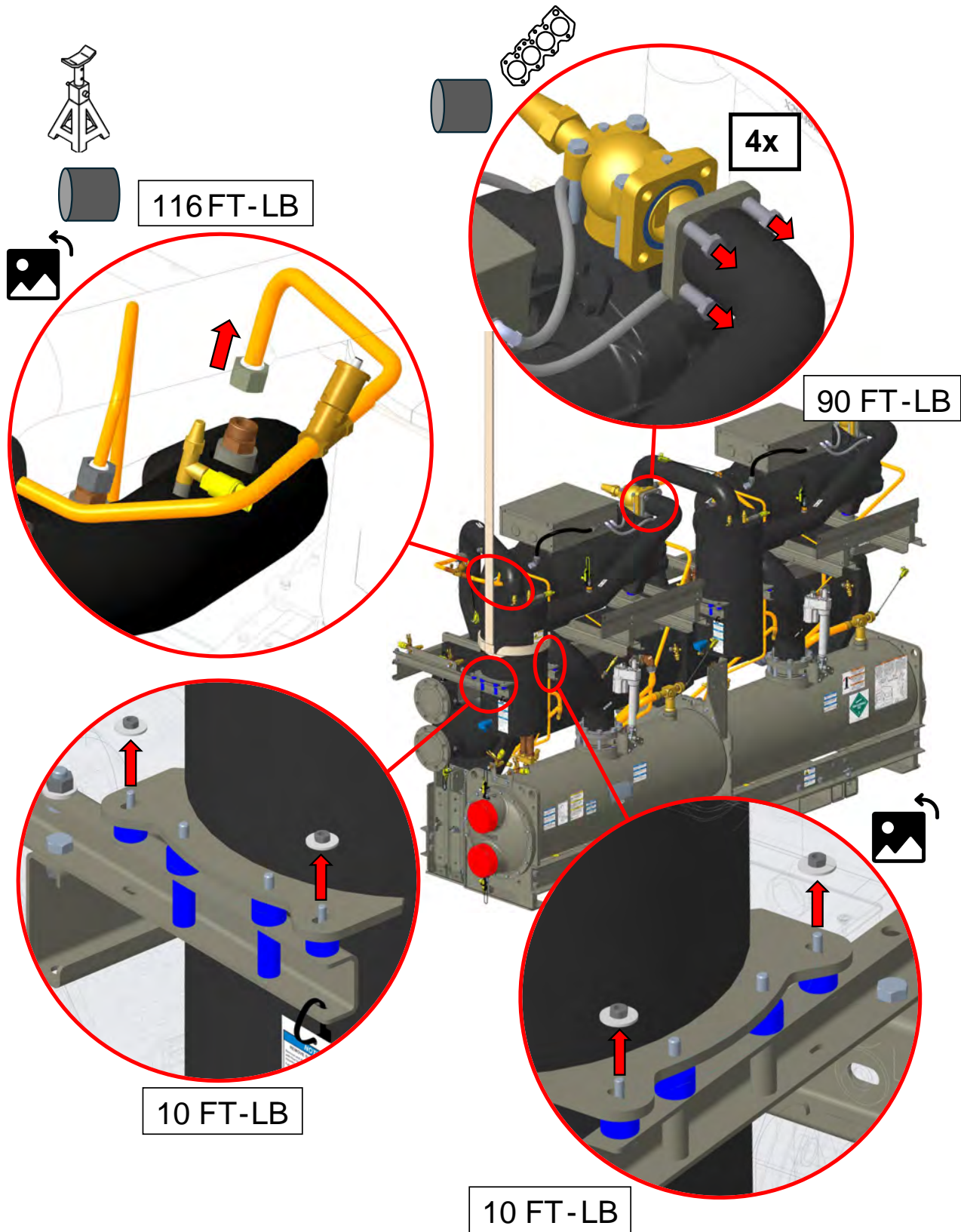

5 – Disassemble Oil Separator Drain Line

Figure 29. Disassemble oil separator drain line

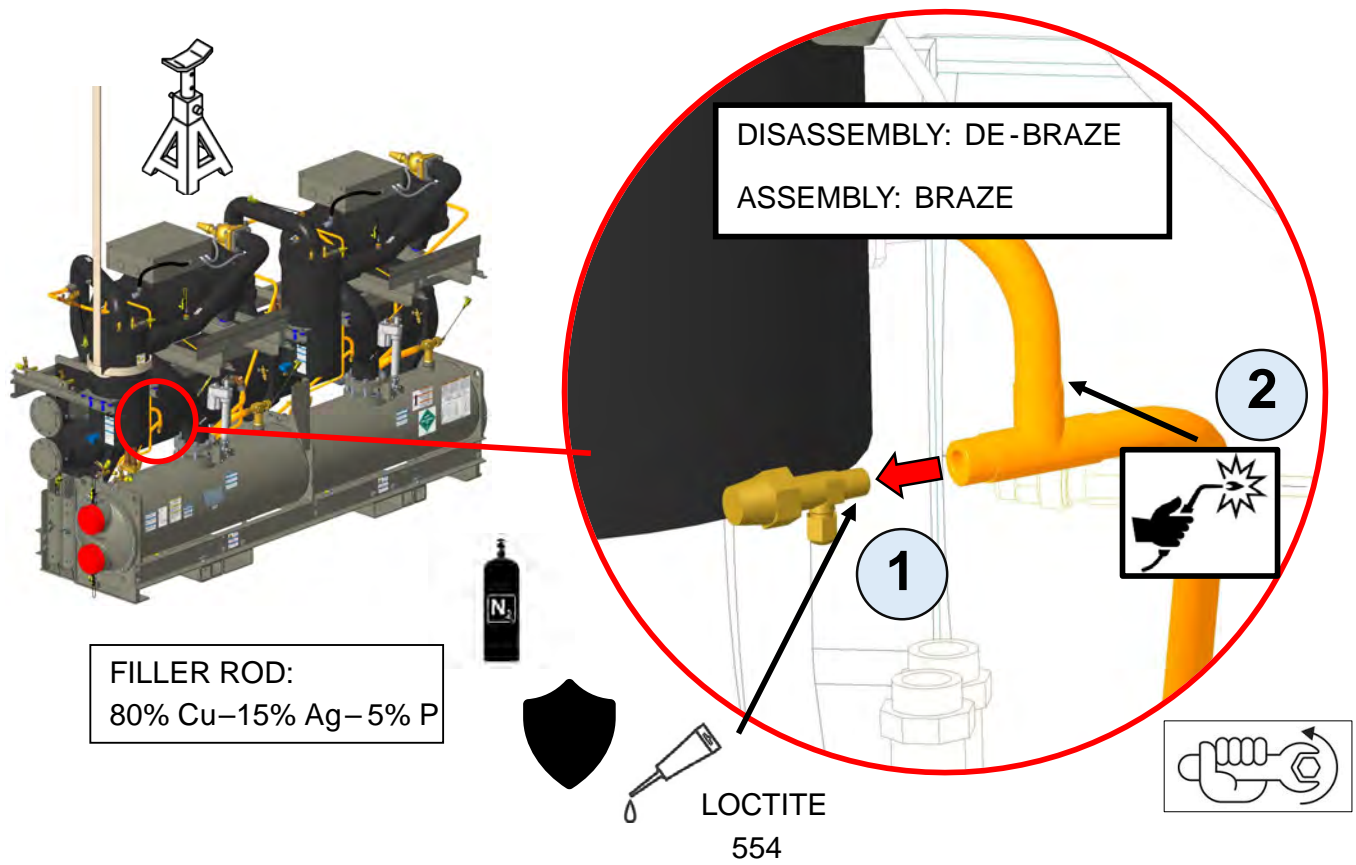

6 – Disassemble Oil Separator Discharge Line

Option 1 – De-braze the Pipe

Figure 30. Disassemble oil separator discharge line

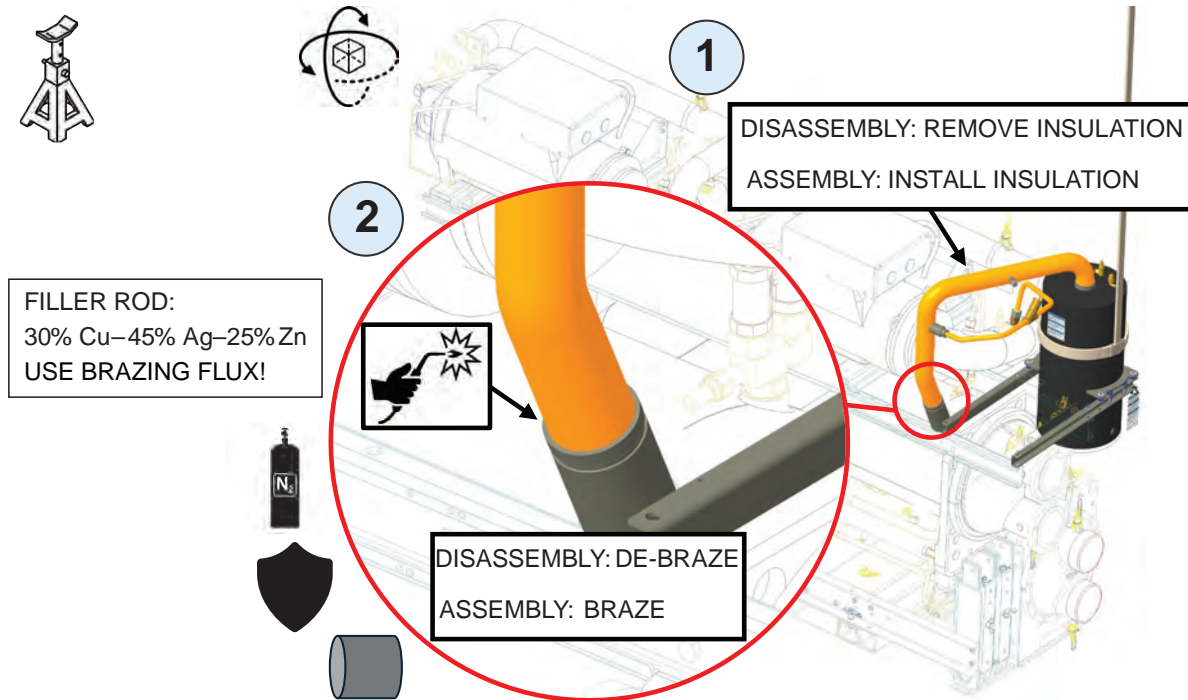

Option 2 – Cut the Pipe

Figure 31. Disassemble oil separator discharge line

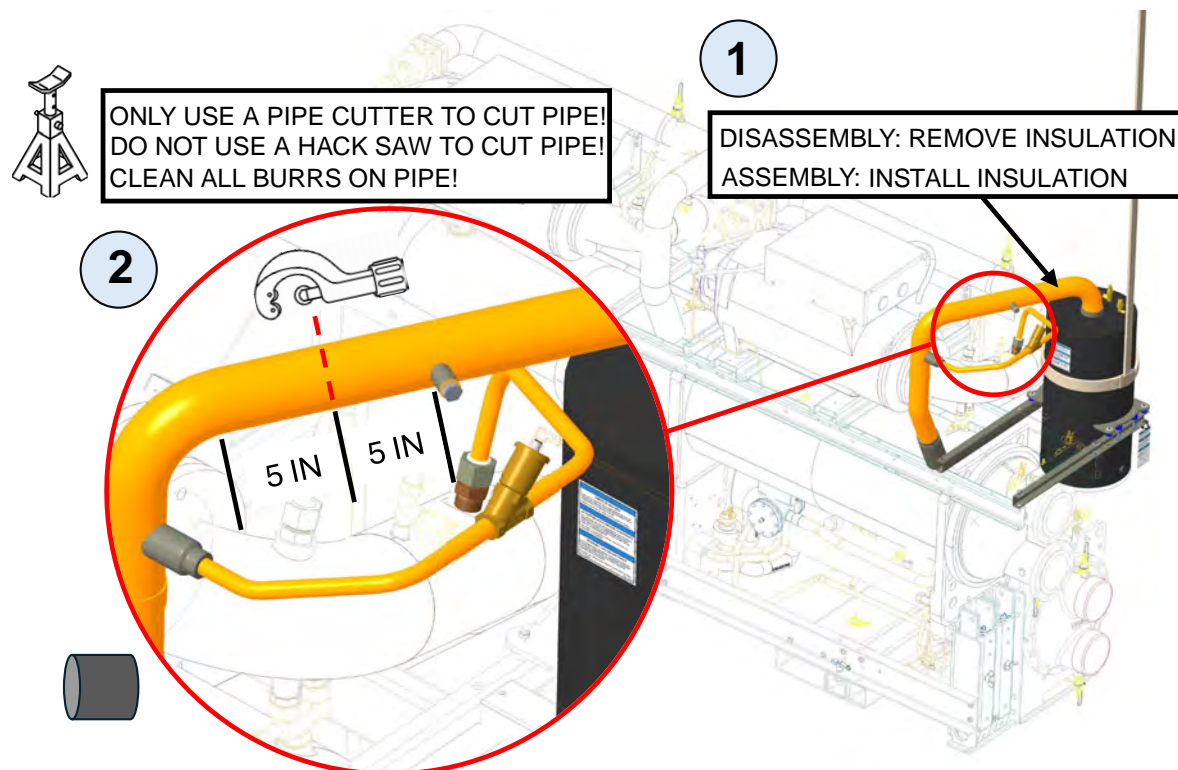

Assembly Only

Figure 32. Disassemble oil separator discharge line

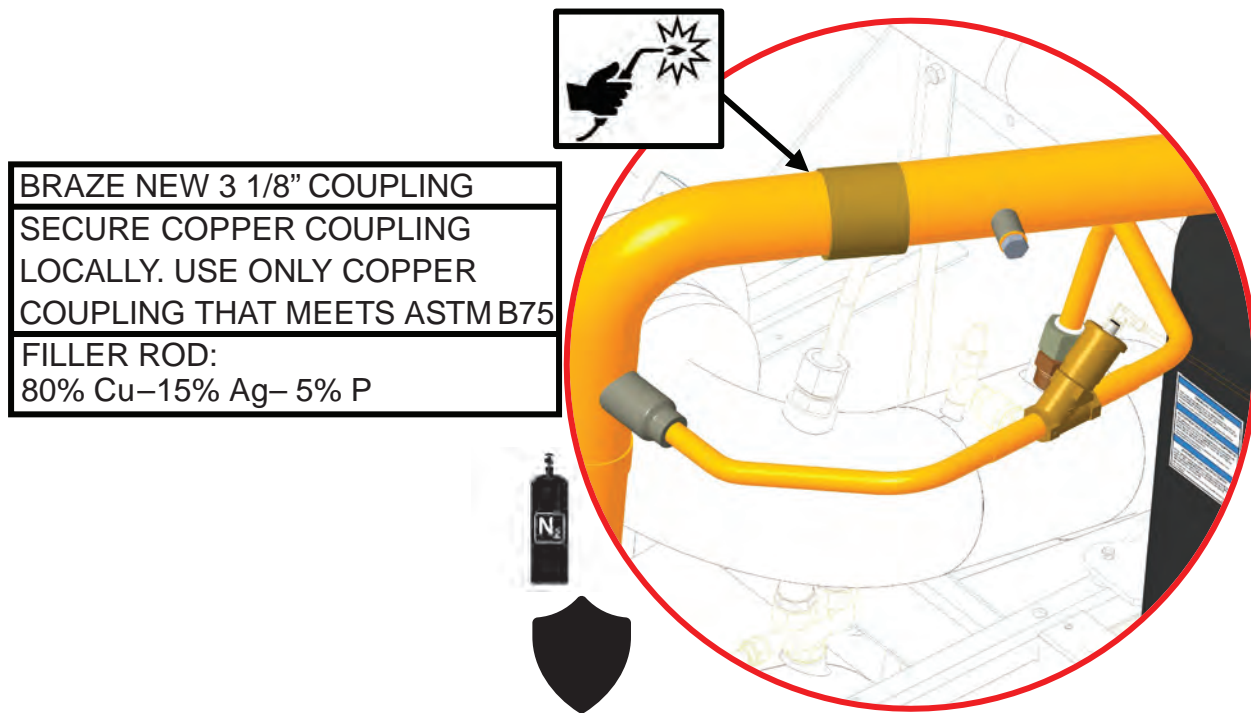

7 – Remove Oil Separator Assembly

Figure 33. Remove oil separator assembly



Repeat steps 1 through 6 for circuit to remove the second oil separator.

10 – Disassemble Suction Line Assembly

Figure 36. Disassemble suction line assembly

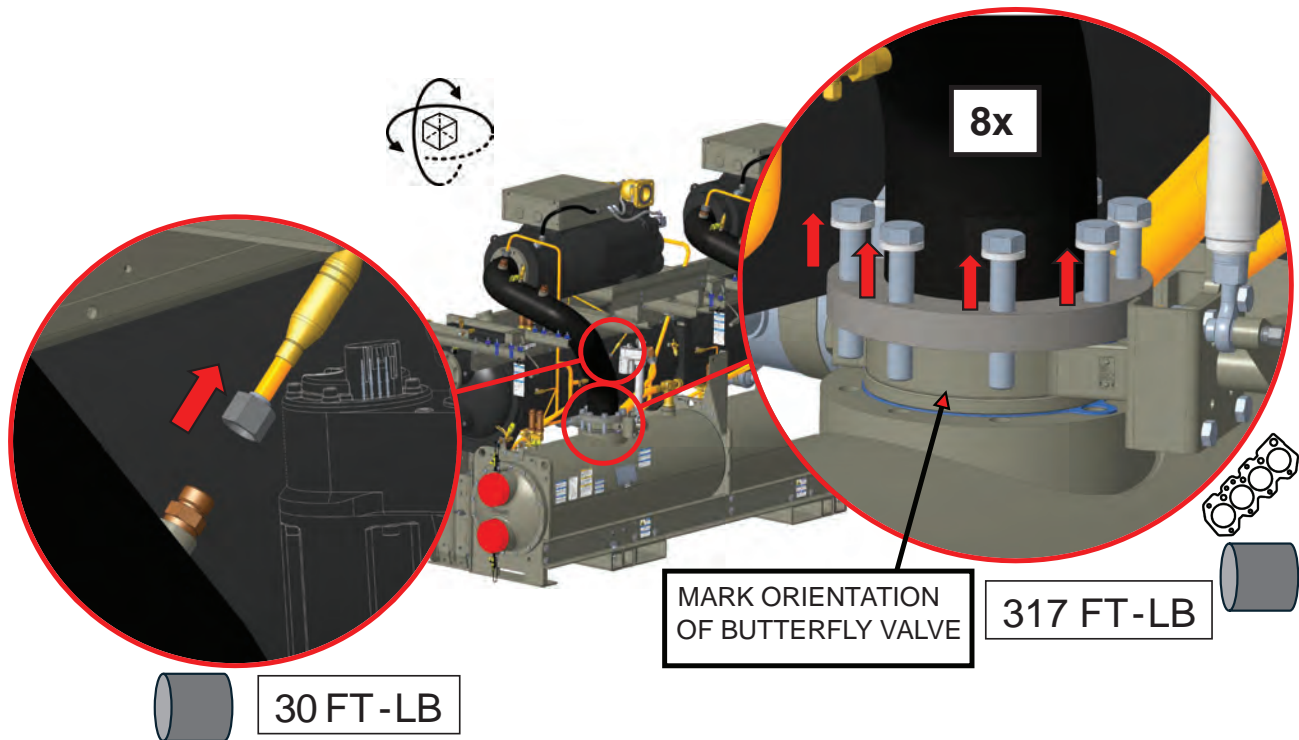

11 – Remove Suction Line Assembly

Figure 37. Remove suction line assembly

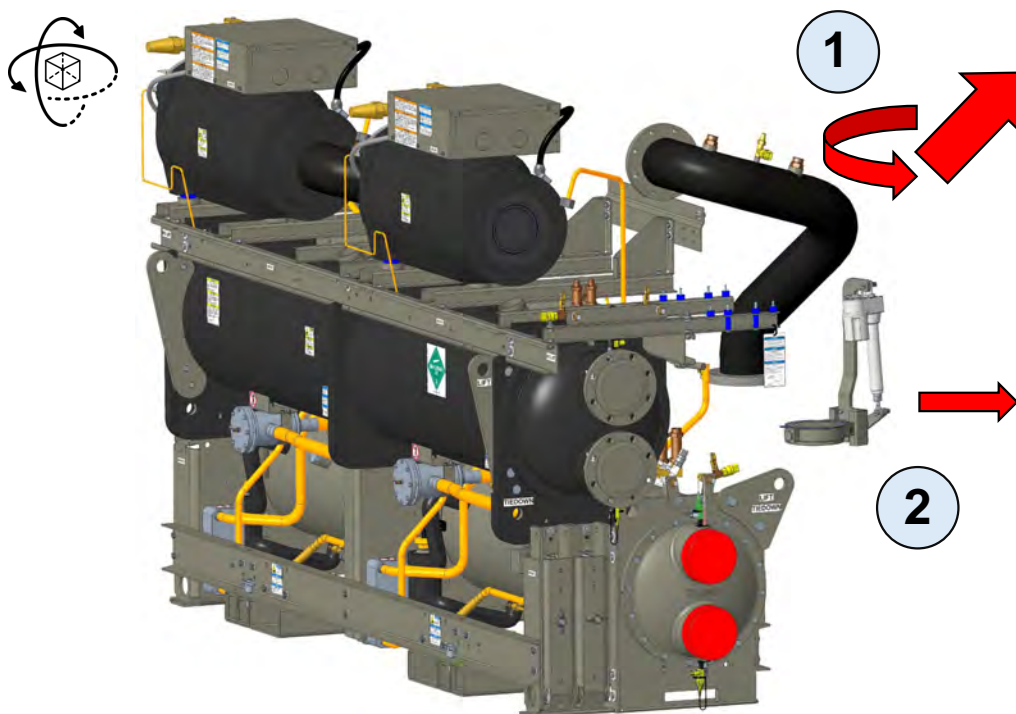

12 – Disassemble Oil Supply Line Mounting

Figure 38. Disassemble oil supply line mounting

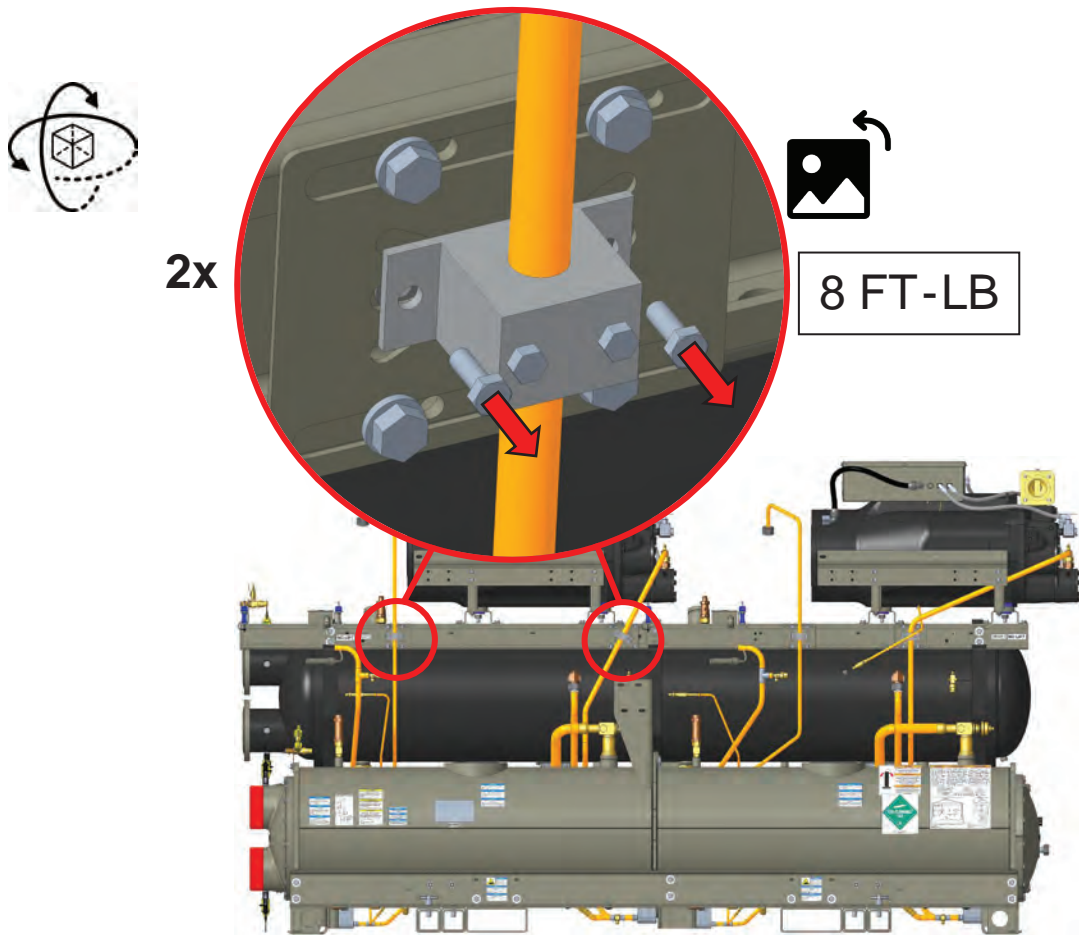

13 – Disassemble Compressor Drain Line

Figure 39. Disassemble compressor drain line

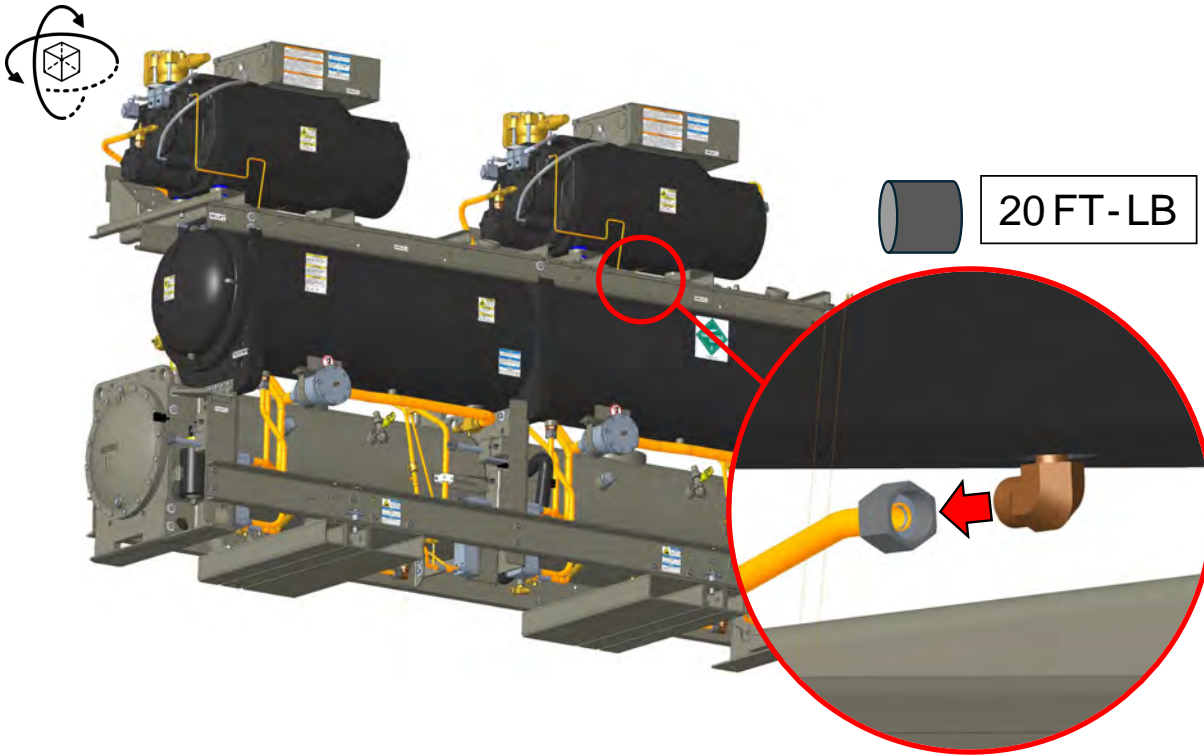

14 – Disassemble Compressor Transducer Assembly

Figure 40. Disassemble compressor transducer assembly

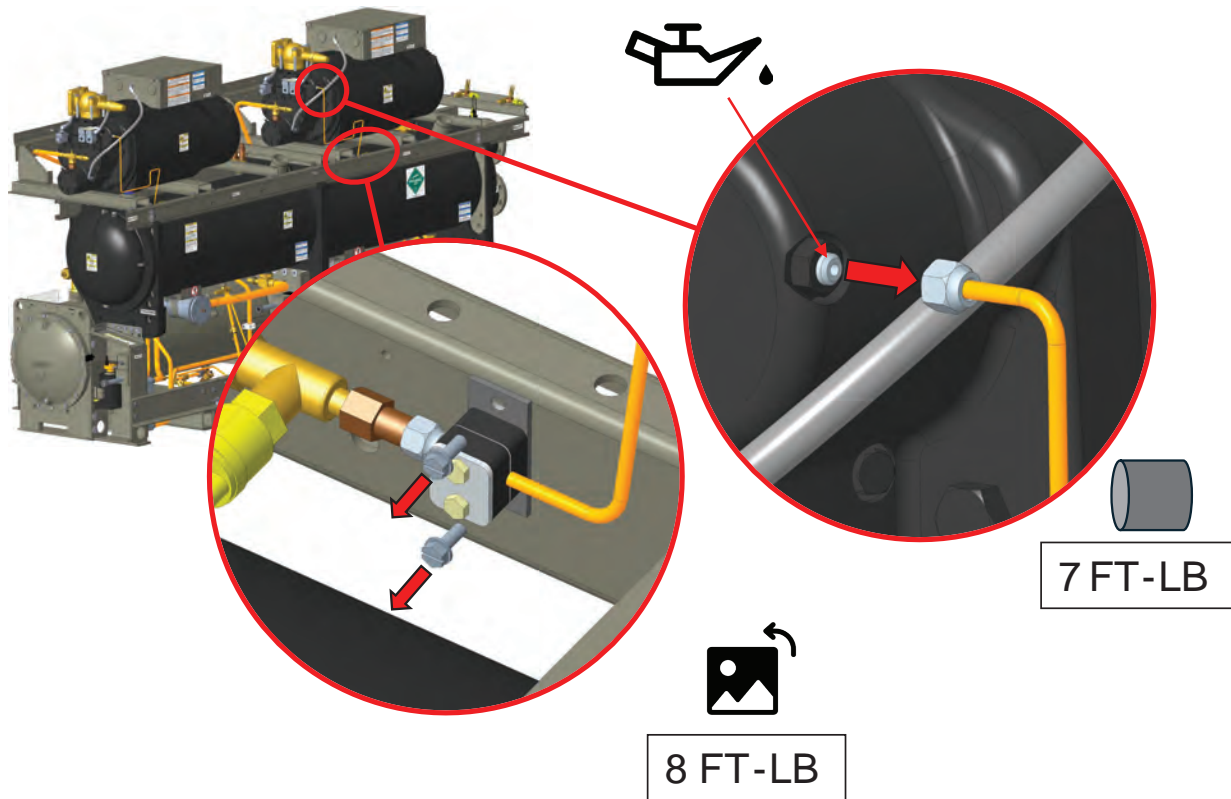

15 – Disassemble Compressor Oil Supply Line

Figure 41. Disassemble compressor oil supply line

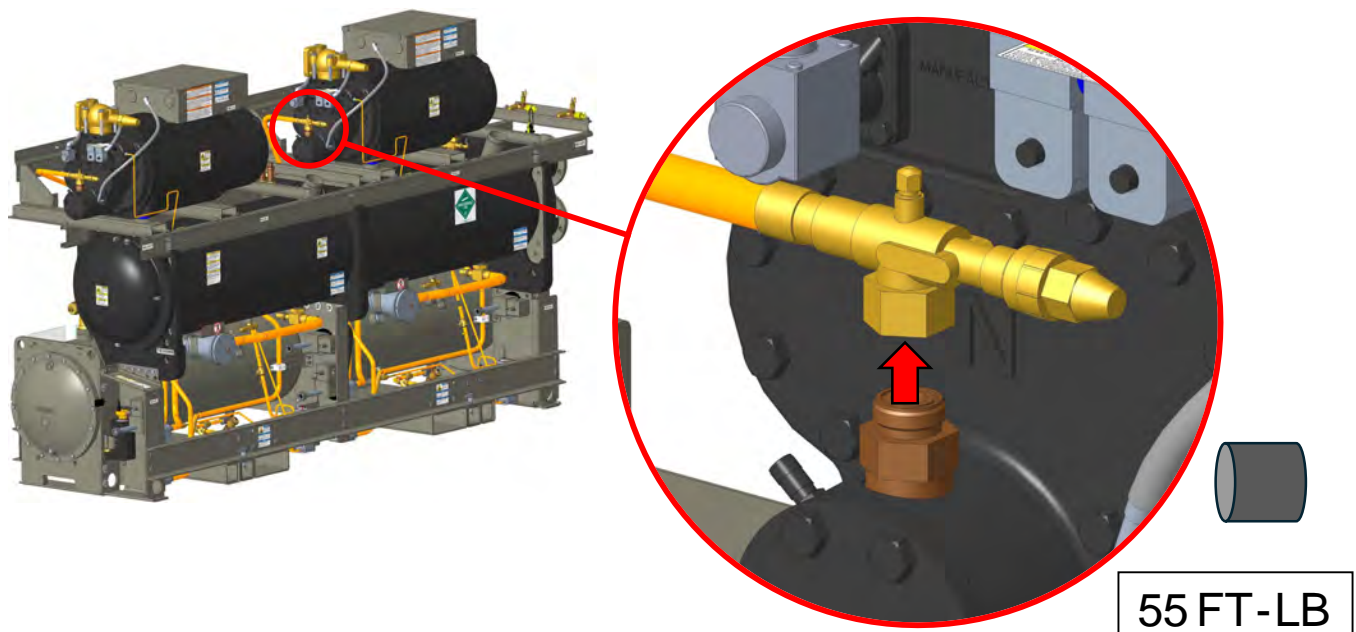

16 – Compressor Lift Support

Figure 42. Compressor lift support

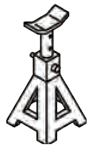

**SUPPORT ONLY!
DO NOT LIFT!**

USE STRAPS RATED FOR
MINIMUM: 1700 LB
COMPRESSOR WEIGHT: 1700 LB

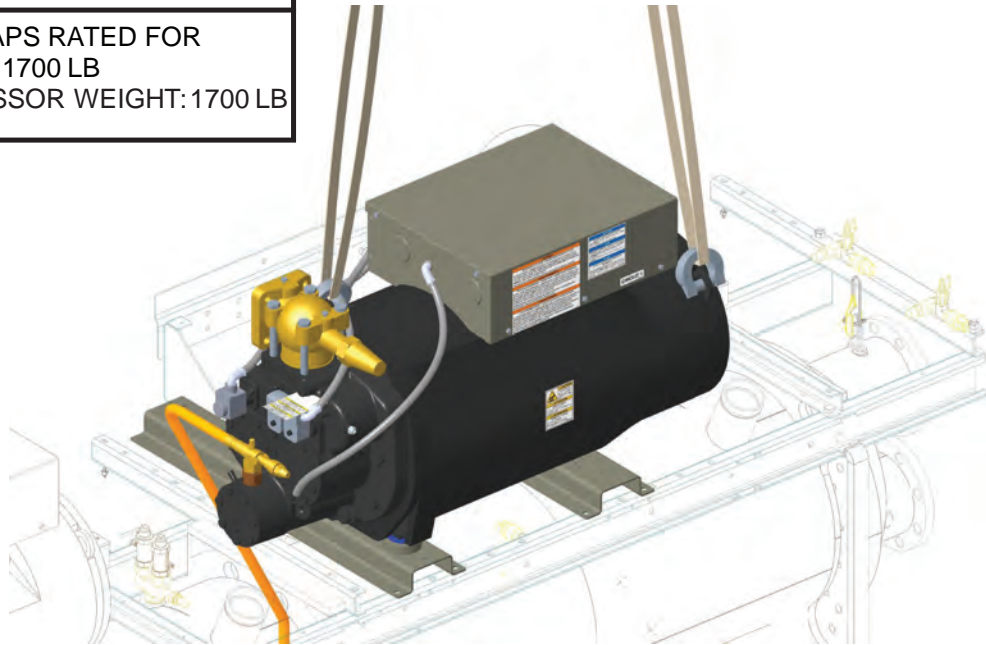

17 – Disassemble Compressor Mounting Hardware

Figure 43. Disassemble compressor mounting hardware

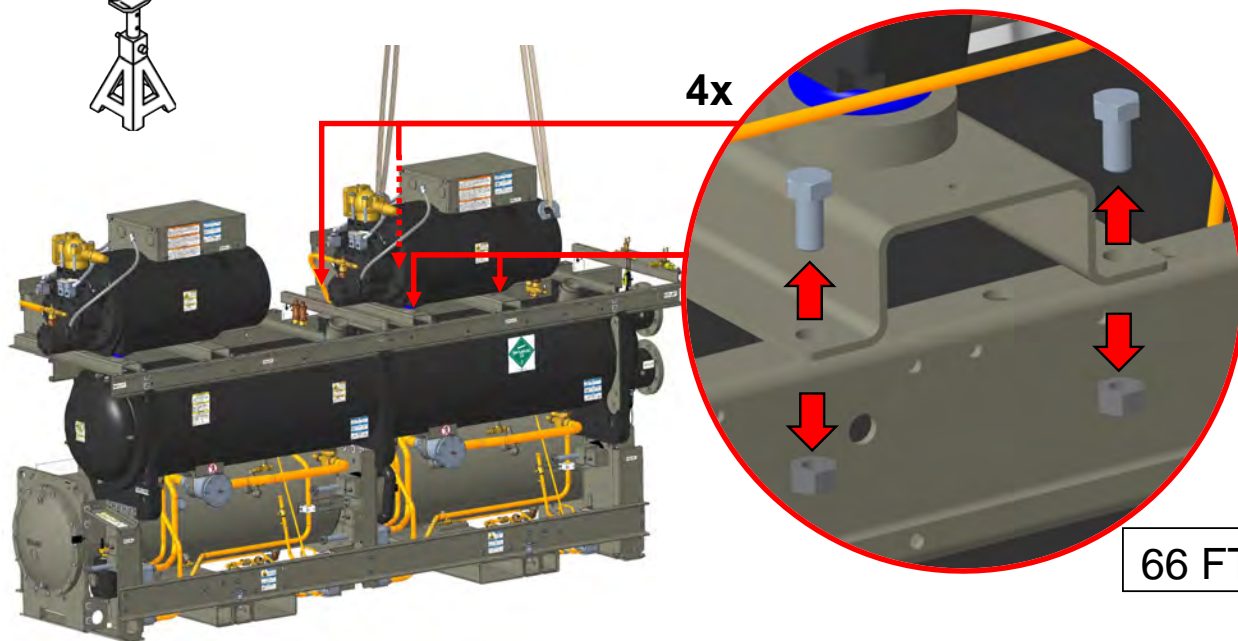
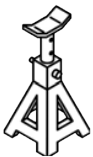

18 – Remove Compressor Assembly

Figure 44. Remove compressor assembly

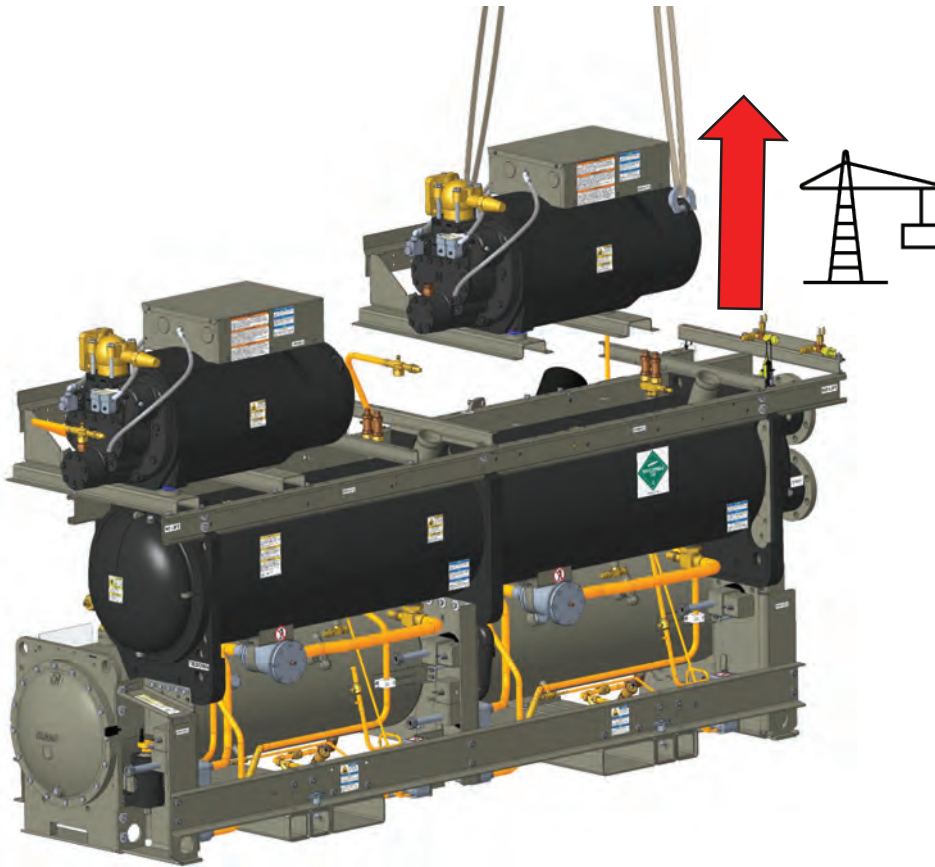

To remove the second compressor, repeat steps 7 through 17.

Parts Removed in this Procedure

Figure 45. Parts removed





Full Disassembly – Removing the Compressor and Oil Separator

Updated Dimensions after Parts Removal

Figure 46. Updated dimensions

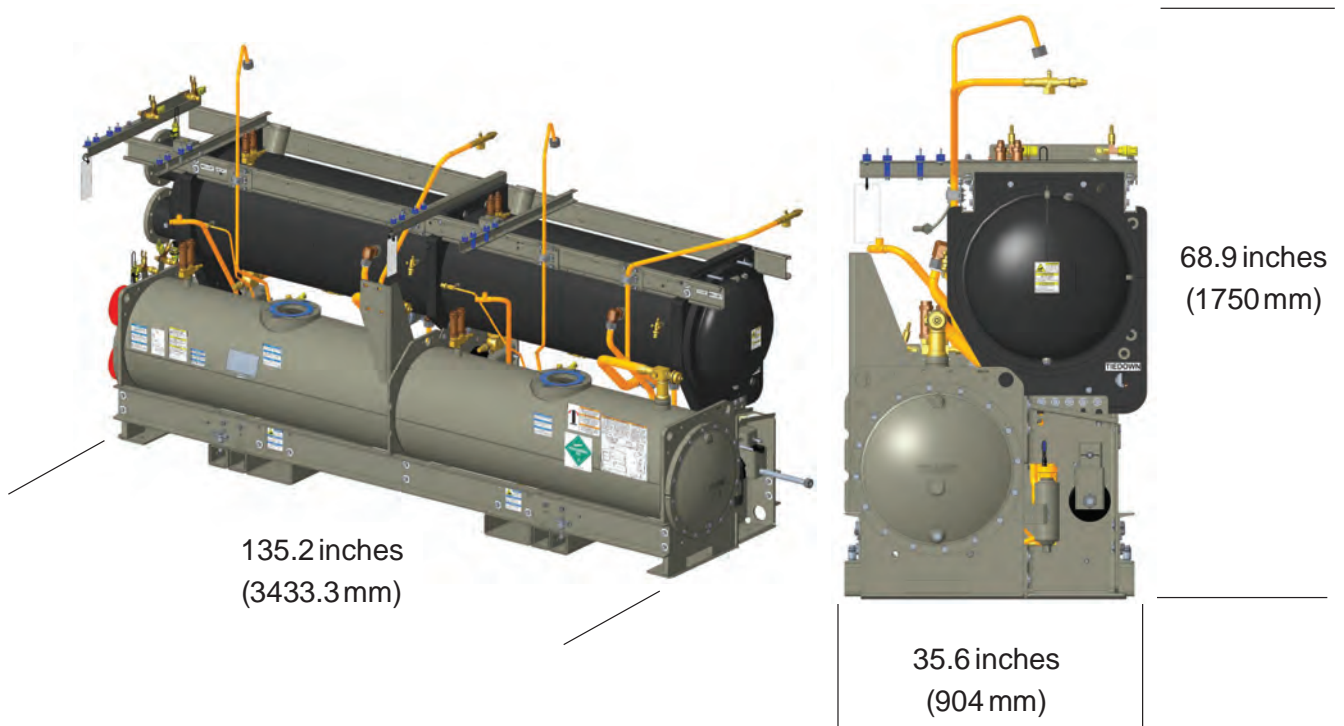

Removing the Condenser

1 – Disassemble Condenser Wire Connectors

Figure 47. Disassemble condenser wire connectors

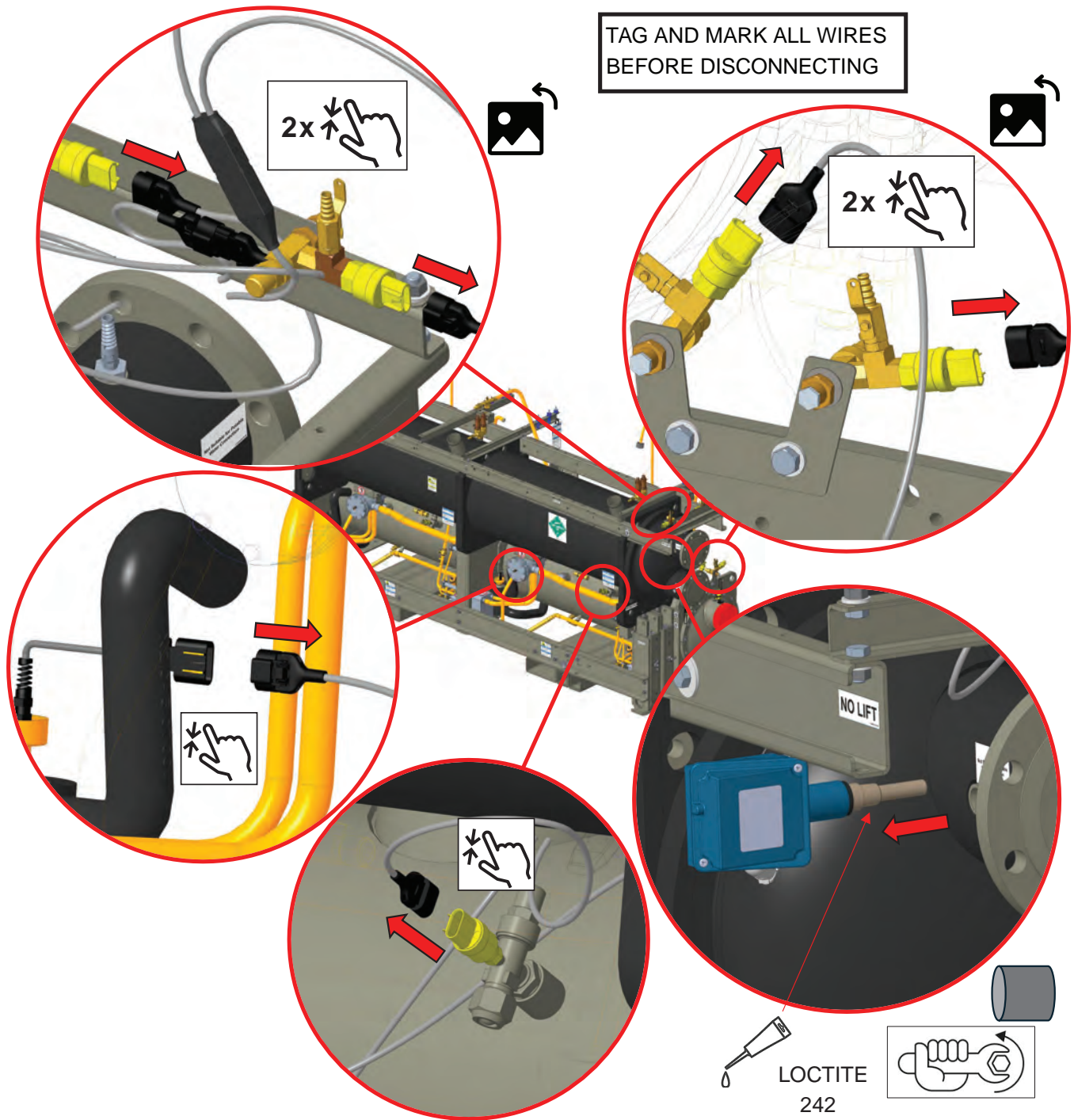

2 – Disassemble Flow Proving Wiring

Figure 48. Disassemble flow proving wiring

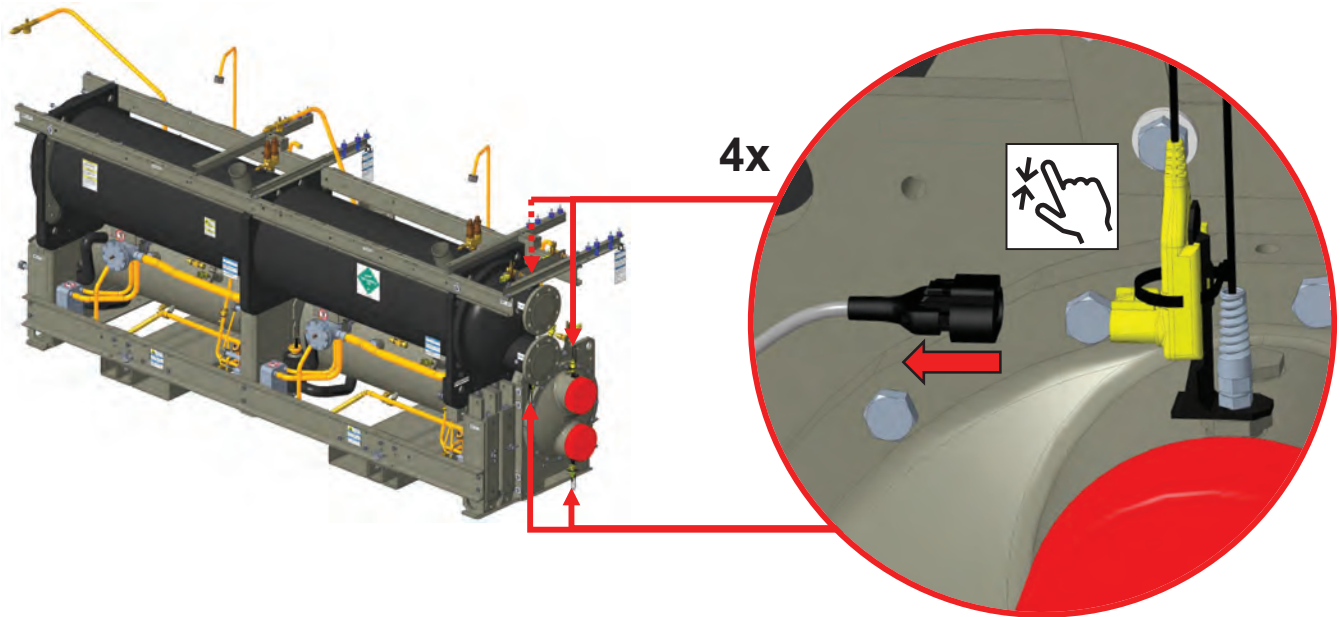

3 – Condenser Lift Support

Important: Steps 3 through 5 are optional to reduce the unit size.

Figure 49. Condenser lift support

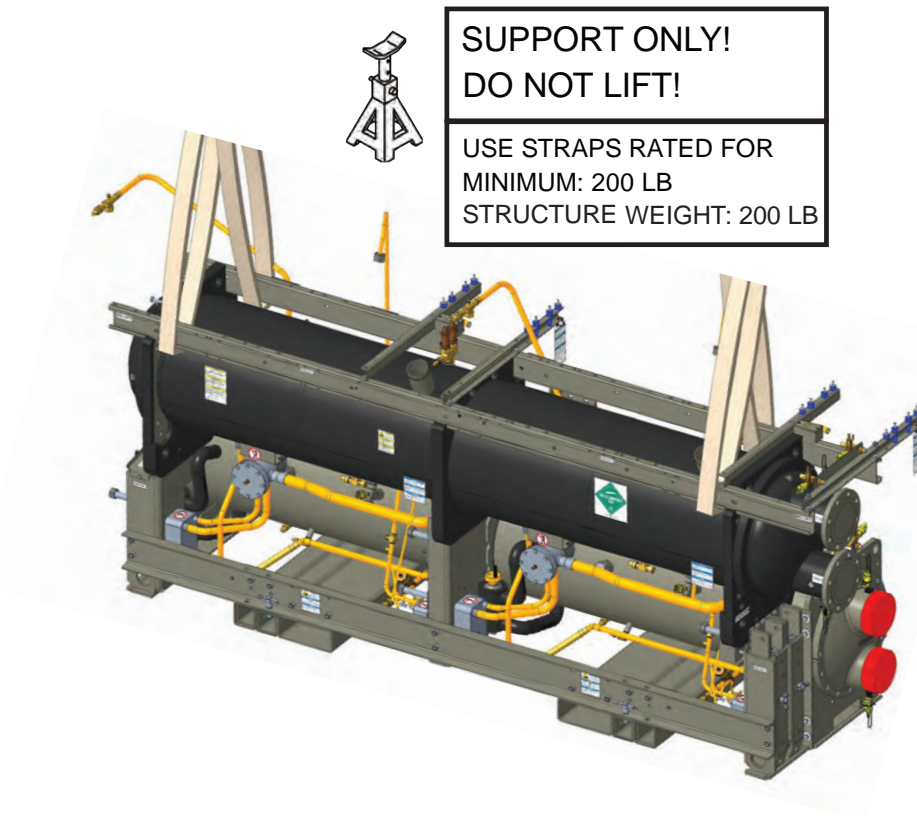

4 – Disassemble Base Rail Mounting Hardware

Figure 50. Disassemble base rail mounting hardware

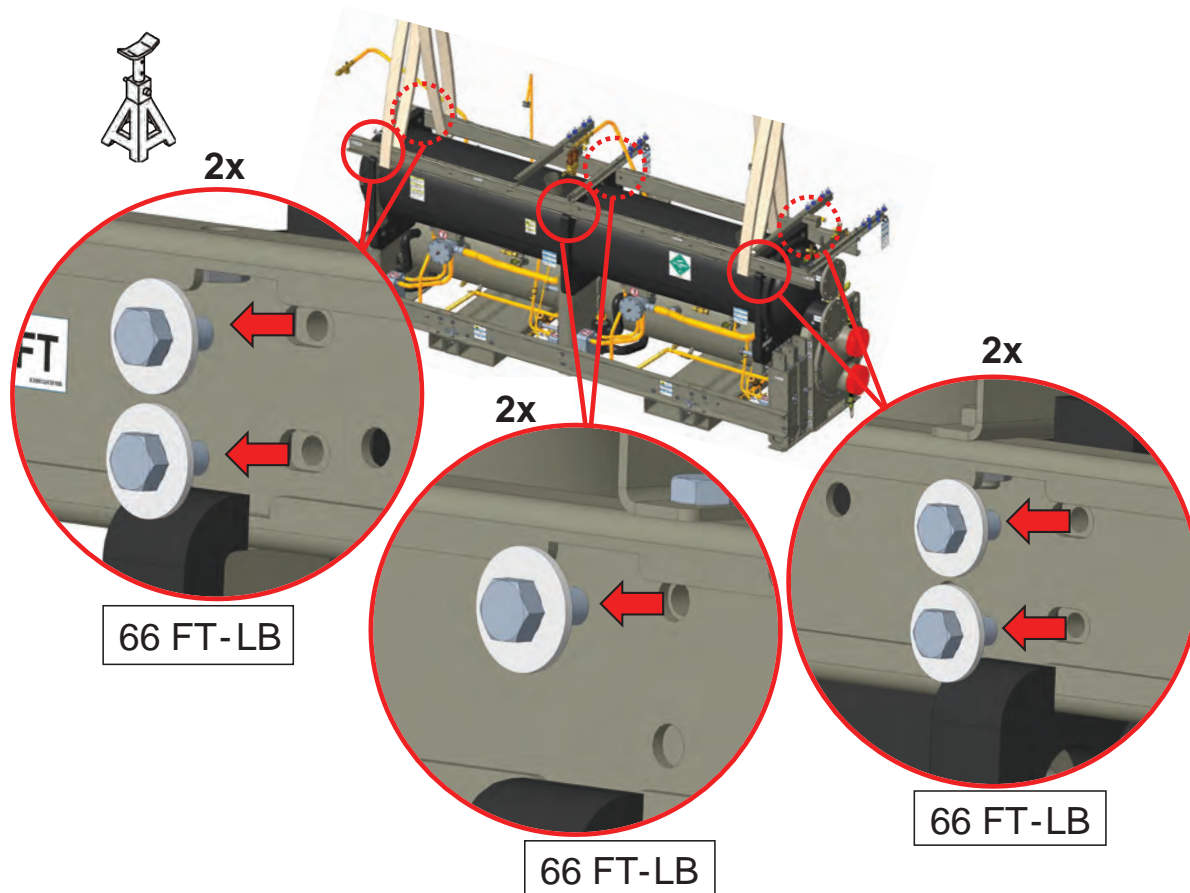

5 – Remove Base Rail Assembly

Figure 51. Remove base rail assembly



6 – Disassemble Condenser Piping

Figure 52. Disassemble condenser piping

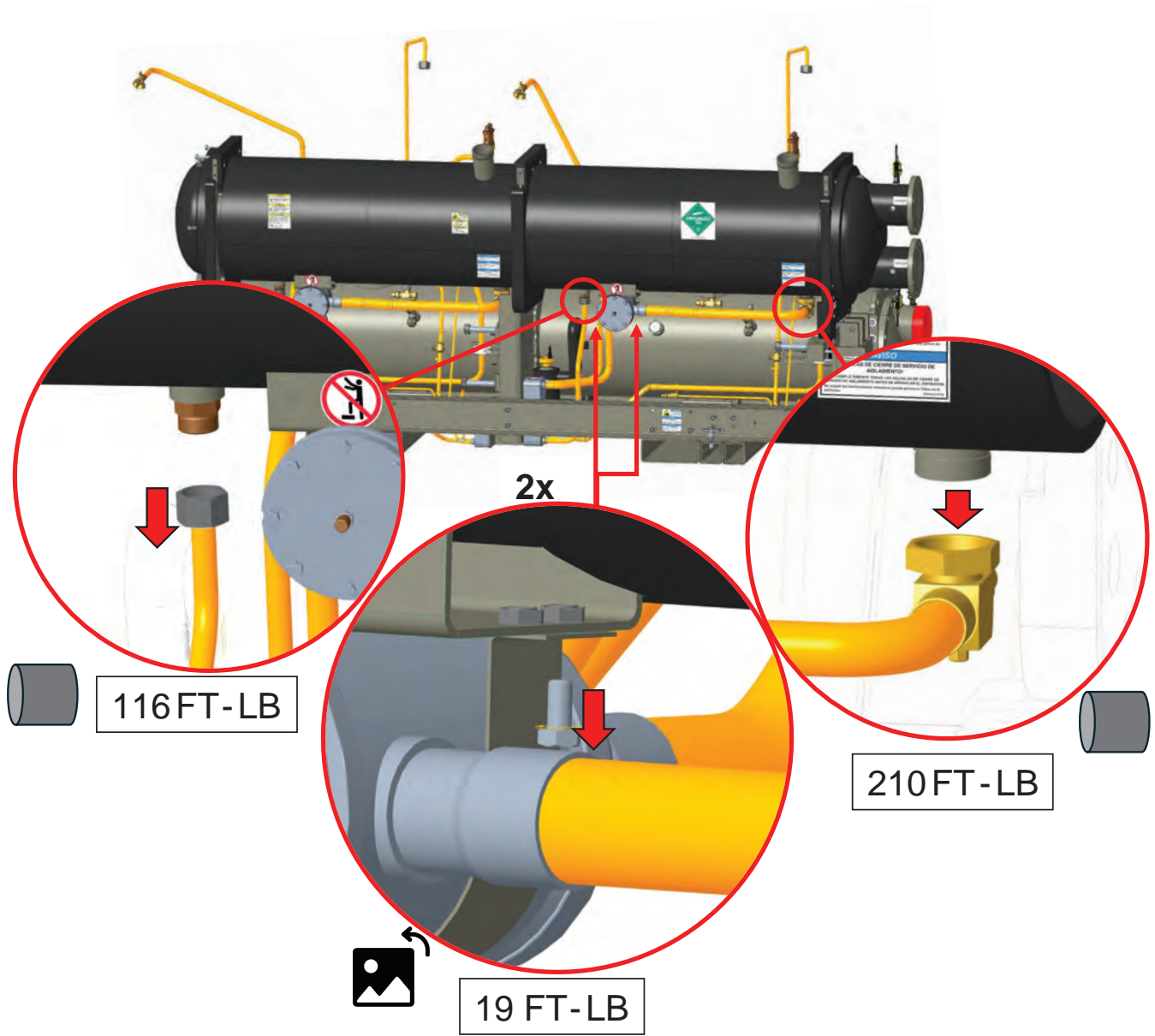

7 – Disassemble Condenser Piping and EXV

Figure 53. Disassemble condenser piping and EXV

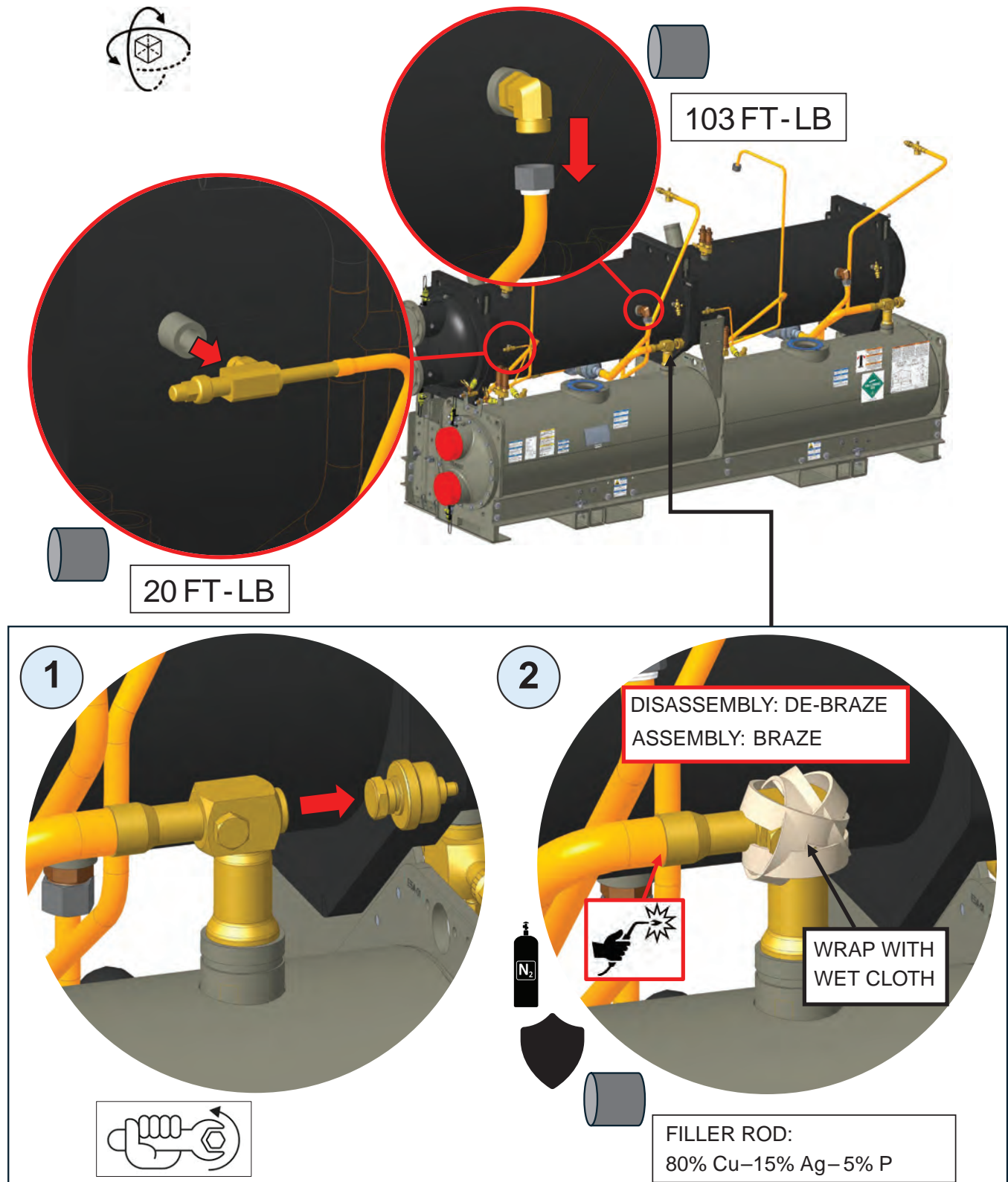

8 – Remove Liquid Line Assembly

Figure 54. Remove liquid line assembly

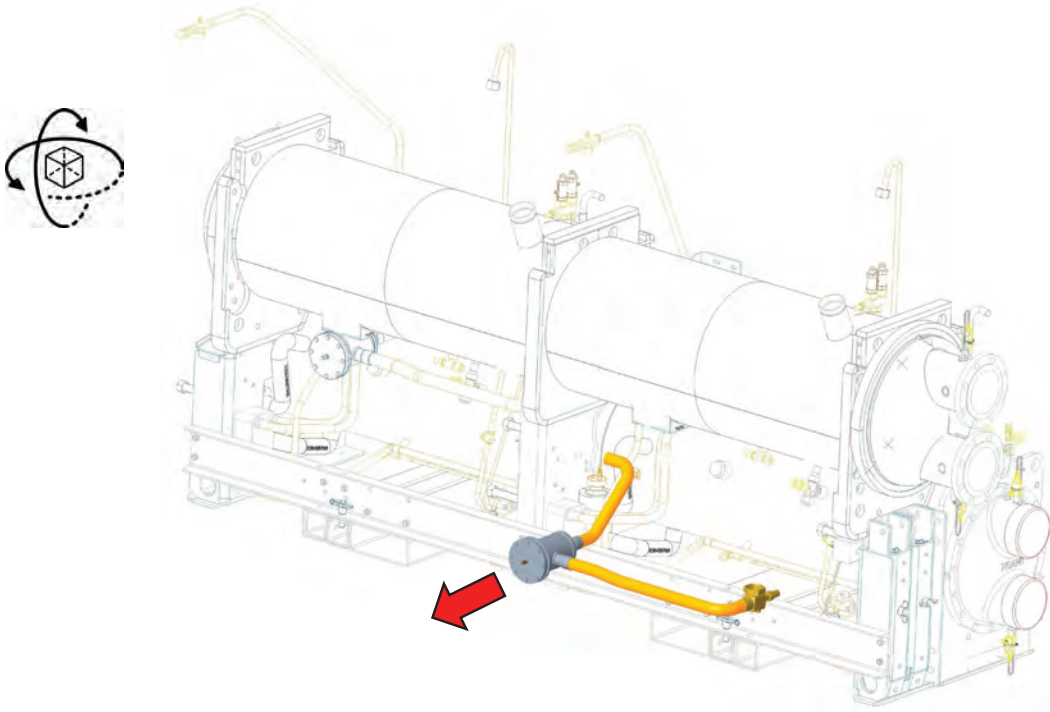

Repeat steps 1 through 8 for Circuit 2.

9 – Lift Support Condenser Assembly

Figure 55. Lift support condenser assembly

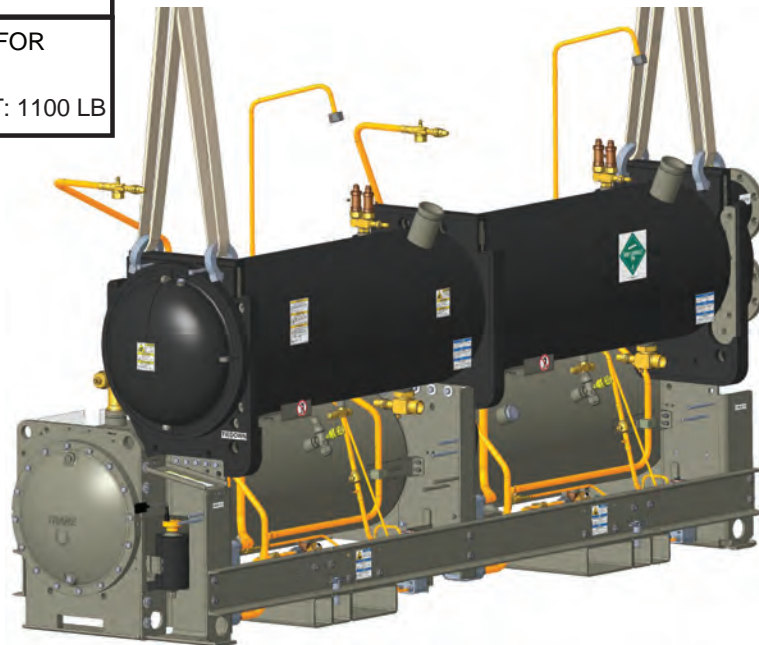
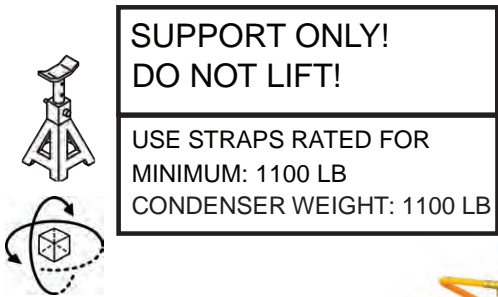

10 – Disassemble Condenser Mounting Hardware

Figure 56. Disassemble condenser mounting hardware

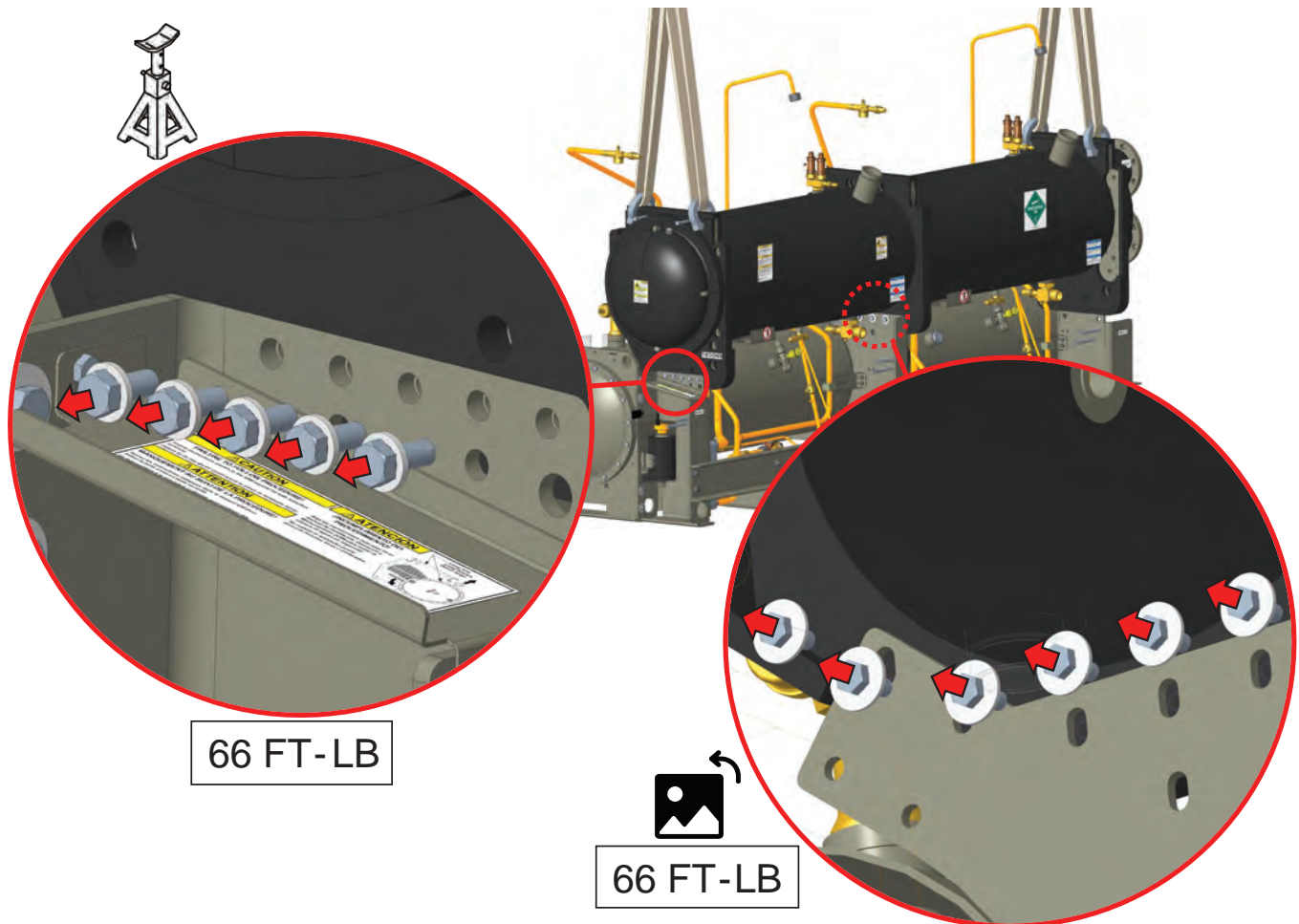

11 – Disassemble Condenser Mounting Hardware

Figure 57. Disassemble condenser mounting hardware

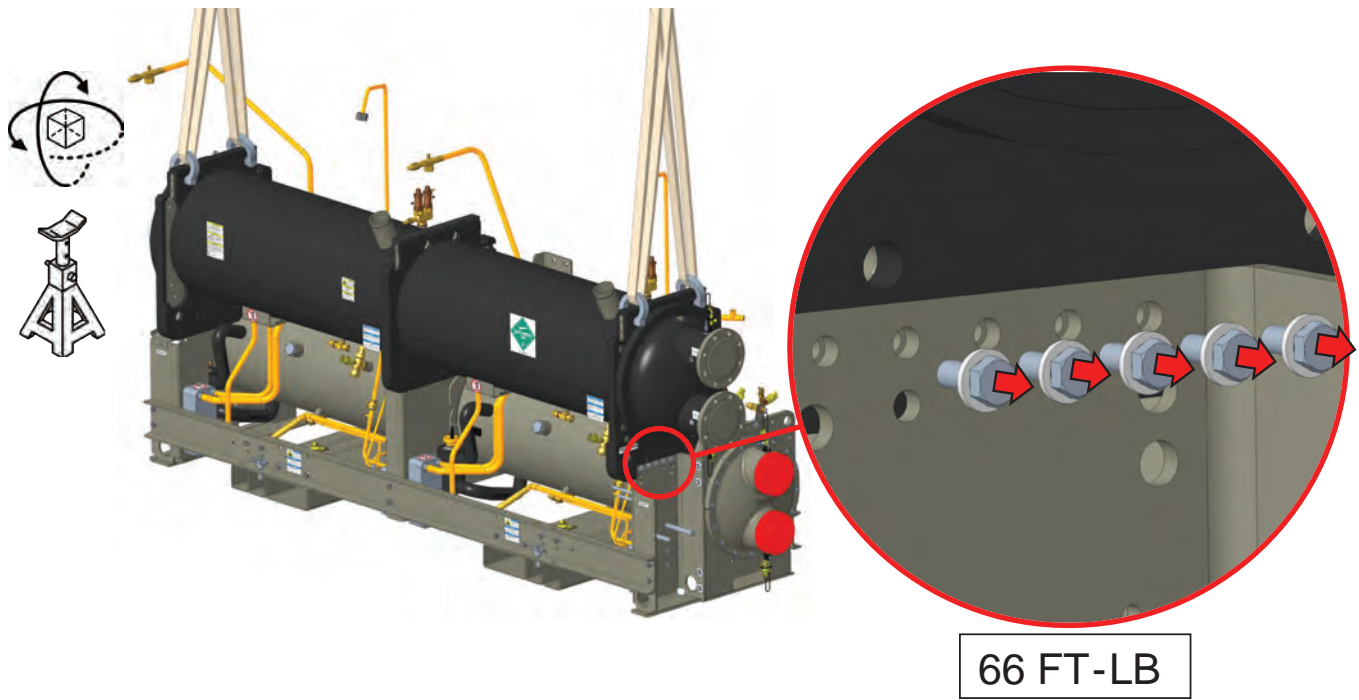

12 – Remove Condenser Assembly

Figure 58. Remove condenser assembly



13 – Disassemble Evaporator Piping

Figure 59. Disassemble evaporator piping

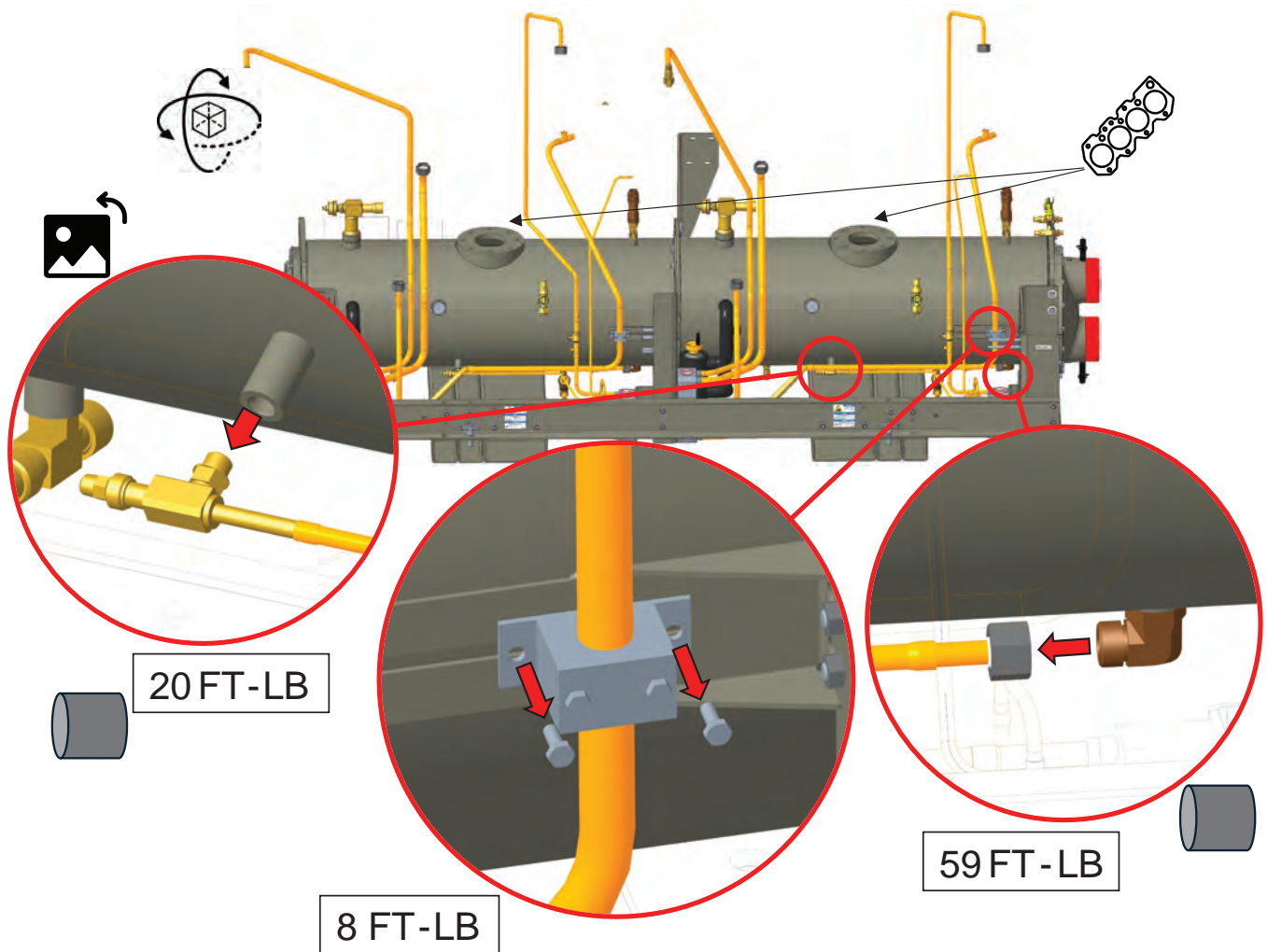

14 – Disassemble Thermosyphon Assembly

Figure 60. Disassemble thermosyphon assembly

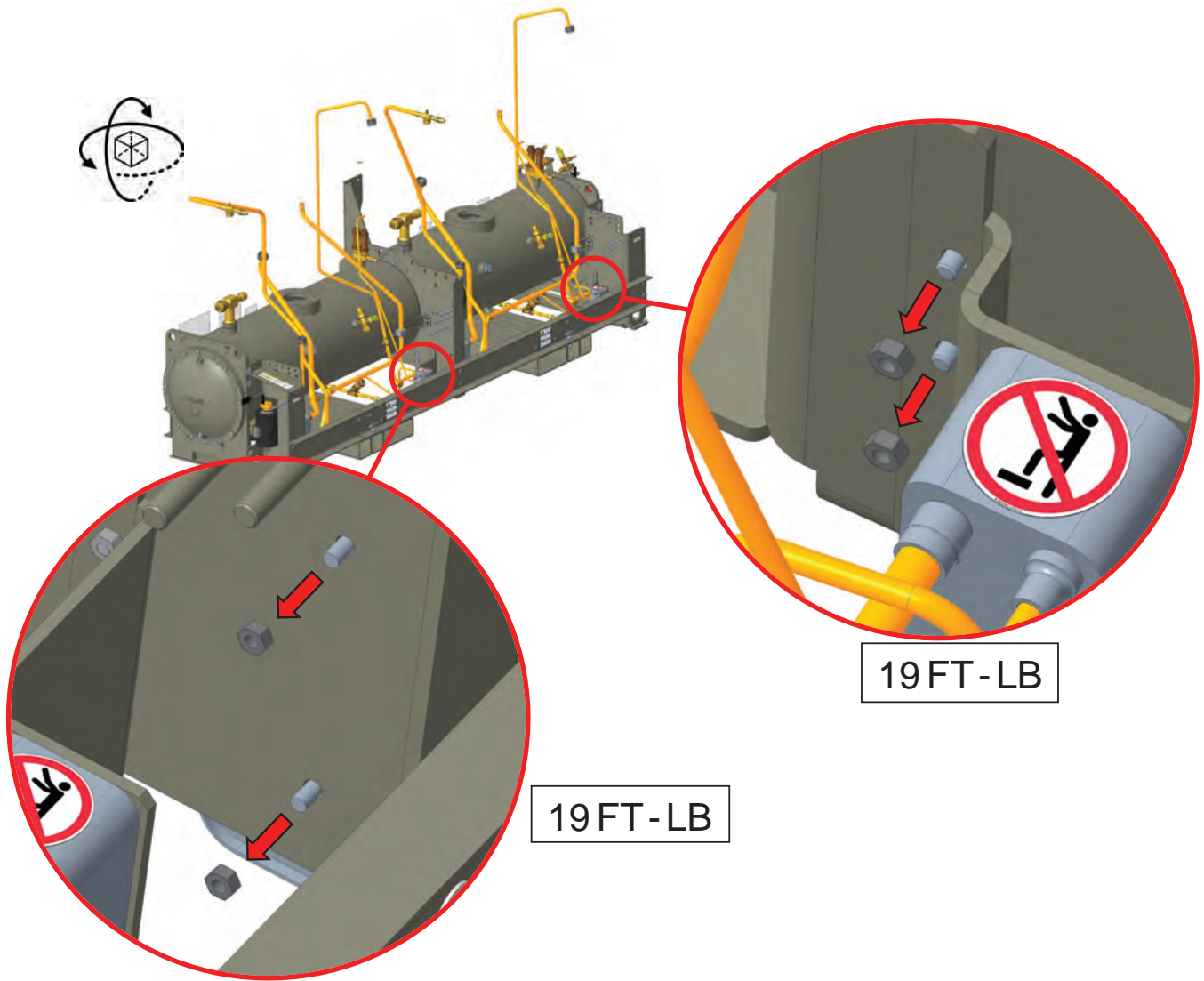

15 – Remove Circuit 1 Thermosyphon Assembly

Figure 61. Remove circuit 1 thermosyphon assembly

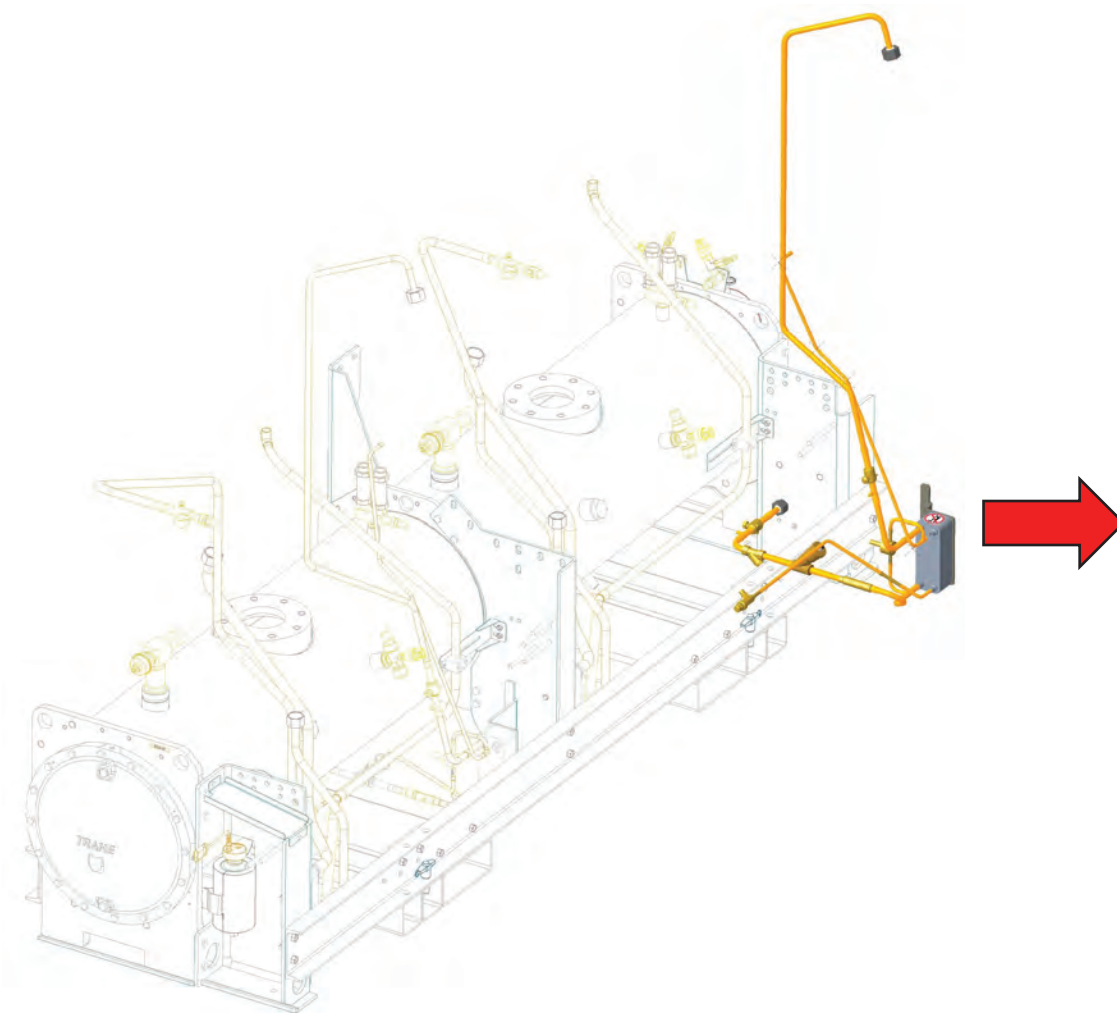

16 – Remove Circuit 2 Thermosyphon Assembly

Figure 62. Remove circuit 2 thermosyphon assembly

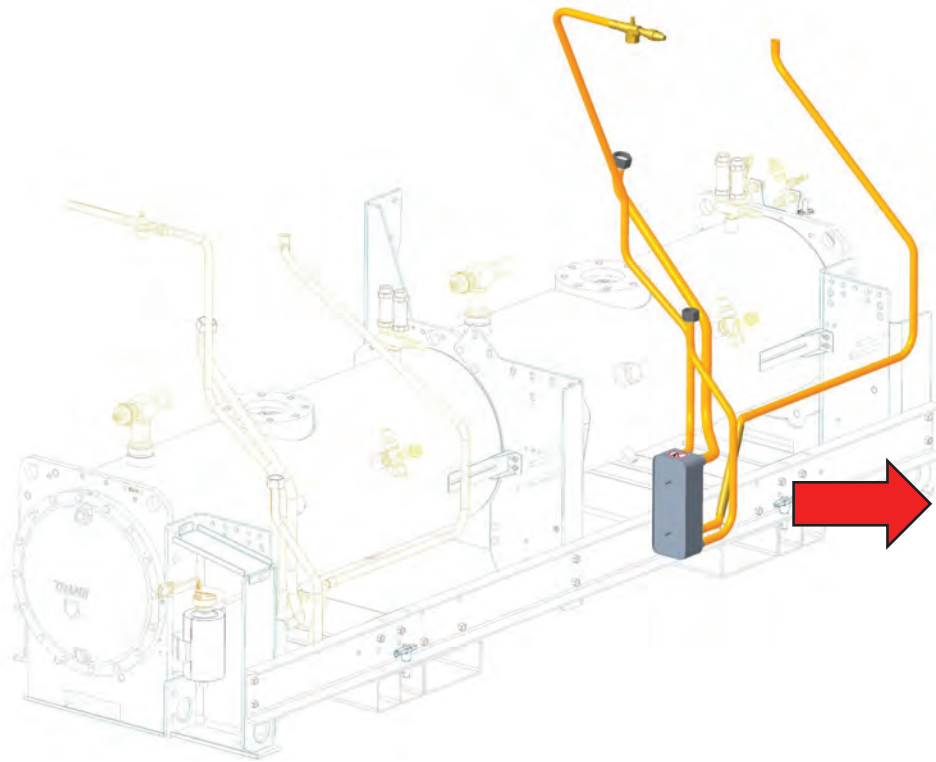

Repeat steps 13 through 16 for Circuit 2.

17 – Disassemble Control Panel Mounting Support

Important: This step is optional to reduce the unit size.

Figure 63. Disassemble control panel mounting support

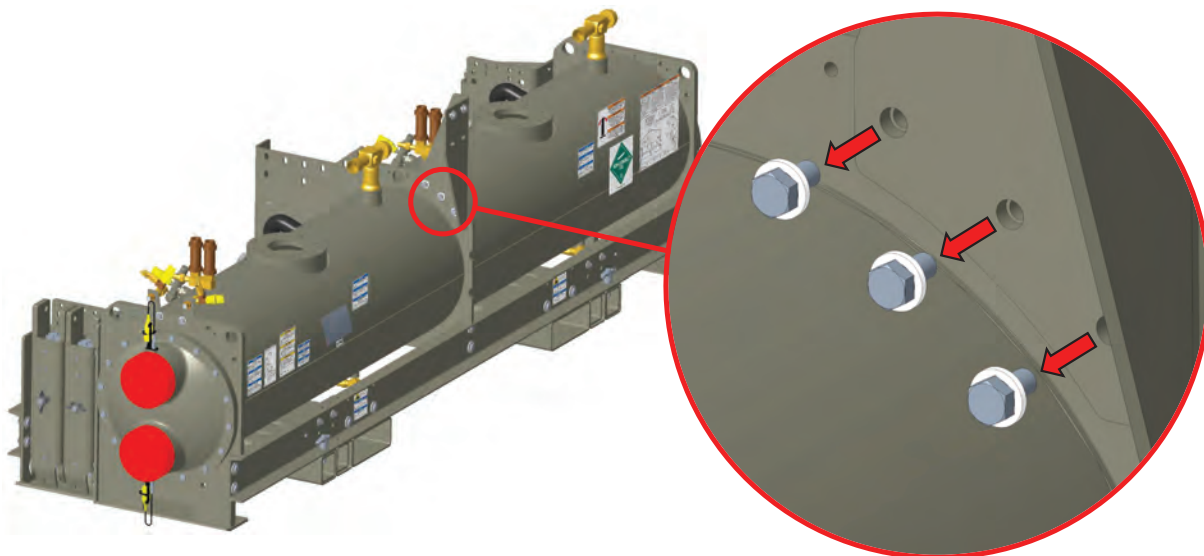

66 FT-LB

Parts Removed in this Procedure

Figure 64. Parts removed

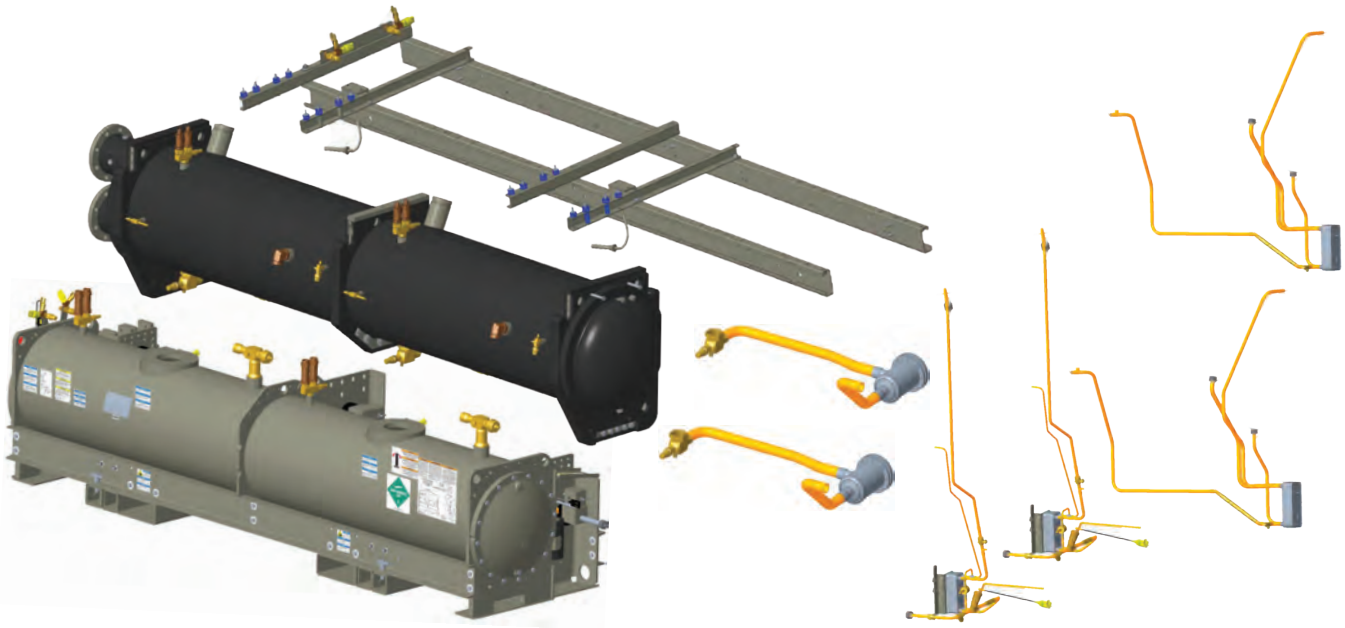

Updated Dimensions after Parts Removal

Figure 65. Updated dimensions



Trane - by Trane Technologies (NYSE: TT), a global innovator - creates comfortable, energy efficient indoor environments for commercial and residential applications. For more information, please visit trane.com or tranetechnologies.com.

Trane has a policy of continuous product and product data improvements and reserves the right to change design and specifications without notice. We are committed to using environmentally conscious print practices.

RLC-SVN009A-EN 15 May 2026
Supersedes (New)

©2026 Trane