

Installation Manual

Mini-Split Inverter System

23 SEER (R-410A) High Wall Unit

9,000 - 36,000 Btu/h - 60 Hz



Outdoor Unit Heat Pump:

4TXK2309A1
4TXK2312A1
4TXK2318A1
4TXK2324A1
4TXK2330A1
4TXK2336A1

AC Outdoor Unit:

4TYK2309A1/9
4TYK2312A1/9
4TYK2318A1
4TYK2324A1
4TYK2330A1
4TYK2336A1

Indoor Unit Heat Pump:

4MXW2309A1
4MXW2312A1
4MXW2318A1
4MXW2324A1
4MXW2330A1
4MXW2336A1

AC Indoor Unit:

4MYW2309A1
4MYW2312A1
4MYW2318A1
4MYW2324A1
4MYW2330A1
4MYW2336A1

Catalogue number: MS-SVN066B-EN

Date: April 9, 2019

Replace: MS-SVN066A-EN

The manufacturer follows a policy of continued improvement of their products and product data and reserve the right to change designs and specifications without prior notice. Only qualified technicians should install and service the equipment mentioned within the present manual.



© 2019 Trane. All rights reserved.

April, 2019

MS-SVN066B-EN

Warnings and cautions

Warnings and cautions. Warnings are provided to alert installing contractors about potential hazards that could result in personal injury or death, while cautions are designed to alert personnel about conditions that could result in minor injury and equipment damage. Your personal safety and the proper operation of this machine depend upon the strict observance of these precautions.

Attention: Warnings and cautions appear at appropriate sections throughout this manual. Read these carefully.

⚠ WARNING: Indicates a potentially hazardous situation which, if not avoided, could lead to death or serious injury.

⚠ CAUTION: Indicates a potentially hazardous situation which, if not avoided, could result in minor or moderate injuries. It may also be used to alert against unsafe practices.

NOTICE: Indicates a situation that could result in equipment or property-damage only.

⚠ WARNING

This equipment is to be serviced by professionally trained personnel ONLY. Under NO circumstances should unqualified personnel service this equipment. This equipment contains refrigerant under PRESSURE and it operates at HIGH VOLTAGE. Improperly installed, adjusted or altered equipment by unqualified personnel poses safety hazards including FIRE, ELECTROCUTION or EXPLOSION which could lead to death or serious injury.

⚠ WARNING

Electrocution and Fire Hazards with improperly installed and grounded field wiring!

Improperly installed and grounded field wiring poses FIRE AND ELECTROCUTION hazards. To avoid these hazards, you MUST follow requirements for field wiring installation and grounding as described in the National Electrical Codes (NEC) and your local/state electrical codes. All field wiring MUST be performed by qualified personnel. Failure to follow these requirements could lead to death or serious injury.

Warnings and cautions

WARNING

R410A Refrigerant under higher pressure than R-22 Refrigerant!

Units described in this manual use R410-A refrigerant which operates at 50 to 70% higher pressures than R-22. Use only R-410A approved service equipment. Refrigerant cylinders are painted with "pink" color to indicate the type of refrigerant and may contain a "dip" tube to allow for charging of liquid refrigerant into the system. For specific handling concerns with R-410A, contact your local Trane representative.

Failure to use R-410A approved service equipment could lead to standard equipment exploding under R410A higher pressure and as a consequence could result in death or serious injury.

NOTICE

Use PVE Oil with R-410-A mini-split units!

All R-410A mini-split units use a PVE oil (polyvinyl ether oil) that readily absorbs moisture from the atmosphere. To limit this "hygroscopic" action, the system should remain sealed whenever possible. If a system has been open to the atmosphere for more than 4 hours, the compressor oil must be replaced. Never break a vacuum with air and always change the driers when opening the system for component replacement. For specific handling concerns with PVE oil, contact your local Trane representative.

USE ONLY FACTORY RECOMMENDED - DAFNE HERMETIC OIL FV50S - for servicing these units.

***NOTICE:** Models 16 SEER 4TX1618A, 4TYK1618A and 4TXK1624A, 4TYK1624A (18K y 24K) use RB68EB POE Oil as indicated in page 9 graphic.

Important!

Environmental concerns

Scientific research has shown that certain man-made chemicals can affect earth's naturally occurring stratospheric ozone layer when released to the atmosphere. In particular, several of the identified chemicals that may affect the ozone layer are refrigerants that contain chlorofluorocarbons (CFC) and those containing hydrochlorofluorocarbons (HCFC). Not all refrigerants containing these compounds have the same potential impact on the environment. The company advocates the responsible handling of all refrigerants, including industrial replacements for CFCs such as HCFC and HFC.

Responsible refrigerant practices

Trane believes that responsible refrigerant practices are important to the environment, our customers, and the air conditioning industry. All technicians who handle refrigerants must be certified. The Federal Clean Act (Section 608) sets forth the requirements for handling, reclaiming, recovering and recycling of certain refrigerants and the equipment that is used in these service procedures. Furthermore, some states or municipalities may have additional requirements that must also be adhered to for responsible management of refrigerants. Know the applicable laws and follow them.

Content

Security cautions	5
Pre-installation list	6
Typical installation.....	7
Names and functionality of each part	7
Required clearances.....	8
Requirements for connecting lines	9
Warnings for refrigerant lines	10
Nitrogen purge during brazing	10
Installation location	11
Indoor unit installation.....	12
Mounting location	12
Hole boring for piping installation	13
Indoor unit refrigerant piping	13
Condensate piping installation.....	15
Indoor unit wiring	15
Piping and wiring bundling.....	17
Indoor unit hanging.....	17
Outdoor unit installation.....	18
Condensate draining	18
Refrigerant piping installation	19
Piping flaring and bending procedure.....	19
Outdoor unit refrigerant piping.....	20
Piping joints insulation	20
Piping requirements.....	21
Vacuum and refrigerant leak detection	22
Wiring warnings.....	23
Outdoor wiring connections.....	23
Stranded wiring connections	24
Electrical connections.....	25
Wiring specifications.....	26
Grounding.....	26
Controller installation	26
Lista verificadora de la instalación.....	27
Prueba de operación	27
Refrigerant system diagrams.....	28
Wiring diagrams.....	29
Unit dimensions	32
Common error codes.....	36
Emergency operation	36
Trouble shooting	37
Indoor unit maintenance	38
General maintenance	39

Instructive Annex

The device must not be used by people (including children) with physical, sensory or mentally impaired, or lacking experience or knowledge, unless they receive supervision or training. Children should be supervised so they do not play with the device. A circuit breaker or switch must be installed that disconnects all power poles with a separation of the poles of 3 mm. The appliance must be installed in accordance with national regulations for electrical installations. The device is accessible to the general public. If you connect the appliance to a fixed power supply wiring, also install a surge protector of voltage and use a main switch and/ or a TYPE G power fuse that has a capacity of 1.5 times the maximum current of the unit.



Wall Unit

Security cautions

Warnings and cautions

Warnings are provided to alert installing contractors about potential hazards that could result in personal injury or death, while cautions are designed to alert personnel about conditions that could result in minor injury and equipment damage.

Your personal safety and the proper operation of this machine depend upon the strict observance of these precautions.

 WARNING	Indicates a potentially hazardous situation which, if not avoided, could lead to death or serious injury.
 CAUTION	Indicates a potentially hazardous situation which, if not avoided, could result in minor or moderate injuries. It may also be used to alert against unsafe practices.
 WARNING	
1. The installation should correspond to the distributor or to another authorized professional. Inappropriate installation could provoke water leaks, electric shock or fire.	
2. Install the unit following instructions contained in this manual. An incomplete installation could provoke water leaks, electric shock or fire.	
3. Verify that parts used in the installation are those provided or specified. The use of other parts could perhaps not adjust appropriately and lead to water leaks, electric shock or fire.	
4. Install the unit on a solid base capable of supporting the weight of same. Should the unit fall due to inadequate supporting base or incomplete installation, it could lead to personal injury or property damage.	
5. Electrical installation should conform to the installation manual and the appropriate NEC codes and local/state codes. Insufficient capacity or incomplete electrical installation could lead to electric shock or fire.	
6. Ascertain the use of an independent power source. Never use a power source that is shared with another piece of equipment or device.	
7. For wiring, use wiring of sufficient length to reach the required distance without the need of splicing. Do not use extension cables. Do not add additional charges to the power supply. Employ an independent power circuit. (If these instructions are not followed, it could cause abnormal overheating, electric shock or fire.)	
8. Use the specified types of wiring for electrical connections between the indoor and outdoor units. Properly adjust the interconnecting cables in order to avoid external stress upon their terminal box. Incomplete connection or adjustment jobs could cause overheating of the junction box and provoke fire.	
9. When ending the tasks of interconnection and power supply wiring, place the wiring appropriately to avoid unwanted pressure over the electric panels and covers. Install all corresponding panels over the wiring. Incomplete installation could cause overheating of the junction box, electric shock or fire.	
10. Once the installation has ended, verify the absence of refrigerant leaks.	
11. If a refrigerant leak has been detected during the installation process, ventilate the room. (Refrigerant produces a toxic gas if it were to be exposed to flames).	
12. During the pumpdown process, stop the compressor before removing the refrigerant lines. If the compressor continues to run and the stop valve is in open position during pumpdown, air will be suctioned during the removal of the refrigerant lines, producing abnormal pressure on the refrigerant cycle, which in turn could lead to breakage and personal injury.	

- | |
|--|
| <p>14. During installation, tighten the refrigerant piping before starting the compressor. If the compressor is not connected and the stop valve is open during pumpdown, air will be suctioned while removing the refrigerant piping, producing abnormal pressure on the refrigerant cycle, which in turn could lead to breakage and personal injury.</p> |
| <p>15. Be sure to establish proper wire grounding. Do not ground the unit to any supply tube, arrestor or telephone grounding. An incomplete grounding could lead to electric shock or fire. Incomplete grounding could lead to electric shock or fire. An overcurrent condition due to thunder or other sources could damage the air conditioning unit.</p> |
| <p>16. If the electric supply cable is damaged, it must be replaced by the manufacturer, the service technician, or by qualified personnel in order to avoid risks of electric shock or fire during said replacement.</p> |

 CAUTION
--

- | |
|--|
| <p>1. Do not install the air conditioning unit in a place where it could be exposed to flammable gas leaks. Gas leakage and its accumulation around the unit could lead to fire.</p> |
| <p>2. Once the installation has been completed, verify the absence of refrigerant leaks.</p> |
| <p>3. This equipment should not be handled by inexperienced and unknowledgeable persons, unless they are duly supervised and instructed regarding the use of the equipment by a person responsible for their safety.</p> |
| <p>4. Children should be supervised to ensure they cannot play around or with the air conditioning unit.</p> |

NOTICE

- | |
|--|
| <p>1. Configure the drain piping following instructions found in this manual. Inadequate drain piping could bring on flooding and damages by water.</p> |
| <p>2. With the use of a torque wrench, tighten the flare nut according to the method specified in this manual. Overtightening the flare nut could provoke breakage that would lead to refrigerant leaks.</p> |

Pre-installation list

1. Inspect each unit after removing all packing material.
2. Verify that no damage is visible on the unit(s).
3. Verify that model numbers comply with those appearing in the order.
4. Verify data on the identification plate to ensure electric requirements are applicable.
5. Review base foundations to ensure that same will be able to support the weight of the unit.
6. Review and confirm that diameters of the interconnecting tubing will comply with recommendations found in the installation manual.
7. Before their connection, review electric line requirements to ensure that the appropriate wiring has been selected.
8. Verify that the indoor unit shows the proper nitrogen pressure reading (these always ship from the factory with a nitrogen charge to ensure waterproofing). Therefore, when removing "closing" valves from the liquid and gas lines, you should be able to hear nitrogen escaping from the unit, which will confirm that pre-charge has been maintained.

Wall Unit

Clearances required

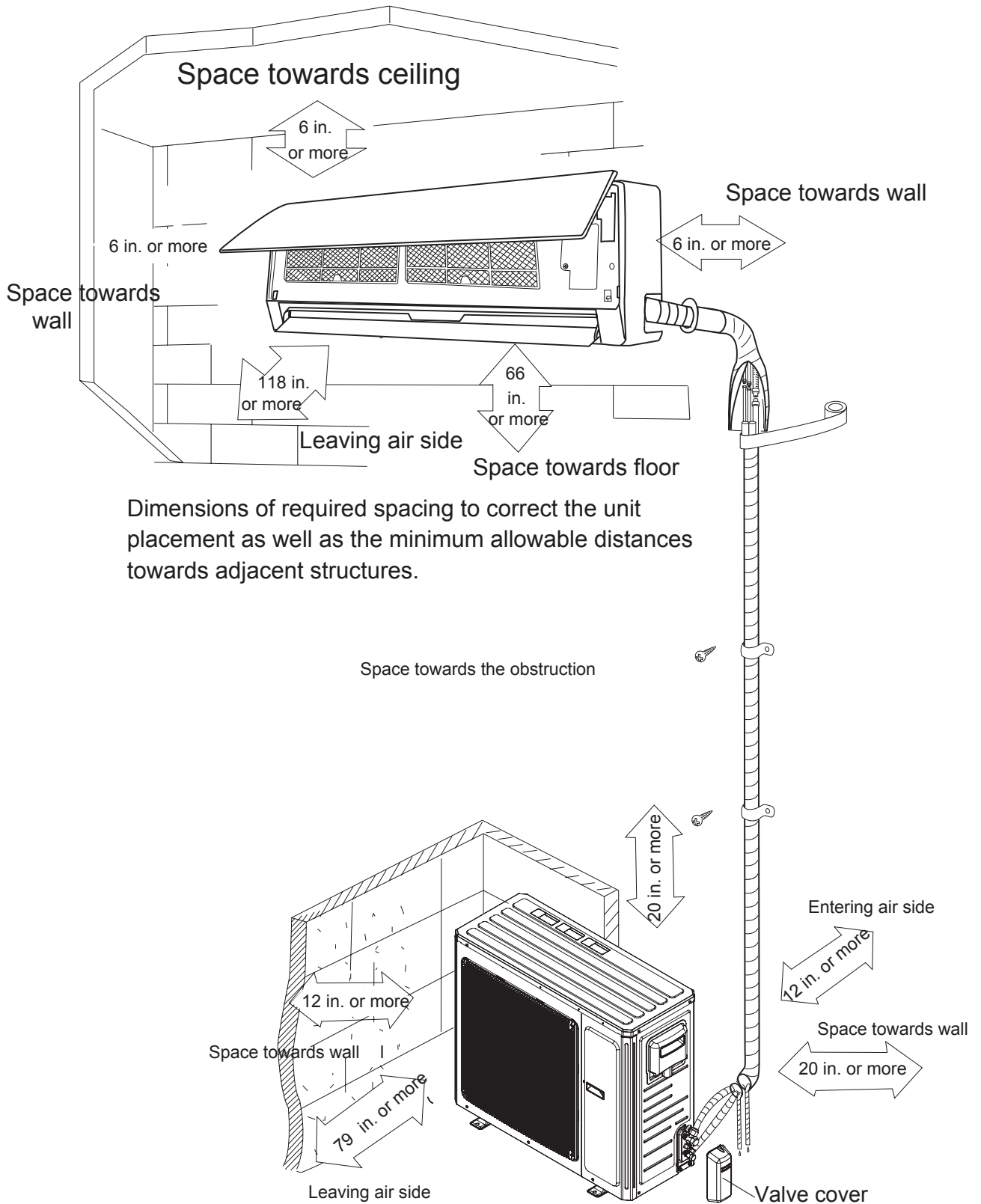

Dimensions of required spacing to correct the unit placement as well as the minimum allowable distances towards adjacent structures.

NOTE:

Maximum height recommended from the floor to the lower part of the indoor unit is of 11.5 ft. (3.5 m)

Connection piping requirements

NOTICE

Maximum length of connecting piping is shown in the following table. While placing the units confirm that the distance in between them exceeds the maximum length of connection piping.

Heat Pump		4TXK2309	4TXK2312	4TXK2318	4TXK2324	4TXK2330	4TXK2336
		4MXW2309	4MXW2312	4MXW2318	4MXW2324	4MXW2330	4MXW2336
Refrigerant charge (oz.)		45.9	47.6	56.44	77.6	84.66	91.71
Standard length m (ft)		7.5 (25)	7.5 (25)	7.5 (25)	7.5 (25)	7.5 (25)	7.5 (25)
Additional refrigerant charge (oz/ft) for larger length of piping as compared to standard piping		0.2	0.2	0.2	0.5	0.5	0.5
Outside diameter	Liquid pipe mm (in)	Φ 6.0 (1/4")	Φ 6.0 (1/4")	Φ 6.0 (1/4")	Φ 6.0 (1/4")	Φ 6.0 (1/4")	Φ 6.0 (1/4")
	Gas pipe mm (in)	Φ 9.52 (3/8")	Φ 12 (1/2")	Φ 16 (5/8")	Φ 16 (5/8")	Φ 16 (5/8")	Φ 16 (5/8")
Maximum distance	Height m (ft)	10 (33)	10 (33)	10 (33)	10 (33)	10 (33)	10 (33)
	Length m (ft)	15 (49)	20 (66)	25 (82)	25 (82)	30 (98)	30 (98)
Pipe minimum length m (ft)		3 (10)	3 (10)	3 (10)	3 (10)	3 (10)	3 (10)
Compressor oil used		DAPHNE FVC50K	DAPHNE FVC50K	RB68EP	RB68EP	PVE	FV50S

Cooling only		4TYK2309	4TYK2312	4TYK2318	4TYK2324	4TYK2330	4TYK2336
		4MYW2309	4MYW2312	4MYW2318	4MYW2324	4MYW2330	4MYW2336
Refrigerant charge (oz.)		45.9	47.6	56.44	81.1	84.66	84.66
Standard length m (ft)		7.5 (25)	7.5 (25)	7.5 (25)	7.5 (25)	7.5 (25)	7.5 (25)
Additional refrigerant charge (oz/ft) for larger length of piping as compared to standard piping		0.2	0.2	0.2	0.2	0.2	0.2
Outside diameter	Liquid pipe mm (in)	Φ 6.0 (1/4")	Φ 6.0 (1/4")	Φ 6.0 (1/4")	Φ 6.0 (1/4")	Φ 6.0 (1/4")	Φ 6.0 (1/4")
	Gas pipe mm (in)	Φ 9.52 (3/8")	Φ 12 (1/2")	Φ 16 (5/8")	Φ 16 (5/8")	Φ 16 (5/8")	Φ 16 (5/8")
Maximum distance	Height m (ft)	10 (33)	10 (33)	10 (33)	10 (33)	10 (33)	10 (33)
	Length m (ft)	15 (49)	20 (66)	25 (82)	25 (82)	30 (98)	30 (98)
Pipe minimum length m (ft)		3 (10)	3 (10)	3 (10)	3 (10)	3 (10)	3 (10)
Compressor oil used		DAPHNE FVC50K	FVC68D/RB68EP	RB68EP	RB68EP	PVE	FV50S

NOTES:

1. Connecting piping must be covered with waterproof insulating material.
2. Tubing thickness 0.5-1.0 mm (0.02-0.04 in): bearing pressure 3.0 MPa
3. Shorter lengths of connecting tubing produce higher thermal efficiency and therefore it is preferable to reduce connection tubing lengths whenever possible.
4. See oil trap instructions on page 21 for specific requirements when there exists a height difference superior to 20 feet between the indoor unit and the outdoor unit.

Operating ranges

Operating range cooling only	Outdoor temperature	0 - 115°F (-18.0 - 46°C)
Operating range heat pump	Outdoor temperature	5°F - 75°F (-15.0 - 24°C)

Wall Unit

Warnings for refrigerant piping



Danger of explosion and lethal gases!

Failure to follow safety measures in the handling of refrigerant, could lead to death or to serious injury. Never braze or solder on refrigerant lines or on unit components which are found above atmospheric pressure or in the presence of refrigerant. Always remove refrigerant following guidelines established by EPA (Federal Clear Air Act) or by other appropriate state or local codes. After removing refrigerant, use dry nitrogen to return the system to atmospheric pressure before opening the system for repairs. The mixture of refrigerants and air under pressure may convert into fuel element in the presence of an ignition source which could lead to explosion. Excessive heat due to brazing with tin alloy, lead alloy or brazing in the presence of refrigerant vapors, could form highly toxic gases and extremely corrosive acid

NOTICE

Damage to system components!

Do not remove sealing caps to refrigerant connections and do not open service valves until you are ready to braze refrigerant lines to the connections. Excessive exposure to the atmosphere (>5 min.) could contaminate the system through entering humidity or dirt and consequently damage valve seals and promote icing on system components during the operation.

Nitrogen purge during soldering

NOTICE

Avoid damages to the unit!

Never solder connections to piping without having performed a nitrogen purge. Failure to follow this procedure could damage the unit and lead to loss of capacity and as a result reduce the degree of confidence on the unit in the long run.

While brazing refrigerant piping, perform a flush with dry nitrogen gas. Use a pressure regulator to maintain a flow of 0.03 CFM (0.05 m³/h) or more.

Nitrogen purging while brazing refrigerant pipes

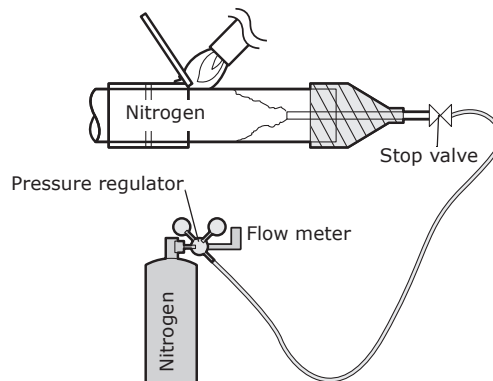

Location of installation

Indoor unit



WARNING

Proper support required!

The wall should have the appropriate structure to support the weight of the unit. Failure to do so could cause the unit to fall and could lead to death, serious injury, or damage to the equipment or on the property.

1. Avoid placing the indoor unit in a location which could obstruct the return or the supply of air.
2. Select a place that allows easy draining of water condensates and allows proper connection with the outdoor unit.
3. Install the indoor unit away from sources of heat, vapor, and flammable gas.
4. Verify that the installation of the unit complies with dimensions as shown on the installation diagram.
5. Ensure the availability of sufficient space to allow routine maintenance; the clearance between the lower part of the indoor unit and the floor should not be less than 66 inches.
6. The place of installment of the unit should be more than 3 feet away from other electronic appliances which may cause interference such as television sets, audio devices, etc.
7. Select a place that allows easy removal and replacement of air filters.

Outdoor unit



WARNING

1. Install the unit in a place that does not allow it to be pitched in excess of 5°.
2. If the location is subject to strong winds, said additional force should be considered to secure the unit firmly to the base.

1. Select a place in which noise and discharge air of the unit does not bother the neighbors.
2. Select a place with sufficient ventilation.
3. Ensure that incoming air and outgoing air are not blocked by some type of obstacle.
4. Select a place capable of supporting the weight and the vibration of the outdoor unit and where maintenance tasks can be performed with safety.
5. Select a place away from flammable gas and gas leaks.
6. Ensure that the outdoor unit installation complies with the recommended clearances shown in the corresponding diagram.
7. Place the outdoor unit away from bedroom windows.

NOTICE

The installation of the unit in one of the following locations could cause the malfunction of the equipment:

1. Places where oil is utilized (machine oil).
2. Coastal locations with high levels of salty air.
3. Places with high levels of sulphuric gas such as areas with thermal sources.
4. Places where high frequency waves are generated by radiocommunication equipment, soldering and medical equipment.
5. Other unusual places where unit operation could suffer alterations.

Installation of the indoor unit



WARNING

Dangerous service procedures!

Maintenance and troubleshooting recommended in this section of the manual could expose persons to electrical, mechanical and other potential safety dangers. Always refer to Warnings and Cautions provided in this manual. When possible and before servicing this unit, disconnect all electric power, including remote disconnects and discharge all energy storage devices such as capacitors. Follow proper lockout/tagout procedures to ensure that power cannot be inadvertently energized. When required to work on energized electrical components, make sure that the work is performed by an authorized and qualified technician or by a qualified person in the handling of energized electrical components. Failure to follow these safety recommendations could lead to death or serious injury.

Mounting location

1. Confirm the mounting location with the customer. For a safe installation, consider all security indications found on Page 11.
2. Place mounting frame on the wall and verify the appropriate levelling. Mark the spots to drill holes for the screws and ensure their placement will have the capacity to support the weight of the unit.
3. Drill holes on the marked spots. For additional safety, insert rawl plugs to provide for additional support.
4. Install the mounting frame using the concealed screws provided and verify their location. If a screw or rawl plug seems loose, select another spot on the frame to drill a hole in order to install safely.
5. Make sure the mounting frame is firmly installed and able to support 4 times the weight of the unit. Weight should be divided equally at each clamping spot.

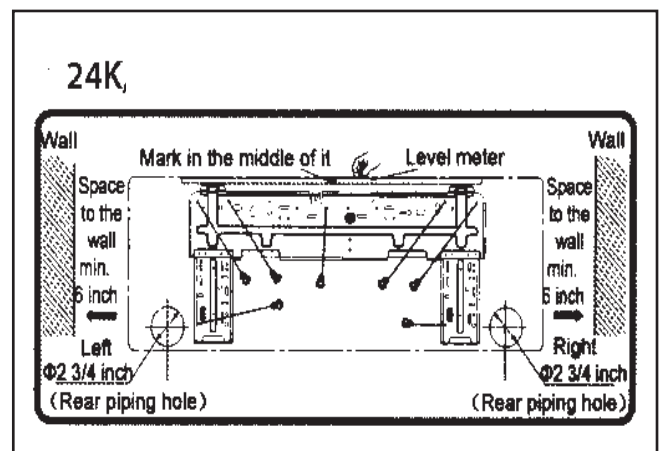
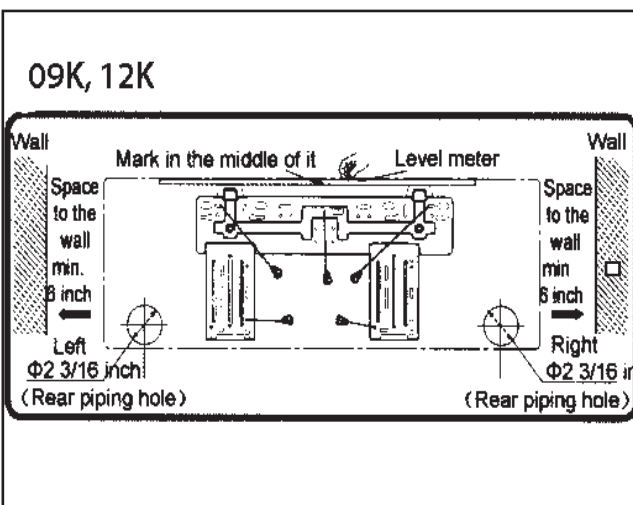

18K

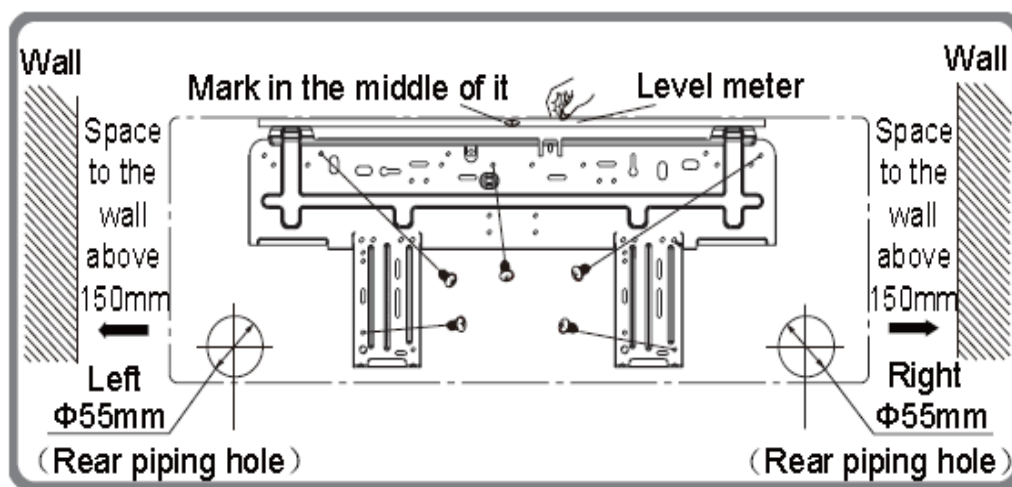

30K, 36K

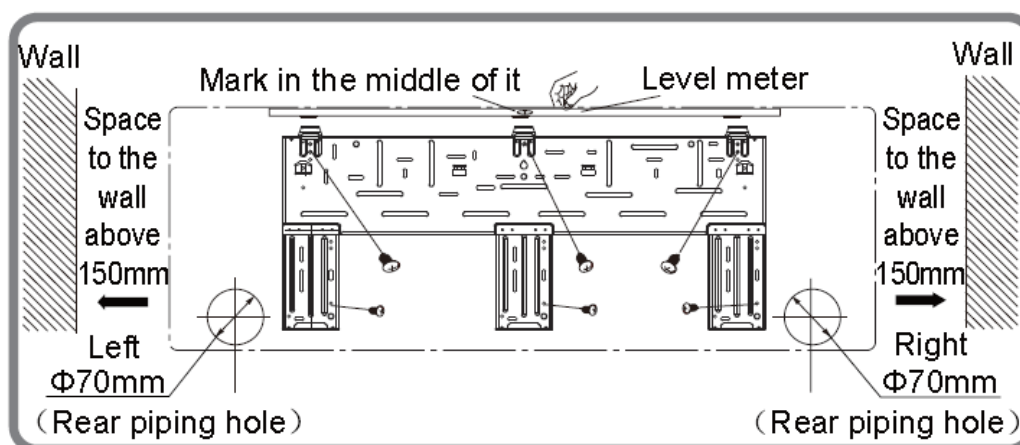

Wall Unit

Piping can be connected in right direction, right/rear direction, left direction, left/rear direction.

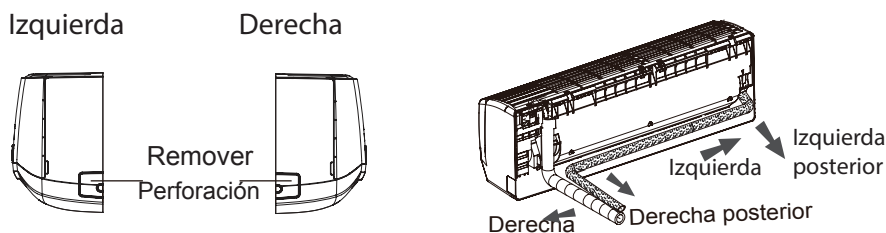

1. Once the position of the drain pipe has been selected, remove the corresponding perforation indication from the unit housing.
2. Select the position of the piping hole/orifice to be drilled in accordance with the position of the drain pipe selected for the application. The position of this pipe hole should be slightly smaller than that of the mounting frame on the wall.
3. Drill a hole of 2 3/16 inch or 2 3/4 inch (24K unit) diameter for the insertion of the selected outgoing pipe. In order to obtain efficient draining, the outgoing hole should be slightly pitched during drilling at a gradient of 5-10° (shown below).
4. Insert an insulating sleeve inside de hole/orifice in the wall to prevent damages to the connection piping and to the wiring that will pass through this drilled orifice.

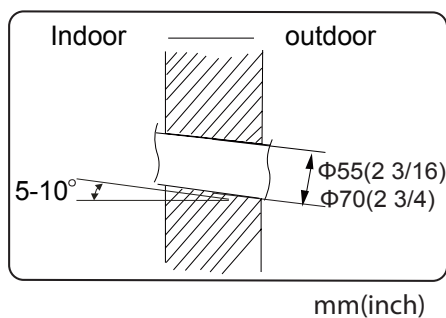

NOTICE

1. When an insulating sleeve is not utilized, it will then be necessary to drill a completely straight hole in the wall. If this hole is not straight and uniform, it could initiate water leaking through condensation as well as damages to the property.
2. If an insulating sleeve is not mounted in the orifice, the wiring between the indoor unit and the outdoor unit could suffer damage as a result of the loss of electric current to the grounding cables.

Refrigerant piping in the indoor unit

Remove covers and caps from the piping.

NOTICE

1. Be sure to connect piping appropriately to the port in the indoor unit. If it is not centered correctly, the flare nut will not be able to be tightened as it should. If tightening of the nut is forced, the fitting threads will be damaged.
2. Do not remove the flare nut until ready to connect the connection piping and avoid the entry of pollutants into the piping system.

1. To connect or remove pipes from the unit, always use a spanner wrench and a torque wrench.
2. For connecting, apply refrigerant oil to both sides - inner and outer - of the flare nut and proceed to tighten first with your fingers, and then with the use the torque wrench.
3. Refer to the table below before adjusting the nut to determine the appropriate torque. Overtightening could damage the nut and lead to leaking.
4. Examine the connecting tube to confirm the absence of leaking. Apply heat insulation to the liquid and gas lines.
5. Use sponge coating of medium size to insulate the gas tube joint.

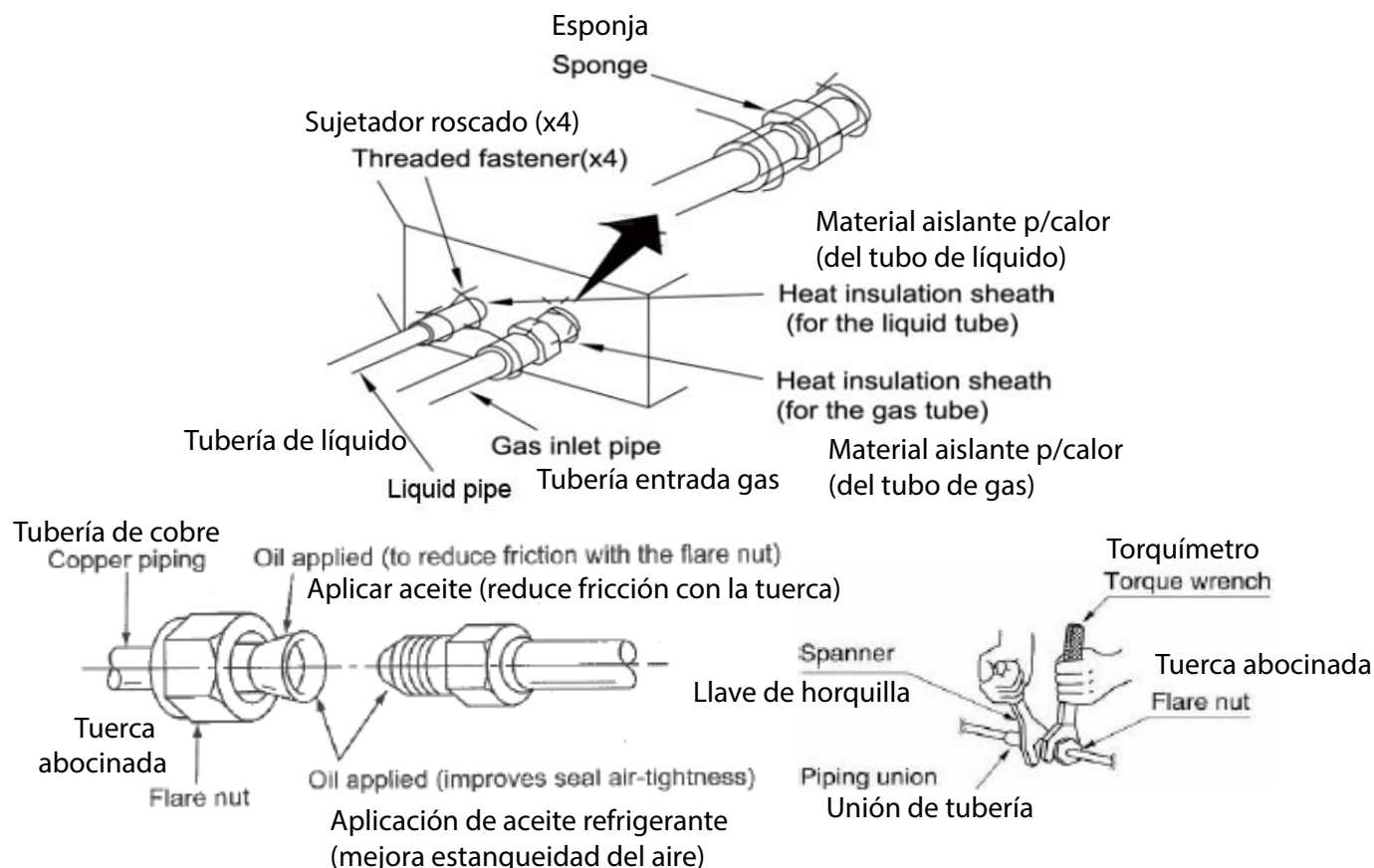

In. (mm)	Torque force
1/4 (6.35)	15 ~ 30 N•m / 20.3-40.7 (ft-lbf)
3/8 (9.52)	35 ~ 40 N•m / 40.7-54.2 (ft-lbf)
1/2 (12.7)	45 ~ 50 N•m / 61.0-67.8 (ft-lbf)
5/8 (15.9)	60 ~ 65 N•m / 81.3-88.1 (ft-lbf)
3/4 (19.05)	60 ~ 65 N•m / 94.9-101.7 (ft-lbf)

Wall Unit

Installation of condensate piping

NOTICE

Do not force or bend the drain hose and verify that the end of it is not placed in water. Otherwise it will cause leaking.

1. Connect the drain hose to the indoor unit's outgoing pipe (see Fig. A below).
2. Wrap the joint with tape (see Fig. B below).
3. Wrap the piping with insulation tape to avoid condensation (see Fig. C below).

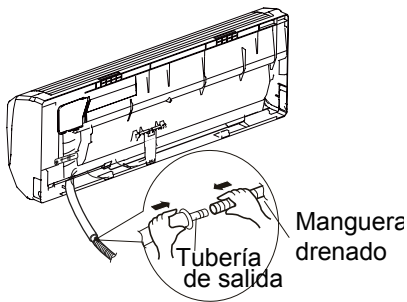

Fig. A

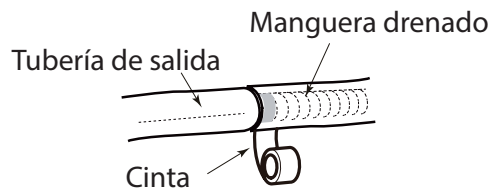

Fig. B

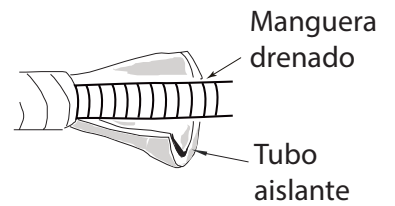

Fig. C

Indoor unit wiring

1. Open the front panel of the indoor unit, remove the screw of the wiring cover and remove cover (see Fig. D below).
2. Insert power connecting cable through the orifice for wiring at the rear of the indoor unit until it leaves through the front side of the unit (see Fig. E below).

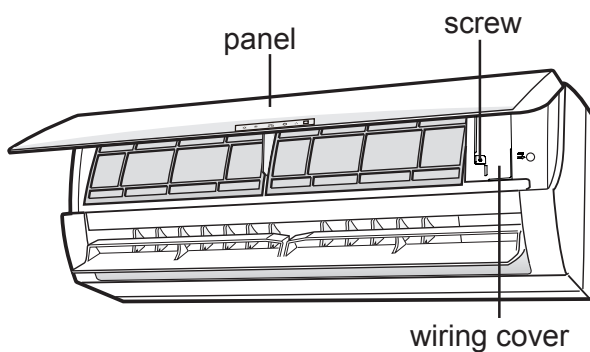

Fig. D

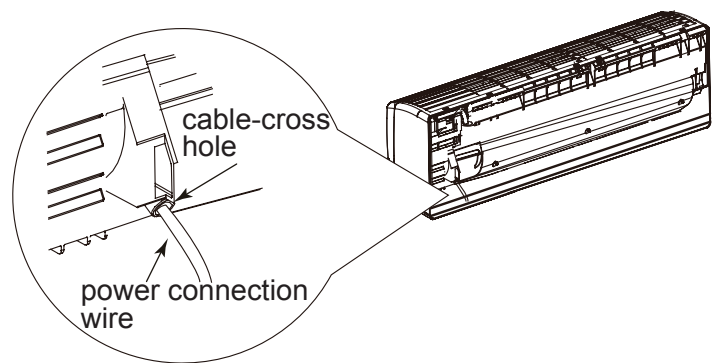
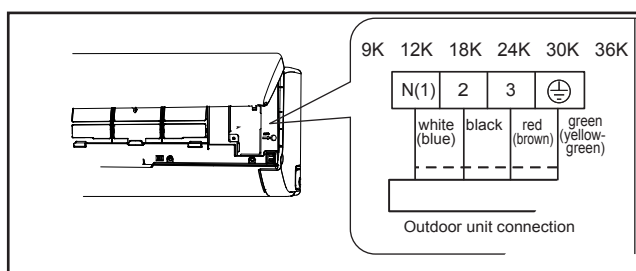

Fig. E

3. Remove the cable clamp and connect the power connection cable to the terminal strip following correct color coding. Tighten the screw; adjust the power cable using a cable fastener.
4. Place wiring cover back in its place on the unit and tighten the screw.
5. Close the front panel.

NOTE: When indoor unit is energized from the outdoor unit and, following local coding, it will be required to install a disconnect switch to an independent power supply circuit.

1. A primary disconnect switch for both indoor and outdoor units should be mounted on the outdoor unit. If local coding requires an independent disconnect switch on the indoor unit, then this primary disconnect switch should serve to break only those wires connected to terminals 1 and 3.
2. Before initiating any service and maintenance tasks, and in order to avoid electric shock or equipment damage, disconnect the system at the indoor unit.
3. Terminal strip 2, as a carrier of communication signals, should not be cut nor spliced.
4. Grounding cable must be connected directly from the outdoor unit to the indoor unit. In order to avoid communication errors, do not connect grounding cable to the terminal block from no other location point.



NOTE: Wiring diagrams in this catalogue are included only as reference. The manufacturer follows a continuous policy of product and data improvement and reserves the right to change designs and specifications without prior notice. Always consult unit's identification nameplate to verify actual requirements of the unit.

Wall Unit

Pipe and cable bundling

1. With the use of a band, wrap individually refrigerant piping with its insulation, the power cable, and the drain hose. See diagram below.
2. When preparing the bundle, reserve a portion of the drain hose and of the power cable to perform the installation. Reserve additional space to allow the drain hose to be separated from the power connections and from the outdoor unit piping.
3. Tie these wrappings together to form a tube bundle. See diagram.
4. Liquid and gas tubes must be wrapped separately at the end.
5. Whenever possible, maintain a separation between the power cable and the communication lines.

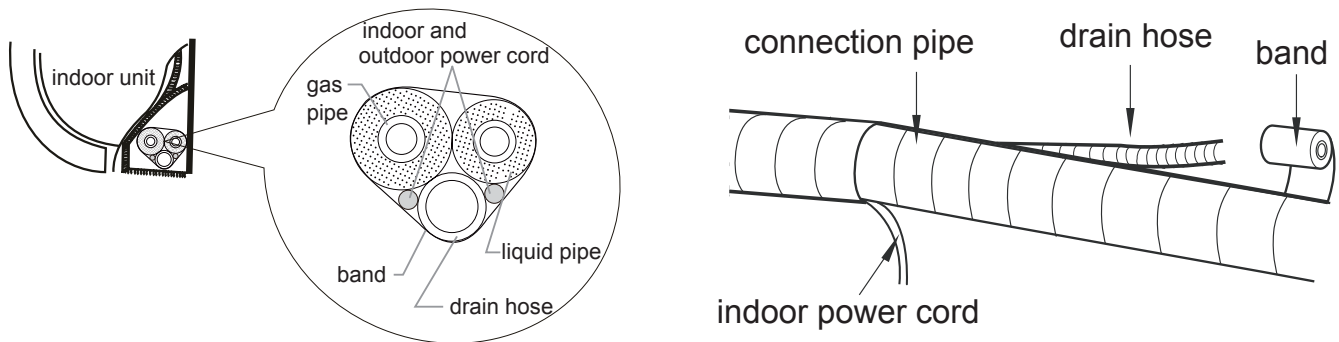

Suspensión de la unidad interior

1. Inserte el haz de tubos y cables dentro del casquillo de pared y dejar que pase hacia el exterior.
2. Suspenda la unidad interior sobre el marco de montaje en la pared.
3. Con el uso de material sellador, rellene los huecos entre la tubería y el orificio de pared o casquillo protector.
4. Asegure el haz de tubos con abrazaderas de montura.
5. Verifique que la unidad interior se encuentra fijada segura y correctamente en la pared.

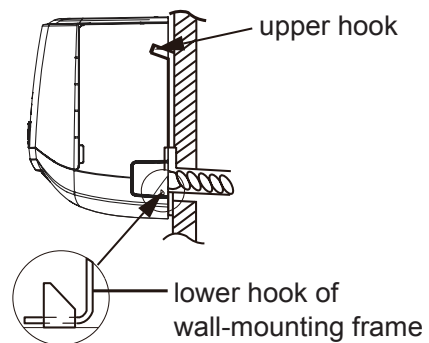
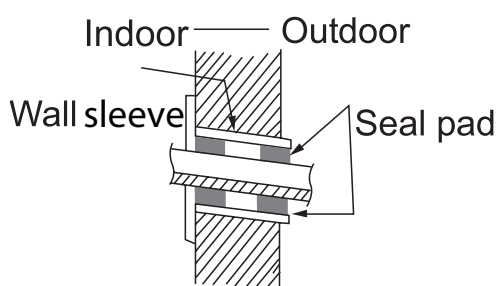

Outdoor unit installation



WARNING

1. Install the unit in a place that does not allow it to be pitched in excess of 5°.
2. If the location is subject to strong winds, said additional force should be considered to secure the unit firmly to the base.

When the outdoor unit is surrounded by walls and other obstructions, the installation space for the unit should not be less than the clearances indicated below. For efficient operation of the unit and, whenever possible, leave open spacing in three or four directions of peripheral construction.

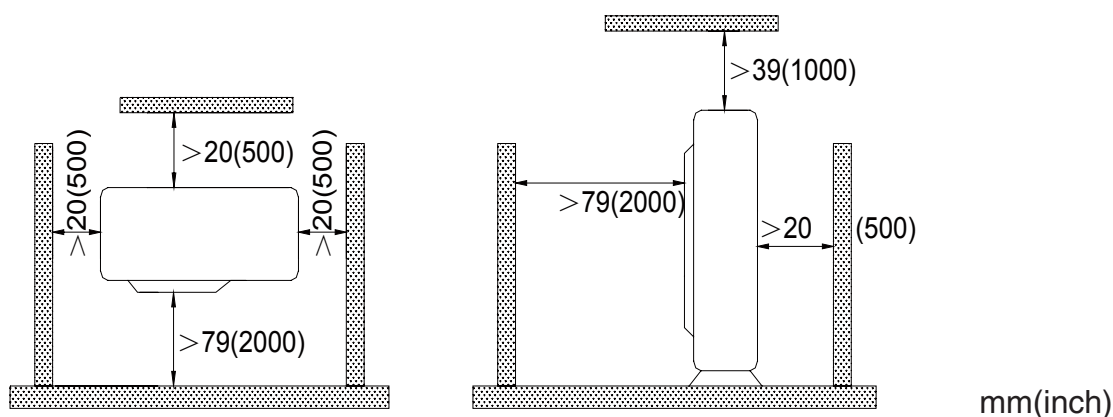

Select an installation area that provides easy access to the unit.

1. Verify that the place can support at least four times the weight of the unit.
2. Using expansion bolts, install the outdoor unit over the base of the selected area.
3. The unit should be installed at least 1 1/16 inches above the base to enable the installment of a connection for the drain line. (See image below).

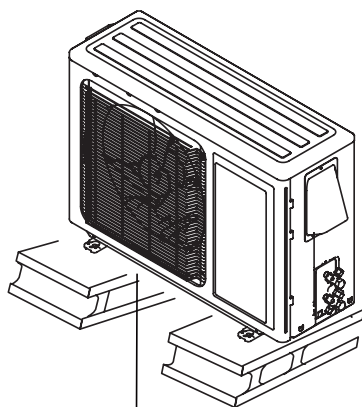

At least 1 1/6 inch clearance

Outdoor unit condensate handling

1. Installation of tubing for condensate draining is required for the outdoor unit's heating operation.
2. During the installation of the drain line, aside from the opening for the drain tube, all other openings must be sealed to prevent water leaks.
3. Insert the drain tube fitting inside the opening for the insertion of the drain tube located at the base of the unit; following, connect the drain tube to the coupling just performed.

Wall Unit

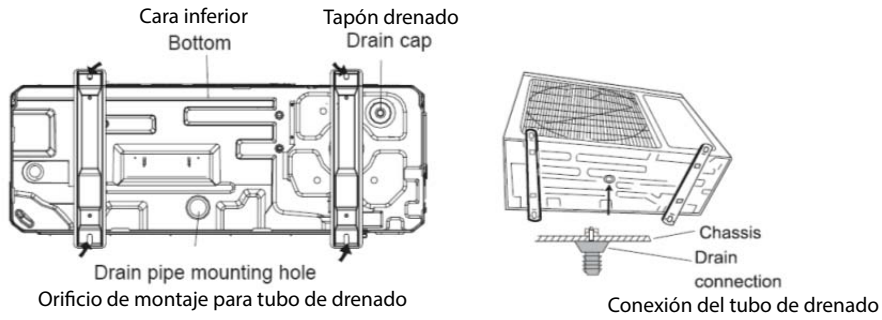

1. Place the outdoor unit on the supporting base.
2. Install the unit's support foot holes using bolts/screws as seen below.

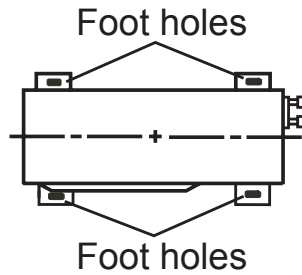

Refrigerant piping installation

Tube flaring

1. Hold the tube downwards to prevent debris from entering into the piping.
2. Cut the refrigerant tube using a tube cutter and remove all chips/burr.
3. Remove flare nuts from the outdoor unit shutoff valve, as well as those found inside the indoor unit's accessories bag and place the latter over the connecting tube as shown in the following diagram. Next, flare the refrigerant tube using a flare tool.
4. Verify that the flared part is equally distributed and that no fracturing is visible.

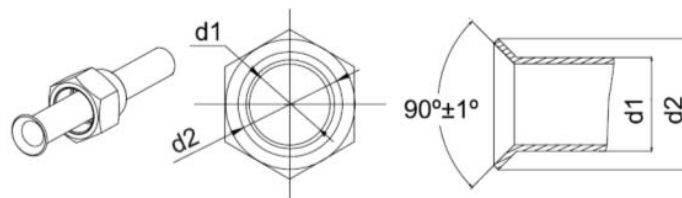

Tube bending

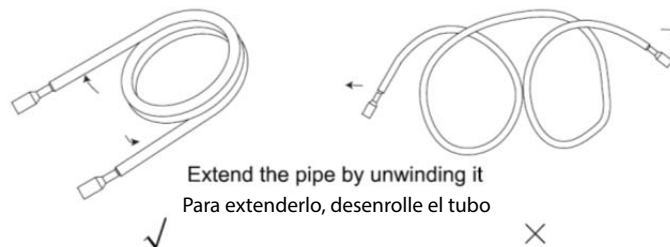

1. Tubes must be bent with the hands or with a tube bender for tighter flexion. Take care to avoid collapsing the tubes.
2. Do not flex tubes at an angle higher than 90°.
3. Repeated bending and straightening of tubes could damage the material and lead to refrigerant leaks. Do not bend or straighten tubes more than three times.

4. Do not bend piping when covered with insulation material. In this case, cut the insulation with a sharp cutter as is shown below and then proceed to mold the naked pipe. Make sure that insulation is placed back on the pipe and seal it using sealing tape.

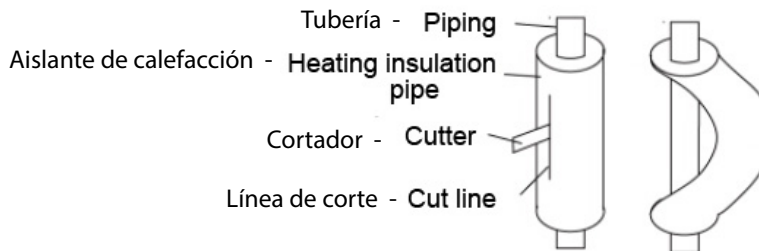

NOTICE

1. To prevent distortion and breaking of the pipe, avoid applying sharp bends. Flex tube applying a curve ratio of 6 inches (150 mm) or more.
2. Bending the tube repeatedly in the same place will cause the tube to break.

CAUTION

Make sure to connect the gas pipe after finishing the connection of the liquid pipe.

Indoor unit refrigerant piping

Tighten connecting pipe's flare nut at the valve coupling of the outdoor unit. Apply the same tightening method as employed at the indoor unit.

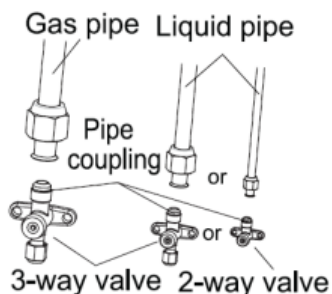

Insulation of the piping connections

1. Refrigerant pipe must be insulated with the appropriate insulating material and plastic tape in order to prevent condensation and water leaking.
2. Indoor unit connections must be wrapped with insulating material. Do not leave any uncovered gap on the indoor unit as shown in the image below.

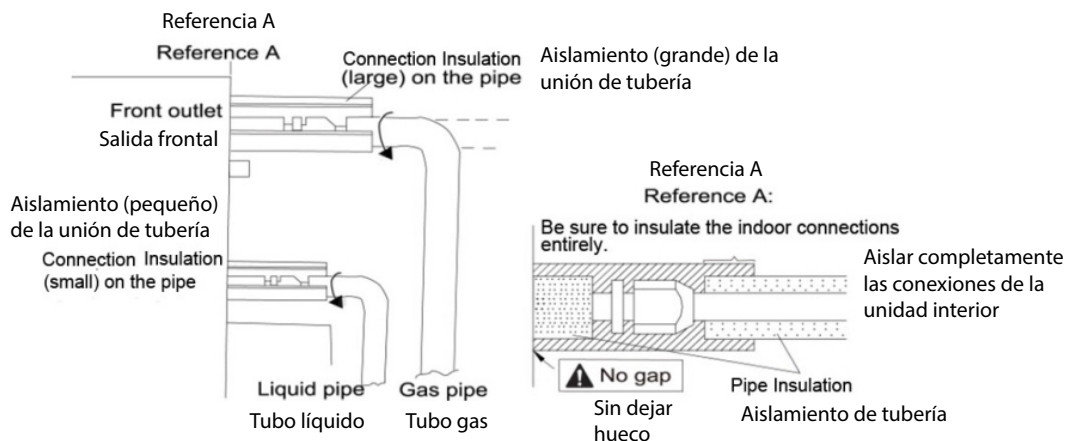

Wall Unit

Piping requirements

If the outdoor unit is installed below the indoor unit:

1. A drain pipe must be placed above the floor; the end of the drain pipe must not be placed in water.
2. The wrapping of the pipe must be applied from the bottom part towards the top; it should not be very tight to avoid compression of insulating material and to prevent a loss of efficiency.
3. All pipes are joined together to form a tube bundle which is then installed onto the wall using saddle brackets.
4. NOTE: Oil traps are required when the outdoor unit is installed below the indoor unit. An oil trap is required at each 33 ft. (10m) of vertical gas pipe length.

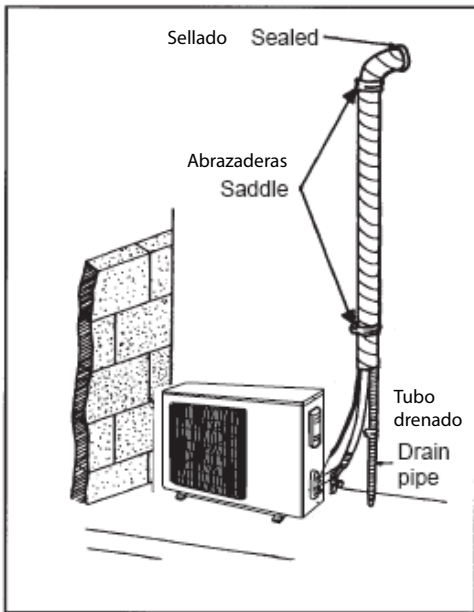

Outdoor unit installed below the indoor unit

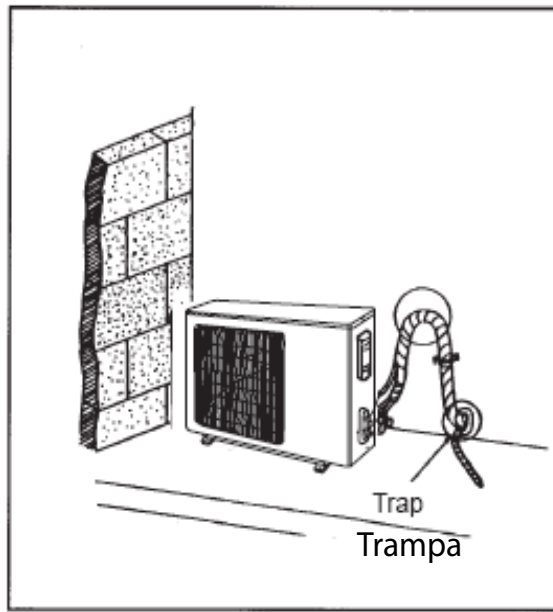

Outdoor unit installed above the indoor unit

If the outdoor unit is installed above the indoor unit:

1. Tape wrapping must be applied from the bottom part towards the top; it should not be very tight to avoid compression of insulating material and to prevent a loss of efficiency.
2. All pipes are to be joined together to form a tube bundle which must then be trapped to prevent backup water into the room.
3. Install the pipes onto the wall using saddle brackets.
4. NOTE: Oil traps are required when the outdoor unit is installed above the indoor unit. An oil trap is required at each 20 ft. (6m) of gas pipe vertical rise.

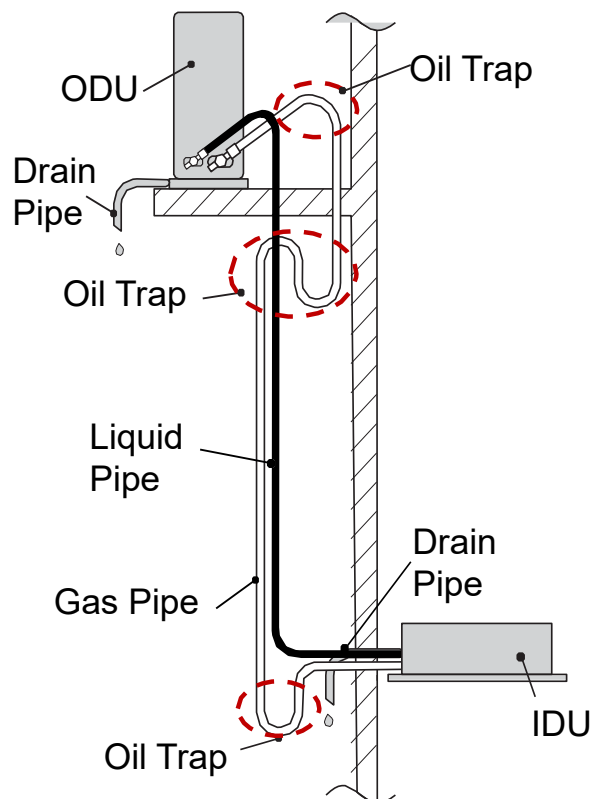

Vacuum and refrigerant leak

NOTICE

Do not purge air with refrigerant. Use a vacuum pump to purge the unit. No additional refrigerant exists in the outdoor unit to purge the air!

Vacuum action

1. Remove caps from the liquid valve, the gas valve, and from the service port.
2. Connect the hose, from the low pressure side of the manifold, to the service port of the unit's gas valve. Both gas and liquid valves must be kept closed to prevent any possible refrigerant leaks.
3. Connect the hose used for the pulldown, to the vacuum pump.
4. Continue with the purge until the gauge reaches a value not to exceed 350 microns; close the valve going towards the vacuum pump. Important: Do not open the service valves until the purge procedure has terminated and leak verification has been performed on the refrigerant lines and on the indoor coil.
5. Observe the vacuum gauge. Pulldown will be complete if the micron gauge does not rise above 500 microns in one (1) minute lapse.
6. Once the vacuum has ended, close the vacuum pump and the micro gauge and close all manifold valves.
7. Open the liquid valve slightly, in such a way, as to allow the flow of a small amount of refrigerant towards the connection in order to balance the pressure inside and outside of said piping, and thus avoiding the entry of air into the piping connection when removing the hose.
8. Place the caps back on the liquid valve, the gas valve, and the service port.

Leak detection

1. Using a leak detector, verify the presence of any leaks at all connection points.
2. If you do not have a detector at hand, use soapy water. Apply the soapy water on each joint and wait a few minutes. If bubbles appear, it will indicate a leak which must be immediately repaired.

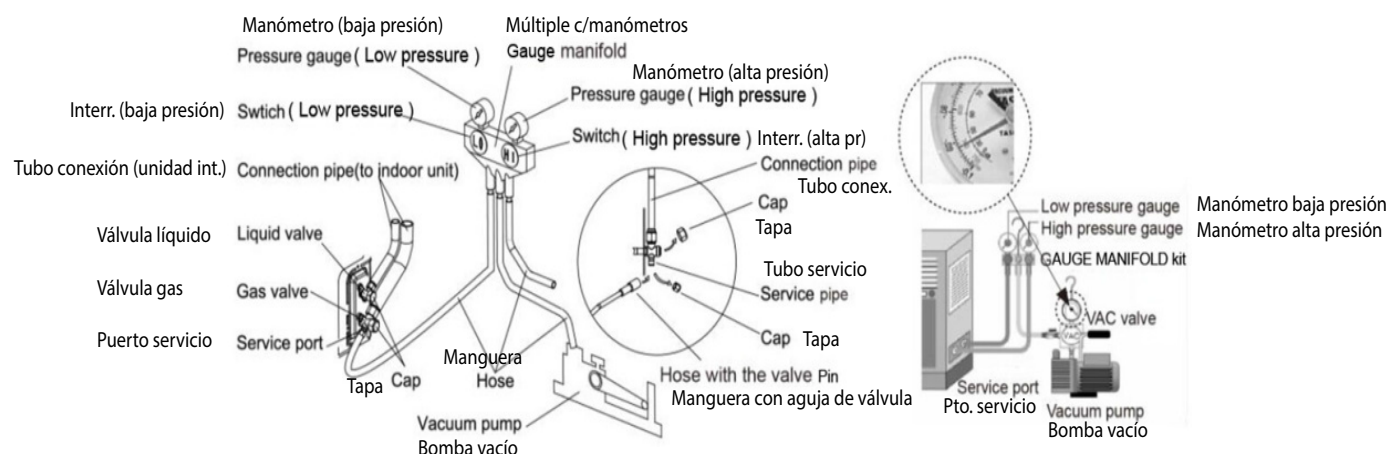

Wall Unit

Electrical connections



WARNING

1. Before obtaining access to terminals, disconnect all electrical supply circuits.
2. Failure to follow these instructions could lead to death or serious injury. Wiring installed improperly poses danger of fire and electrocution. In the case of high voltage connections, it is recommended to use flexible conduit when the transmission of vibrations could create noise problems to the structure of the building. To avoid such dangers, follow the wiring installation and grounding requirements stipulated by NEC (National Electric Code) as well as by local and state electric codes. All field wiring must be performed by qualified and authorized personnel.

Notes:

1. EACH unit must be installed with an individual power source. This power source must be sized correctly according to the capacity of the unit being installed.
2. Voltage classification is shown in the table appearing on page 25.
3. Before applying the energy, verify that voltage is found in the range of 187~252 V (for one-phase units voltage should be 208/230 V).
4. Always use a grounded terminal and install a proper receptacle to supply energy to the air conditioning unit. In the case of high voltage connections, it is recommendable to use flexible electric conduit when the transmission of vibrations could create noise problems to the structure of the building.

Outdoor unit wiring connections

1. Remove wiring fastener and connect the power cable and control cable terminals following their color coding.
2. Connect cables to the terminal strips and ensure proper adjustment.

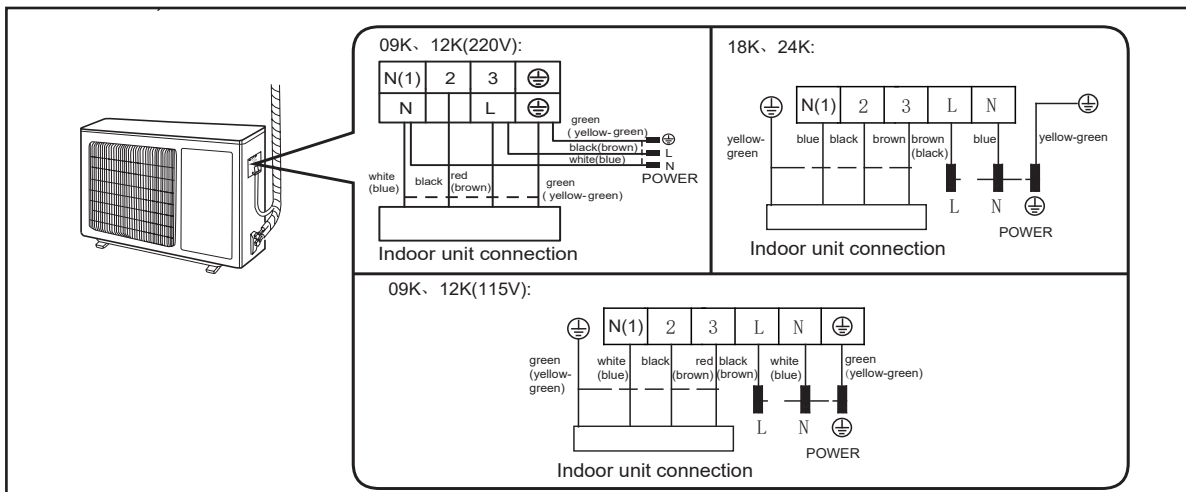

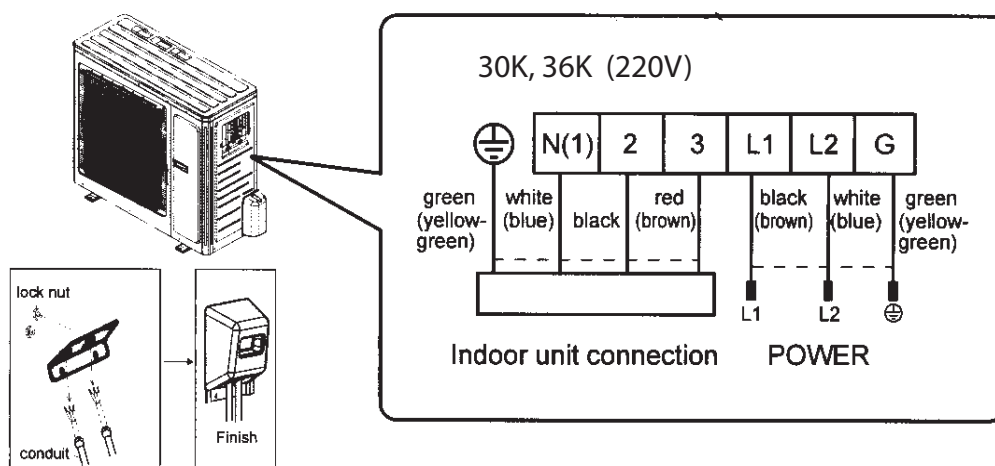

NOTE:Wiring diagrams in this catalogue are included only as reference. The manufacturer follows a continuous policy of product and data improvement and reserves the right to change designs and specifications without prior notice. Always consult unit's identification nameplate to verify actual requirements of the unit.

Wall Unit

Stranded wire connections

1. Cut the end of a cable with a cable cutter or similar; cut and remove about 10mm (3/8") of insulation.
2. Using a screwdriver, remove screw(s) from the terminal strip.
3. Using a round stranded wire holder, place a round terminal at each end of the naked wire.
4. Place the round terminal cable in its place and tighten the terminal screw using a screwdriver.
5. Secure the connection cable and the power cable with a cord clamp.
6. After directing the connection cable and the power cable through de isolation tube or conduit, secure the tube with the use of a cable fastener.

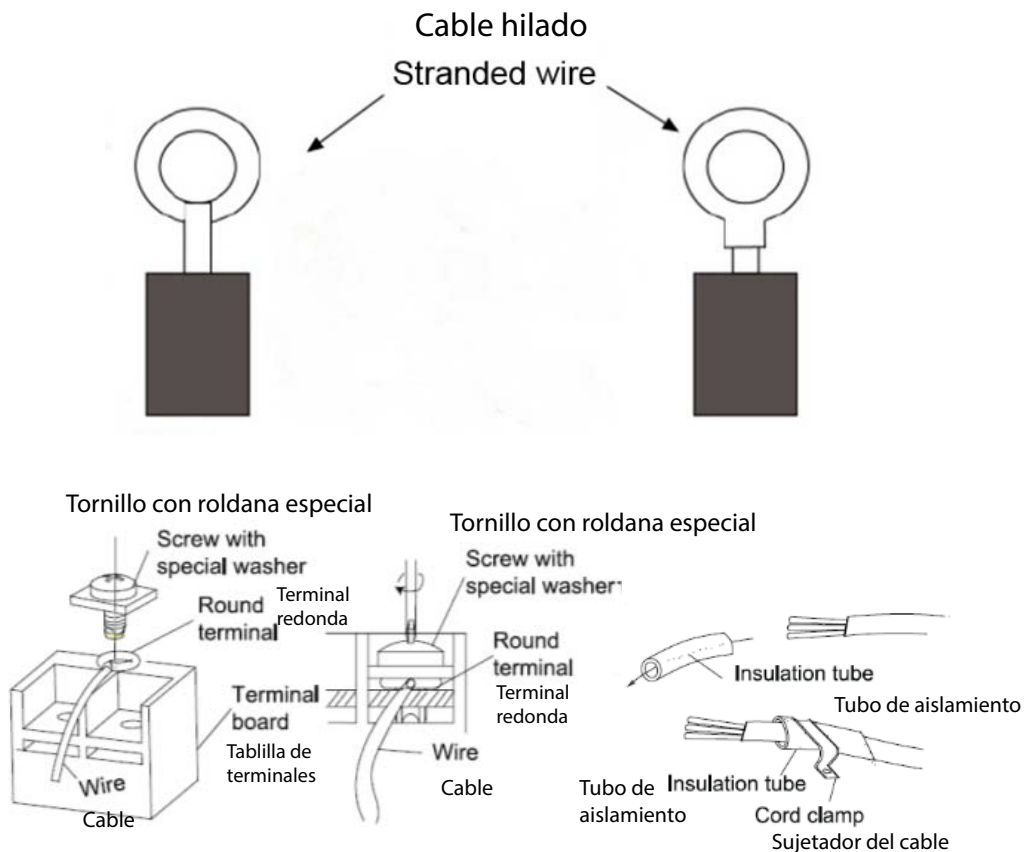

WARNING

1. Before starting the task, verify the absence of power supply to the indoor unit and the outdoor unit.
2. Inappropriate wiring installation in the field can lead to danger of fire and electrocution. Pay special attention to the unit wiring.
3. Cables should be firmly connected to the terminal block. Inappropriate installation could cause fire.
4. Always fasten the outside covering of wiring with cable fasteners. (If insulation is not fastened, it could lead to current leaks).
5. Always connect the cable to ground.

Note:

Always ascertain that numbers on the terminal block coincide with the colored cables corresponding to the indoor unit.

Electric connections

 CAUTION
Inappropriate operation could lead to personal injury or to property damage.
Make sure that wiring power classification follows indications from NEC, local codes, and MCA indicated on the unit's nameplate.

Electric requirements

Heat Pump Cooling only	4TXK2309A1 4TYK2309A1	4TXK2312A1 4TYK2312A1	4TXK2318A1 4TYK2318A1	4TXK2324A1 4TYK2324A1	4TXK2330A1 4TYK2330A1	4TXK2336A1 4TYK2336A1
Power supply	220V, 60Hz, 1 phase					

Cooling Only	4TYK2309A9	4TYK2312A9
Power Supply	115V, 60Hz, 1 Phase	

1. Always consult the unit's identification nameplate to verify MCA and MOP requirements.
2. Fuse is located in the main terminal board.
3. Since the indoor unit is energized from the outdoor unit and, depending upon local coding, it may be required to install a main disconnect switch to an independent power supply for the indoor unit.
4. Install an independent disconnect for the outdoor unit. Power supply, wiring and grounding of the equipment must comply with national, state and/or local coding. Power supply must comply with indications located on the unit's identification nameplate.
5. Inappropriate field wiring installation and grounding leads to dangers of fire and electrocution. In the case of high voltage connections, it is recommended to use flexible conduit when the transmission of vibrations could create noise problems to the structure of the building. To avoid such dangers, wiring installation and grounding requirements **MUST** comply with those stipulated by NEC (National Electric Code) as well as by local and state electric codes. All field wiring must be performed by qualified and authorized personnel. Failure to follow these requirements could lead to death or to serious injury.
6. Communication wiring between outdoor and indoor units must be of at least 14 AWG, stranded wiring, with a maximum absolute length of 230 ft. (70m). Shorter lines could provide a more robust communication between the indoor unit and the outdoor unit. Select the appropriate length in accordance with the installation's actual conditions. Communication cables **MUST NOT** be cut or spliced.
7. For wired controller: The communication distance between the main board and the wired controller can be of up to 65 ft. (Standard distance is of 25 ft.)

Note: When connecting the power cable, verify that voltage, frequency and cable phase is equatable to the voltage, frequency and phase indicated on the unit's identification nameplate. Otherwise, the compressor will not be able to perform appropriately and therefore lead to equipment damage.

Wall Unit

Cable specifications

Wiring between the indoor unit and the outdoor unit must be minimum 14 AWG, 4 core, stranded wiring, and voltage classification of minimum 600V.

Make sure to consult local and regional codes as well as those of NEC, to know the applicable requirements of the selected cable, as well as the requirements for cable raceway and waterproof conduit.

Power supply wiring should be installed following NEC, local and regional codes. Consult equipment requirements on the unit's identification nameplate.

Requirements for grounding

- Follow all local, state and NEC codes for grounding the unit.
- The air conditioning unit is classified as a Class 1 Appliance which must be grounded.
- The yellow-green cable of the air conditioner is the grounding cable, which must not be utilized for any other purpose, nor can it be cut, as it will lead to electric shock.
- Do not ground the unit to supply piping, arrester, or telephone grounding. Incomplete grounding could lead to electric shock or fire. A high current discharge from thunder or other sources could damage the air conditioning unit.

Controller installation

Refer to the controller installation manual for further information.

Verification after installation

Verify the following before testing the unit:

NO.	Points to verify	Possible problem
1	Were both indoor and outdoor units installed with proper safety?	Could fall, vibrate or make noise
2	Were tests for refrigerant leaks terminated?	Leaks that were not resolved could cause insufficient heating or cooling
3	Was piping properly insulated?	Lack of insulation could lead to condensation and water damages
4	Was the installation of condensate draining sufficient?	Inappropriate draining could lead to condensation and water damages
5	Does power supply voltage comply with indications on the unit's identification nameplate?	Incorrect power supply can create bad performance and lead to danger of fire or electrocution
6	Was electric wiring installed correctly as well as that of the drain piping?	Inappropriate wiring and draining could create bad performance and lead to danger of fire or electrocution as well as to unit and property damages due to water
7	Was the unit grounded properly?	Inappropriate grounding could cause bad performance, fire or electrocution
8	Does the power cable comply with unit requirements?	Inappropriate wiring can cause bad performance, fire or electrocution
9	Are there obstructions close to air entries and outlets for both indoor and outdoor units?	Inappropriate ventilation and air flow will lead to insufficient cooling or heating as well as possible freezing and condensate problems for the indoor unit
10	Has dust and debris been removed from the installation site?	Excessive dust and debris in and around the units can lead to bad performance and damage to the units
11	Are the gas and liquid valves of the connecting tubes completely open?	Restricted refrigerant flow can cause insufficient heating or cooling

Operation test:

1. Energize the units.
2. Using the remote control, press ON/OFF button to initiate the operation.
3. Press the MODE button to select and test each option for normal operation. Cycle through all functions: AUTO, COOL, DRY, FAN and HEAT.
4. Note: If ambient temperature is below 61°F (16°C) the unit will be unable to operate in the cooling mode.
5. Check with the customer all basic operating, maintenance and error detection functions.

Wall Unit

Refrigerant system diagram

Cooling only models

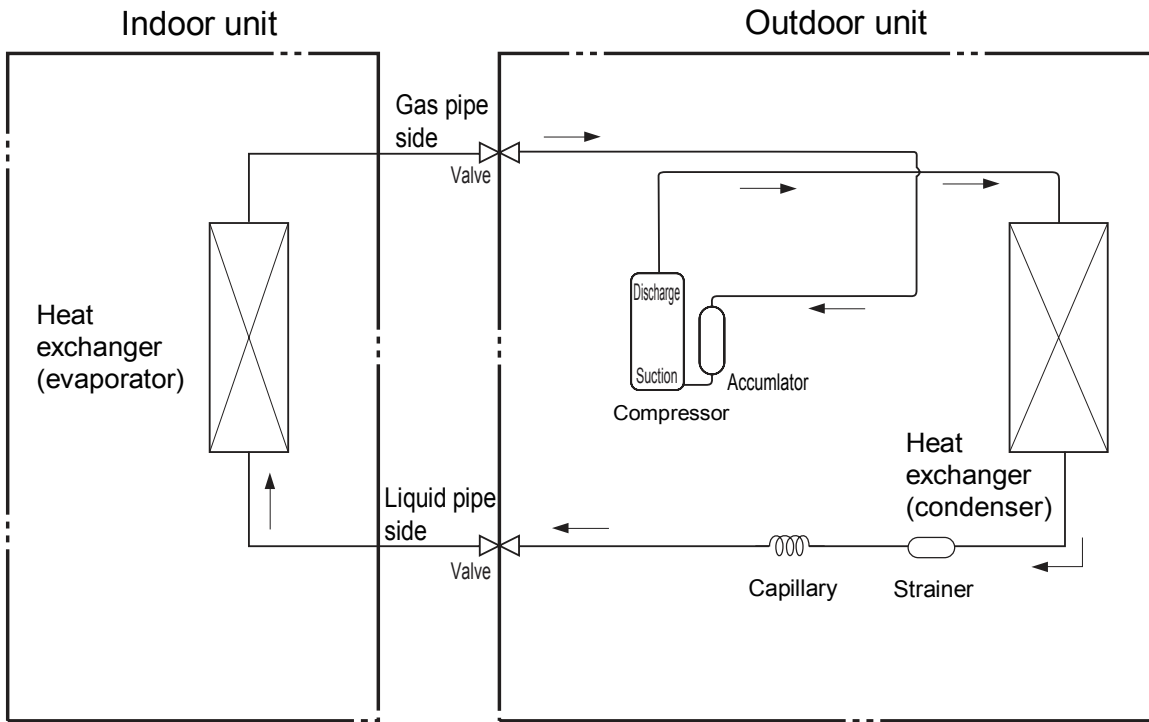

Heat pump models

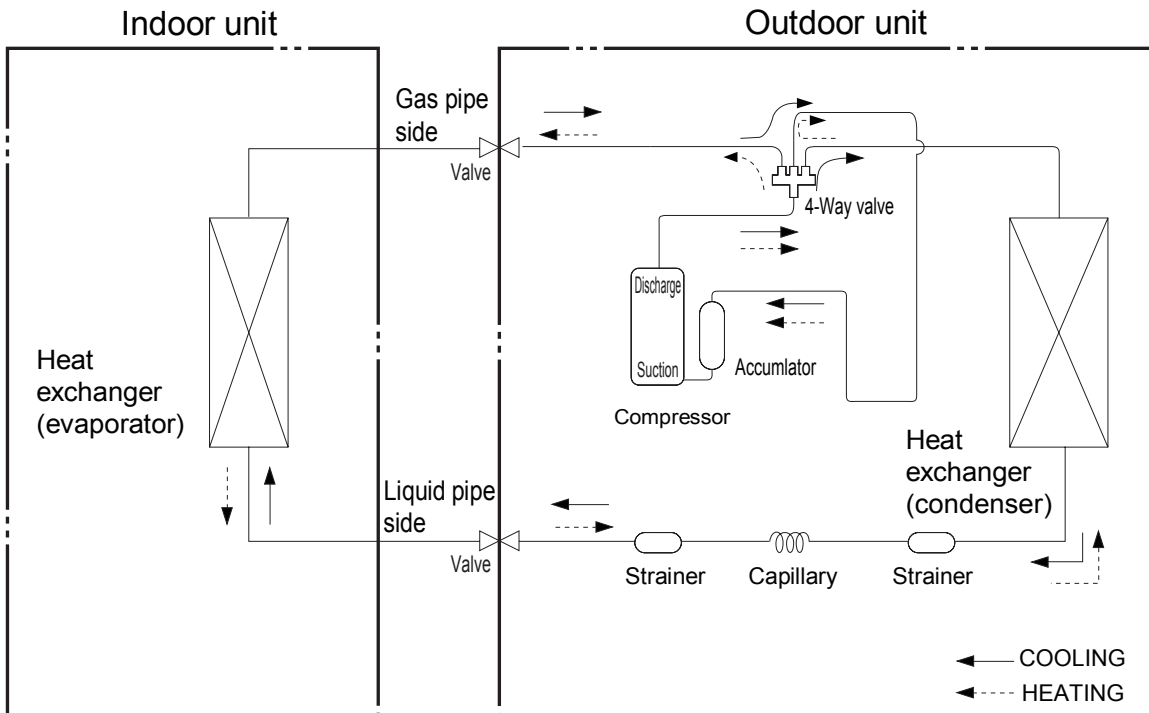

Connection pipe specification:
 Liquid pipe: 1/4" inch (all models)
 Gas pipe: 3/8" (for 9-12K)
 Gas pipe: 1/2" (for 18K)
 Gas pipe: 5/8" (for 24K)

Wiring diagrams

Color code

Symbol	Symbol Color	Symbol	Symbol Color	Symbol	Name
WH	White	GN	Green	CAP	Jumper Cap
YE	Yellow	BN	Brown	COMP	Compressor
RD	Red	BU	Blue		Grounding Wire
YEGN	Yellow/Green	BK	Black	/	/
VT	Violet	OG	Orange	/	/

Note: The JUMPER CAP (bridge) is used to determine the fan speed and the sweep action angle of the horizontal louver for this model. The unit will not operate without the appropriate bridge (jumper cap). When replacing the boards, this bridge (jumper cap) must be transferred to the new board.

Indoor unit - Cooling only - 4MYW2309A1 - 4MYW2309A9 - 4MYW2312A9

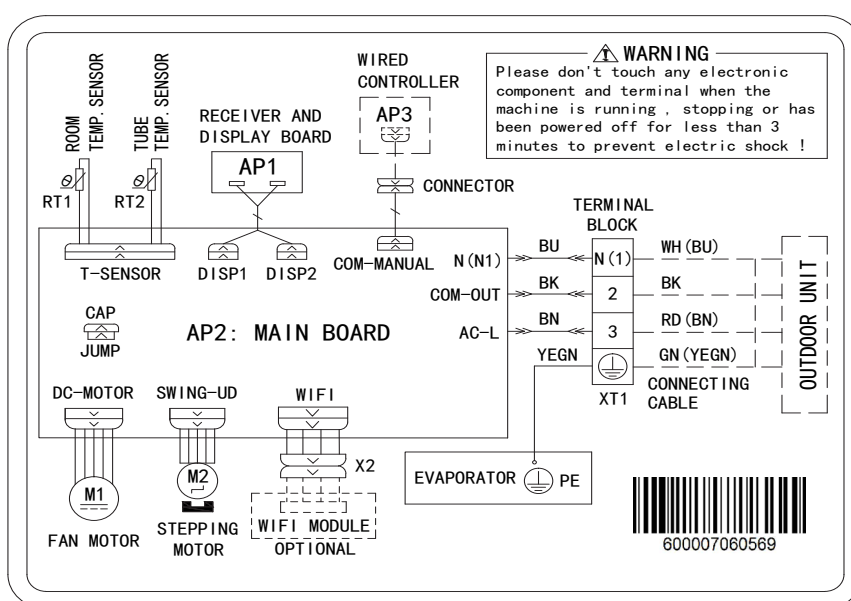

Indoor unit - Cooling only - 4MYW2312A1

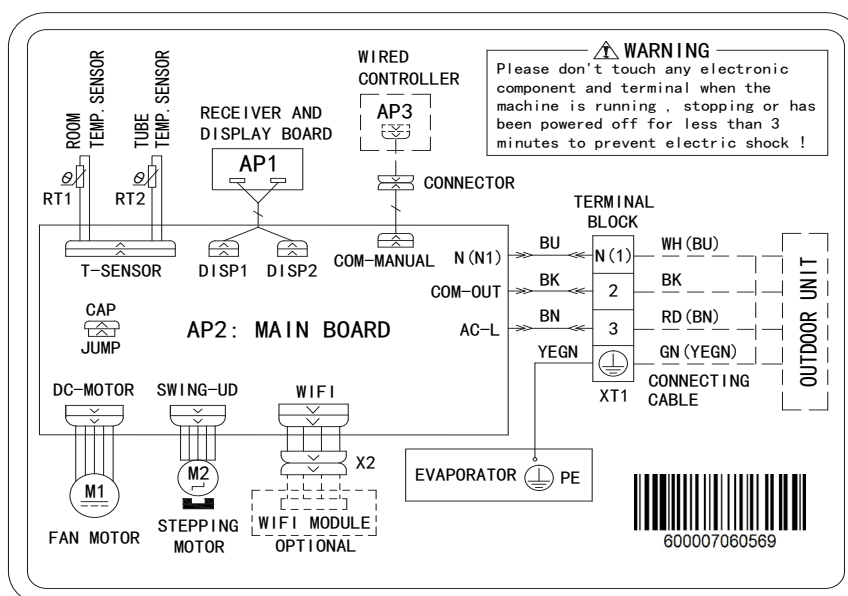

Indoor unit - Heat pump - 4MXW2309A1 - 4MXW2312A1

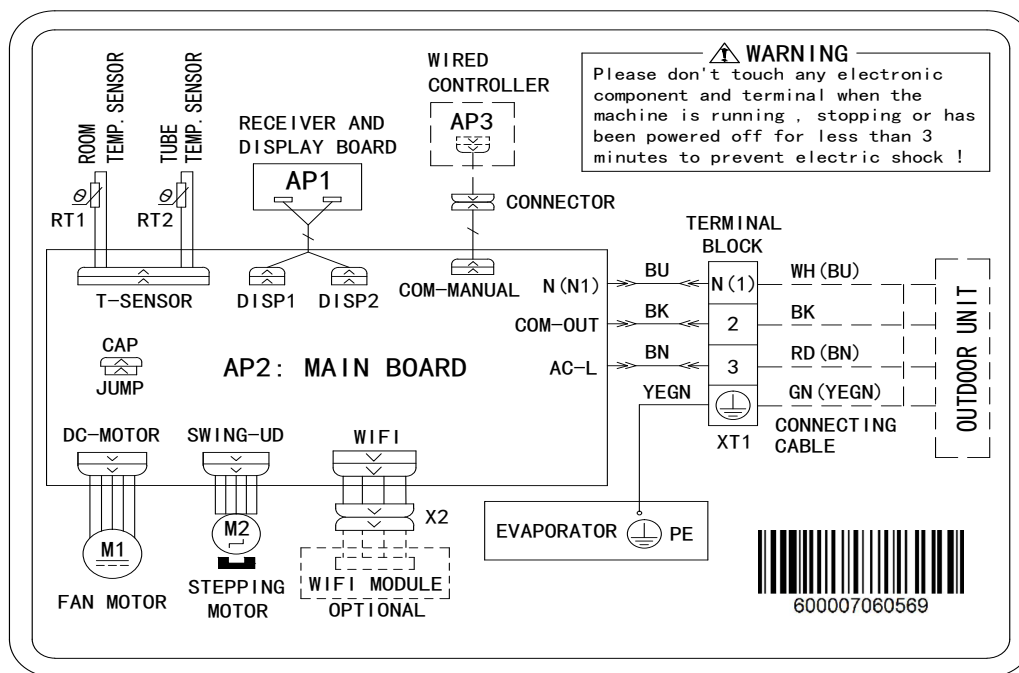

NOTE:Wiring diagrams in this catalogue are included only as reference. The manufacturer follows a continuous policy of product and data improvement and reserves the right to change designs and specifications without prior notice. Always consult unit's identification nameplate to verify actual requirements of the unit.

Wall Unit

Indoor unit - Cooling only - 4MYW2318A1 - 4MYW2324A1

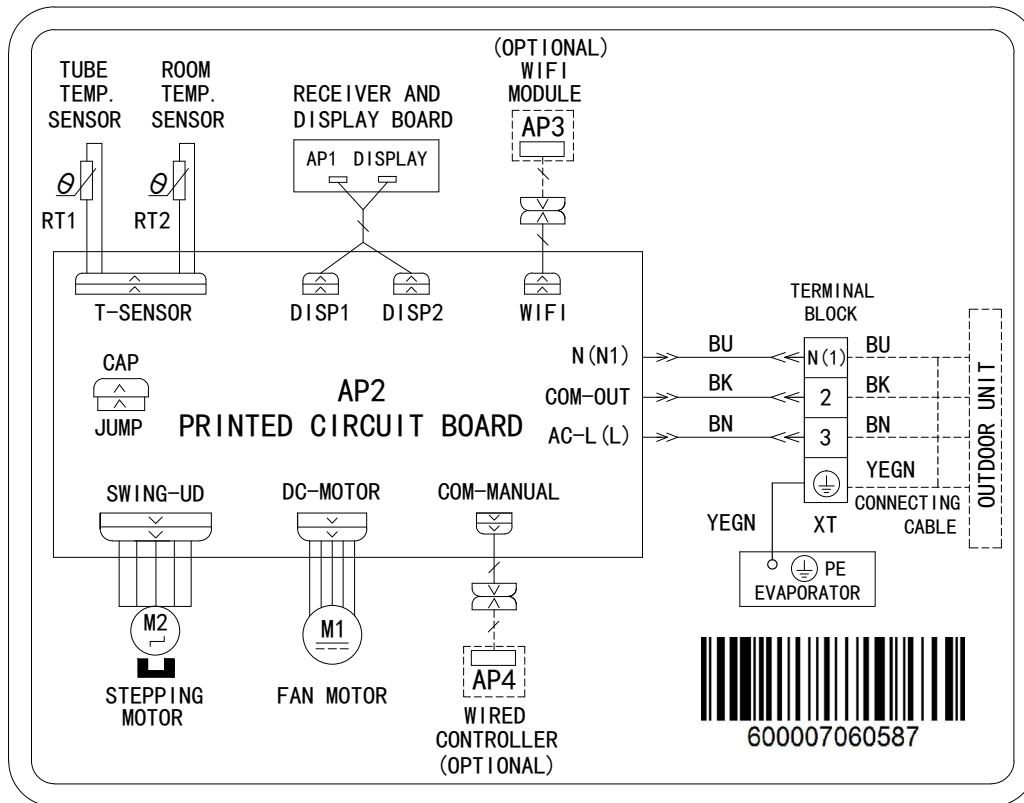

Indoor unit - Heat pump - 4MXW2318A1 - 4MXW2324A1

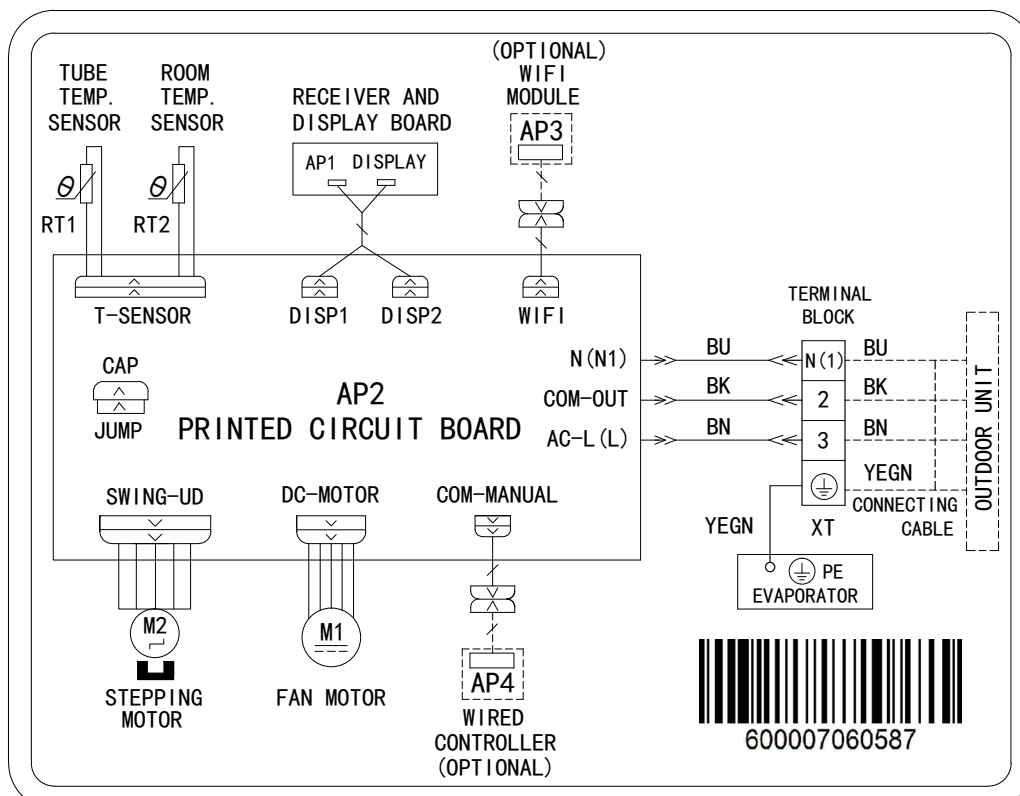

NOTE:Wiring diagrams in this catalogue are included only as reference. The manufacturer follows a continuous policy of product and data improvement and reserves the right to change designs and specifications without prior notice. Always consult unit's identification nameplate to verify actual requirements of the unit.

Indoor unit - Cooling only - 4MYW2330A1 - 4MYW2336A1

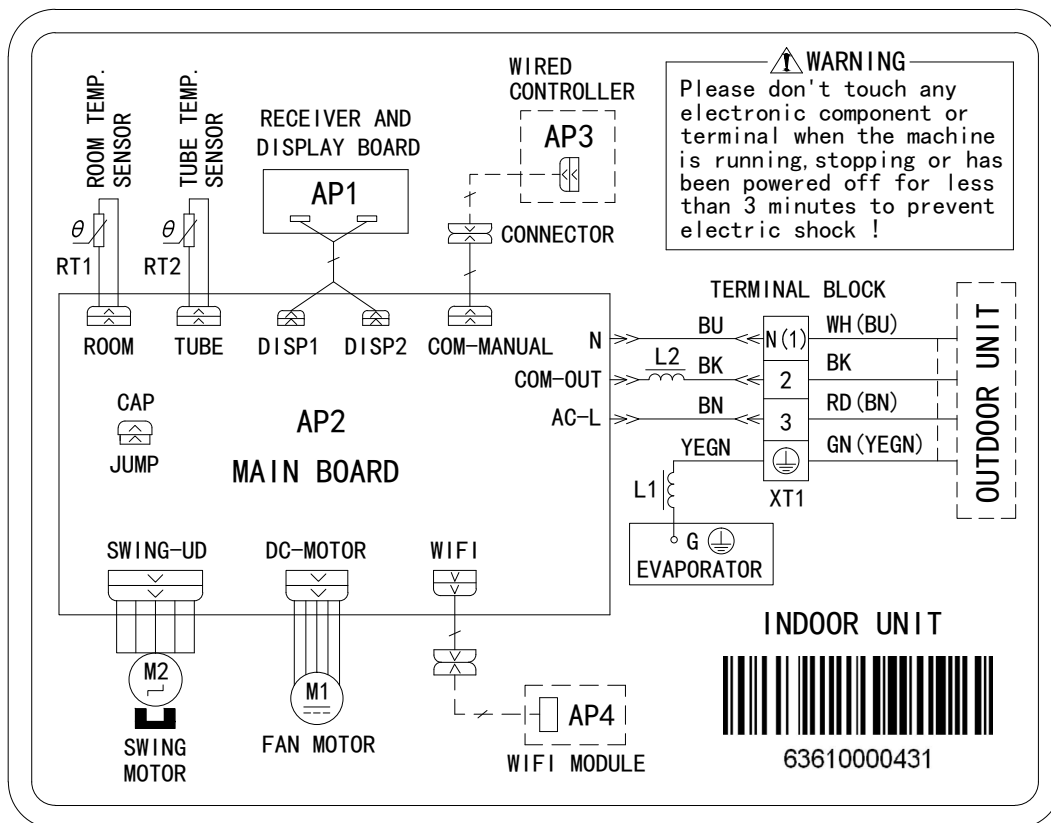

Indoor unit - Heat pump - 4MXW2330A1 - 4MXW2336A1

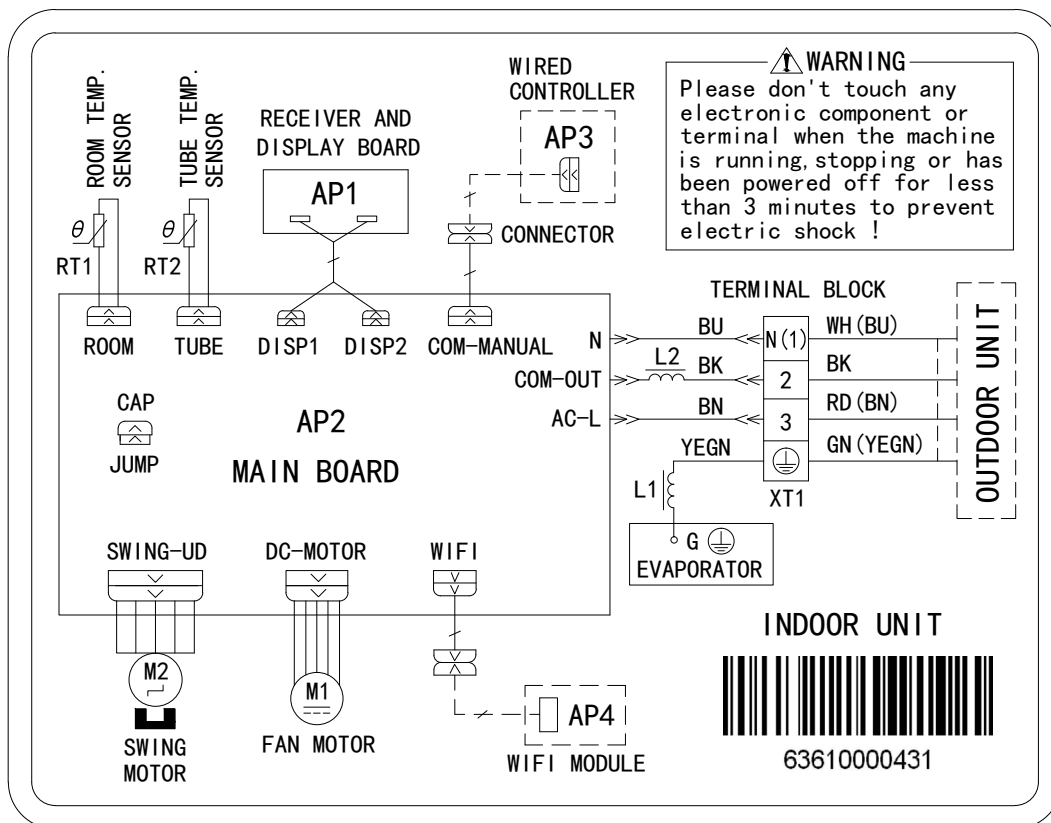

Wall Unit

Outdoor unit - Cooling only - 4TYK2309A9

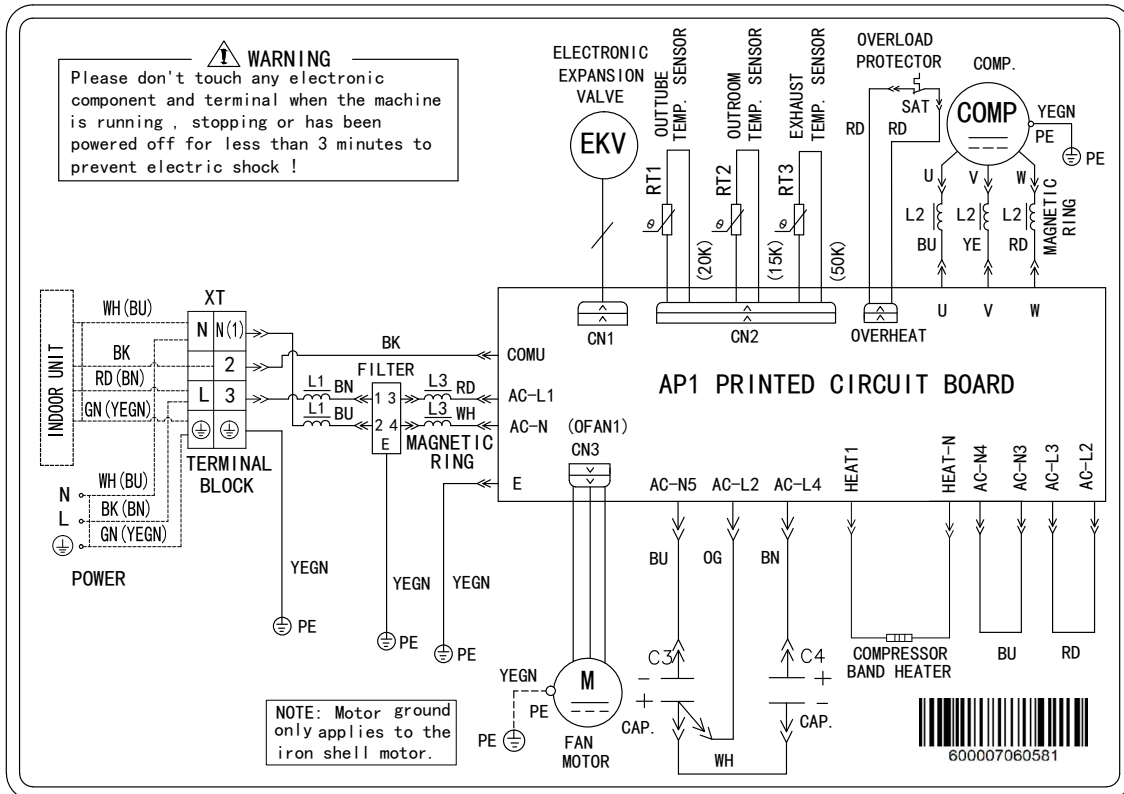

Outdoor unit - Cooling only - 4TYK2312A9

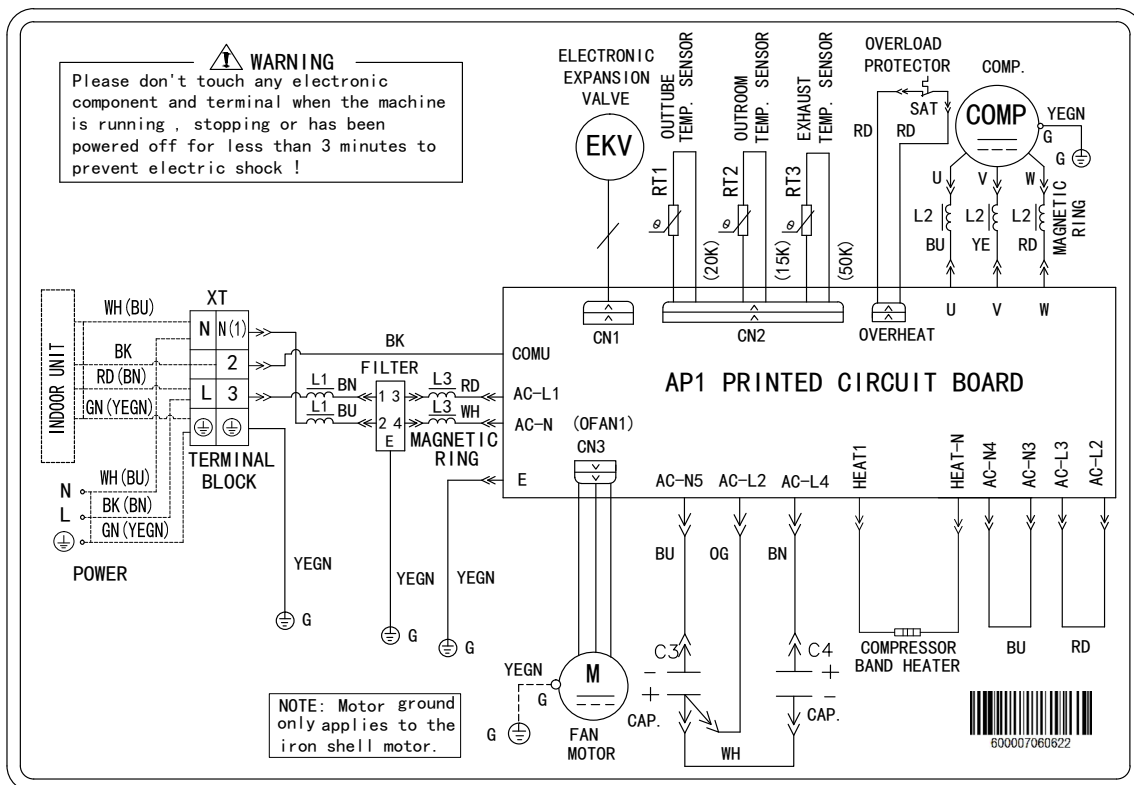

NOTE:Wiring diagrams in this catalogue are included only as reference. The manufacturer follows a continuous policy of product and data improvement and reserves the right to change designs and specifications without prior notice. Always consult unit's identification nameplate to verify actual requirements of the unit.

Outdoor unit - Cooling only - 4TYK2309A1- 4TYK2312A1

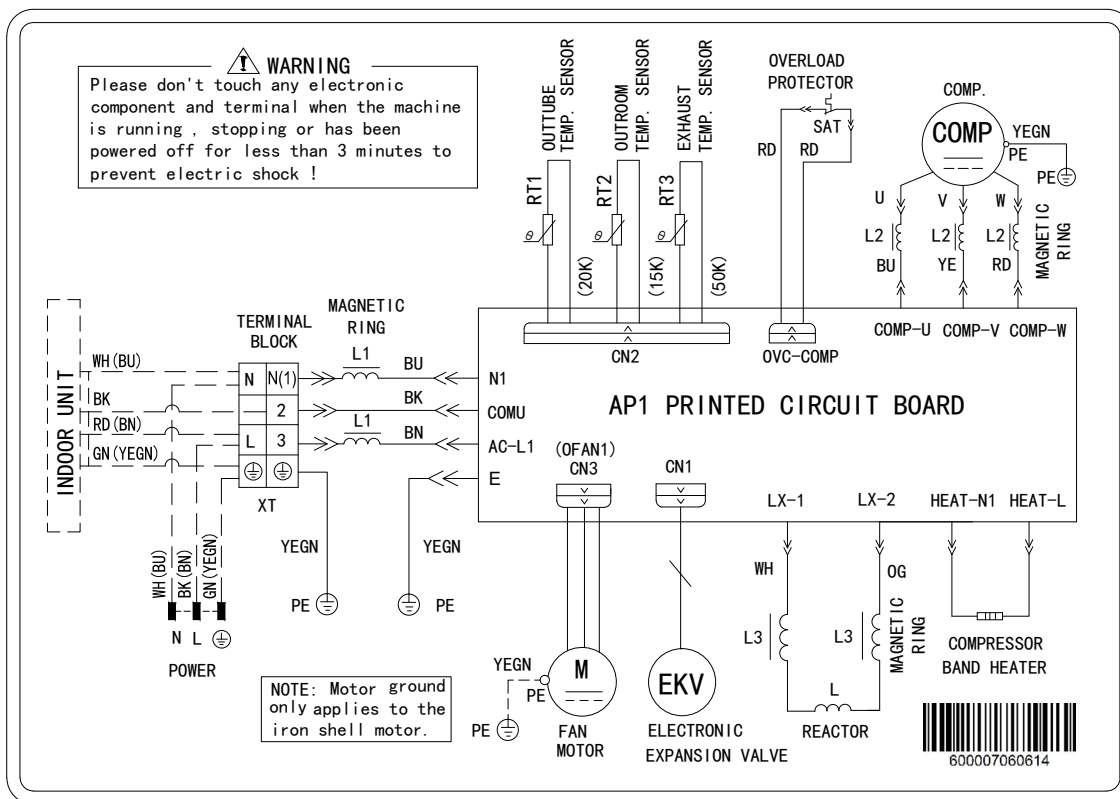

Outdoor unit - Heat pump - 4TXK2309A1- 4TXK2312A1

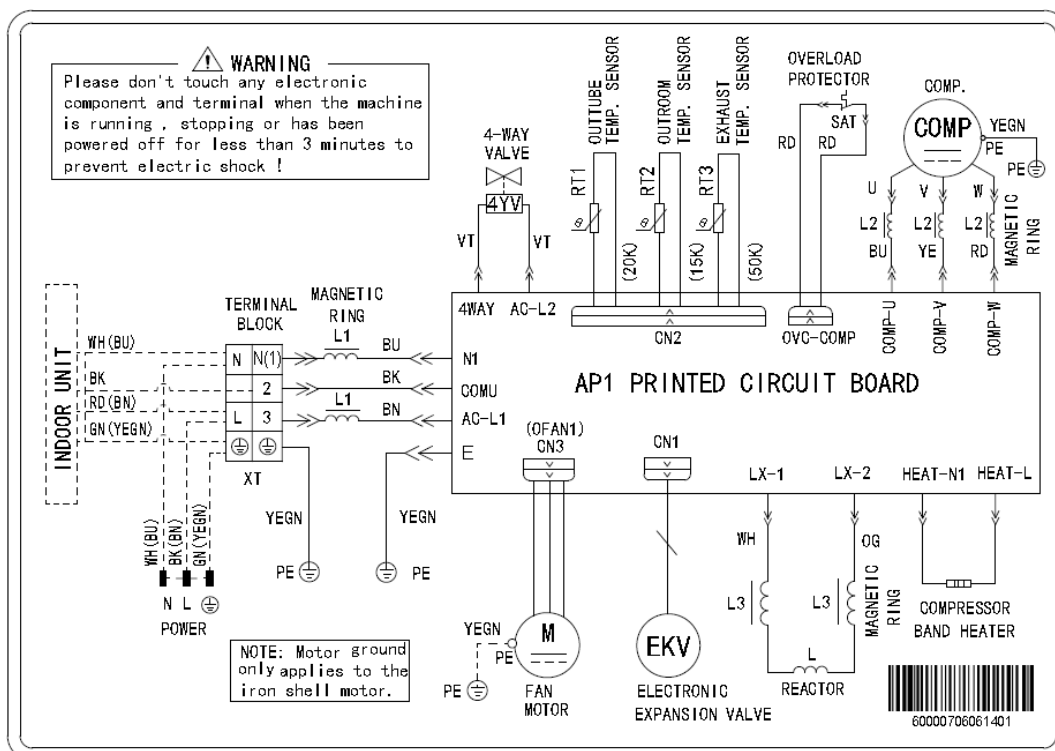

NOTE: Wiring diagrams in this catalogue are included only as reference. The manufacturer follows a continuous policy of product and data improvement and reserves the right to change designs and specifications without prior notice. Always consult unit's identification nameplate to verify actual requirements of the unit.

Wall Unit

Outdoor unit - Cooling only - 4TYK2318A1

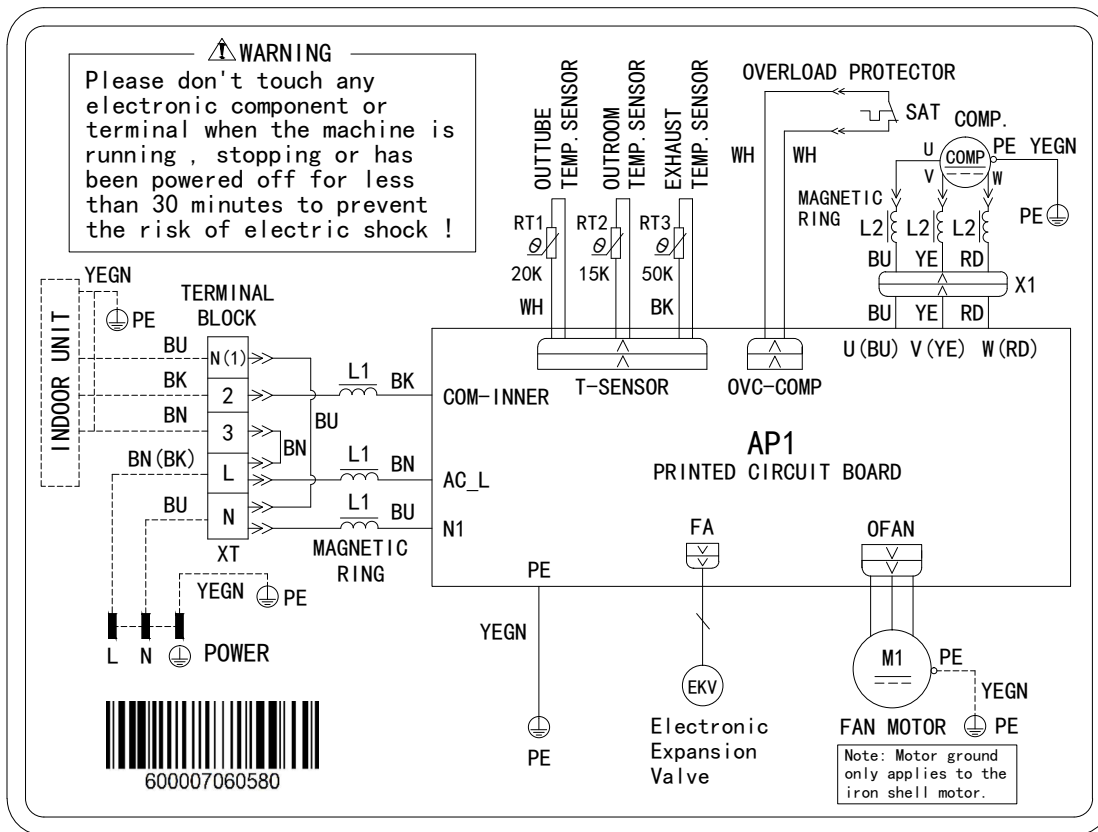

Outdoor unit - Heat pump - 4TXK2318A1

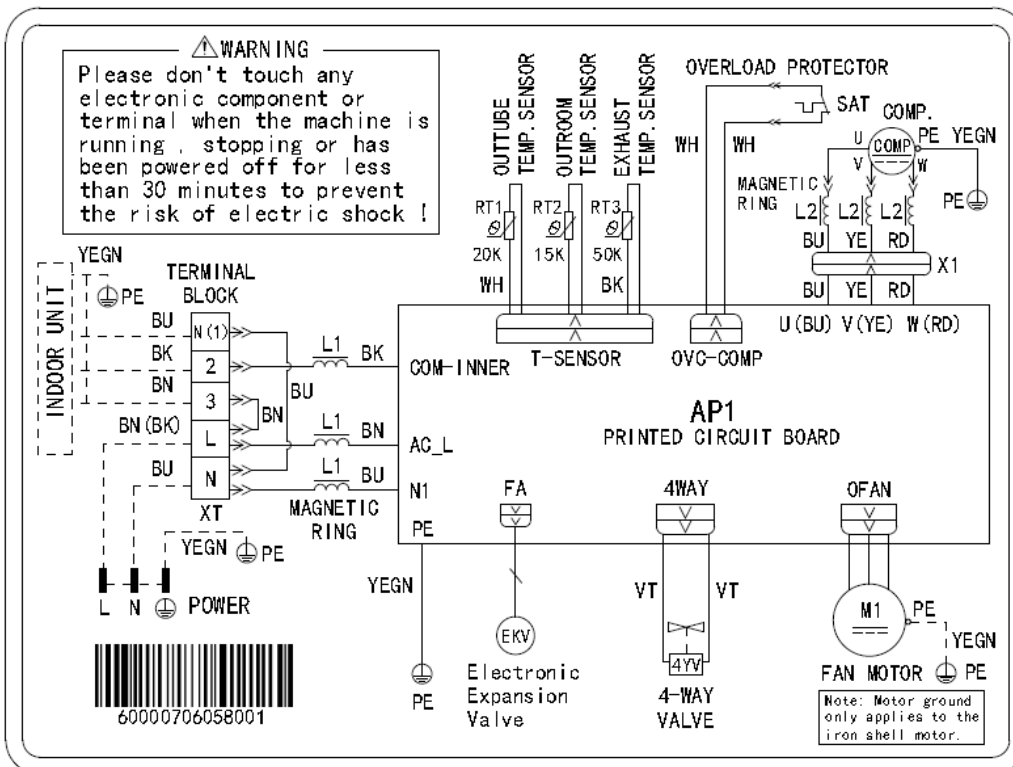

NOTE:Wiring diagrams in this catalogue are included only as reference. The manufacturer follows a continuous policy of product and data improvement and reserves the right to change designs and specifications without prior notice. Always consult unit's identification nameplate to verify actual requirements of the unit.

Outdoor unit - Cooling only - 4TYK2324A1

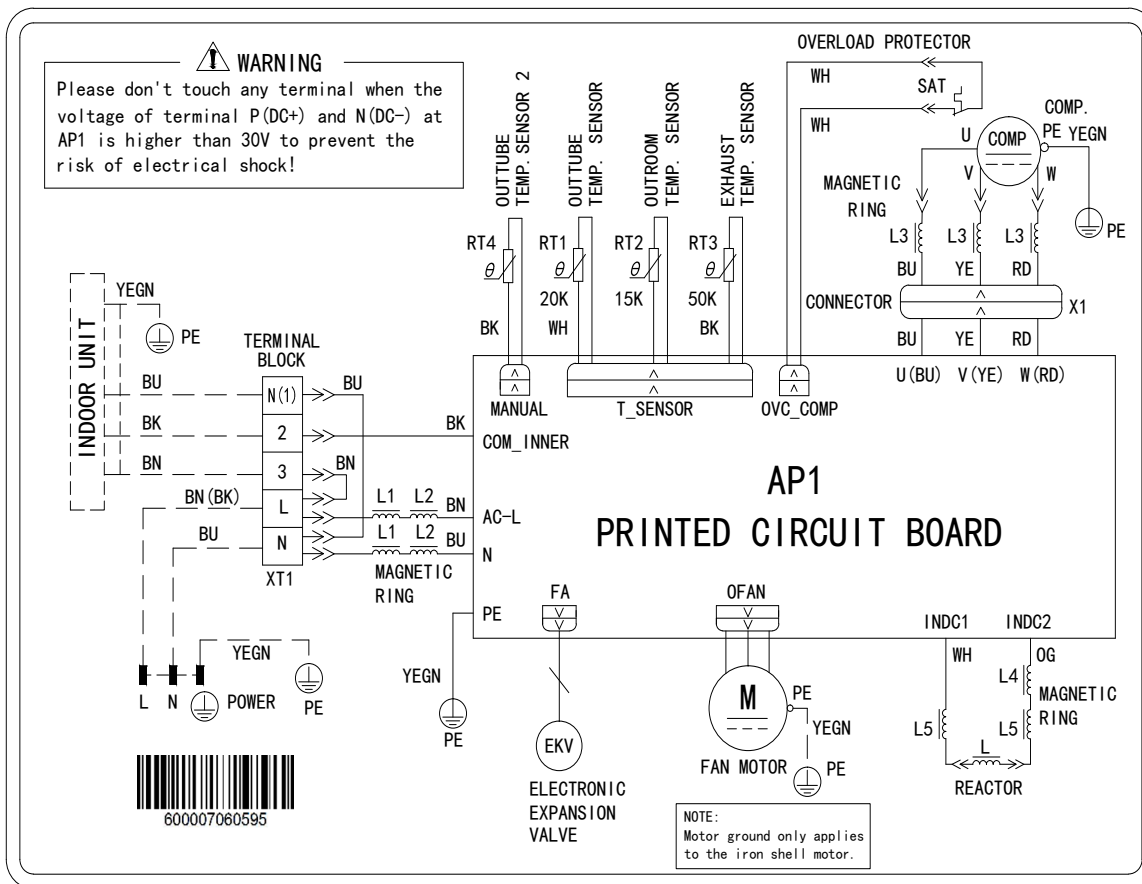

Outdoor unit - Heat pump - 4TXK2324A1

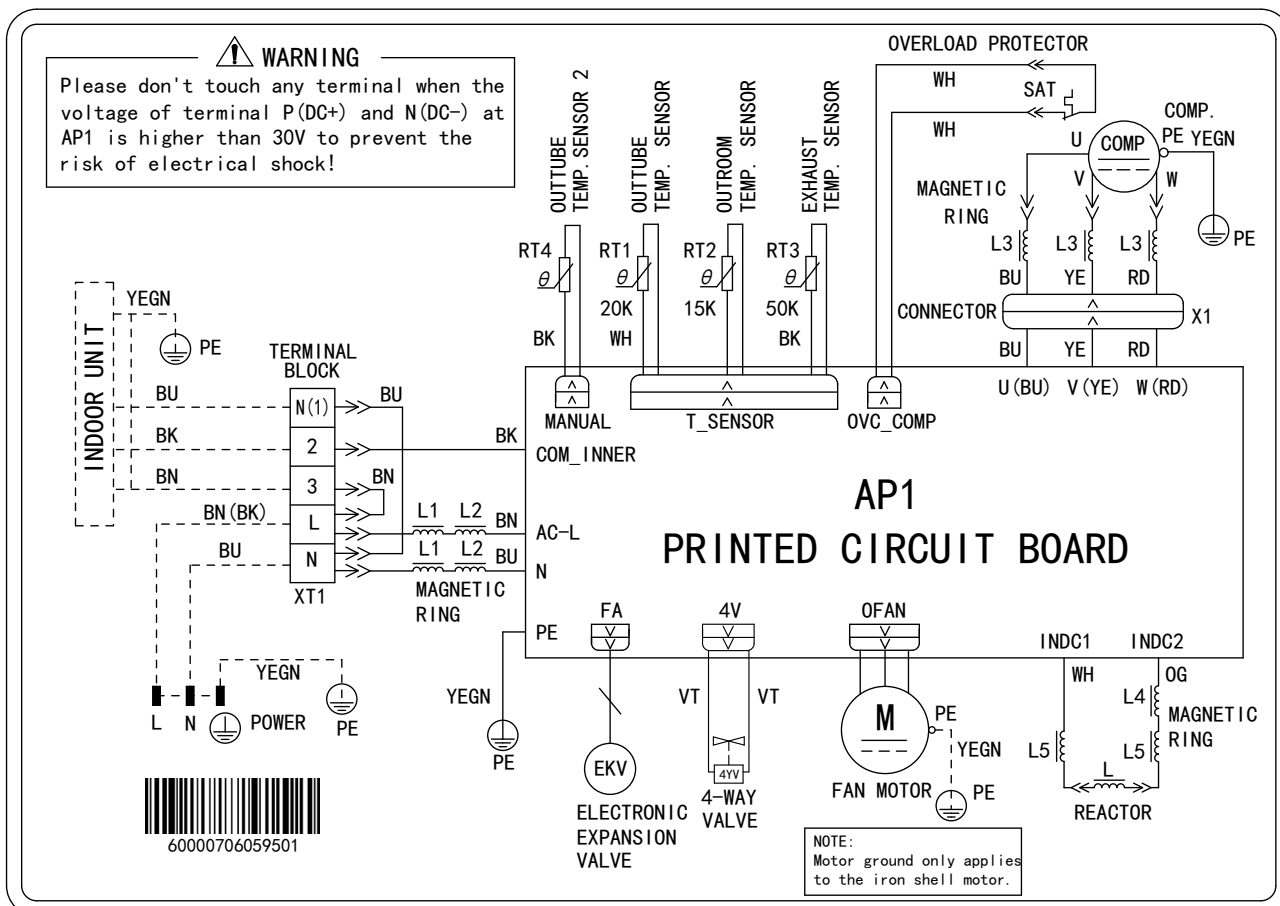

Outdoor unit - Cooling only - 4TYK2330A1- 4TYK2336A1

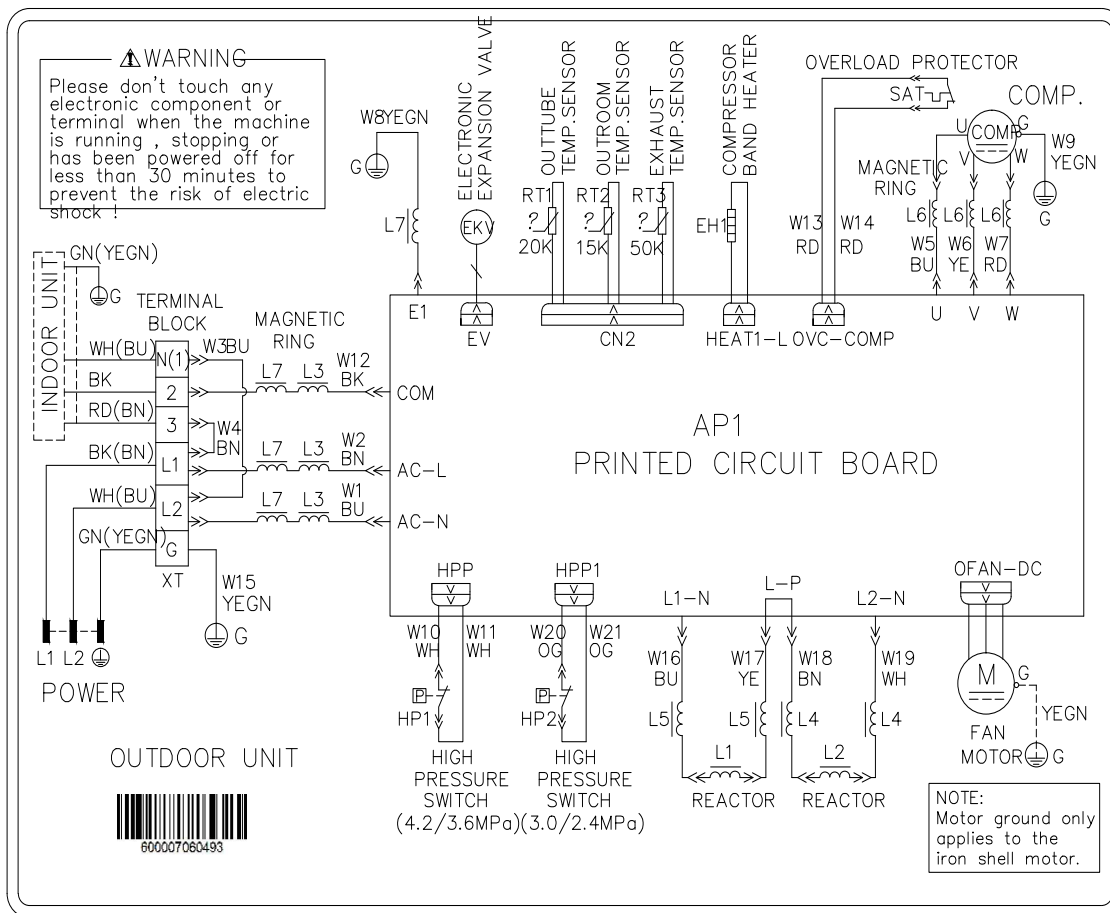

Outdoor unit - Heat pump - 4TXK2330A1 - 4TXK2336A1

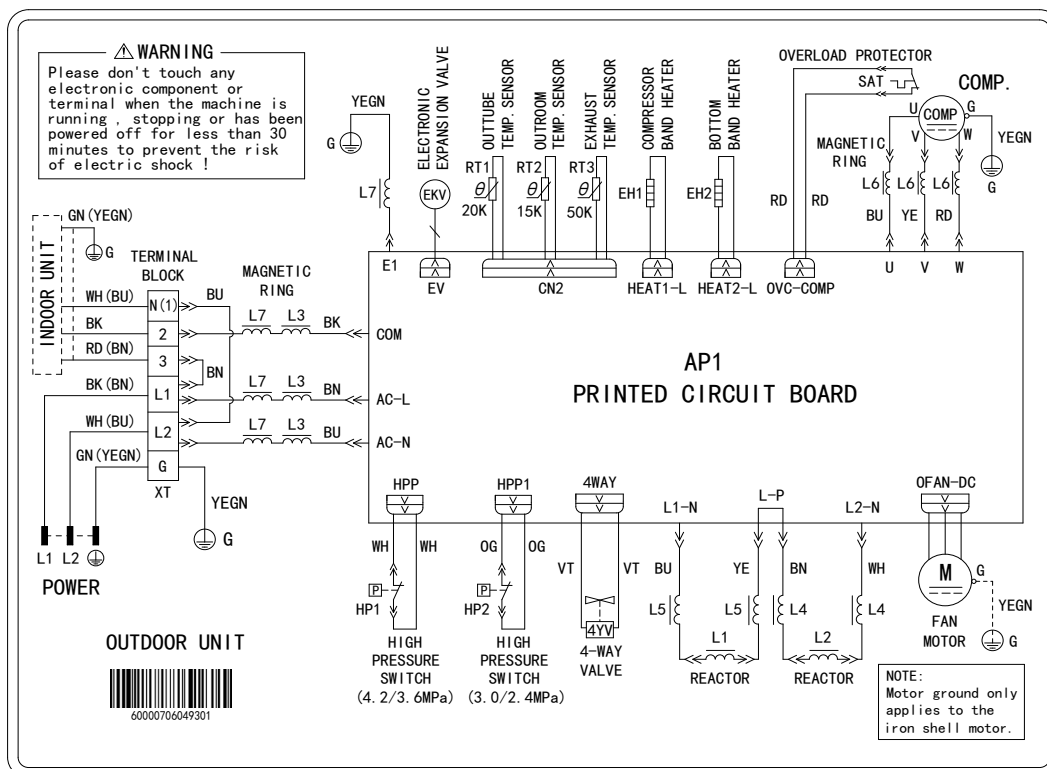

Wall Unit

Indoor unit dimensions

9K-12K Indoor units

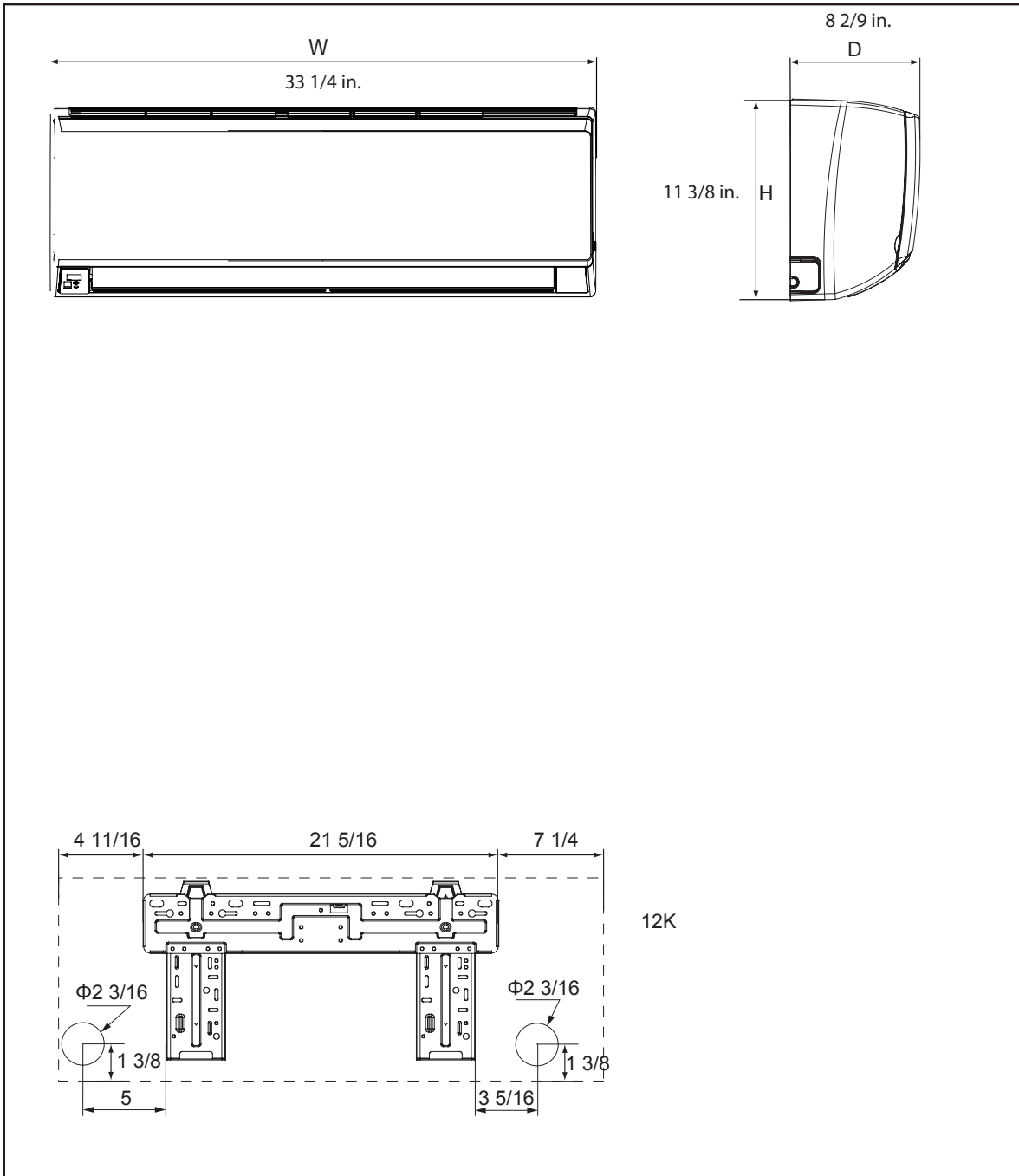

Indoor unit dimensions (cont.)

18K-24K Indoor units

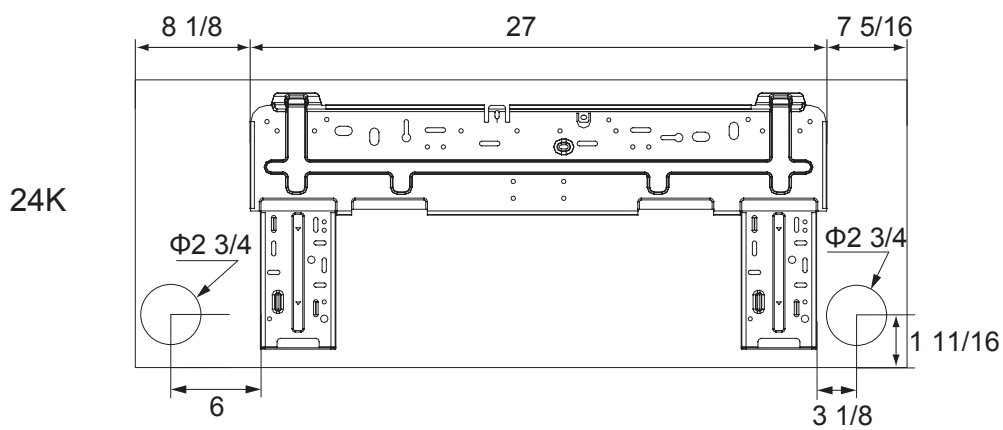
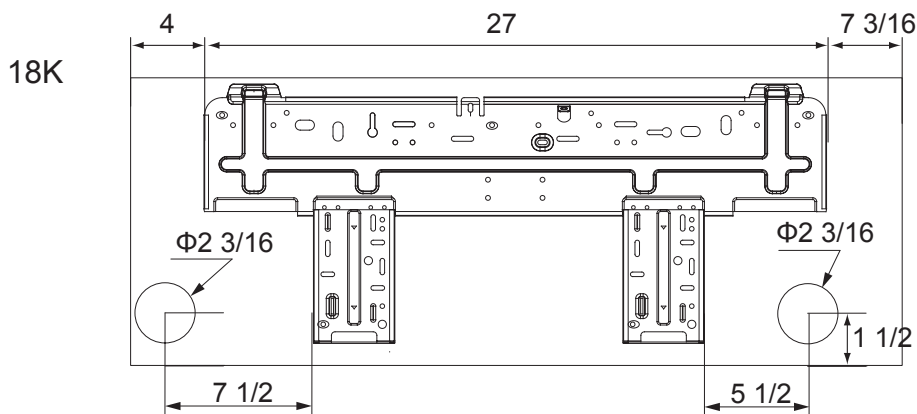
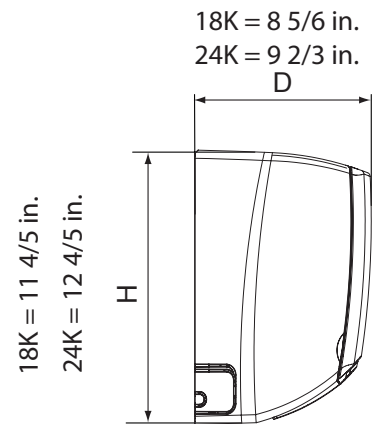
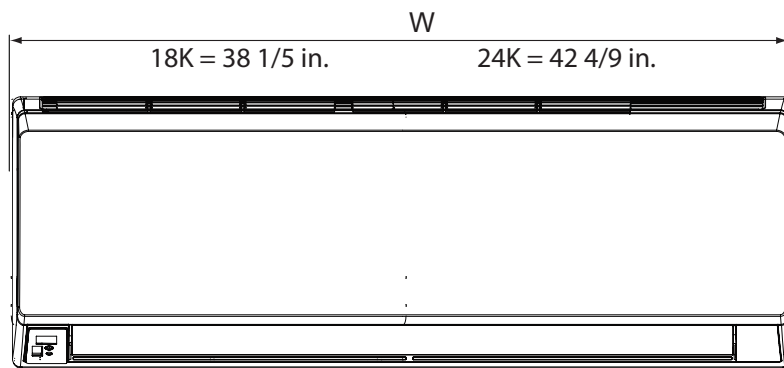

Wall Unit

Indoor unit dimensions

9K-12K Outdoor units

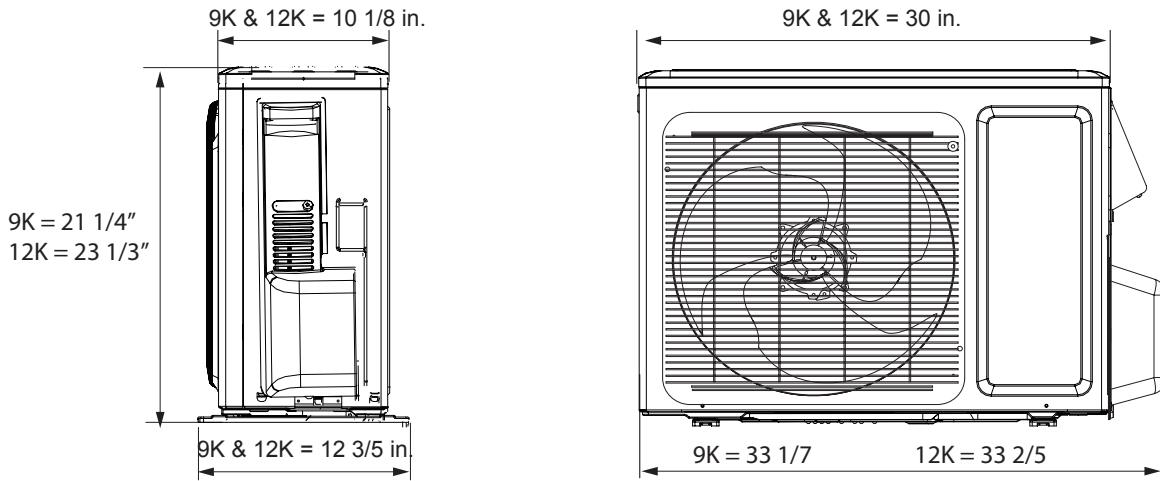

18K-24K Outdoor units

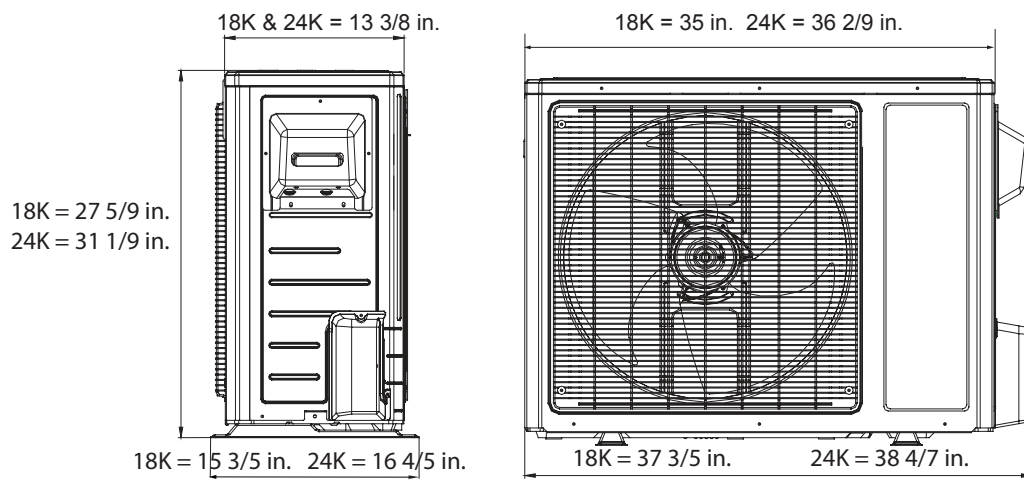

Indoor/outdoor unit dimensions

30K-36K Indoor units

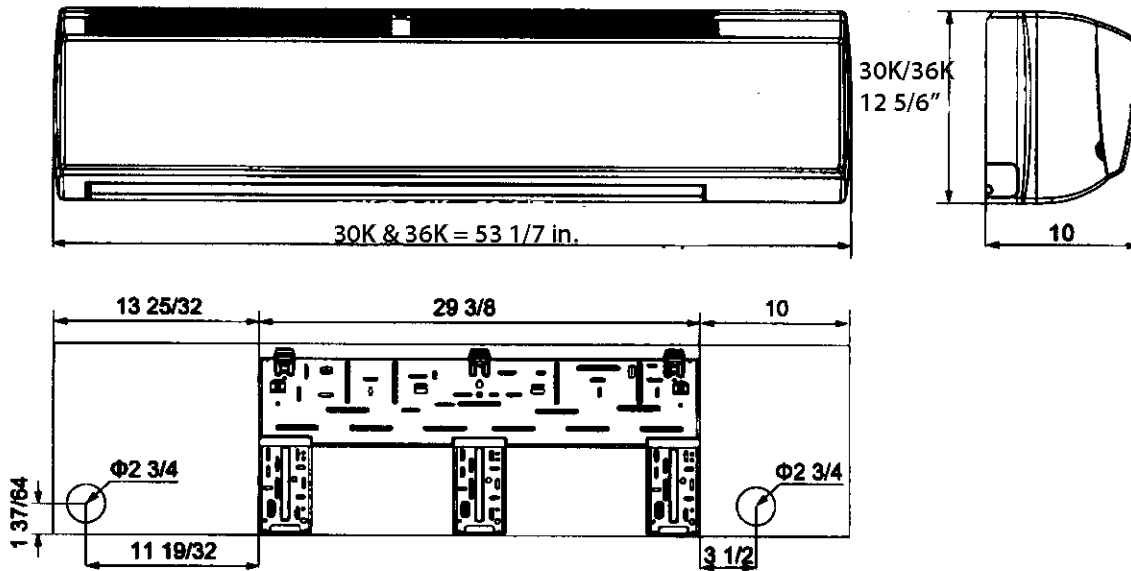

30K-36K Outdoor units

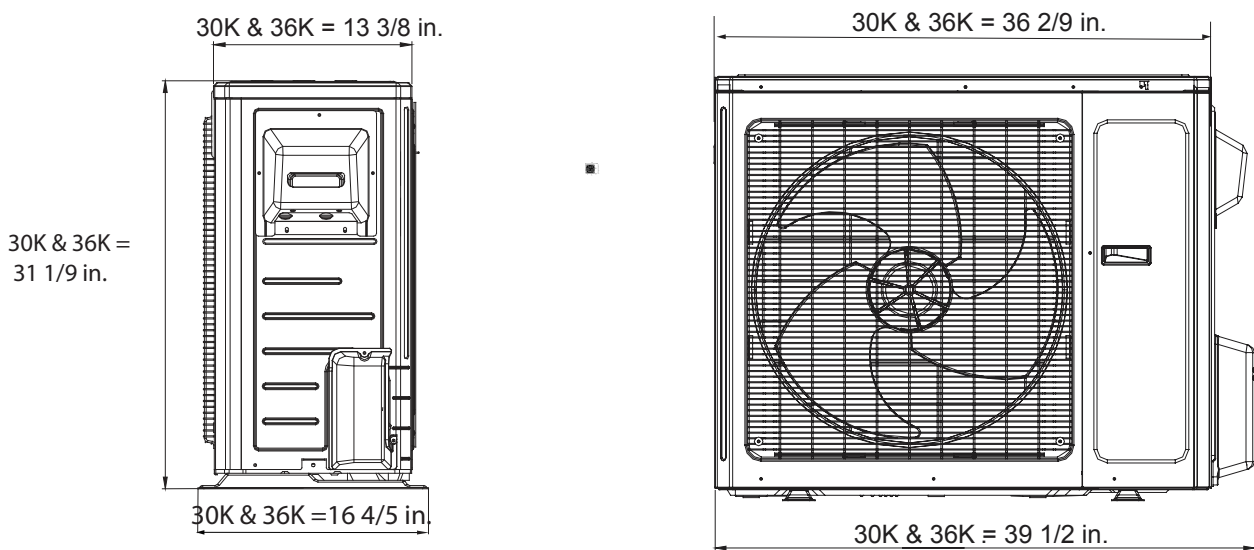

Wall Unit

Common error codes

Error code	Type of malfunction	Recommendation
E5	Overcurrent protection AC	Restart the unit motor. If error persists, contact your local distributor
E8 / H4	High temperature protection	
H6	Indoor fan motor error	
C5	Bridge cap malfunction protection	Contact your local distributor
F1	Indoor ambient sensor open or short circuit	
F2	Indoor pipe sensor open or short circuit	

In case of additional error codes, contact your local distributor for service.

If any of the following should occur, shut the unit off and contact your local distributor for service:

- Power cable overheats or is damaged
- There is a smell of something that has burnt
- The unit trips the breaker panel or it shuts off frequently without reaching the temperature setpoint
- During operation abnormal noise is detected
- Water leak is detected

Emergency operation

If the remote control is damaged or is lost, use the auxiliary button to turn on or turn off the air conditioner. Open the front panel and press the auxiliary button to on or off. When the unit is being operated through the auxiliary button, the unit will work only in automatic mode.

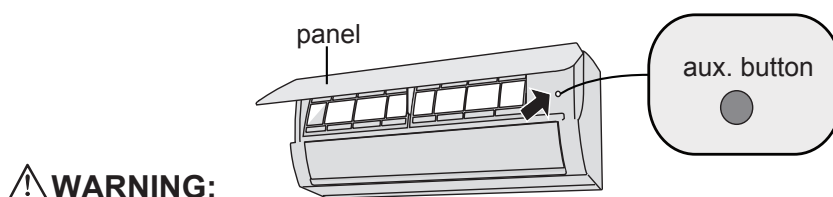

⚠ WARNING:

Use an insulated object such as an electrician's screwdriver to press the aux. button.

Error detection



CAUTION

Inappropriate operation can lead to personal injury or unit malfunction.

- If a malfunction is detected, shut off the main power supply switch. Contact your distributor or service agent. If the unit continues to operate under the malfunction condition, the unit could suffer damages or cause fire or electric shock.
- Do not try to move the units. Contact your service agent or installer for needed repairs or to relocate the units.
- Verify the following points before calling your distributor.

Condition		Possible cause
The unit does not work	When activating the unit	The overload protector delays the unit startup during three minutes
	When applying power	The keeps on standby during one minute
Mist is observed coming from the unit	When starting the cooling cycle	High indoor humidity cools rapidly
Noise coming from the unit	Cracking noise at unit startup	This sound occurs during the activation of the electronic expansion valve
	Noise during cooling	Sound of refrigerant gas flowing through the unit
	Noise at unit startup and and also when stopping	This sound occurs when refrigerant gas starts flowing or stops flowing.
	Slight noise during unit operation of after ending operation	Sound of the drain system during unit operation
Cracking sound during operation and after operation	Cracking sound during operation and after operation	This sound occurs when the unit panels expand or contract due to change in temperature
Unit expels dust	When the unit has been inactive during a long period	Dust is expelled from the indoor unit
Unit expels an odor	When the unit is in operation	The room odor absorbed by the unit is expelled once again
Unit continues to run after it has been shut off	After the idoor unit receives the "stop" sign, the fan continues to run	The indoor fan motor will continue to run during 20-70 seconds to employ excess cooling or heating and to prepare for the following operation
Mode conflict	COOL or HEAT mode cannot be operated	When switching cooling and heating modes, the outdoor unit will take a few minutes to change the direction of refrigerant flow and to pre-heat the coil in heating mode. COOL mode will not conflict with DRY mode nor with FAN mode
Error code	E7 appears on one or more indoor units	E7 indicates that this indoor unit is soliciting a mode that conflicts with the outdoor unit mode. E7 will disappear a few seconds later once the unit mode changes to engage the outdoor unit mode. The outdoor unit mode will change only when all indoor units have changed to the new mode

NOTE: If problem persists after attending and adopting the appropriate measures for the above indications, shut the unit off immediately and contact your local service agency. Diagnostics and repairs must be performed by authorized service technicians.

Wall Unit

Indoor unit maintenance

1. Clean the outdoor surface of the unit using a dry or humid cloth.
2. If the unit contains debris, it must be cleaned with a mild detergent. Do not use chemical solutions or flammable liquids for this purpose. Dry the surface using a dry and soft cloth.
3. Clean the filter at least every three months. Clean it more often if the area is very dusty or smoky.
4. Open the front panel of the indoor unit.
5. Remove the filter holding it from the edges and pulling downward.
6. Clean the filter with a vacuum cleaner or rinse it with clean and cold water.
7. If the filter is very dirty, use warm water (below 115°F/ 45°C). A soft detergent may be used only if debris cannot be removed with the warm water. Rinse the filter completely before leaving it to air dry. If the filter cannot be cleaned appropriately, contact your distributor to order a filter replacement.
8. Leave the filter to air dry to avoid deformity. Do not dry the filter under direct sun rays.
9. Reinstall the filter on its hooks and close the panel.

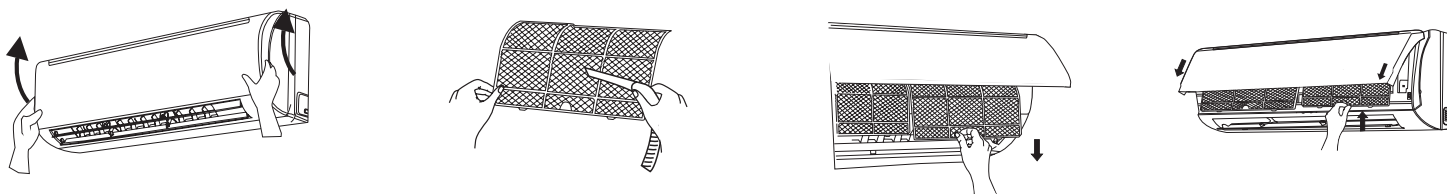

WARNING

1. After removing the filter and in order to prevent injuries, do not touch evaporator fins.
2. To dry the filter and avoid fire or deformity of same, do not use flame, hair drier or any other source of heat.

Maintenance

To prolong the life of the unit, it is recommendable to program regular maintenance for the equipment to be performed by knowledgeable and trained personnel.

Outdoor heat exchanger

Outdoor heat exchanger must be checked and cleaned once every two months. Use a vacuum cleaner with nylon brush to remove dust and debris from its surface. Expel dust through compressed air if available. Never use water to clean the heat exchanger.

Drain piping

On a regular basis, check the condition of all drain piping to verify it is free of obstructions and that it does not show any signs of possible condensate leaking that could cause damages by water.

Checking of the unit before the start of the season to confirm:

1. If the the entry/outlet of the indoor/outdoor unit is capped or obstructed
2. If the grounding cable is secured in place
3. If batteries of the wireless remote control unit have been replaced
4. If the filter mesh has been cleaned and placed once again in its position
5. After long periods of shutdown due to cold temperatures, open the main power breaker during 8 hours before operating the unit in order to reheat the compressor crankcase heater
6. If the indoor unit is securely installed
7. If something looks abnormal, contact your equipment installer

Maintenance at the end of the season:

1. Cut all power supply to the unit
2. Clean the filter mesh as well as both indoor and outdoor units
3. Remove dust and debris from both indoor and outdoor units
4. If oxidation is observed, use anti-oxidant paint to stop oxide propagation

Parts replacement

Acquire parts from your local Distributor Service Center.

NOTE: During leak tests, never mix oxygen, ethylene (acetylene) and other dangerous gases inside the refrigerant circuit. Nitrogen must be used for leak testing.

Aftermarket service

If problems arise with the unit or if maintenance is required, contact your local service center or distributor.