



Installation Guide

Agility™ Water-cooled Chillers

With Symbio™ Controls

Disassembly and Reassembly



Model: HDWA PC 747

X39641413002

⚠ SAFETY WARNING

Only qualified personnel should install and service the equipment. The installation, starting up, and servicing of heating, ventilating, and air-conditioning equipment can be hazardous and requires specific knowledge and training. Improperly installed, adjusted or altered equipment by an unqualified person could result in death or serious injury. When working on the equipment, observe all precautions in the literature and on the tags, stickers, and labels that are attached to the equipment.

November 2022

HDWA-SVN003B-EN

TRANE
TECHNOLOGIES



Introduction

Read this manual thoroughly before operating or servicing this unit.

Warnings, Cautions, and Notices

Safety advisories appear throughout this manual as required. Your personal safety and the proper operation of this machine depend upon the strict observance of these precautions.

The three types of advisories are defined as follows:



Indicates a potentially hazardous situation which, if not avoided, could result in death or serious injury.



Indicates a potentially hazardous situation which, if not avoided, could result in minor or moderate injury. It could also be used to alert against unsafe practices.



Indicates a situation that could result in equipment or property-damage only accidents.

Important Environmental Concerns

Scientific research has shown that certain man-made chemicals can affect the earth's naturally occurring stratospheric ozone layer when released to the atmosphere. In particular, several of the identified chemicals that may affect the ozone layer are refrigerants that contain Chlorine, Fluorine and Carbon (CFCs) and those containing Hydrogen, Chlorine, Fluorine and Carbon (HCFCs). Not all refrigerants containing these compounds have the same potential impact to the environment. Trane advocates the responsible handling of all refrigerants-including industry replacements for CFCs and HCFCs such as saturated or unsaturated HFCs and HCFCs.

Important Responsible Refrigerant Practices

Trane believes that responsible refrigerant practices are important to the environment, our customers, and the air conditioning industry. All technicians who handle refrigerants must be certified according to local rules. For the USA, the Federal Clean Air Act (Section 608) sets forth the requirements for handling, reclaiming, recovering and recycling of certain refrigerants and the equipment that is used in these service procedures. In addition, some states or municipalities may have additional requirements that must also be adhered to for responsible management of refrigerants. Know the applicable laws and follow them.

⚠ WARNING

Proper Field Wiring and Grounding Required!

Failure to follow code could result in death or serious injury.

All field wiring **MUST** be performed by qualified personnel. Improperly installed and grounded field wiring poses **FIRE** and **ELECTROCUTION** hazards. To avoid these hazards, you **MUST** follow requirements for field wiring installation and grounding as described in **NEC** and your local/state/national electrical codes.

⚠ WARNING

Personal Protective Equipment (PPE) Required!

Failure to wear proper PPE for the job being undertaken could result in death or serious injury.

Technicians, in order to protect themselves from potential electrical, mechanical, and chemical hazards, **MUST** follow precautions in this manual and on the tags, stickers, and labels, as well as the instructions below:

- **Before installing/servicing this unit, technicians MUST put on all PPE required for the work being undertaken (Examples; cut resistant gloves/sleeves, butyl gloves, safety glasses, hard hat/bump cap, fall protection, electrical PPE and arc flash clothing). ALWAYS refer to appropriate Safety Data Sheets (SDS) and OSHA guidelines for proper PPE.**
- **When working with or around hazardous chemicals, ALWAYS refer to the appropriate SDS and OSHA/GHS (Global Harmonized System of Classification and Labelling of Chemicals) guidelines for information on allowable personal exposure levels, proper respiratory protection and handling instructions.**
- **If there is a risk of energized electrical contact, arc, or flash, technicians MUST put on all PPE in accordance with OSHA, NFPA 70E, or other country-specific requirements for arc flash protection, PRIOR to servicing the unit. NEVER PERFORM ANY SWITCHING, DISCONNECTING, OR VOLTAGE TESTING WITHOUT PROPER ELECTRICAL PPE AND ARC FLASH CLOTHING. ENSURE ELECTRICAL METERS AND EQUIPMENT ARE PROPERLY RATED FOR INTENDED VOLTAGE.**

⚠ WARNING**Follow EHS Policies!**

Failure to follow instructions below could result in death or serious injury.

- All Trane personnel must follow the company's Environmental, Health and Safety (EHS) policies when performing work such as hot work, electrical, fall protection, lockout/tagout, refrigerant handling, etc. Where local regulations are more stringent than these policies, those regulations supersede these policies.
- Non-Trane personnel should always follow local regulations.

Copyright

This document and the information in it are the property of Trane, and may not be used or reproduced in whole or in

part without written permission. Trane reserves the right to revise this publication at any time, and to make changes to its content without obligation to notify any person of such revision or change.

Trademarks

All trademarks referenced in this document are the trademarks of their respective owners.

Revision History

- Updated drive cooling fluid table information.
- Updated instructions for removing motor terminal box to clarify instructions for units not equipped with an output inductor, and added supporting figure.
- Updated SRRL information in Control and Options panel tables in Appendix A.



Table of Contents

Preparing, De-energizing, Locking out, and Securing from Tipping	5	Removing the Condenser Liquid Line	22
Draining the Drive Cooling System	8	Removing the Condenser Discharge Pipe	22
Removing the Upper and Lower Cross-Ties	9	Removing the Motor Terminal Box	23
Removing the Motor Terminal Box and Disconnecting the Motor Terminals	10	Removing the Evaporator Main EXV Line	24
Removing the Check Valve	11	Removing the Economizer to Compressor Line	25
Disconnecting the Global Connectors	12	Removing the Compressor Interstage Line	25
Disconnecting the Condenser Drain Line	13	Removing the Condenser Liquid Level Sensor	26
Moving the Lifting Brackets to the Common Shell (both ends)	14	Removing the Options Panel (if present)	27
Disconnecting the Conduit Connections at the Back of the Electrical Panel	16	Removing the Drive Panel	29
Disconnecting and Plugging the Drive Cooling Lines from the Braze Plate Heat Exchanger (BPHE)	17	Removing the Compressor	31
Separating the Primary Subassemblies	18	Removing the Economizer	35
Transferring One Half to the New Location and Securing	20	Reassembly Instructions for HDWA	38
Additional Disassembly	21	Installation Instructions for Non-Marine Waterbox Hinge Assembly	38
Removing the Cross-tie Brackets	21	Installation Instructions for Marine Waterbox Hinge Assembly	40
		Disassembly Instructions Marine and Non-Marine Waterboxes	41
		Appendix A : Tools, Weights, Lubrication, Torques	42



Preparing, De-energizing, Locking out, and Securing from Tipping

⚠ WARNING

Heavy Object!

Failure to follow instructions below could result in unit dropping which could result in death or serious injury, and equipment or property-only damage.

Ensure that all the lifting equipment used is properly rated for the weight of the unit being lifted. Each of the cables (chains or slings), hooks, and shackles used to lift the unit must be capable of supporting the entire weight of the unit. Lifting cables (chains or slings) may not be of the same length. Adjust as necessary for even unit lift.

⚠ WARNING

Hazardous Voltage w/Capacitors!

Failure to disconnect power and discharge capacitors before servicing could result in death or serious injury.

Disconnect all electric power, including remote disconnects and discharge all motor start/run capacitors before servicing. Follow proper lockout/tagout procedures to ensure the power cannot be inadvertently energized. For variable frequency drives or other energy storing components provided by Trane or others, refer to the appropriate manufacturer's literature for allowable waiting periods for discharge of capacitors. Verify with a CAT III or IV voltmeter rated per NFPA 70E that all capacitors have discharged.

⚠ WARNING

Live Electrical Components!

Failure to follow all electrical safety precautions when exposed to live electrical components could result in death or serious injury.

When it is necessary to work with live electrical components, have a qualified licensed electrician or other individual who has been properly trained in handling live electrical components perform these tasks.

⚠ WARNING

Improper Unit Lift!

Failure to properly lift unit in a LEVEL position could result in unit dropping and possibly crushing operator/ technician which could result in death or serious injury, and equipment or property-only damage.

Test lift unit approximately 24 inches (61 cm) to verify proper center of gravity lift point. To avoid dropping of unit, reposition lifting point if unit is not level.

1. If the unit has been previously installed and connected to a power source, disconnect from the power source prior to disassembly and observe the following electrical requirements:
 - Follow all lockout/tagout procedures prior to performing installation and/or service on the unit.
 - Always wear appropriate personal protective equipment.
 - Wait the required time to allow the capacitor(s) to discharge; this could be up to 30 minutes.
 - Verify that all capacitors are discharged prior to service using a properly rated volt meter.
 - Use appropriate capacitor discharge tool when necessary.
 - Comply with the safety practices recommended in PROD-SVB06*-EN.
 - Remove any wireless device from the top of the AFD panel (if present), and place inside the panel.

Preparing, De-energizing, Locking out, and Securing from Tipping

2. Ensure unit is secure from tipping using one of the following (or similar) methods:
 - Secure to dunnage
 - Secure to building.
 - Add 2-inch schedule 40 pipes as shown in [Figure 1, p. 6](#).

Tools:

- 24 mm wrench or ratchet (ratcheting box end wrenches recommended)
 - Two 2 in. X 72 in. schd 40 steel pipe
 - Four 1 in.–10T rigging shackles
 - Four 16 mm Heavy Duty Swivel Hoist Rings #4000 capacity
 - Four rigging straps
 - Hooks
 - Hoists
3. Reclaim the refrigerant.

Units selected for disassembly will arrive with a 5 PSI nitrogen charge. Units shipped with a refrigerant charge need to have the refrigerant re-claimed before disassembly. Unit valve locations shown in [Figure 3, p. 7](#).

Note: Tools and procedures are as required by the application and facility.

4. If nitrogen holding charge is present, vent the nitrogen to the atmosphere as show in [Figure 2, p. 6](#).

The best practice is to assure ventilation is on. Also residual refrigerant may be in the vessel if it was factory or lab, or special run-tested.

Important: New units that have been factory run–tested contain residual refrigerant; vent discharge outdoors.

Note: Tools and procedures are as required by the application and facility.

Figure 1. Stabilizing pipes

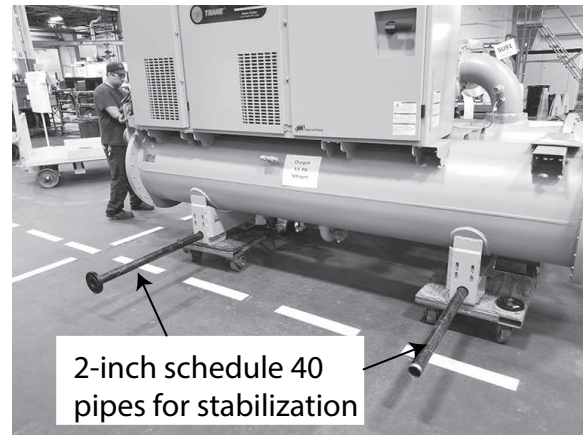

Figure 2. Heat exchanger fill valve



Preparing, De-energizing, Locking out, and Securing from Tipping

The following table shows the callouts for [Figure 3, p. 7](#)

Callout	Description
A	Evaporator fill valve, with gauge port; 3/4 flare fitting
B	Condenser fill valve, with gauge port; 3/4 flare fitting
C	Condenser lower piping drain valve; 5/8 flare fitting
D	Condenser shell drain valve; 5/8 flare fitting
E	Evaporator lower piping drain valve; 5/8 flare fitting

Figure 3. Service valves

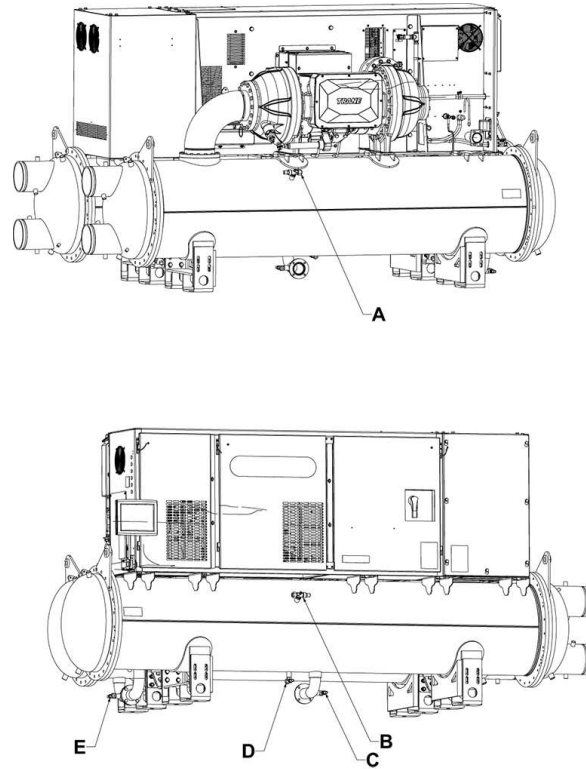

Draining the Drive Cooling System

1. Remove the drain plug as shown in [Figure 4, p. 8](#).

Tools: Clean 5-gallon bucket, 1-1/8 inch wrench, 48-inch hose with 3/4 NPT fitting on the one end.

Figure 4. Cooling system drain plug

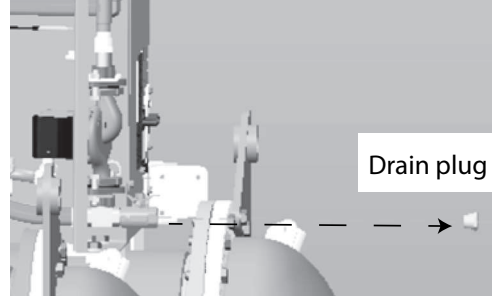

2. Remove the vent plug and reservoir cap to release any vacuum pockets as shown in [Figure 5, p. 8](#).

Tools: 1-1/8 inch wrench

3. Install the hose on the drain valve as shown in [Figure 6, p. 8](#).

4. Place the hose in the bucket.

5. Open the drain valve.

Drive cooling fluid volumes are dependent on VFD frame size (SRRL).

Figure 5. Cooling system vent

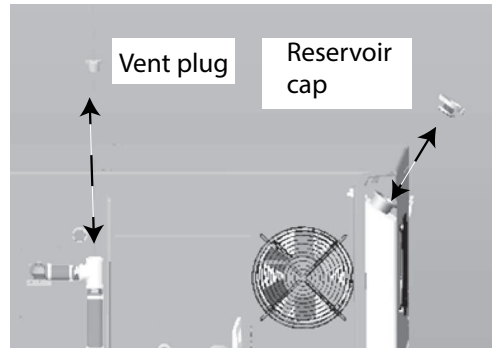

Note: Vent plug is only available on dual drive units.

Table 1. Drive cooling fluid

SRRL	NTON	gal	L
243 to 362	200	1.3	4.9
238 to 532	300/400	1.0	3.8
675	400	1.4	5.3

6. Once drained, re-install the vent and drain plugs, and close the drain valve.

Tools: 1-1/8 inch wrench

Note: Do not disconnect the coolant lines from the BPHE at this time.

Figure 6. Cooling system drain

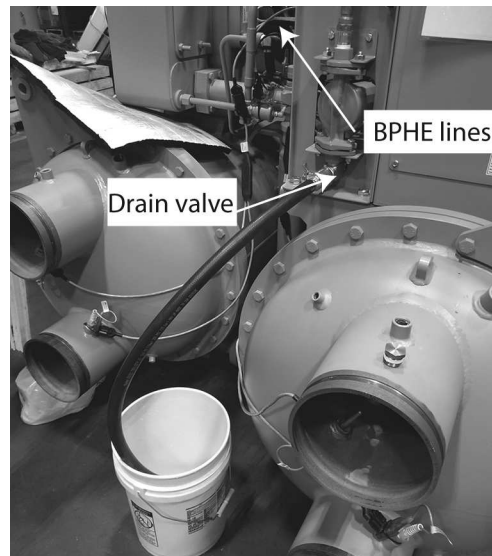

Removing the Upper and Lower Cross-Ties

⚠ WARNING

Heavy Object!

Failure to follow instructions below could result in unit dropping which could result in death or serious injury, and equipment or property-only damage.

Ensure that all the lifting equipment used is properly rated for the weight of the unit being lifted. Each of the cables (chains or slings), hooks, and shackles used to lift the unit must be capable of supporting the entire weight of the unit. Lifting cables (chains or slings) may not be of the same length. Adjust as necessary for even unit lift.

1. Match mark the brackets to the shell joints before removing the brackets.

Tools: marker

Note: Match mark to allow for correct re-assembly. Brackets need to be reinstalled in the same location.

2. Remove a total of sixteen (16) M16 bolts and nuts from one side of the cross brackets (four bolts from one side of all four cross bracket locations).

Tools: 24 mm wrench or ratchet.

Notes:

- Do not remove the center fasteners. This helps to maintain proper spacing during reassembly. They can be used for additional adjustment if needed.
- Ensure removed fasteners are properly stored to prevent loss or incorrect reassembly.

Figure 7. Upper cross brackets

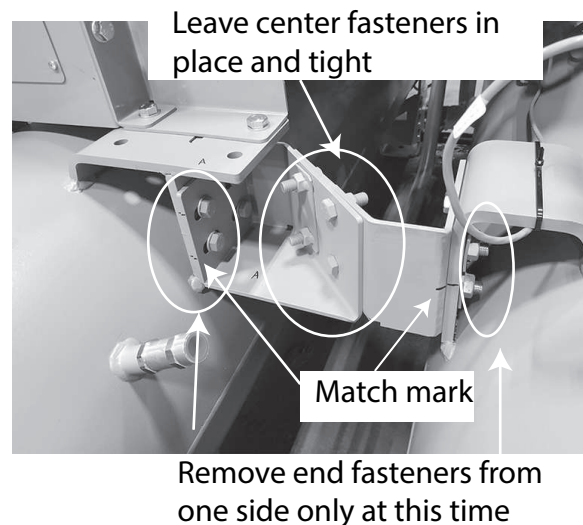
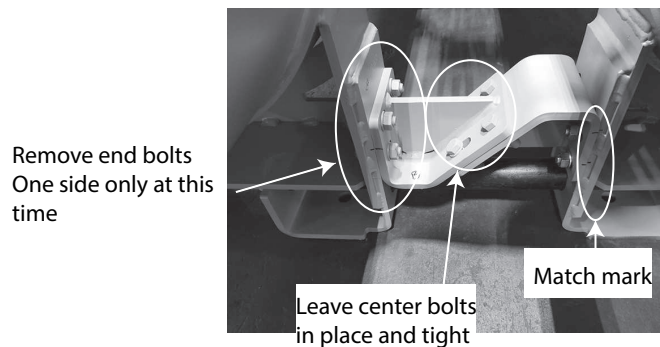

Figure 8. Lower cross brackets



Removing the Motor Terminal Box and Disconnecting the Motor Terminals

⚠ WARNING

Heavy Object!

Failure to follow instructions below could result in unit dropping which could result in death or serious injury, and equipment or property-only damage.

Ensure that all the lifting equipment used is properly rated for the weight of the unit being lifted. Each of the cables (chains or slings), hooks, and shackles used to lift the unit must be capable of supporting the entire weight of the unit. Lifting cables (chains or slings) may not be of the same length. Adjust as necessary for even unit lift.

1. Remove the covers as shown in [Figure 9, p. 10](#).

Tools: 10 mm wrench or ratchet.

Figure 9. Motor terminal covers

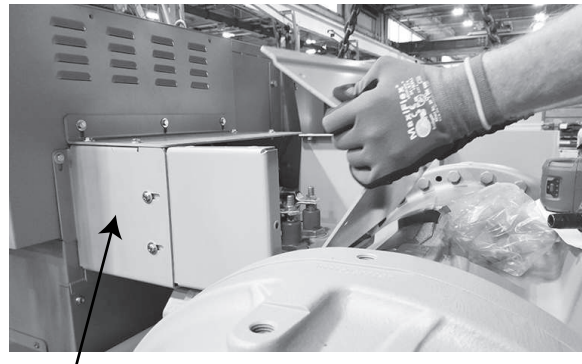

Note: Do not remove at this time.

2. Disconnect the terminals using backing wrench.
3. Disconnect the motor terminal box from the panel box.
Remove the motor terminal box as shown in [Figure 10, p. 10](#).

Tools: (2) 3/4-inch wrenches or wrench and socket.

Figure 10. Removing the motor terminal box.

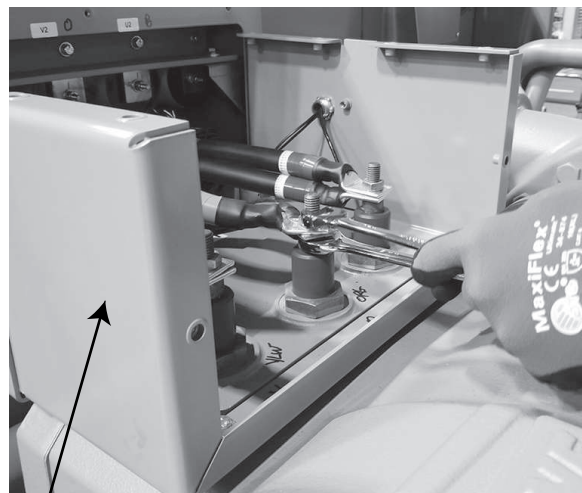

Note: Remove this box and cover

Removing the Check Valve

⚠ WARNING

Heavy Object!

Failure to follow instructions below could result in unit dropping which could result in death or serious injury, and equipment or property-only damage.

Ensure that all the lifting equipment used is properly rated for the weight of the unit being lifted. Each of the cables (chains or slings), hooks, and shackles used to lift the unit must be capable of supporting the entire weight of the unit. Lifting cables (chains or slings) may not be of the same length. Adjust as necessary for even unit lift.

1. Remove the 6 upper studs as shown in [Figure 11, p. 11](#).

Tools: 24 mm wrenches or ratchets, hoist and strap.

2. Loosen the lower 6 studs but do not remove.

Figure 11. Check valve removal



3. Remove the check valve and gaskets.
 - Use a strap and lifting assist.
 - Use care not to damage the internal valve mechanisms.

4. Remove the remaining 6 studs.

Note: *Ensure removed fasteners are properly stored to prevent loss or incorrect reassembly.*

Disconnecting the Global Connectors

1. Disconnect the global bus crossover cable.

Note: *This is the only connector that needs to be disconnected to split unit in half.*

Figure 12. Global connector disconnect

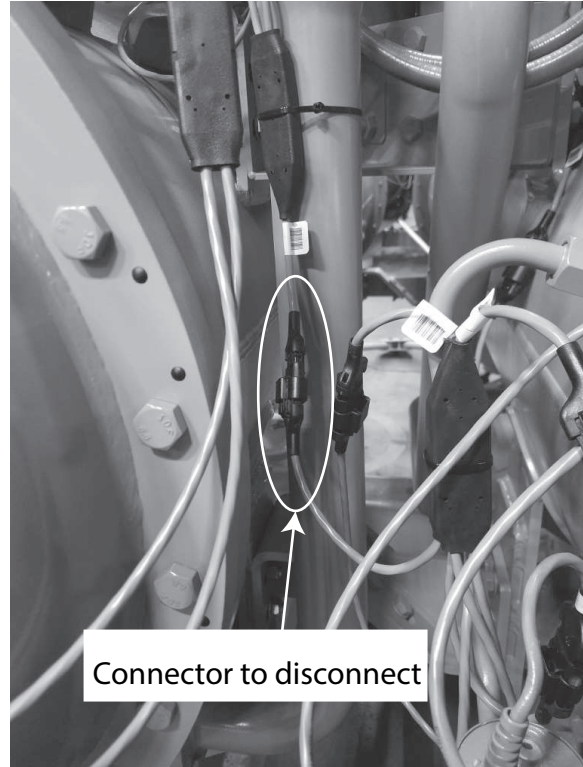

2. Secure all loose cables.

Disconnecting the Condenser Drain Line

⚠ WARNING

Heavy Object!

Failure to follow instructions below could result in unit dropping which could result in death or serious injury, and equipment or property-only damage.

Ensure that all the lifting equipment used is properly rated for the weight of the unit being lifted. Each of the cables (chains or slings), hooks, and shackles used to lift the unit must be capable of supporting the entire weight of the unit. Lifting cables (chains or slings) may not be of the same length. Adjust as necessary for even unit lift.

1. Disconnect the economizer EXV line from the condenser return line. See [Figure 13, p. 13](#).
2. Disconnect the condenser drain line from the economizer by removing the 4 bolts. See [Figure 14, p. 13](#).
3. Ensure removed fasteners are properly stored to prevent loss or incorrect reassembly.

Tools: 19 mm wrench, 1–5/8 wrench, 1–1/2 wrench.

Figure 13. Disconnecting the economizer EXV line from the condenser return line



Figure 14. Disconnecting the condenser drain line from the economizer



Moving the Lifting Brackets to the Common Shell (both ends)

⚠ WARNING

Heavy Object!

Failure to follow instructions below could result in unit dropping which could result in death or serious injury, and equipment or property-only damage.

Ensure that all the lifting equipment used is properly rated for the weight of the unit being lifted. Each of the cables (chains or slings), hooks, and shackles used to lift the unit must be capable of supporting the entire weight of the unit. Lifting cables (chains or slings) may not be of the same length. Adjust as necessary for even unit lift.

1. Remove the bolts securing the lifting bracket and remove the lifting bracket from the unit half not being rigged (both ends) as shown in [Figure 15, p. 14](#).
2. Remove only the bolts needed to install the lifting bracket from waterbox from the unit half being rigged in the location show (both ends) as shown in [Figure 15, p. 14](#).
3. Move lifting bracket to half being rigged as shown and reinstalled hardware (both ends). Torque fasteners to 90 ft/lbs.

Notes:

- *Ensure removed fasteners are properly stored to prevent loss or incorrect reassembly.*
- *The 150 psi waterbox is shown and has 4 bolts per lifting bracket. The 300 psi waterbox has 8 bolts per lifting bracket*

Figure 15. Waterbox bolts

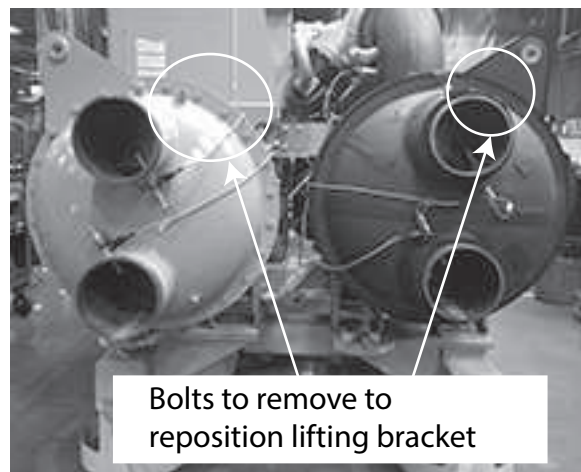

Moving the Lifting Brackets to the Common Shell (both ends)

4. Replace the bolts in the rigging brackets.
Torque to 90 ft/lbs.

Note: *The 150 psi waterbox is shown and has 4 bolts per lifting bracket. The 300 psi waterbox has 8 bolts per lifting bracket.*

Figure 16. Repositioning lifting bracket



Disconnecting the Conduit Connections at the Back of the Electrical Panel

1. Remove the cover from the rear connector panel.
2. Disconnect the conduits at the panel as shown in [Figure 18, p. 16](#).
Not all conduits need to be disconnected at this time.

Figure 17. Rear connector panel cover



Figure 18. Disconnecting the conduits

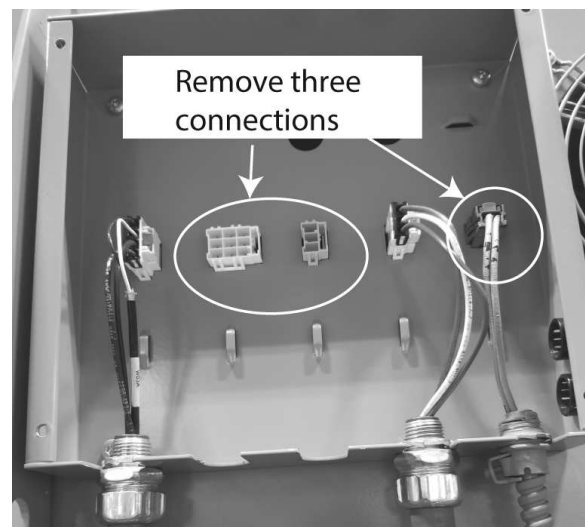

Figure 19. Securing conduits with compressor



NOTICE

Electrostatic Discharge!

Electrostatic discharge can short equipment circuitry. Ensure that you are properly grounded before handling sensitive electronic equipment.

3. Secure the two conduits to the compressor. Secure the high pressure cutout conduit to the compressor discharge pipe.
Do not disconnect the MBC at the compressor.
Tools: screwdriver, tie wraps.

Disconnecting and Plugging the Drive Cooling Lines from the Braze Plate Heat Exchanger (BPHE)

⚠ WARNING

Heavy Object!

Failure to follow instructions below could result in unit dropping which could result in death or serious injury, and equipment or property-only damage.

Ensure that all the lifting equipment used is properly rated for the weight of the unit being lifted. Each of the cables (chains or slings), hooks, and shackles used to lift the unit must be capable of supporting the entire weight of the unit. Lifting cables (chains or slings) may not be of the same length. Adjust as necessary for even unit lift.

Figure 20. Disconnecting the cooling lines



1. Remove the 2 hose clamps at the braze plate heat exchanger as shown in [Figure 20, p. 17](#).
2. Disconnect hoses 1 at a time and insert temporary plugs into ends of hoses (3/4-inch barbed hose plugs) as shown in [Figure 21, p. 17](#).
3. Secure hoses to the back of the drive panel.

Tools:

- 3/4-inch barbed hose plugs
- Pinch clamp pliers
- Pinch clamps or hose clamps (if desired)
- Zip ties

Figure 21. Plugging cooling lines



Separating the Primary Subassemblies

⚠ WARNING

Heavy Object!

Failure to follow instructions below could result in unit dropping which could result in death or serious injury, and equipment or property-only damage.

Ensure that all the lifting equipment used is properly rated for the weight of the unit being lifted. Each of the cables (chains or slings), hooks, and shackles used to lift the unit must be capable of supporting the entire weight of the unit. Lifting cables (chains or slings) may not be of the same length. Adjust as necessary for even unit lift.

Notes:

- Use appropriate hoist, spreader bar shackles, and straps or slings.
- Six ton lifting capability is acceptable. If a more accurate value is required, contact Trane support with specific unit identification.

1. If moving evaporator half, loosely attach an anti-roll strap from the compressor to the spreader bar.

If moving condenser half, loosely attach an anti-roll strap from an AFD lifting point to the spreader bar.

Notes:

- This is not used for lifting, this line should have some slack.
- Rigging points are above the center of gravity; however, this provides some additional protection against tipping the unit over within the rigging.

Figure 22. Evaporator/compressor half



2. Remove the items securing the unit.
 1. Check to confirm any items securing the halves together have been separated.
 2. Check that the half being moved is no longer secured to the floor or the dunnage.
 3. Check that the half remaining stationary is well-secured to prevent tipping during and after separation.

Figure 23. Condenser/AFD half

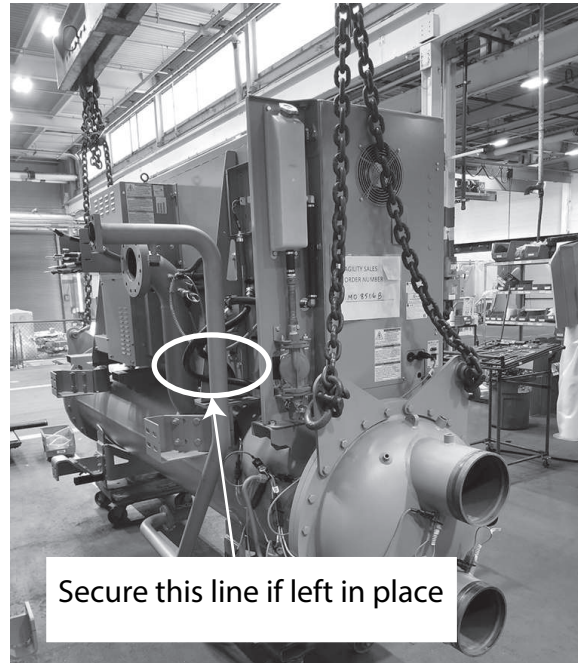

3. Lift the unit slightly, approximately 1/2 inch to ensure proper rigging and separation.

Tools: (4) 1 in.-10T shackles, (1–4) M16 swivel “D” rings, chains or straps, spreader bar.

The unit can now be separated for movement or to provide easier access for further disassembly.

Transferring One Half to the New Location and Securing

⚠ WARNING

Heavy Object!

Failure to follow instructions below could result in unit dropping which could result in death or serious injury, and equipment or property-only damage.

Ensure that all the lifting equipment used is properly rated for the weight of the unit being lifted. Each of the cables (chains or slings), hooks, and shackles used to lift the unit must be capable of supporting the entire weight of the unit. Lifting cables (chains or slings) may not be of the same length. Adjust as necessary for even unit lift.

Figure 24. Securing condenser liquid line

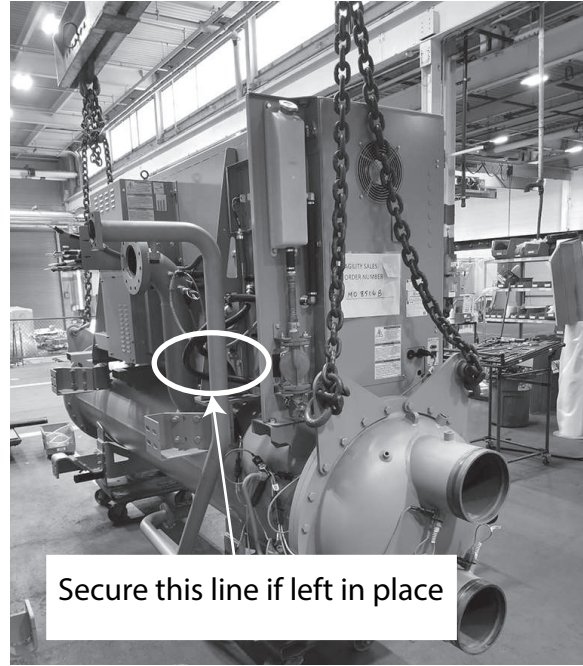

Note: If installing the unit in halves, complete the following steps:

1. Secure the condenser liquid line to the discharge pipe or condenser cross bracket to prevent damage as shown in [Figure 24, p. 20](#).
2. Replace the motor terminal box cover to protect the motor terminals as shown in [Figure 25, p. 20](#).

Note: If further disassembly is required, additional items can now be removed to further reduce the envelope of the unit.

Figure 25. Replacing the motor terminal box cover

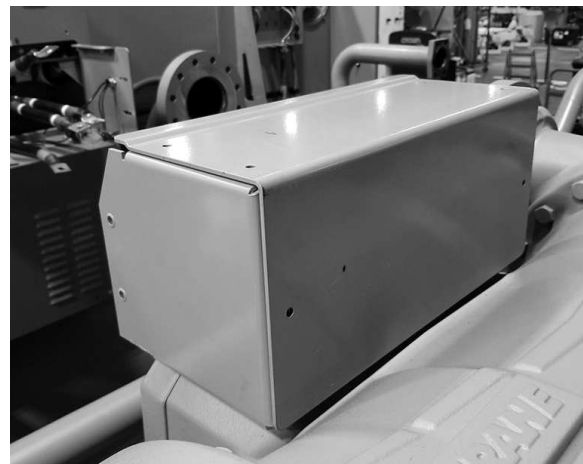

Additional Disassembly

Note: The following sections describe disassembly of additional components or sub-assemblies. These procedures are to be performed as needed depending on the application.

Removing the Cross-tie Brackets

1. Removing the cross-tie brackets (16) 16 mm bolts.

Tools: 24 mm wrench or ratchet.

Figure 26. Removing cross-tie brackets



Removing the Condenser Liquid Line

1. Remove the condenser drain line, (4) 12 mm bolts.

Tools: 19 mm wrench or ratchet.

Figure 27. Removing the condenser liquid line



Removing the Condenser Discharge Pipe

1. Remove the condenser discharge pipe, (8) 12 mm bolts.

Tools: 19 mm wrench or ratchet, lifting strap.

Note: Use caution to not damage pressure sensor or high pressure cutout switch on pipe during removal of pipe.

Figure 28. Removing the condenser discharge pipe

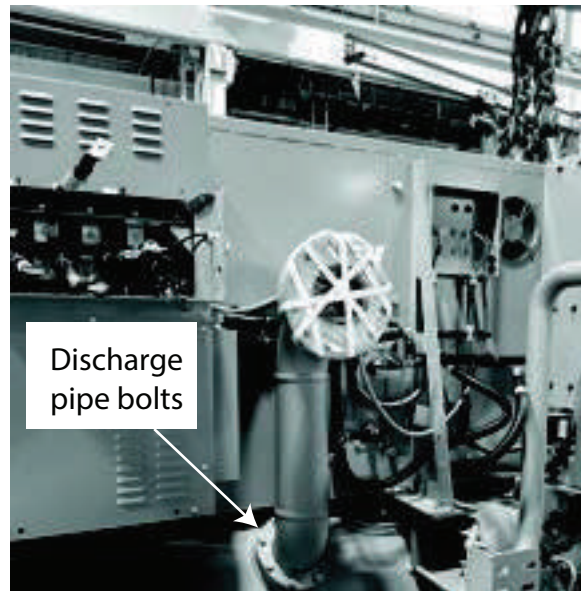

Removing the Motor Terminal Box

1. Remove the remaining control panel motor terminal cover, seven 6 mm bolts. See [Figure 29, p. 23](#).

The conduit does not need to be removed. The cover can be placed along side the output filter and secured.

Tools: 10 mm wrench or ratchet, zip ties.

2. Disconnect PT wiring by disconnecting spade connections. Disconnect the thermister switch on top of the inductor (if equipped) using a screw driver. See [Figure 30, p. 23](#). For units not equipped with an output inductor, the thermister switch wires are terminated with a lever nut. In this case, clip the wire tie holding them to the side of the transition box. See [Figure 31, p. 23](#)
3. Disconnect the conduit fitting from the enclosure and secure conduit to back panel.
4. Remove remaining enclosure, three 6 mm bolts. See [Figure 29, p. 23](#).

Figure 29. Removing control panel terminal box

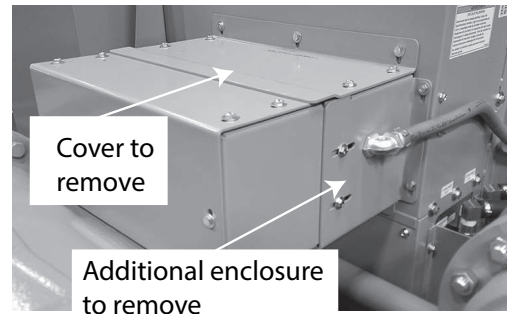

Figure 30. PT and thermister wiring

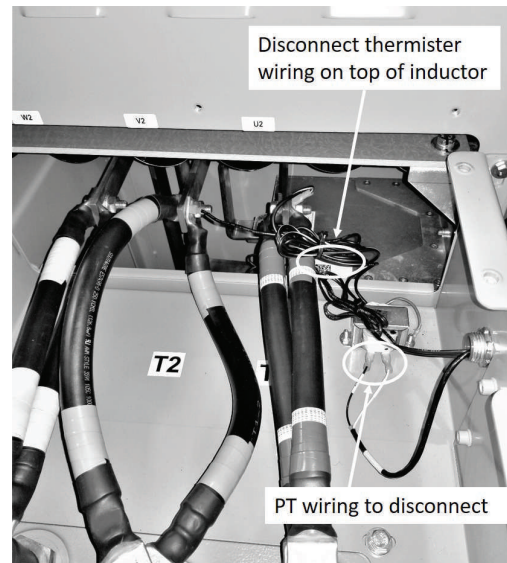
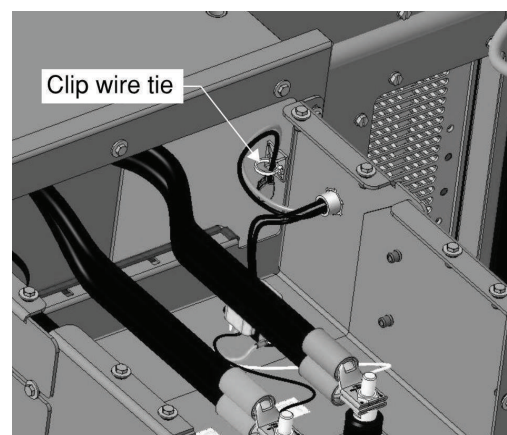

Figure 31. Wire tie clip



Removing the Evaporator Main EXV Line

1. Remove the evaporator main EXV line (8) 12 mm bolts.
See [Figure 32, p. 24](#).

Tools: 19 mm wrench or ratchet, 1.5 inch wrench.

Figure 32. Main evaporator EXV line

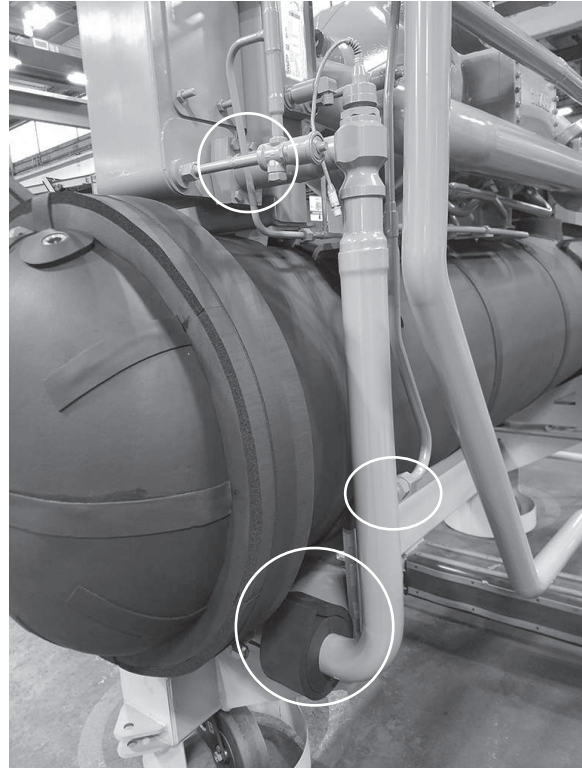

Removing the Economizer to Compressor Line

1. Remove the economizer to compressor line (8) 12 mm bolts. See [Figure 33, p. 25](#)

Tools: 19 mm wrench.

Figure 33. Economizer to compressor line

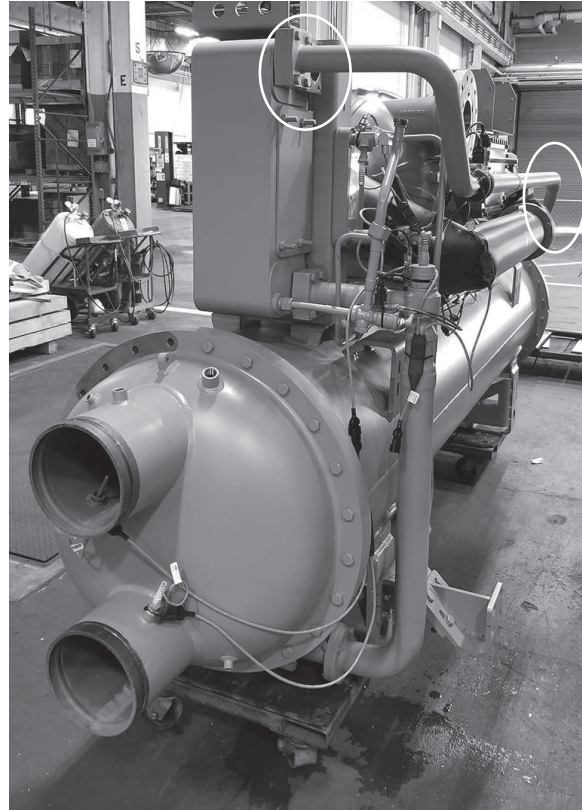

Removing the Compressor Interstage Line

1. Remove the compressor interstage (18) 16 mm bolts. See [Figure 34, p. 25](#).

Tools: 24 mm wrench or ratchet.

Figure 34. Compressor interstage line

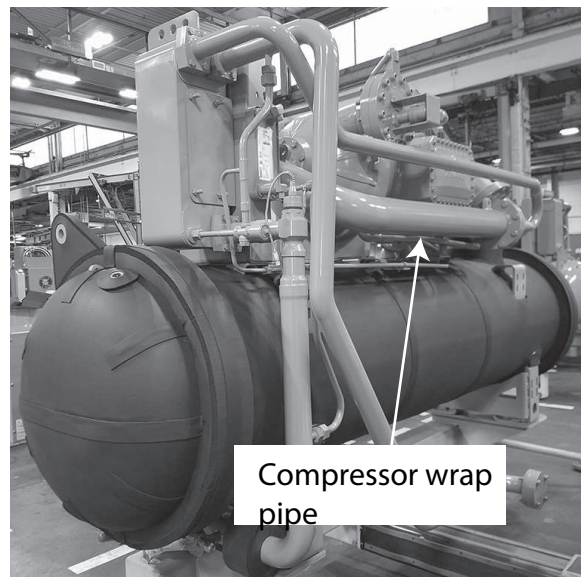

Removing the Condenser Liquid Level Sensor

1. Remove the condenser liquid level sensor (2) 8 mm bolts, (2) Fittings.

Tools: 1.125 wrench. See [Figure 35, p. 26](#) and [Figure 36, p. 26](#), 13 mm wrench or ratchet.

Figure 35. Removing the liquid level sensor (hardware)

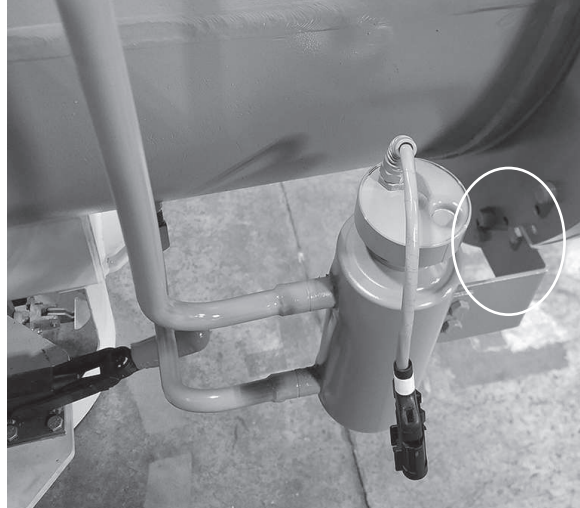

Figure 36. Removing the liquid level sensor (fittings)



Removing the Options Panel (if present)

1. If the options panel is present remove the top panel shear plate. (6) 16 mm bolts as shown in [Figure 37, p. 27](#).

Tools: 24 mm wrench or ratchet.

Figure 37. Shear plate bolts and rigging hole

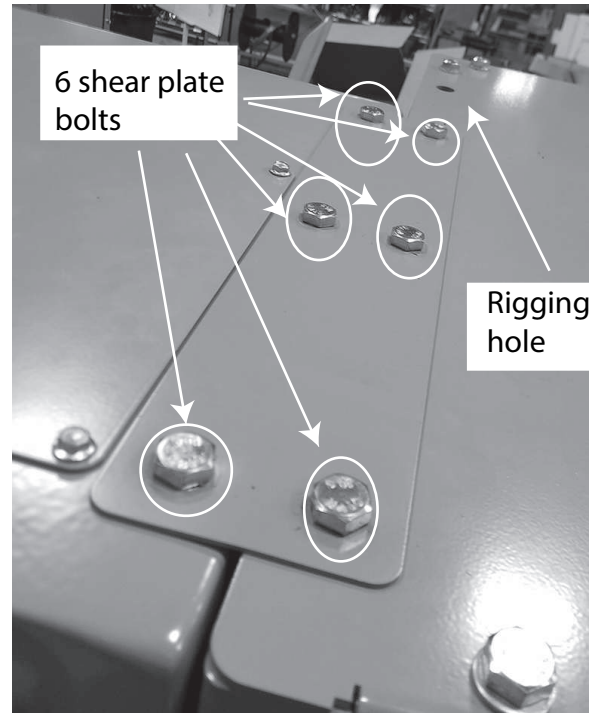

2. Secure the options panel to the overhead lifting device as shown in [Figure 38, p. 27](#).

Tools: (4) 16 mm swivel "D" rings and shackles or straps.

Figure 38. Rigging holes

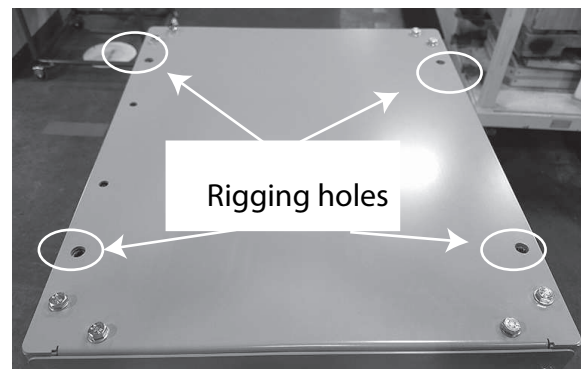

3. Disconnect the internal wiring between the main and option panels. Wiring will vary depending upon the options package.

Note: This includes main power, fan power, and possible control wiring. Mark wires as removed to ensure proper reassembly.

Additional Disassembly

4. Remove the (6) 16 mm base bolts as shown in [Figure 39, p. 28](#).

Tools: 24 mm wrench or ratchet.

Figure 39. Removing base bolts



⚠ WARNING

Heavy Objects!

Failure to follow these instructions could result in death, serious injury, and property damage.

Always lift the options panel and the control panel separately. NEVER lift them together as it could cause them to come crashing down.

5. The options panel can now be removed using four lifting points on top of the panel.

Figure 40. Removing the options panel

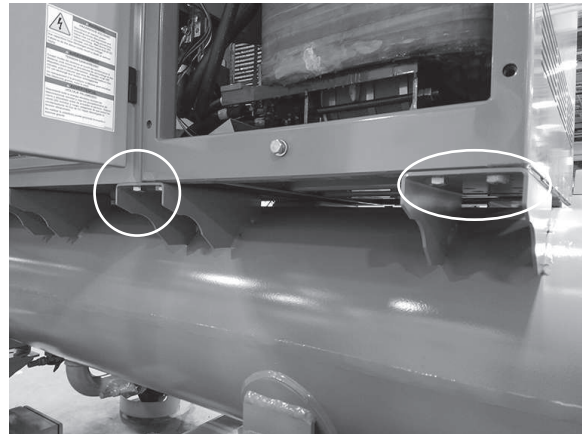

Removing the Drive Panel

1. Secure the main AFD panel to the overhead lifting device.

Figure 41. Lifting locations for the control panel



2. Lifting locations for control panel as shown in [Figure 41, p. 29](#).

Tools: (4) M16 swivel “D” rings, chains or straps.

Additional Disassembly

3. Remove the (6) 16 mm bolts from the front of the base of the main AFD panel as shown in [Figure 42, p. 30](#).

Tools: 24 mm wrench or ratchet.

Figure 42. AFD front fasteners



- Remove the (6) 16 mm bolts from the brackets at the rear base of the main panel as shown in [Figure 43, p. 31](#).

Tools: 24 mm wrench or ratchet.

Figure 43. AFD rear fasteners

Leave rear brackets in place
(move with main panel)

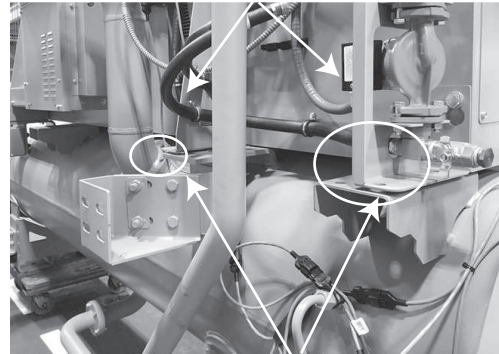

Fastener locations in rear of
AFD main panel back brackets
(do not remove back brackets
from AFD)

- The brackets should not be removed from the back of the panel.

The main panel can now be removed.

Tools: (4) 16 mm swivel "D-rings, shackles and straps or chains.

Removing the Compressor

- The height of the evaporator can be reduced by removing the compressor and economizer. Disconnect the motor cooling lines from the compressor as shown in [Figure 44, p. 31](#). Leave them attached to the economizer.

Tools: 1.875 inch wrench.

Figure 44. Compressor cooling line removal

Cooling lines

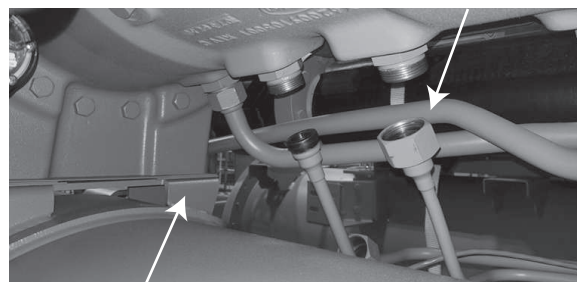

Compressor mounting bolts

Additional Disassembly

2. If not already removed, remove four M12 bolts securing economizer to compressor second stage piping. This pipe may be left attached to the compressor and secured with block and strap as shown in [Figure 45, p. 32](#) and [Figure 46, p. 32](#).

Figure 45. Disconnecting economizer to compressor line from economizer



Figure 46. Securing economizer line to compressor

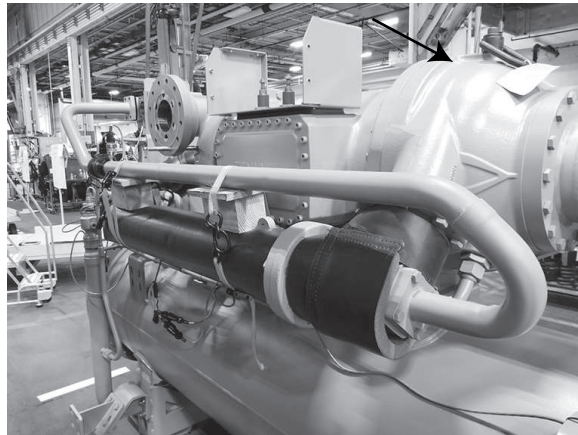

3. Disconnect the pressure sensor on suction elbow and remove (12) M12 bolts securing the base of the suction elbow in [Figure 47, p. 33](#) and [Figure 48, p. 33](#).

Note: *It is recommended to leave the suction elbow attached to the compressor and remove the compressor/suction elbow as an assembly.*

Figure 47. Disconnecting pressure sensor



Figure 48. Removing suction elbow



Additional Disassembly

4. Attach the compressor to the overhead lifting device as shown in [Figure 49](#), p. 34.

Tools: (2) 16 mm swivel "D rings, shackles, straps or chains.

Figure 49. Attaching rigging to compressor



5. Tape any compressor base shims in place as shown in [Figure 50](#), p. 34.

Tools: Tape.

Figure 50. Compressor base shims

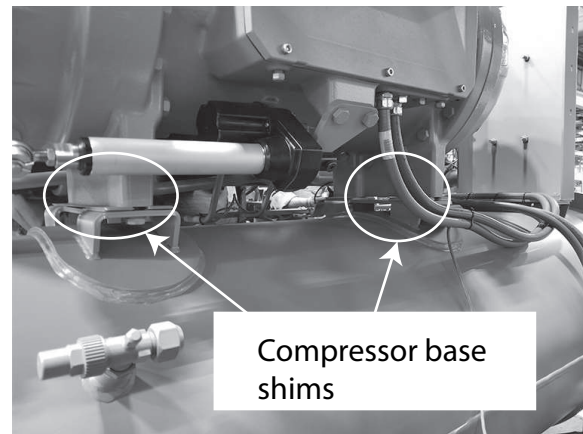

6. Remove the (4) 16 mm bolts from the compressor base. The compressor can now be removed from the unit.

Tools: 24 mm wrench or ratchet.

7. Block the compressor as shown in [Figure 51](#), p. 34 to prevent damage to the suction elbow.

Figure 51. Blocking the compressor

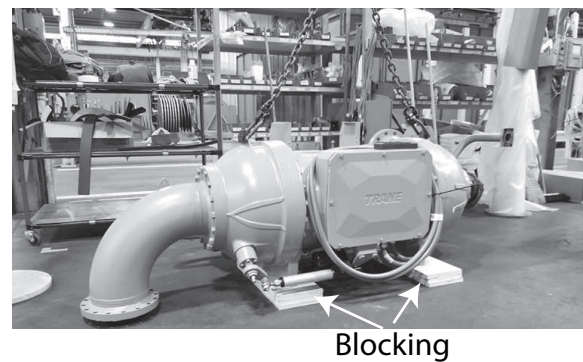

8. Cover openings. Secure cover to prevent it from being pulled into the unit as shown in [Figure 52, p. 35](#) and [Figure 53, p. 35](#).

Figure 52. Covering openings**Figure 53. Securing cover**

Removing the Economizer

1. Attach rigging to the lifting point at the top of the economizer mounting bracket.
2. If water flow control (WFC) option is installed, disconnect the tubing at waterboxes and coil onto sensor bracket. Leave WFC sensor assembly attached to the economizer. Remove the two 16 mm bolts and the base.

Additional Disassembly

3. Remove the clamps or ties securing the motor cooling lines to the unit. Support the lines during removal of the economizer.

Note: Lift the economizer and set aside.

Figure 54. Unbolting the economizer 2



4. Unbolt the economizer.

Figure 55. Unbolting the economizer 1

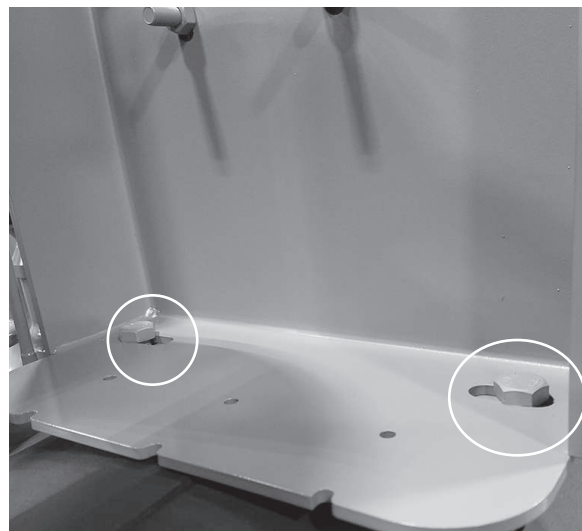

5. Lift the economizer using lift points as shown in [Figure 56, p. 37](#).

Figure 56. Economizer lift points

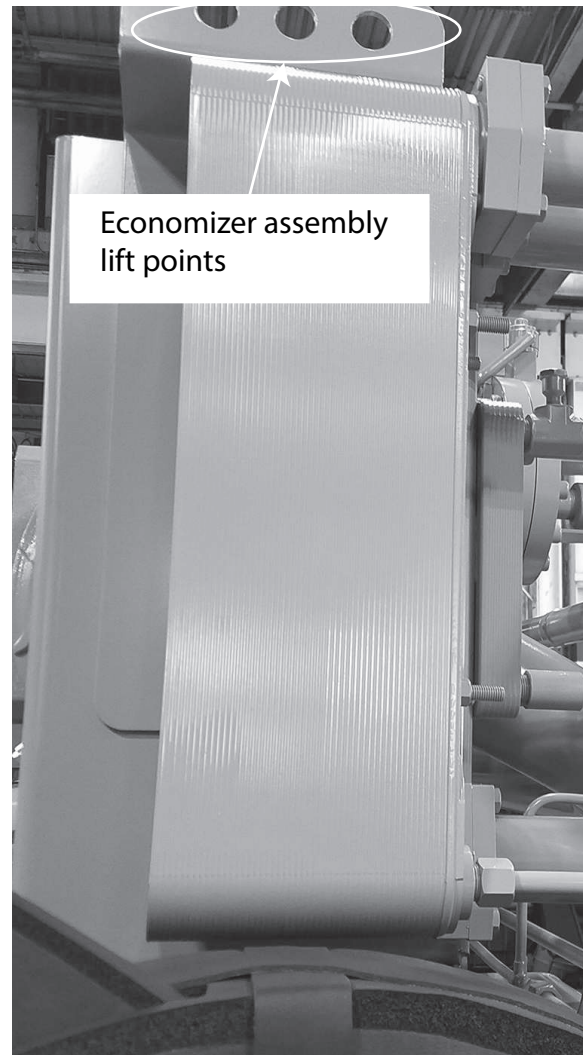

6. The economizer subassembly can now be removed.
Further disassembly is possible but the unit is now at its minimum dimensions.
Tools: Tape, zip ties, straps, 24 mm wrench or ratchet.

Reassembly Instructions for HDWA

⚠ WARNING

Heavy Object!

Failure to follow instructions below could result in unit dropping which could result in death or serious injury, and equipment or property-only damage.

Ensure that all the lifting equipment used is properly rated for the weight of the unit being lifted. Each of the cables (chains or slings), hooks, and shackles used to lift the unit must be capable of supporting the entire weight of the unit. Lifting cables (chains or slings) may not be of the same length. Adjust as necessary for even unit lift.

Important:

- Reassembly is the reverse of disassembly.
- The unit is intended to be assembled in halves, condenser and evaporator, then assembled as a complete unit.
- Sufficient clearance is designed into the unit such that doweling and pinning is unnecessary and potentially detrimental. The assembly should be fitted loose until all piping for the "half" is installed then the "half" can be tightened. Only a few components cross over between "halves"; the condenser drain, the compressor discharge pipe, the cross tie brackets, global bus connector, HUBA hoses and wiring (if present), and the motor cooling glycol lines. Since reassembly is primarily the reverse of disassembly for the "halves" Fitting the compressor discharge pipe, condenser drain line and the cross tie brackets are what the reassembly should focus on.

Reinstall drive cooling hoses using new pinch clamps. Traditional hose clamps are also acceptable. Refill the coolant from the reservoir. Refer to the *Agility Service Guide*, HDWA SVG001*-EN for the glycol fill procedure.

Installation Instructions for Non-Marine Waterbox Hinge Assembly

Figure 57. Non-marine waterbox hinge assembly

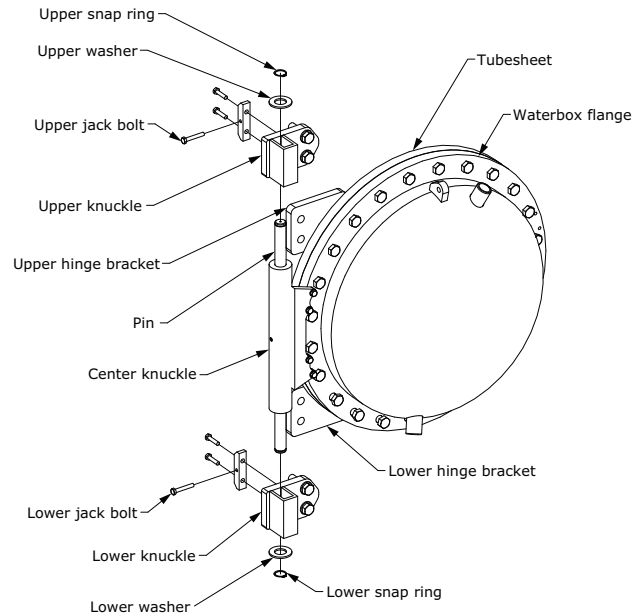

1. Install each (lower and upper) hinge bracket to tubesheet with three M8 X 35 mm bolts as shown in the following figure. (See the following table for torque values.)

Figure 58. Installing hinge bracket to waterbox

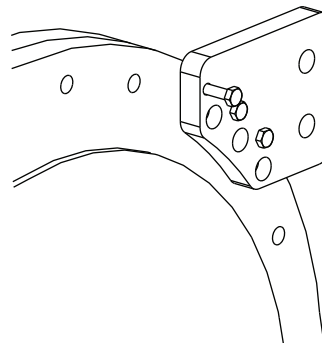

Table 2. Torque details

Part Numbers Descriptions Torque	Descriptions	Torque
X25030215070	SCREW; M8 HEX CAP, M8 X 35 MM	19 +/- 1 ft-lb
X25030215050	SCREW; M8 X 25 MM, HEX CAP	19 +/- 1 ft-lb

Table 2. Torque details (continued)

Part Numbers Descriptions Torque	Descriptions	Torque
X25030218090	SCREW; M16 X 60 MM, HEX CAP	163 +/- 10 ft-lb
X25030215100	SCREW; M8 X 50 MM, HEX CAP	19 +/- 1 ft-lb

- Move hinge assembly into position. See the following figure. Install all fasteners for the hinge assembly but keep loose. Torque sequence is shown in the following steps. See [Table 2, p. 38](#) for torque values.

Figure 59. Installing the fasteners for the hinge assembly

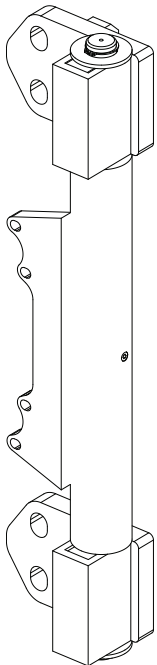

- Torque center knuckle of hinge to waterbox flange with M8 X 25 mm bolt and washer as shown in below figure. See [Table 2, p. 38](#) for torque values.

Figure 60. Torque center knuckle of hinge

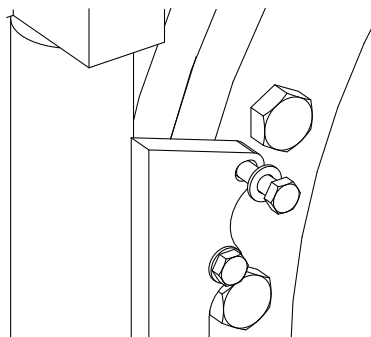

- Lift the hinge lower knuckle to contact the center

knuckle and torque the M16 X 90 mm bolts and nuts with washers on both sides as shown in the following figure. See [Table 2, p. 38](#) for torque values.

Note: Ensure the Jackbolt is not contacting the hinge bracket, if it is back out the Jackbolt.

Figure 61. Jackbolt not contacting the hinge bracket

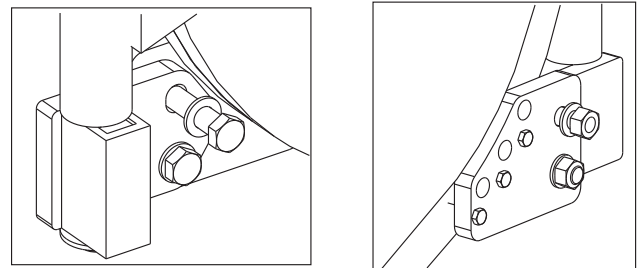

Note: Ensure the minimum gap is no greater than 0.005 inch gap or less after tightening the fasteners between center knuckle and lower knuckle as shown in the following figure.

Figure 62. Minimum gap between center knuckle and lower knuckle

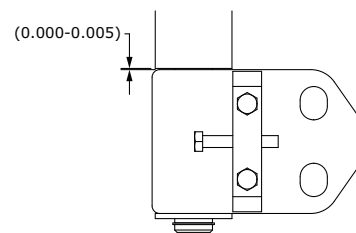

- Lift the hinge upper knuckle until it contacts the upper washer.
- Tighten the jack bolt M8 X 50 mm of upper knuckle.

Figure 63. Tightening the jack bolt

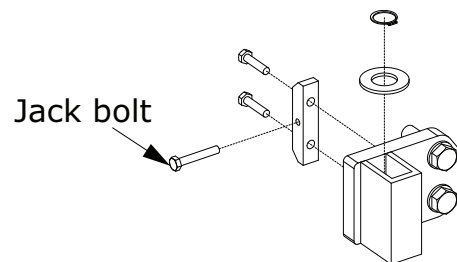

- Ensure jack bolt is tightened as mentioned in previous step and torque the M16 X 90 mm bolts and nuts with washers on both sides. See [Table 2, p. 38](#) for torque values.

Note: Ensure 0.005 inch gap or less after tightening the fasteners between upper knuckle and upper washer as shown in the following figure.

Figure 64. Tightening the fasteners between upper knuckle and upper washer

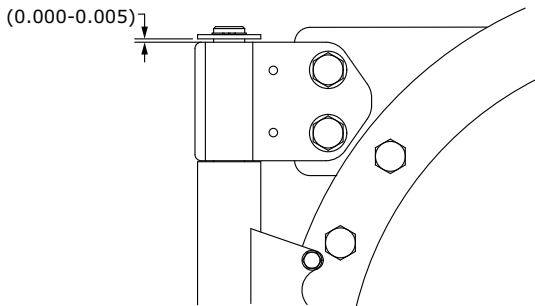

Installation Instructions for Marine Waterbox Hinge Assembly

Figure 65. Marine waterbox hinge assembly

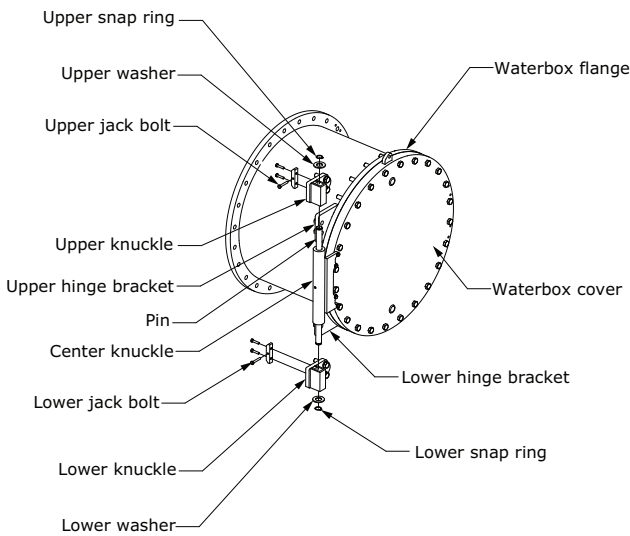

1. Install each (lower and upper) Hinge Bracket to waterbox flange with three M8 X 35 mm bolts as shown in the following figure. See [Table 2, p. 38](#) for torque values.

Figure 66. Installing hinge bracket to waterbox

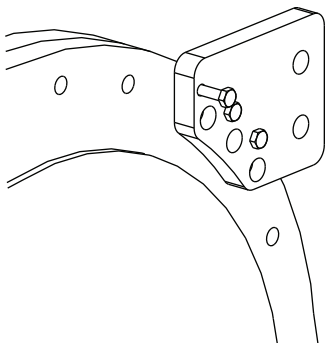

2. Move Hinge assembly into position. See the following

figure. Install all fasteners for the hinge assembly but keep loose. Torque sequence is shown in the following steps. See [Table 2, p. 38](#) for torque values.

Figure 67. Installing the fasteners for the hinge assembly

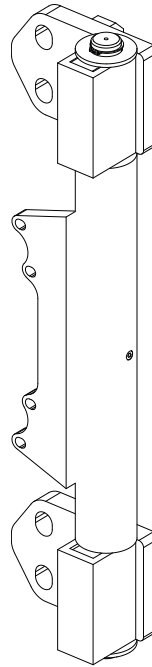

3. Torque center knuckle of hinge to waterbox cover with M8 X 25 mm bolt and washer as shown in below figure. See [Table 2, p. 38](#) for torque values.

Figure 68. Torque center knuckle of hinge

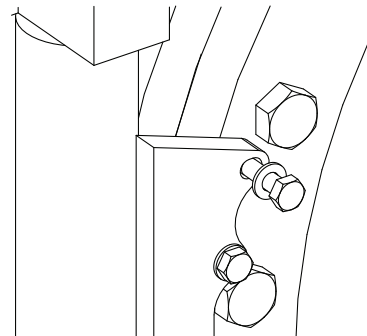

4. Lift the hinge lower knuckle to contact the center knuckle and torque the M16 X 90 mm bolts and nuts with washers on both sides as shown in below figure. See [Table 2, p. 38](#) for torque values.

Note: Ensure the Jackbolt is not contacting the Hinge bracket, if it is back out the Jackbolt.

Figure 69. Jackbolt not contacting the hinge bracket

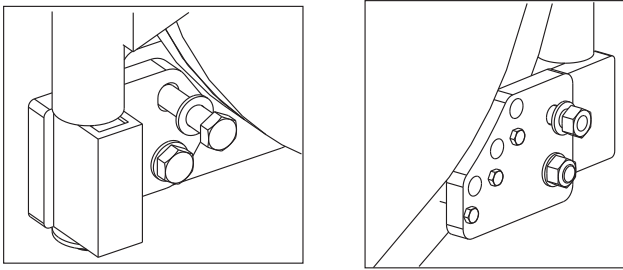

Note: Ensure the minimum gap is no greater than 0.005 inch gap or less after tightening the fasteners between center knuckle and lower knuckle as shown in [Figure 62, p. 39](#).

5. Lift the hinge upper knuckle until it contacts the upper washer.
6. Tighten the Jack bolt M8 X 50 mm of upper knuckle. See [Table 2, p. 38](#) for torque values.

Figure 70. Tightening the jack bolt

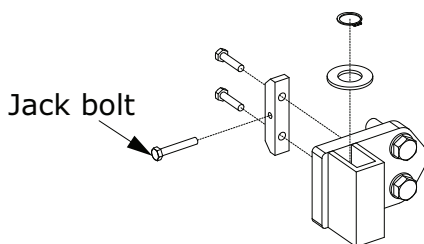

7. Ensure jack bolt is tightened as mentioned in previous step and torque the M16 X 90 mm bolts and nuts with washers on both sides. See [Table 2, p. 38](#) for torque values.

Note: Ensure 0.005 inch gap or less after tightening the fasteners between upper knuckle and upper washer as shown in [Figure 64, p. 40](#).

Disassembly Instructions Marine and Non-Marine Waterboxes

⚠ WARNING

Heavy Object!

Failure to follow instructions below could result in unit dropping which could result in death or serious injury, and equipment or property-only damage.

Ensure that all the lifting equipment used is properly rated for the weight of the unit being lifted. Each of the cables (chains or slings), hooks, and shackles used to lift the unit must be capable of supporting the entire weight of the unit. Lifting cables (chains or slings) may not be of the same length. Adjust as necessary for even unit lift.

The following instructions shows how to disassemble either marine or non-marine waterboxes:

1. Handle with care, the hinge weight is 44 lbs.
2. Loosen the jack bolt M8 X 50 mm of upper knuckle.
3. Loosen the M16 fasteners of upper knuckle.
4. Loosen the M16 fasteners of lower knuckle.
5. Ensure the complete weight is supported, and carefully remove the M8 fasteners of center knuckle.
6. If necessary, remove hinge brackets (top and bottom) from tube sheet by loosening the M8 fasteners.

Figure 71. Non-marine waterbox hinge

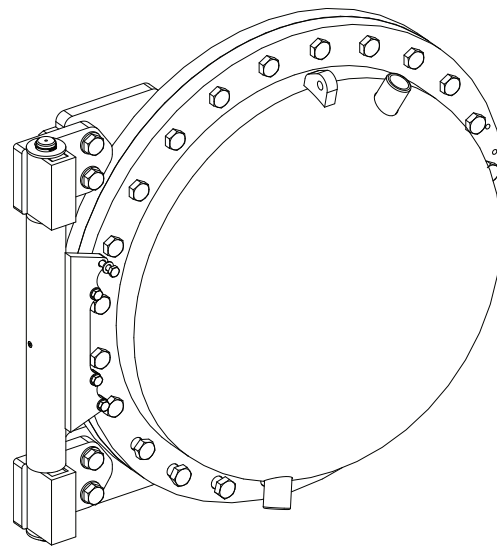
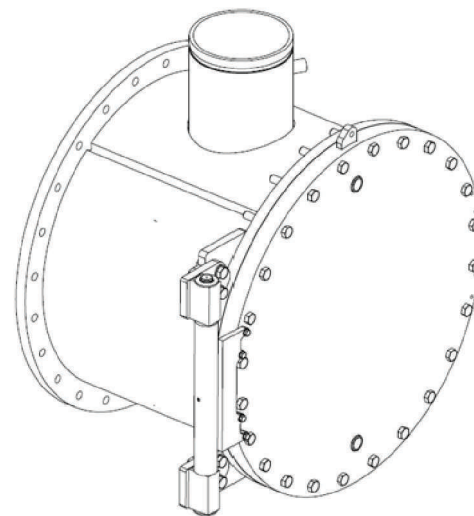

Figure 72. Marine waterbox hinge





Appendix A : Tools, Weights, Lubrication, Torques

Table 3. Torque chart

Application	Thread/Size	Torque (Dry unless otherwise specified)		Wrench Size	Notes
		ft-lb (UOS)	N-m		
Electrical Terminals	3/8 in. -16 UNC	132-156	15-18	9/16 inch	Use of a backing wrench is recommended
	1/2 in. -13 UNC	18-22	24-30	3/4 inch	
	5/8 in. -11 UNC	32-36	43-49	15/16 inch	
O-Ring Face Seal Tube Fittings SAE J1453 Steel Fittings Only	4	18-20	24-27	11/16 inch	Use of a backing wrench, where applicable, is recommended O-ring to be lubricated with grease or oil compatible with the refrigerant in use. If threads are lubricated reduce torque value by 25%.
	6	29-31	40-44	13/16 inch	
	8	38-42	52-57	15/16 inch	
	10	60-66	82-90	1-1/8 inch	
	12	85-95	115-126	1-3/8 inch	
	16	110-122	149-164	1-5/8 inch	
	20	153-167	207-228	1-7/8 inch	
	24	230-254	312-343	2-1/4 inch	
Grade 8.8 Metric Fasteners	M5-0.8	54-66 (in-lb)	6-8	8 mm	If threads are lubricated reduce torque value by 25%.
	M6-1.0	86-105 (in-lb)	10-12	10 mm	
	M8-1.25	17-21	23-28	13 mm	
	M10-1.5	34-42	46-57	16 mm	
	M12-1.75	60-72	81-98	19 mm	
	M14-2.0	95-115	129-156	21 mm	
	M16-2.0	148-180	200-244	24 mm	
	M18-2.5	203-247	275-335	30 mm	
	M20-2.5	288-348	390-472	36 mm	

Table 4. Wrench and sockets

Size	Notes
3/4 inch	Motor terminal wiring (recommended)
9/16 inch	Water flow control tubing
1-1/8 inch	Open ended wrench and "crow's foot for torque wrench, SAE tube fittings, refrigerant fill fittings.
1-1/2 inch	
1-7/8 inch	
10 mm	Motor terminal cover
13 mm	Liquid level sensor
16 mm	Water flow control fitting
19 mm	Suction elbow, discharge pipe
24 mm	Multiple - the majority of fasteners this size. Some joints require 2.

Appendix A : Tools, Weights, Lubrication, Torques

Table 5. Torque wrenches

Imperial (ft-lb)	SI (n-m)
40-200 (in-lb)	4-25
20-100	25-135
50-250	65-350

Table 6. Rigging

Rigging	Notes
(4) 2 in. X 72 in. SCHD 40 pipes	Tip over insurance while separated. Alignment during reassembly.
(4) M16 heavy duty swivel hoist rings	Drive, options panel, and compressor lifting #4000 capacity
(4) 10 ton rigging shackles	Unit lifting
Lifting straps or chains	Capacity dependent upon specific unit and rigging configuration
Spreader bar	Capacity dependent upon specific unit and rigging configuration

Table 7. Miscellaneous

Misc.	Notes
Large adjustable wrenches	Can be used in place of the large open ended wrenches
Breaker bars	Large impact (250 ft-lb) is helpful
Ratchet	Small battery impact is helpful
Screwdrivers	Small electrical components
Pinch bar	Align parts during reassembly
Pinch clamp tool	Remove and reinstall drive cooling hoses
5 gallon bucket	Draining the drive cooling system
Large zip lock bags	Storing fasteners
Painter's masking tape	Secure compressor shims and other parts during separation
Large garbage bags	Covering openings
12 in. zip ties	Secure parts during separation
Permanent marker or china marker	Match marking assemblies and bags of fasteners
Oil or grease compatible with the refrigerant	O-Ring lubrication
Separation gasket kit	Shipped with the unit if ordered as separable
1-1/8 in. Pinch Clamps	Other clamp styles compatible with barbed fittings are acceptable.



Appendix A : Tools, Weights, Lubrication, Torques

Table 8. Half unit split weight

Shell side	Shell size (CDSZ or EVSZ)	Weight range		Weight range	
		Min (lb)	Max (lb)	Min (kg)	Max (kg)
Condenser	020A	4296	8098	1953	3681
Condenser	040A	5640	10481	2563	4764
Evaporator	020A	5549	5601	2522	2546
Evaporator	040A	6834	8055	3106	3661

Notes:

- Weight varies significantly with configuration and degree of disassembly. if a more accurate estimation is needed, use the combined weights from the tables. Evaporator weight includes compressor.
- Condenser half weight includes main drive panel.

Table 9. Shell weight

Shell type	Shell size (CDSZ or EVSZ)	Bundle (CDBS or EVBS)	Weight	
			lb	kg
Condenser	020A	A	2290	1041
Condenser	020A	B	2188	995
Condenser	020A	C	2088	949
Condenser	040A	A	3582	1628
Condenser	040A	B	3374	1534
Condenser	040A	C	3176	1444
Evaporator	020A	A	1997	908
Evaporator	020A	B	1945	884
Evaporator	040A	A	2917	1326
Evaporator	040A	B	2794	1270
Evaporator	040A	C	2687	1221
Evaporator	040A	D	2593	1179
Evaporator	040A	E	2496	1135

Table 10. Economizer

Evaporator size (EVSZ)	Weight	
	lb	kg
020A	143	65
040A	179	81

Table 11. Compressor

NTON	Weight	
	lb	kg
200	2638	1199
300-400	3057	1390

Table 12. Suction elbow

Evaporator shell (EVSZ)	Weight	
	lb	kg
020A	95	43
040A	111	50

Table 13. Control panel

Voltage	SRRL	Weight	
		lb	kg
208	238-440	3802	1728
380-480	238-440	1808	822
380-480	532	1508	685
380-480	675	2310	1050
575-600	238-440	3352	1524
575-600	532	3073	1397
575-600	675	3861	1755

Table 14. Options panel

Volt	SRRL	Weight	
		lb	kg
380-480	238-363	726	330
380-480	439-533	777	353
380-480	675	1247	567
575-600	238-440	700	318
575-600	532-675	1000	454
208	238-363	1600	726
208	362-440	1600	726

Table 15. Small piping wiring, etc

Evaporator size (EVSZ)	Weight	
	lb	kg
020A	870	395
040A	1185	539

Table 16. Water boxes

Shell size (CDSZ or EVSZ)	Shell	Head	Weight	
			lb	kg
020A	Either	Return	98	45
020A	Condenser	Non-marine supply	167	76
020A	Evaporator	Non-marine supply	195	89
020A	Either	Marine supply	358	165
020A	Either	Marine cover	253	162



Appendix A : Tools, Weights, Lubrication, Torques

Table 16. Water boxes (continued)

Shell size (CDSZ or EVSZ)	Shell	Head	Weight	
			lb	kg
040A	Either	Return	148	67
040A	Condenser	Non-marine supply	215	98
040A	Evaporator	Non-marine supply	250	114
040A	Either	Marine supply	659	300
040A	Either	Marine cover	395	179

Table 17. Drive cooling fluid

SRRL	NTON	gal	L
243 to 362	200	1.3	4.9
238 to 532	300/400	1.0	3.8
675	400	1.4	5.3

Trane - by Trane Technologies (NYSE: TT), a global innovator - creates comfortable, energy efficient indoor environments for commercial and residential applications. For more information, please visit trane.com or tranetechnologies.com.

Trane has a policy of continuous product and product data improvements and reserves the right to change design and specifications without notice. We are committed to using environmentally conscious print practices.

HDWA-SVN003B-EN 30 Nov 2022
Supersedes HDWA-SVN003A-EN (April 2021)

©2022 Trane