



## Installation Instructions

# Four-Inch Combustion Air Inlet Kit

Tubular Gas-Fired Direct Spark Propeller Unit Heaters

Category III Venting for Separated Combustion for 30,000 to 75,000 Btu/h

Supplemental to *Operation, Installation, and Maintenance* manual GTNE-SVX001\*-EN.

J30-09406

### SAFETY WARNING

Only qualified personnel should install and service the equipment. The installation, starting up, and servicing of heating, ventilating, and air-conditioning equipment can be hazardous and requires specific knowledge and training. Improperly installed, adjusted or altered equipment by an unqualified person could result in death or serious injury. When working on the equipment, observe all precautions in the literature and on the tags, stickers, and labels that are attached to the equipment.

August 2020

GTNE-SVN002C-EN

TRANE  
TECHNOLOGIES



# Introduction

Read this manual thoroughly before operating or servicing this unit.

## Warnings, Cautions, and Notices

Safety advisories appear throughout this manual as required. Your personal safety and the proper operation of this machine depend upon the strict observance of these precautions.

The three types of advisories are defined as follows:

**⚠ WARNING** Indicates a potentially hazardous situation which, if not avoided, could result in death or serious injury.

**⚠ CAUTION** Indicates a potentially hazardous situation which, if not avoided, could result in minor or moderate injury. It could also be used to alert against unsafe practices.

**NOTICE** Indicates a situation that could result in equipment or property-damage only accidents.

## Important Environmental Concerns

Scientific research has shown that certain man-made chemicals can affect the earth's naturally occurring stratospheric ozone layer when released to the atmosphere. In particular, several of the identified chemicals that may affect the ozone layer are refrigerants that contain Chlorine, Fluorine and Carbon (CFCs) and those containing Hydrogen, Chlorine, Fluorine and Carbon (HCFCs). Not all refrigerants containing these compounds have the same potential impact to the environment. Trane advocates the responsible handling of all refrigerants-including industry replacements for CFCs and HCFCs such as saturated or unsaturated HFCs and HCFCs.

## Important Responsible Refrigerant Practices

Trane believes that responsible refrigerant practices are important to the environment, our customers, and the air conditioning industry. All technicians who handle refrigerants must be certified according to local rules. For the USA, the Federal Clean Air Act (Section 608) sets forth the requirements for handling, reclaiming, recovering and recycling of certain refrigerants and the equipment that is used in these service procedures. In addition, some states or municipalities may have additional requirements that must also be adhered to for responsible management of refrigerants. Know the applicable laws and follow them.

### ⚠ WARNING

#### Proper Field Wiring and Grounding Required!

Failure to follow code could result in death or serious injury. All field wiring **MUST** be performed by qualified personnel. Improperly installed and grounded field wiring poses **FIRE** and **ELECTROCUTION** hazards. To avoid these hazards, you **MUST** follow requirements for field wiring installation and grounding as described in **NEC** and your local/state electrical codes.

### ⚠ WARNING

#### Personal Protective Equipment (PPE) Required!

Failure to wear proper PPE for the job being undertaken could result in death or serious injury. Technicians, in order to protect themselves from potential electrical, mechanical, and chemical hazards, **MUST** follow precautions in this manual and on the tags, stickers, and labels, as well as the instructions below:

- Before installing/servicing this unit, technicians **MUST** put on all PPE required for the work being undertaken (Examples; cut resistant gloves/sleeves, butyl gloves, safety glasses, hard hat/bump cap, fall protection, electrical PPE and arc flash clothing). **ALWAYS** refer to appropriate Safety Data Sheets (SDS) and OSHA guidelines for proper PPE.
- When working with or around hazardous chemicals, **ALWAYS** refer to the appropriate SDS and OSHA/GHS (Global Harmonized System of Classification and Labeling of Chemicals) guidelines for information on allowable personal exposure levels, proper respiratory protection and handling instructions.
- If there is a risk of energized electrical contact, arc, or flash, technicians **MUST** put on all PPE in accordance with OSHA, NFPA 70E, or other country-specific requirements for arc flash protection, **PRIOR** to servicing the unit. **NEVER PERFORM ANY SWITCHING, DISCONNECTING, OR VOLTAGE TESTING WITHOUT PROPER ELECTRICAL PPE AND ARC FLASH CLOTHING. ENSURE ELECTRICAL METERS AND EQUIPMENT ARE PROPERLY RATED FOR INTENDED VOLTAGE.**

**⚠ WARNING****Follow EHS Policies!**

Failure to follow instructions below could result in death or serious injury.

- All Trane personnel must follow the company's Environmental, Health and Safety (EHS) policies when performing work such as hot work, electrical, fall protection, lockout/tagout, refrigerant handling, etc. Where local regulations are more stringent than these policies, those regulations supersede these policies.
- Non-Trane personnel should always follow local regulations.

## Copyright

This document and the information in it are the property of Trane, and may not be used or reproduced in whole or in part without written permission. Trane reserves the right to revise this publication at any time, and to make changes to its content without obligation to notify any person of such revision or change.

## Trademarks

All trademarks referenced in this document are the trademarks of their respective owners.

## Revision History

- Updated Kit Contents chapter.
- Updated Installation chapter.
- Updated Combustion Air section in Category III Installation chapter.
- Running edits.



# Kit Contents

The location of the vent terminal must be in accordance with the National Fuel Gas Code ANSI Z223.1 (NFPA 54) in the U.S. or the Natural Gas Installation Code CSA-B149.1 or the Propane Gas Installation Code CSA-B149.2 in Canada. Minimum clearances are shown in [Table 1, p. 6](#) and [Figure 4, p. 7](#), [Figure 5, p. 8](#), and [Figure 6, p. 9](#).

This combustion Air Inlet Kit utilizes one 4-in. termination in which both the discharge flue gas and the combustion air inlet pass.

### KIT CONTENTS (Figure 1, p. 4)

1. Part No. 11J37R08571-001: (1) Flue Vent Terminal
2. Part No. 11507R06601-DBL: (1) Combustion Air Inlet Box Assembly (see [Figure 2, p. 4](#) for dimensional data)
3. Part No. 11257R06665-DBL: (1) Air Inlet Screen
4. Part No. 11507R06693-DBL: (1) Deflector Disk \*

\* Deflector disk comes with brackets (11252-06692) and screws for installation.

### Also Included:

- Part No. J30-09406: *Installation Instructions: Four-Inch Combustion Air Inlet Kit - Tubular Gas-Fired Direct Spark Propeller Unit Heaters - Category III Venting for Separated Combustion for 30,000 to 75,000 Btu/h*
- (1) Part No. 11H03R03612-002: Tube of High Temp Silicone Sealant
- (3) Part No. 11H03R09471-004: Gasket, O-ring (4 in.)

**Figure 1. Kit contents (drawing CAT-10429\_A)**

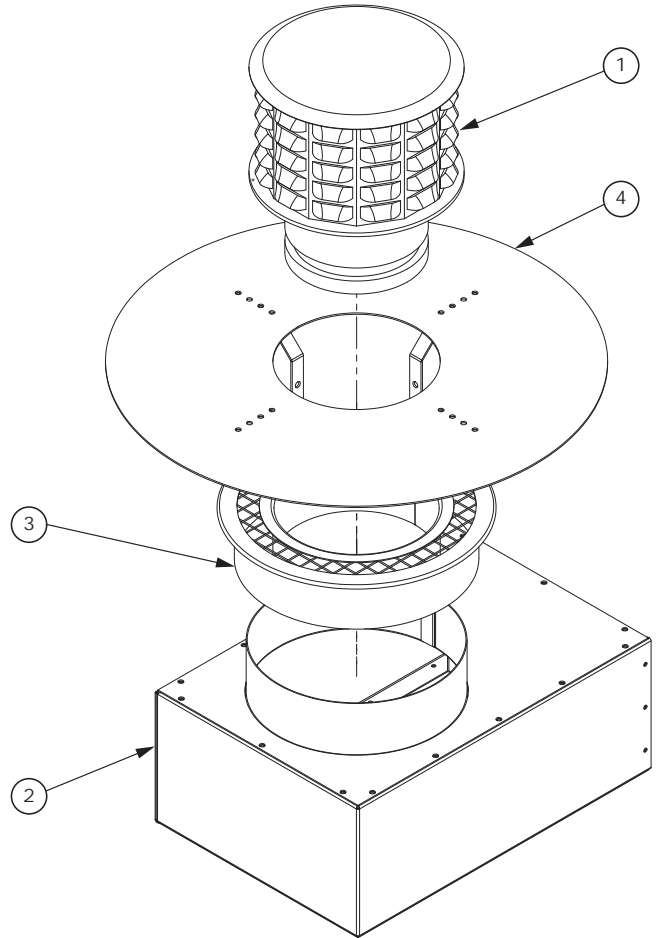

**Figure 2. Combustion air inlet box dimensions (drawing D6875C)**

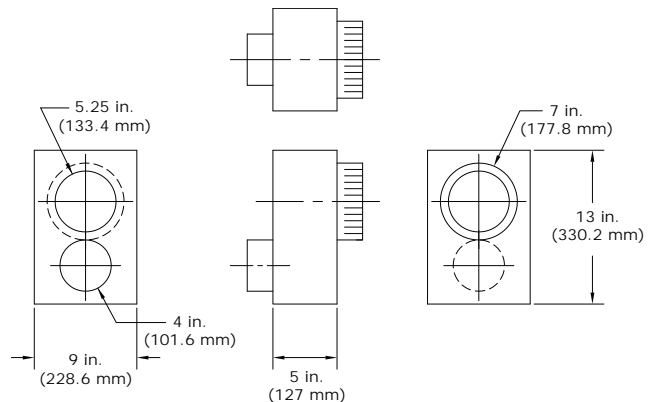



# Venting

All unit heaters must be vented! All Venting installations shall be in accordance with the latest edition of Part 7, Venting of Equipment of the National Fuel Gas Code, ANSI Z223.1 (NFPA 54), or applicable provisions of local building codes. All venting of residential tubular unit heaters must comply with CSA International Requirements 10.96 U.S. for Unit Heaters for Residential Use (2<sup>nd</sup> Edition). For Canadian installations, refer to [“Additional Requirements for Canadian Installations,”](#) p. 5.

## ⚠ WARNING

### Carbon Monoxide Poisoning!

**Your venting system must not be blocked by any snow, snow drifts, or any foreign matter. Inspect your venting system to ensure adequate ventilation exists at all time! Failure to follow these instructions could result in Carbon Monoxide Poisoning (symptoms include grogginess, lethargy, inappropriate tiredness, or flu-like symptoms) which could result in death or serious injury.**

When an existing heater is removed or replaced in venting system, the venting system may not be properly sized to vent the attached appliances. An improperly sized vent system can cause formulation of condensate or leakage or spillage of flue gases.

The following steps shall be followed with each appliance connected to the venting system placed in operation, while any other appliances connected to the venting system are not in operation:

1. Seal any unused openings in the venting system;
2. Inspect the venting system for proper size and horizontal pitch, as required in the National Fuel Gas Code, ANSI Z223.1 (NFPA 54) and these instructions. Determine that there is no blockage or restriction, leakage, corrosion and other deficiencies, which could cause an unsafe condition.
3. In so far as practical, close all building doors and windows and all doors between the space in which the appliance(s) connected to the venting system are located and other spaces of the building. Turn on clothes dryers and any exhaust fans, such as range hoods and bathroom exhausts, so they shall operate at maximum speed. Do not operate a summer exhaust fan. Close fireplace damper.
4. Follow the lighting instructions. Place the appliance being inspected in operation. Adjust thermostat so that the appliance will operate continuously.
5. After it has been determined that each appliance connected to the venting system properly vents when tested as outlined above, return doors, windows, exhaust fans, fireplace dampers, and any other gas-burning appliance to their previous condition of use.
6. If improper venting is observed during any of the above tests, the venting system must be corrected

immediately so that the system conforms with the National Fuel Gas Code, ANSI Z223.1 (NFPA 54) . When resizing any portion of the venting system, the venting system should be resized to approach the minimum size as determined using the appropriate tables in Appendix G of the National Fuel Gas Code, ANSI Z223.1 (NFPA 54).

The unit heater shall be connected to a factory built chimney or vent complying with a recognized standard, or a masonry or concrete chimney lined with a lining material acceptable to the authority having jurisdiction. Venting into an unlined masonry chimney is prohibited.

## Additional Requirements for Canadian Installations

The following instructions apply to Canadian installations in addition to installation and operating instructions.

1. Installation must conform with local building codes, or in the absence of local codes, with current CSA-B149.1, Installation Codes for Natural Gas Burning Appliances and Equipment, or CSA-B149.2, Installation Codes for Propane Gas Burning Appliances and Equipment.
2. Any reference to U.S. standards or codes in these instructions are to be ignored and the applicable Canadian standards or codes applied.



# Installation

## General Guidelines

The following guidelines apply to all categories to follow.

**Table 1. Vent systems—termination clearance requirements**

Structure/ Object	Minimum Clearances for Termination Locations	
	USA	Canada
Door, window, or gravity vent inlet; combustion air inlet for other appliances	9 in. (230 mm) for 10,000 to 50,000 Btu/h input; 12 in. for input exceeding 50,000 Btu/h	9 in. (230 mm) for 10,000 to 50,000 Btu/h input; 12 in. (305 mm) for input exceeding 50,000 Btu/h
Forced air inlet within 10 ft (3.04 m)	3 ft above	6 ft (1.8 m)
Adjoining building or parapet	10 ft (3.04 m)	10 ft (3.04 m)
Adjacent public walkways	7 ft (2.1 m) above grade	7 ft (2.1 m) above grade
Electric, gas meters, and regulators	4 ft horizontal	3 ft (0.9 m) horizontally from meter/regulator assembly 6 ft (1.8 m), any direction, from a gas service regulator vent outlet
Above grade level <sup>(a)</sup>	1 ft (0.3 m)	1 ft (0.3 m)

(a) Minimum above snow depth, or per local code, whichever is greater.

Do not damper or add heat recovery devices to the flue piping. Failure to open such a damper prior to operating the gas unit heater will result in the spillage of flue gas into the occupied space.

Avoid installing units in areas under negative pressure. When required, a flue vent fan should be installed in accordance with the instructions included with the fan.

Vent connectors serving Category I and Category II heaters shall not be connected into any portion of mechanical draft systems operating under positive vent pressure.

Maintain 1 in. (25.4 mm) clearance between the vent pipe and combustible materials.

ANSI now organizes vented appliances into four categories.

**Table 2. Venting categories**

	Non-condensing	Condensing
Negative Vent Pressure	I	II
Positive Vent Pressure	III	IV

### Category I

Includes non-condensing appliances with negative vent pressure, like the traditional atmospheric unit heater.

### Category II

Groups condensing appliances with negative vent pressure.

### Category III

Appliances are non-condensing and operate with a positive vent pressure.

### Category IV

Covers condensing appliances with positive vent pressure.

**Note:** Category II and IV do not apply to equipment specified within this manual.

## Access Panel Seal

Cut gasket (provided with unit) to lengths listed in [Table 3, p. 7](#). Remove paper backing and adhere to access panel making certain that the entire perimeter is covered ([Figure 3, p. 7](#)).

## Power Supply Inlet

After powerline is run to main control board, seal gap between cord and hole in rear panel with silicone sealant.

## Horizontal Termination

### ⚠ WARNING

#### Proper Vent Pipe Required!

**Never use a pipe of a diameter other than specified! Never use PVC, ABS, or any other non-metallic pipe for venting! Failure to follow instructions could result in death, serious injury, and property damage.**

**Note:** When using double-wall vent pipe, O-ring gaskets are NOT required and should be discarded. When using single-wall vent pipe, one O-ring should be inserted in each of the flue pipe openings in the air inlet screen, deflector disk, and the top of the combustion air inlet box assembly.

Select a location on outside wall for vent terminal. In most applications, the terminal should be on level with the flue outlet of the unit, less a 0.25 in./ft (21 mm/m) pitch for condensate drainage toward the outside of the building. See [Table 1, p. 6](#), [Figure 4, p. 7](#), and [Figure 5, p. 8](#).

Cut hole through wall for 7 in. (178 mm) combustion air pipe. Install thimble if required by local codes or type of wall construction.

Combustion air inlet box may be fastened directly to wall or spaced away from wall using suitable brackets (field supplied). Cut length of 7 in. (178 mm) pipe so that it will protrude 4 in. (102 mm) through the wall when the box is mounted in position. Fasten pipe to box with sheet metal

screws, using at least three screws per joint. Seal joint with high temperature silicone sealant.

Insert pipe through wall and fasten adaptor box in place so that the pipe pitches downward 0.25 in./ft (21 mm/m) toward the outside. Flash and/or caulk 7 in. (178 mm) pipe on outside wall. Install inlet air screen assembly and fasten to 7 in. (178 mm) pipe with screws. Insert a continuous length of 4 in. UL 1738 listed vent pipe through the 5.25 in. opening. Position the pipe to extend a minimum of 12 in. (305 mm) beyond the inlet air screen.

Seal the space between the vent pipe and 5.25 in. opening of the combustion air inlet box using high temperature silicone sealant. Install deflector disk on UL 1738 listed vent pipe 2.5 in. (63.5 mm) from inlet air screen and fasten with screws. Install vent terminal on end of UL 1738 listed vent pipe, fasten with screws and seal joint (see [Figure 5, p. 8](#)).

Connect flue pipe and combustion air pipe from combustion air inlet box to unit according to ["Category III Installation," p. 10](#). Joint between UL 1738 listed vent pipe and single wall vent pipe must be sealed with high temperature silicone sealant.

UL 1738 flue pipe should be installed so the arrows indicating direction of airflow on the vent pipe point away from the unit.

**Figure 4. Horizontal vent termination location (drawing D9266)**

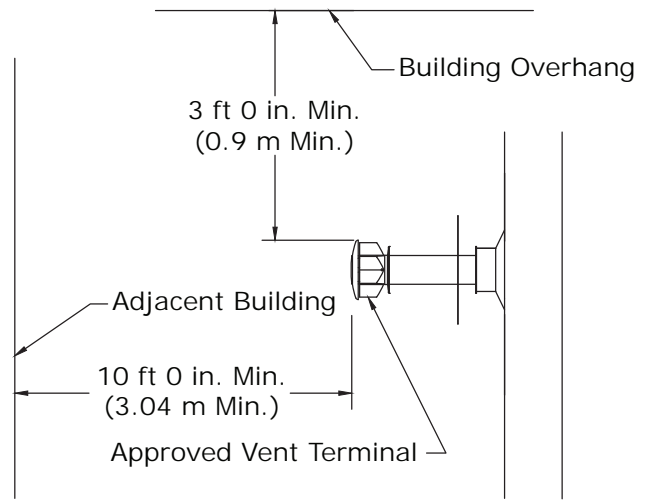

**Figure 3. Access panel seal (drawing D-8615)**

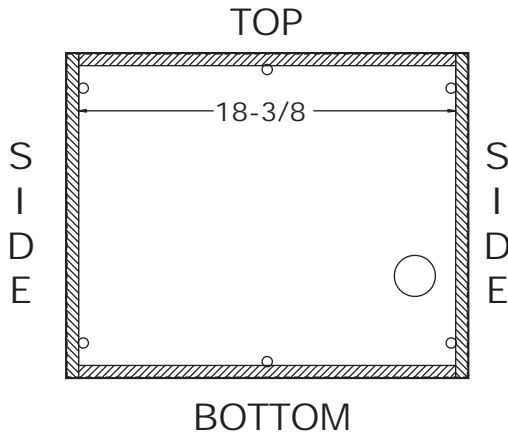

**Note:** For side dimensions, see [Table 3, p. 7](#).

**Table 3. Gasket lengths**

Unit size	Top/bottom gasket length (in.)	Qty	Right/left gasket length (in.)	Qty
030	18-3/8	2	12-3/8	2
045	18-3/8	2	12-3/8	2
060	18-3/8	2	15-7/8	2
075	18-3/8	2	15-7/8	2



**Figure 5. Horizontal vent termination (drawing CAT-10428\_A)**

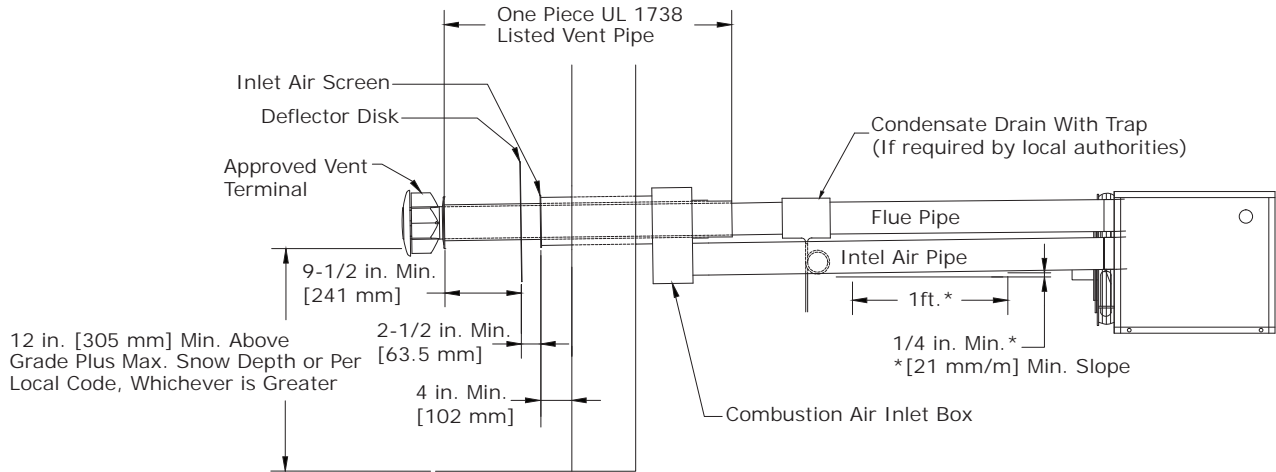

## Vertical Termination

### ⚠ WARNING

#### Proper Vent Pipe Required!

**Never use a pipe of a diameter other than specified! Never use PVC, ABS, or any other non-metallic pipe for venting! Failure to follow instructions could result in death, serious injury, and property damage.**

**Note:** When using double-wall vent pipe, O-ring gaskets are NOT required and should be discarded. When using single-wall vent pipe, one O-ring should be inserted in each of the flue pipe openings in the air inlet screen, deflector disk, and the top of the combustion air inlet box assembly.

Select location on roof for vent terminal, ensuring adequate space inside the building/structure for combustion air inlet box. Terminal must be at least 10 ft (3.04 m) from any wall or adjacent building or parapet (see Table 1, p. 6).

Cut a hole through the roof for a 7 in. (178 mm) combustion air pipe. Combustion air inlet box is to be suspended from the underside of the roof using suitable brackets (field supplied). Before mounting box, cut a length of 7 in. (178 mm) pipe so that dimension A (see Figure 6, p. 9) is equal to the dimension from the top of the box to the roof surface plus 2 ft (0.61 m) or plus expected snow depth, whichever is greater. Fasten 7 in. (178 mm) pipe to combustion air inlet connection of combustion air inlet box and seal joint. Insert pipe through roof and fasten vent box in place. Flash and/or caulk 7 in. (178 mm) pipe to roof. Install inlet air screen assembly and fasten to 7 in. (178 mm) pipe with screws. Insert a 5 ft (1.5 m) length of UL 1738 listed vent pipe through the 5.25 in. opening with the "UP" arrow pointing up. Position the pipe to extend 12 in. (305 mm) beyond the inlet air screen.

Seal the space between the vent pipe and opening of combustion air inlet box using high temperature silicone sealant. Install deflector disk on UL 1738 listed vent pipe 2.5 in. above inlet air screen and fasten with screws. Seal joint between deflector disk and pipe with silicone sealant. Install vent terminal on top of UL 1738 listed vent pipe, fasten with screws and seal joint (see Figure 6, p. 9).

Connect flue pipe and combustion air pipe from combustion air inlet box to unit according to "Category III Installation," p. 10. Joint between UL 1738 listed vent pipe and single wall vent pipe must be sealed with high temperature silicone sealant.

UL 1738 flue pipe should be installed so the arrows indicating direction of airflow on the vent pipe point away from the unit.



**Figure 6. Vertical vent termination (drawing D9264B)**

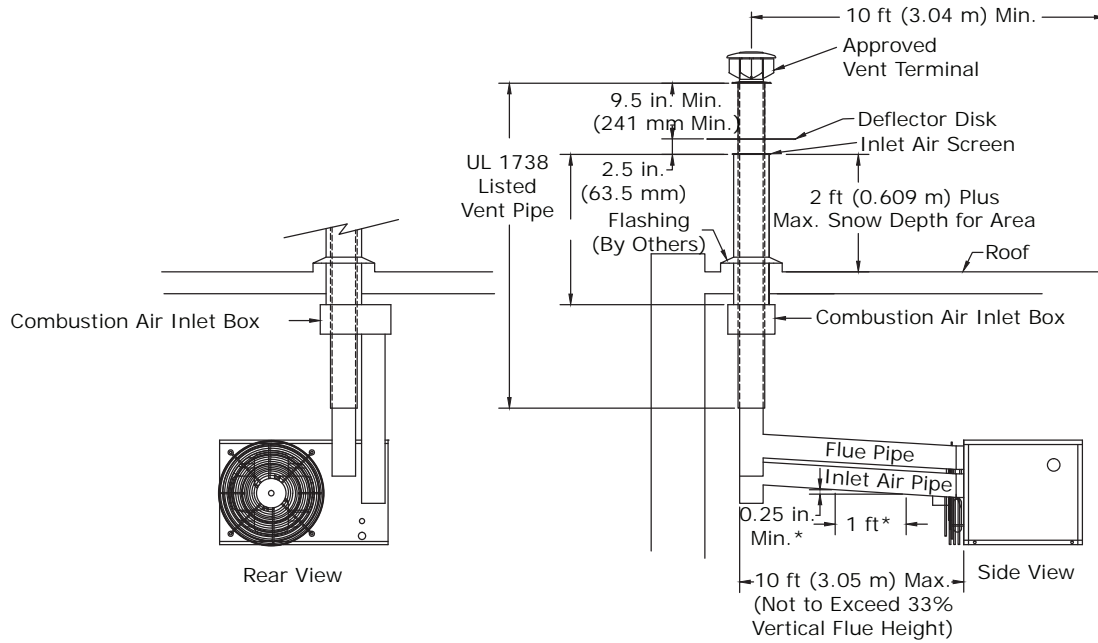



# Category III Installation

## Combustion Air

### ⚠ WARNING

#### Carbon Monoxide!

Never operate unit heaters without combustion air and flue gas piping in place. Each unit **MUST** have an individual vent pipe! Each unit **MUST NOT** be connected to other vent systems or to a chimney. Your venting system must not be blocked by any snow, snow drifts, or any foreign matter. Inspect your venting system to ensure adequate ventilation exists at all times! Failure to follow these instructions could result in Carbon Monoxide Poisoning (symptoms include grogginess, lethargy, inappropriate tiredness, or flu-like symptoms) which could result in death or serious injury.

1. The combustion air system installation must be in accordance with the current edition of the National Fuel Gas Code-NFPA 54 or ANSI Z223.1 National Fuel Gas Code. In Canada, installation must be in accordance with CSA-B149.1 "Installation Code for Natural Gas Burning Appliances and Equipment" and CSA-B149.2 "Installation Code for Propane Burning Appliances and Equipment".
2. The combustion air inlet box, inlet air screen, deflector disk, and vent terminal provided with the unit heater must be installed at the termination point of the combustion air/vent system. See [Figure 1, p. 4](#), [Figure 2, p. 4](#), [Figure 4, p. 7](#), [Figure 5, p. 8](#), and [Figure 6, p. 9](#).
3. Each unit heater **MUST** have its own combustion air system. It **MUST NOT** be connected to other air intake systems.
4. Combustion air intake duct may be PVC, CPVC, Type B vent, single-wall, double-wall or other material approved by local code authority. Never use duct size other than diameter stated in these instructions.
5. Long runs of single- or double-wall combustion air piping passing through an unheated space may require insulating if condensation becomes noticeable.
6. The combustion air system must be installed to prevent collection of condensate. Pitch horizontal pipes downward 0.25 in./ft (21 mm/m) toward the inlet cap to facilitate drainage. Vertical combustion air pipes should be piped as depicted in [Figure 6, p. 9](#).
7. The equivalent length of the combustion air system must not be less than 5 feet (1.5 m) and must not exceed 30 feet (9 m). Equivalent length equals the total length of straight pipe plus 5 feet (1.5 m) for each 90° elbow and 2.5 feet (0.76 m) for each 45° elbow.

**Note:** For optimum performance keep the combustion air system as straight as possible.

8. Each slip joint must be secured with at least three corrosion resistant screws. Two full turns of 3M™ #425 Aluminum Foil Tape or its equivalent must then be used to seal each joint. General Electric RTV-108, Dow-Corning® RTV-732 or an equivalent silicone sealant with a temperature rating of 500°F may be used instead of the tape.
9. For horizontal combustion air systems longer than 5 ft (1.5 m), the system must be supported from overhead building structures at 4 foot (1.2 m) intervals in the U.S. and at 3 foot (0.91 m) intervals in Canada.

## Exhaust Venting

### ⚠ WARNING

#### Carbon Monoxide!

Never operate unit heaters without combustion air and flue gas piping in place. Each unit **MUST** have an individual vent pipe! Each unit **MUST NOT** be connected to other vent systems or to a chimney. Your venting system must not be blocked by any snow, snow drifts, or any foreign matter. Inspect your venting system to ensure adequate ventilation exists at all times! Failure to follow these instructions could result in Carbon Monoxide Poisoning (symptoms include grogginess, lethargy, inappropriate tiredness, or flu-like symptoms) which could result in death or serious injury.

### ⚠ WARNING

#### Proper Vent Pipe Required!

Never use a pipe of a diameter other than specified! Never use PVC, ABS, or any other non-metallic pipe for venting! Failure to follow instructions could result in death, serious injury, and property damage.

**Note:** It may be necessary to increase the clearance distances if there is a possibility of distortion or discoloration of adjacent materials.

1. Vent system installation must be in accordance with the current National Fuel Gas Code-NFPA 54 or ANSI Z223.1 National Fuel Gas Code. In Canada installation must be in accordance with CSA-B149.1 "Installation Code for Natural Gas Burning Appliances and Equipment" and CSA-B149.2 "Installation Code for Propane Burning Appliances and Equipment".
2. A factory supplied Combustion Air Inlet Kit (which includes a combustion air inlet box, air inlet screen, deflector disk and vent terminal) **MUST** be installed at the termination point of the combustion air/vent system. See [Figure 1, p. 4](#), [Figure 2, p. 4](#), [Figure 4, p. 7](#), [Figure 5, p. 8](#), and [Figure 6, p. 9](#).

3. Each unit heater **MUST** have its own vent system. It **MUST NOT** be connected to other vent systems or to a chimney.
4. Use UL 1738 listed single- or double-wall pipe for the vent system. For installations in Canada, use corrosion resistant and gas-tight, listed vent pipe conforming with local building codes, or in the absence of local building codes, with current CSA-B149.1, "Installation Codes for Natural Gas Burning Appliances and Equipment" or CSA-B149.2, "Installation Codes for Propane Gas Burning Appliances and Equipment". For residential installations in the United States, vent pipe approved for Category III appliances must be used between the appliance and the combustion air inlet box.
5. Any run of single- or double-wall vent pipe passing through an unheated space must be insulated with an insulation suitable to 550° F.
6. The vent system must be installed to prevent collection of condensate. Pitch horizontal pipes downward 0.25 in./ft (21 mm/m) toward the vent cap to facilitate drainage. Vertical vent pipes should be piped as depicted in [Figure 6, p. 9](#).
7. The equivalent length of the vent system must not be less than 5 ft (1.5 m) and must not exceed 30 ft (9 m). The equivalent length equals the total length of straight pipe plus 5 ft (1.5 m) for each 90° elbow and 2.5 ft (0.76 m) for each 45° elbow.
8. For horizontal vent systems longer than 5 ft (1.5 m), the system must be supported from overhead building structures at 4 ft (1.2 m) intervals in the U.S. and at 3 ft (0.91 m) intervals in Canada.
9. The exhaust vent system must remain at a minimum distance of 1 in. (25 mm) from all combustible materials. Any part of the vent system that passes through a combustible material must be properly insulated.

Trane - by Trane Technologies (NYSE: TT), a global climate innovator - creates comfortable, energy efficient indoor environments for commercial and residential applications. For more information, please visit [trane.com](http://trane.com) or [tranetechnologies.com](http://tranetechnologies.com).

Trane has a policy of continuous product and product data improvement and reserves the right to change design and specifications without notice. We are committed to using environmentally conscious print practices.

GTNE-SVN002C-EN 21 Aug 2020  
Supersedes GTNE-SVN002B-EN (Jul 2015)