



Installation Instructions

Trane Rental Services

Low Temp Air Handling Unit



⚠ SAFETY WARNING

Only qualified personnel should install and service the equipment. The installation, starting up, and servicing of heating, ventilating, and air-conditioning equipment can be hazardous and requires specific knowledge and training. Improperly installed, adjusted or altered equipment by an unqualified person could result in death or serious injury. When working on the equipment, observe all precautions in the literature and on the tags, stickers, and labels that are attached to the equipment.



Introduction

Read this manual thoroughly before operating or servicing this unit.

Warnings, Cautions, and Notices

Safety advisories appear throughout this manual as required. Your personal safety and the proper operation of this machine depend upon the strict observance of these precautions.

The three types of advisories are defined as follows:

- WARNING** Indicates a potentially hazardous situation which, if not avoided, could result in death or serious injury.
- CAUTION** Indicates a potentially hazardous situation which, if not avoided, could result in minor or moderate injury. It could also be used to alert against unsafe practices.
- NOTICE** Indicates a situation that could result in equipment or property-damage only accidents.

Important Environmental Concerns

Scientific research has shown that certain man-made chemicals can affect the earth's naturally occurring stratospheric ozone layer when released to the atmosphere. In particular, several of the identified chemicals that may affect the ozone layer are refrigerants that contain Chlorine, Fluorine and Carbon (CFCs) and those containing Hydrogen, Chlorine, Fluorine and Carbon (HCFCs). Not all refrigerants containing these compounds have the same potential impact to the environment. Trane advocates the responsible handling of all refrigerants.

Important Responsible Refrigerant Practices

Trane believes that responsible refrigerant practices are important to the environment, our customers, and the air conditioning industry. All technicians who handle refrigerants must be certified according to local rules. For the USA, the Federal Clean Air Act (Section 608) sets forth the requirements for handling, reclaiming, recovering and recycling of certain refrigerants and the equipment that is used in these service procedures. In addition, some states or municipalities may have additional requirements that must also be adhered to for responsible management of refrigerants. Know the applicable laws and follow them.

WARNING

Proper Field Wiring and Grounding Required!

Failure to follow code could result in death or serious injury. All field wiring **MUST** be performed by qualified personnel. Improperly installed and grounded field wiring poses **FIRE** and **ELECTROCUTION** hazards. To avoid these hazards, you **MUST** follow requirements for field wiring installation and grounding as described in NEC and your local/state/national electrical codes.

WARNING

Personal Protective Equipment (PPE) Required!

Failure to wear proper PPE for the job being undertaken could result in death or serious injury. Technicians, in order to protect themselves from potential electrical, mechanical, and chemical hazards, **MUST** follow precautions in this manual and on the tags, stickers, and labels, as well as the instructions below:

- Before installing/servicing this unit, technicians **MUST** put on all PPE required for the work being undertaken (Examples; cut resistant gloves/sleeves, butyl gloves, safety glasses, hard hat/bump cap, fall protection, electrical PPE and arc flash clothing). **ALWAYS** refer to appropriate Safety Data Sheets (SDS) and OSHA guidelines for proper PPE.
- When working with or around hazardous chemicals, **ALWAYS** refer to the appropriate SDS and OSHA/GHS (Global Harmonized System of Classification and Labeling of Chemicals) guidelines for information on allowable personal exposure levels, proper respiratory protection and handling instructions.
- If there is a risk of energized electrical contact, arc, or flash, technicians **MUST** put on all PPE in accordance with OSHA, NFPA 70E, or other country-specific requirements for arc flash protection, **PRIOR** to servicing the unit. **NEVER PERFORM ANY SWITCHING, DISCONNECTING, OR VOLTAGE TESTING WITHOUT PROPER ELECTRICAL PPE AND ARC FLASH CLOTHING. ENSURE ELECTRICAL METERS AND EQUIPMENT ARE PROPERLY RATED FOR INTENDED VOLTAGE.**

⚠ WARNING**Follow EHS Policies!**

Failure to follow instructions below could result in death or serious injury.

- All Trane personnel must follow the company's Environmental, Health and Safety (EHS) policies when performing work such as hot work, electrical, fall protection, lockout/tagout, refrigerant handling, etc. Where local regulations are more stringent than these policies, those regulations supersede these policies.
- Non-Trane personnel should always follow local regulations.

⚠ WARNING**Hazardous Service Procedures!**

Failure to follow all precautions in this manual and on the tags, stickers, and labels could result in death or serious injury.

Technicians, in order to protect themselves from potential electrical, mechanical, and chemical hazards, **MUST** follow precautions in this manual and on the tags, stickers, and labels, as well as the following instructions: Unless specified otherwise, disconnect all electrical power including remote disconnect and discharge all energy storing devices such as capacitors before servicing. Follow proper lockout/tagout procedures to ensure the power can not be inadvertently energized. When necessary to work with live electrical components, have a qualified licensed electrician or other individual who has been trained in handling live electrical components perform these tasks.

⚠ WARNING**Hazardous Voltage!**

Failure to disconnect power before servicing could result in death or serious injury.

Disconnect all electric power, including remote disconnects before servicing. Follow proper lockout/tagout procedures to ensure the power can not be inadvertently energized. Verify that no power is present with a voltmeter.

⚠ WARNING**Live Electrical Components!**

Failure to follow all electrical safety precautions when exposed to live electrical components could result in death or serious injury.

When it is necessary to work with live electrical components, have a qualified licensed electrician or other individual who has been properly trained in handling live electrical components perform these tasks.

⚠ WARNING**Improper Unit Lift!**

Failure to properly lift unit in a LEVEL position could result in unit dropping and possibly crushing operator/ technician which could result in death or serious injury, and equipment or property-only damage.

Test lift unit approximately 24 inches (61 cm) to verify proper center of gravity lift point. To avoid dropping of unit, reposition lifting point if unit is not level.

⚠ WARNING**Rotating Components!**

Failure to disconnect power before servicing could result in rotating components cutting and slashing technician which could result in death or serious injury.

During installation, testing, servicing and troubleshooting of this product it may be necessary to work with live and exposed rotating components. Have a qualified or licensed service individual who has been properly trained in handling exposed rotating components, perform these tasks.

⚠ WARNING**Rotating Components!**

Failure to disconnect power before servicing could result in rotating components cutting and slashing technician which could result in death or serious injury.

Disconnect all electric power, including remote disconnects before servicing. Follow proper lockout/tagout procedures to ensure the power can not be inadvertently energized.

Copyright

This document and the information in it are the property of Trane, and may not be used or reproduced in whole or in part without written permission. Trane reserves the right to revise this publication at any time, and to make changes to its content without obligation to notify any person of such revision or change.

Trademarks

All trademarks referenced in this document are the trademarks of their respective owners.

Revision History

- Added the Dimensions and Weights chapter.
- Updated the F0 units in the Three-Way Valve Operation chapter.
- Updated the Thermostat sequence of operation schematic figure in the Thermostat chapter.



Table of Contents

- Introduction 5
- Model Number Description 6
- Applications Considerations 7
 - Waterside 7
 - Airside 7
 - Water Treatment 7
 - Multiple AHU Applications 7
- General Information 8
 - Airside Data 8
 - Electrical Data 8
 - Waterside Data 8
 - Features 9
 - F0 9
 - F1 9
- Dimensions and Weights 10
- Modes of Operation 13
 - (F1) Units 15
 - Three Main Operational Modes 15
- Installation and Start-Up Guidelines 17
- Three-Way Valve Operation 18
 - (F0) Units 18
 - Manually Adjust Electric Actuators 18
 - (F1) Units - Bypass Valve Positions 18
- Thermostat 19
 - (F0) Units 19
 - (F1) Units 21
- Defrost Control Instructions 22
 - (F0) Units 22
 - Dial Description 22
 - To Set Timer 22
 - (F1) Units 22



Introduction

This installation manual is exclusively for rental units from Trane Rental Services temporary cooling solutions.

This document includes:

- Mechanical, electrical requirements, and a detailed description for modes of operation.
- Start-up, equipment installation, troubleshooting guidelines, and maintenance.

Contact Trane Rental Services (TRS) for availability of equipment prior to ordering rental equipment. Equipment is available on a first come, first-serve basis, but can be reserved with a signed rental agreement.



Model Number Description

Digit 1, 2 — Unit Model

RS = Rental Services

Digit 3, 4 — Unit Type

AL = Air Handling Unit (Low temp)

Digit 5, 6, 7, 8 — Nominal Tonnage

0030 = 30 Tons

Digit 9 — Voltage

F = 460/60/3

Digit 10 — Design Sequence

0 to 9

Digit 11, 12 — Incremental Designator

AA = Incremental Designator



Applications Considerations

Waterside

- The low temp air handling units should only be used for applications that are well insulated.
- Low temp air handling units are specifically designed for cooler, freezer type applications where there is a requirement for air temperatures below 32°F. In these applications, the use of glycol is highly recommended.
- This equipment is designed to be placed indoors. Special steps need to be taken to run drain lines to their proper building site drainage.

Airside

- Some version models of these air handling units (AHU) are only able to provide constant volume to the space (F0 units). Special steps need to be taken so that in applications above 32°F, the fan does not exceed a face velocity of 650 FPM to prevent moisture carryover.

Important: *Some units do not have VFD capabilities. Airflow modulation can only be achieved by restricting the airflow. Contact Trane Rental Services for suggestions on accomplishing this task. F1 model AHUs do have the capability to modulate air since they are equipped with a VFD and soft starter.*

- These unit does not have return air connections. They do have the ability to connect to a long throw adapter (F0 units) or to four, 20-inch duct connections (F1 units) to direct the supply air to the place of choosing.

Water Treatment

Dirt, scale, products of corrosion, and other foreign material will adversely affect heat transfer. It is good practice to add strainers upstream the cooling coils to efficiently help transfer heat.

Multiple AHU Applications

In order to prevent a decrease in airflow supply due to excessive frozen coils, the unit triggers a timed defrost cycle. While the cycle is on, the fan will be turned off and cooling will not be provided. In order to continuously meet building load requirements TRS recommends the use of at least one additional AHU to meet the building cooling load while other unit(s) are in a defrost cycle.



General Information

Labels	Value
Model Number	PCC-1L-3210-4-7.5
Ambient Operating Conditions	-20°F to 100°F ^(a)

(a) For ambient conditions below 40°F, glycol is recommended.

Airside Data

Labels	Value
Discharge Air Configuration	Horizontal
Flex Duct Connection Qty and Size	(1) 36-in. round ^(a) (F0) units (4) 20-in. round (F1) units
Nominal Air Flow (cfm)	12,100 ^(b)
Discharge Static Pressure @ Nominal Airflow	1.5-in. ESP
Maximum Air Flow (cfm)	24,500
Discharge Static Pressure @ Maximum Airflow	0.5-in. ESP

Note: Subject to change at any time without notice or liability.

(a) With long throw adapter.

(b) Actual airflow is dependent upon external static pressure requirement. Contact Trane Rental Services for specific airflow and static pressure information.

Electrical Data

Labels	Value
Supply Motor Size	7.5 hp/11 A
Heater Circuit	37,730 W/47.35 A
Supply Motor Speed	1160 rpm
Fused Disconnect/Circuit Breaker	Yes
Number of Electrical Circuits	1
Voltage 460V	3-phase
Frequency	60 Hz
Minimum Circuit Ampacity (MCA)	61 A
Maximum Over current Protection (MOP)	80 A

Note: For additional electrical information contact Trane Rental Services.

Waterside Data

NOTICE

Water Damage!

Connecting all drains to a common line with only one trap could result in condensate retention and possible water damage to the air handler or adjoining space. When more than one module has a drain pan, trap each module individually.

Labels	Value
Water Connection Size	2.5-in.
Water Connection Type	Grooved
Drain Pipe Size	2.0-in. (F0 Units) 3/4-in. (F1 Units)
Drain Pipe Connection Type	Internal Pipe Thread (F0 Units) Garden Hose (F1 Units)

Table 1. Coil capacity

Coil Type	Entering/Leaving Water Temp (°F)	Water Flow (gpm)	Pressure Drop (ft of H ₂ O)	Entering/Leaving Air Temp (°F)	Coil Capacity (Btuh)
Chilled Water	0/3.4	70	16.17	14/6.8	105,077
	0/3.9	90	17.39	16/9.7	158,567
	0/3.1	120	27.9	16/9.4	166,583

Notes:

- Selection based on 50 percent propylene glycol/water solution.
- Selection is required for actual AHU performance.
- Contact Trane Rental Services for specific selection information.
- Maximum waterside pressure is 150 psi (2.31' H₂O = 1 psi).

Features

F0

- Electric coil defrost with timer and three-way actuated valve for coil bypass purposes
- Drain pan electrically heated

F1

- Electric coil defrost with timer and three-way actuated valve for coil bypass purposes
- Drain pan electrically heated
- A black powder coated cage with fork pockets
- Electrical control cabinet (NEMA 3R)
- Supply plenum with four, 20-inch round duct outlets
- Rack with 12, 20x16x2-inch filters
- Daisy chain capable



Dimensions and Weights

⚠ WARNING

Improper Unit Lift!

Failure to properly lift unit in a **LEVEL** position could result in unit dropping and possibly crushing operator/ technician which could result in death or serious injury, and equipment or property-only damage.

Test lift unit approximately 24 inches (61 cm) to verify proper center of gravity lift point. To avoid dropping of unit, reposition lifting point if unit is not level.

Table 2. F0 and F1 (AA-CO)

Unit	F0	F1 (AA-CO)	F1 (CP-CY)
Length	9 ft. 6 in.	8 ft. 6 in.	8 ft. 5.5 in.
Width without Long Throw Adapter	4 ft. 4 in.	5 ft. 5 in.	8 ft. 6 in.
Width with Long Throw Adapter	6 ft. 0 in.	n/a	N/A
Height	7 ft. 2 in.	7 ft. 3 in.	7 ft. 9 in.
Shipping Weight	2,463 lb.	3,280 lb.	3,280 lb.

Note: Lifting Device: Forklift or Crane.

Figure 1. RSAL0030F0

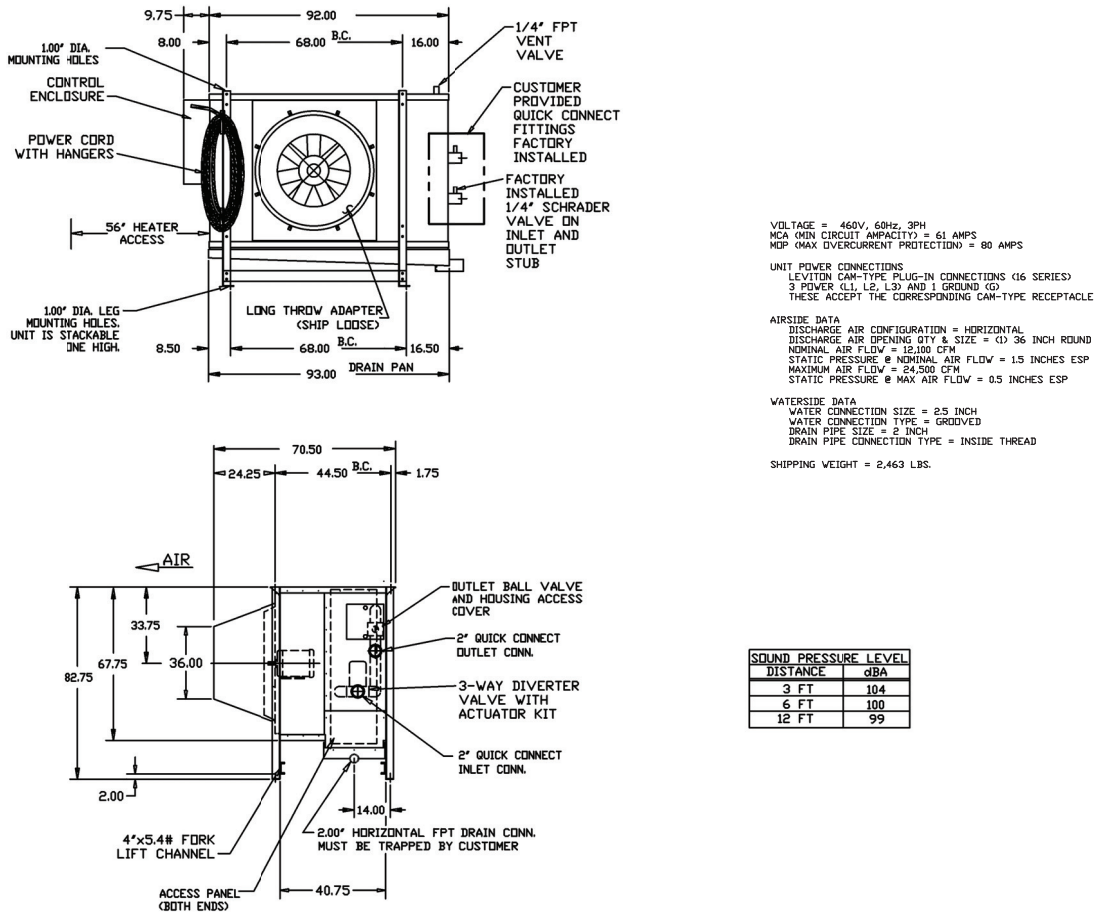
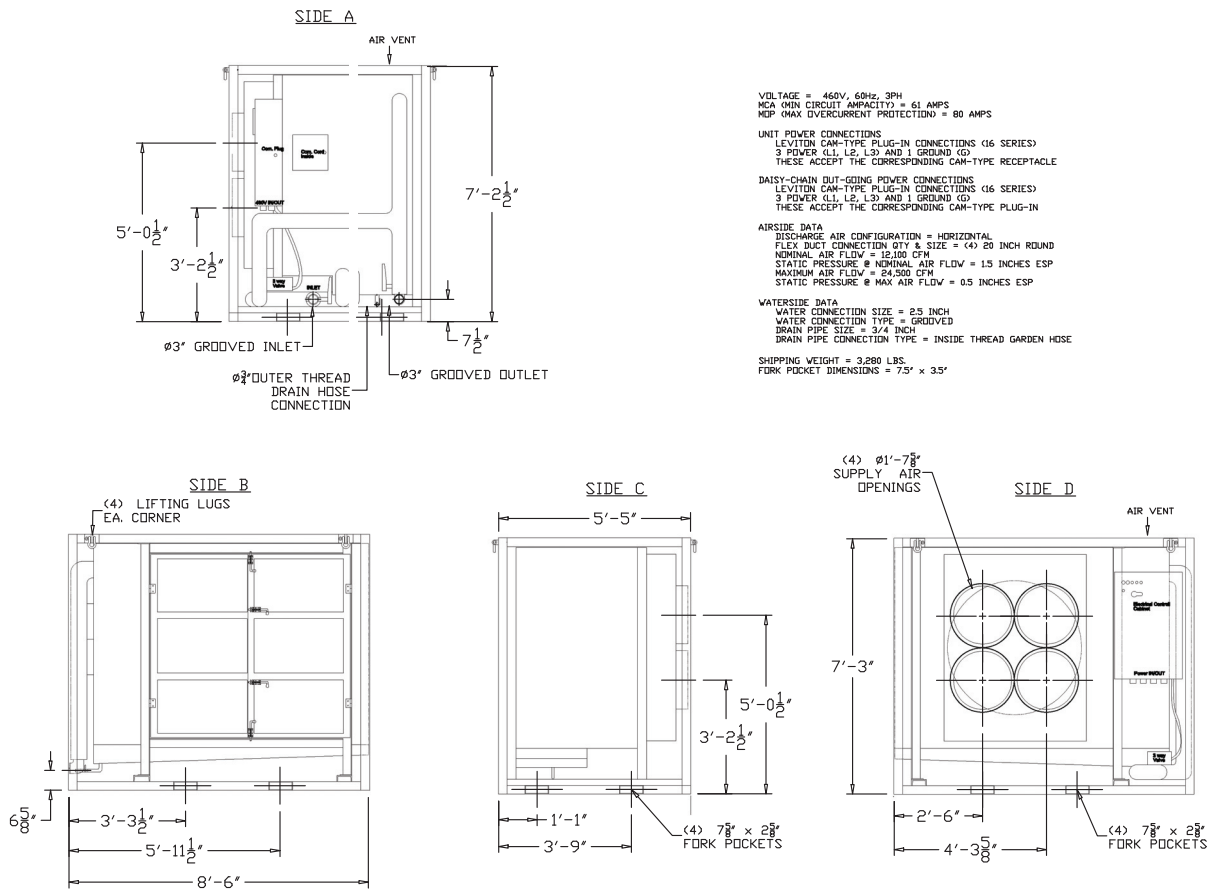

Figure 2. RSAL0030F1AA-CO





Dimensions and Weights

Figure 3. RSAL0030F1CP-F1CY

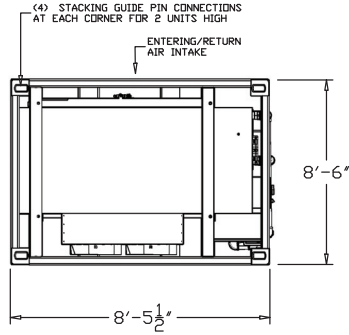

VOLTAGE = 460V, 60Hz, 3PH
 MCA (MIN CIRCUIT AMPACITY) = 61 AMPS
 MOP (MAX OVERCURRENT PROTECTION) = 80 AMPS

UNIT POWER CONNECTIONS
 LEVITON CAM-TYPE PLUG-IN CONNECTIONS (16 SERIES)
 3 POWER (L1, L2, L3) AND 1 GROUND (G)
 THESE ACCEPT THE CORRESPONDING CAM-TYPE RECEPTACLE

DAISY-CHAIN OUT-GOING POWER CONNECTIONS
 LEVITON CAM-TYPE PLUG-IN CONNECTIONS (16 SERIES)
 3 POWER (L1, L2, L3) AND 1 GROUND (G)
 THESE ACCEPT THE CORRESPONDING CAM-TYPE PLUG-IN

AIRSIDE DATA
 DISCHARGE AIR CONFIGURATION = HORIZONTAL
 FLEX DUCT CONNECTION QTY & SIZE = (4) 20 INCH ROUND
 NOMINAL AIR FLOW = 12,100 CFM
 STATIC PRESSURE @ NOMINAL AIR FLOW = 1.5 INCHES ESP
 MAXIMUM AIR FLOW = 24,500 CFM
 STATIC PRESSURE @ MAX AIR FLOW = 0.5 INCHES ESP

WATERSIDE DATA
 WATER CONNECTION SIZE = 2.5 INCH
 WATER CONNECTION TYPE = GROOVED
 DRAIN PIPE SIZE = 3/4 INCH
 DRAIN PIPE CONNECTION TYPE = INSIDE THREAD GARDEN HOSE

SHIPPING WEIGHT = 3,280 LBS.
 FORK POCKET DIMENSIONS = 7.5' x 3.5'

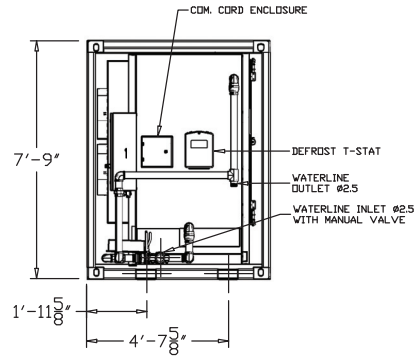
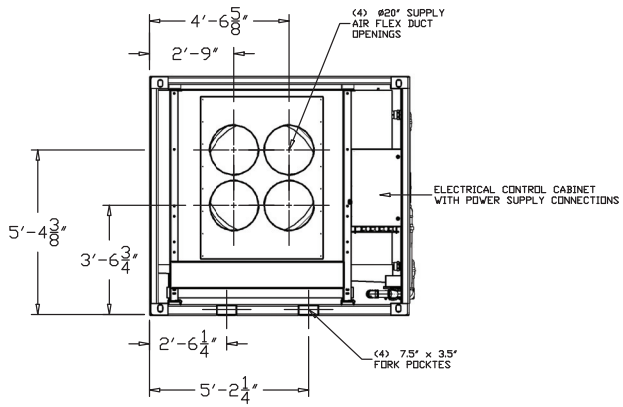

Modes of Operation

Figure 1. F0 units



⚠ CAUTION

Hazardous Voltage!

Failure to disconnect power before servicing could result in death or serious injury. Disconnect all electric power, including remote disconnects before servicing. Follow proper lockout/ tagout procedures to ensure the power can not be inadvertently energized. Verify that no power is present with a voltmeter.

⚠ CAUTION

Live Electrical Components!

Failure to follow all electrical safety precautions when exposed to live electrical components could result in death or serious injury. When it is necessary to work with live electrical components, have a qualified licensed electrician or other individual who has been properly trained in handling live electrical components perform these tasks.

Power Mode	Description
A	<ul style="list-style-type: none"> Field power leads connect to terminals L1-L2-L3 on the input side of the main circuit breaker. Close the main disconnect switch to power the unit fan motor, heater, and control circuits. When the green power light turns on, 115V power is provided to the control circuit. Open the main disconnect to remove power from the unit. The power light will turn off. The on-off switch must be on for refrigeration and defrost modes. The on-off switch will not affect the power or rotation modes. The on-off switch does not disconnect power.

⚠ WARNING

Rotating Components!

Failure to disconnect power before servicing could result in rotating components cutting and slashing technician which could result in death or serious injury. During installation, testing, servicing and troubleshooting of this product it may be necessary to work with live and exposed rotating components. Have a qualified or licensed service individual who has been properly trained in handling exposed rotating components, perform these tasks.

Modes of Operation

⚠ WARNING

Rotating Components!

Failure to disconnect power before servicing could result in rotating components cutting and slashing technician which could result in death or serious injury. Disconnect all electric power, including remote disconnects before servicing. Follow proper lockout/ tagout procedures to ensure the power can not be inadvertently energized.

Rotation Mode	Description
B	<ul style="list-style-type: none"> Field power leads L1-L2-L3 provide power to L1-L2-L3 on the phase monitor. The phase monitor checks the incoming power supply for proper phase and voltage. The unit will not operate unless all three phases are present, and in the proper phase.
	<ul style="list-style-type: none"> Close the main disconnect switch to place the unit in operating mode. Observe the rotation light. If the rotation light is on, the power supply phases are out of sequence and the fan motor will run backwards. Close the main disconnect switch and reverse any two incoming power leads (e.g. wire field lead L1 to terminal L2, and field lead L2 to terminal L1).
	<ul style="list-style-type: none"> If reversing the power leads fails to turn off the rotation light, then there is a loss of phase or voltage imbalance between legs. Reset the main circuit breaker.
	<ul style="list-style-type: none"> Check the 15 amp phase monitor fuses, and replace as necessary. If the rotation light is still on at power up, then there is a problem with the field power supply and must be corrected.
	<ul style="list-style-type: none"> If the power light is on, and the rotation light is off, the unit is powered and the fan rotation is correct.

Defrost Mode	Description
C	<p>Note: <i>The electric defrost cycle is time clock initiated and temperature terminated. Program the timer and the adjustable defrost termination fan delay thermostat settings per the need of each cooling coil.</i></p>
	<ul style="list-style-type: none"> Unit is in defrost when power and defrost lights are on.
	<ul style="list-style-type: none"> The defrost cycle will energize terminal 3 on the time clock to the heater contactor HC-1, control relay CR-1, and the actuator motor will place the three way valve in the open position.
	<ul style="list-style-type: none"> Heaters, positioned within the coil turbo spacers in the fin pack, heat up the fins to melt the accumulated frost.
	<ul style="list-style-type: none"> When the coil reaches the temperature setting of the defrost termination thermostat TDT- 1, R-Y is made triggering the time clock to terminate defrost and return to cooling mode.
	<ul style="list-style-type: none"> The defrost timer has a time-out setting to kick the coil out of defrost after a fixed time interval. A 45-minute time out is recommended as a back up to the TDT-1 termination.

Refrigeration Mode	Sequence of Operation
D	<ul style="list-style-type: none"> Unit is in cooling if power and refrigeration lights are on.
	<ul style="list-style-type: none"> Supply power from terminal 4 on the time clock to the motor contactor MS-1 and the 3-way valve actuator motor driving to the closed position.
	<ul style="list-style-type: none"> The motor contactor MS-1 circuit energizes when the circuit is made through fan delay thermostat TDT-1 R-B.
	<ul style="list-style-type: none"> The unit will continue in cooling mode until the defrost timer activates a defrost cycle.

(F1) Units



Three Main Operational Modes

Mode	Description
LEAD/FOLLOW	<ul style="list-style-type: none"> Pair with defrost cycling. The unit is designed for low temperature operation typically for below 32° applications. Set-up: switch the first unit to LEAD and set the second unit to FOLLOW. The pair should work together. Depending on the fan selection switch position on the control cabinet door fan mode is VFD or BYPASS (soft start). Important: Never adjust the defrost cycle timer longer than the cooling timer value.
LEAD	<ul style="list-style-type: none"> Standalone mode with a defrost cycle. The unit is designed to operate autonomously typically for below 32° applications. Depending on the fan selection switch position on the control cabinet door fan mode is VFD or BYPASS (soft start).
AH	<ul style="list-style-type: none"> Standalone mode without a defrost cycle. The unit is designed to operate autonomously typically for above 32° applications. Shut off the electric heating element breaker (60 amp.) located inside the control cabinet. Turn the defrost timer to the lowest time value setting. Depending on the fan selection switch position on the control cabinet door fan mode is VFD or BYPASS (soft start).

Mode	Sequence of Operation
LEAD/FOLLOW	<ul style="list-style-type: none"> Units ship with a yellow communication cable (field-installed). The cable has two, five-pin ends on a 30-foot yellow cable. Attach the cable to the receptacle on the side of the control panel. The cable is only for communication between two LTAHs for the LEAD/FOLLOW operation mode and should not be used for standalone operation. Power up - if the thermostat calls for cool, the LEAD unit runs in full cooling capacity for 50 minutes then simultaneously changes to full defrost capacity for 20 minutes. Note: Setting for full cooling and defrost capacity is adjustable from 0.05 seconds to 100 hours but factory set at 50 minutes. The thermostat sends a signal through the communication cable to the FOLLOW unit to start the cooling cycle. After the defrost cycle period is over, the LEAD unit sits idle until the FOLLOW unit initiates the defrost cycle and sends a signal back to the LEAD unit to start cooling and cycle through again. The FOLLOW unit sits idle until the LEAD unit sends a 120V signal through the communications cable initiating a cooling cycle. For 50 minutes, the FOLLOW unit runs at full cooling capacity. After the 50-minute cooling cycle, the FOLLOW unit goes into a 20 minute defrost cycle and sends a 120V signal through the communications cable back to the LEAD unit to start the cooling cycle. The FOLLOW unit will finish the defrost cycle, and sit idle until prompted to start again. Note: All timings are field adjustable. Cooling cycle - the bypass valve will energize and chilled water will flow through the unit coil. Defrost cycle and idle - the bypass valve de-energizes (spring closes) and diverts the flow of chilled water to the secondary unit via the three-inch outlet piping side of the LTAH. Defrost cycle - the coil and condensate drain pan heating elements will energize for the prescribed amount of time to thaw the unit. Note: Factory set at 20 minutes but can be adjusted. This on-off cycling continues indefinitely according to the timer settings. Cycling from one unit to another maintains the necessary cooling capacity to counteract the heat load in a space. Defrost mode will thaw ice buildup on the cooling coil.

Modes of Operation

Mode	Sequence of Operation
LEAD	<ul style="list-style-type: none"> • Power up - when the thermostat calls for cooling, the bypass valve energizes, chilled water flows through the coil, and the fan comes on. • The cooling cycle will continue until the preset time has expired and the unit then goes into defrost cycle. • Defrost cycle - the fan shuts off, the bypass valve de-energizes (spring closes) and the electric defrost heating elements energize. <p><i>Note: Factory set at 20 minutes but can be adjusted.</i></p> <ul style="list-style-type: none"> • After the defrost time has expired the LTAH goes back into the cooling cycle. • Cycling from cooling to defrost continues until the thermostat is satisfied. • To change the timing sequence, reference the TIMERS section.
AH	<ul style="list-style-type: none"> • Power up - the thermostat calls for cooling, the bypass valve energizes, and the fan comes on. • After the thermostat is satisfied, the fan shuts off, the bypass valve de-energizes and reroutes the flow of chilled water around the cooling coil. • The unit will not cycle from cooling to heating.



Installation and Start-Up Guidelines

⚠ WARNING

Hazardous Service Procedures!

Failure to follow all precautions in this manual and on the tags, stickers, and labels could result in death or serious injury.

Technicians, in order to protect themselves from potential electrical, mechanical, and chemical hazards, **MUST** follow precautions in this manual and on the tags, stickers, and labels, as well as the following instructions: Unless specified otherwise, disconnect all electrical power including remote disconnect and discharge all energy storing devices such as capacitors before servicing. Follow proper lockout/tagout procedures to ensure the power can not be inadvertently energized. When necessary to work with live electrical components, have a qualified licensed electrician or other individual who has been trained in handling live electrical components perform these tasks.

1. Check the AHU components including fan bushing set screws, motor mount bolts, electrical wire, control panel handle and signs of coil damage.

⚠ WARNING

Rotating Components!

Failure to disconnect power before servicing could result in rotating components cutting and slashing technician which could result in death or serious injury. Disconnect all electric power, including remote disconnects before servicing. Follow proper lockout/tagout procedures to ensure the power can not be inadvertently energized.

- The long throw adapter or a fan guard should be in place at all times to block accidental contact with the fan blade.
2. If the long throw adapter or fan guard needs to be replaced or installed, confirm all electrical power to the unit has been turned off before any work is performed.
 - a. To remove or replace, remove the two nuts on the lowest part of the guard or adapter.
 - b. While holding the guard or adapter with one hand, use your other hand to remove the top two nuts. Use both hands to remove the guard or adapter.
3. For systems with a defrost timer clock (F0 units), confirm the timer is set for the correct time of day and starting pins have been installed. For systems with electronic timer (F1 units), confirm the correct dials are set to the correct time.
4. It is TRS recommendation to visually inspect the three-way valve at the inlet on the coil header with a flashlight and confirm the valve is properly aligned. To do this the operator will initiate a defrost cycle and have the valve actuator open and close (F0) units.

5. When making water connections verify fittings are fitted and tightened appropriately. This is to confirm there is no leak within the system.
6. Keep closest vent to the coil open when filling with fluid to allow trapped air to escape. Close the vent valve once fluid flows out of the valve and check for water hammer in the coil.
7. After making water connections and applying power to the unit, allow the coil to frost then manually advance the defrost timer to initiate a defrost cycle.

Observe defrost cycle to see if all controls are functioning properly and the coil is clear of all frost before the system returns to cooling. A defrost cycle is only needed when the frost build up is such that it impedes the airflow through the coil.

Defrost requirements will vary in each installation and may change depending on the time of the year and other conditions. Refer to the defrost section of this document for more information on the defrost cycle.

8. In some instances (F0) units when the unit is first started, the room temperature is typically above the contact closing temperature of the fan delay thermostat (TDT-1 on wiring diagram). To energize the fans it may be necessary to install a temporary jumper wire between terminals B and N. Once the room temperature is below +25° F the jumper wire should be removed.
9. When the system is operating, check the supply voltage. The voltage must be within +/- 10 percent of the voltage marked on the unit nameplate and the phase to phase unbalance should be 2 percent or less.
10. Check the room thermostat setting and be sure it functions properly.



Three-Way Valve Operation

(F0) Units



TRS low temp air handling units have an Apollo (F0) or Belimo (F1) three way actuating valve. In standard operation conditions, this is in a normally closed position. When there is frost present on the coil surface and after the heater contactor is turned on, the actuator will energize. This places the valve in an open position diverting the flow of fluid around the coils and starts the defrost cycle. Duration is dictated by the thermostat placed inside the control panel. Actuating valve should be properly factory calibrated. If this is not calibrated, contact TRS for more information before any work is performed.

Manually Adjust Electric Actuators

Control the closed position of the valve using the top switch and cam

1. Adjust the closed position by setting the top switch first.
2. Rotate the override shaft until the actuator is closed.
3. Adjust the upper cam until the flat of the cam is resting on the lever of the limit switch.
4. Rotate the cam counterclockwise until the switch clicks (corresponding to activation of the switch), then rotate the cam clockwise until the switch clicks again.
5. Hold this position and tighten the set screw on the cam.

Control the closed position of the valve using the bottom switch and cam

1. Adjust the open position by setting the bottom switch.
2. Rotate the override shaft until the actuator is open.
3. Adjust the lower cam until the flat of the cam is resting on the lever of the limit switch.
4. Rotate the cam clockwise until the switch clicks (corresponding to activation of the switch), then rotate the cam counterclockwise until the switch clicks again.
5. Hold this position and tighten the set screw on the cam.

Rotate the actuator without power

Press down on the override shaft connected to the actuator gear box and rotate the shaft by hand.

(F1) Units - Bypass Valve Positions

Figure 2. Spring closed position (bypass cycle)



Figure 3. Powered open position (cooling cycle)





Thermostat

(F0) Units

Each AHU is equipped with a Danfoss thermostat allowing the user to set a desired low setpoint (LSP). The user can set the correct differential in the unit by adjusting the differential value and highest setpoint (HSP) for the application. See below for how to use the adjustment knob and differential spindle on a thermostat.

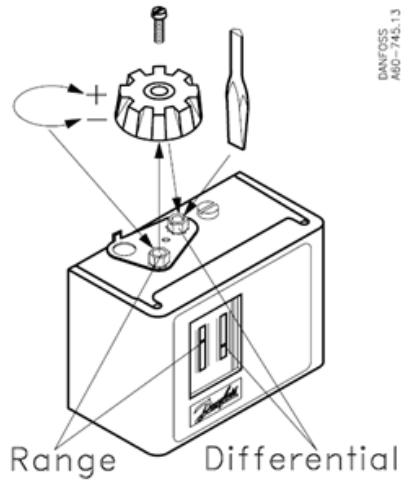
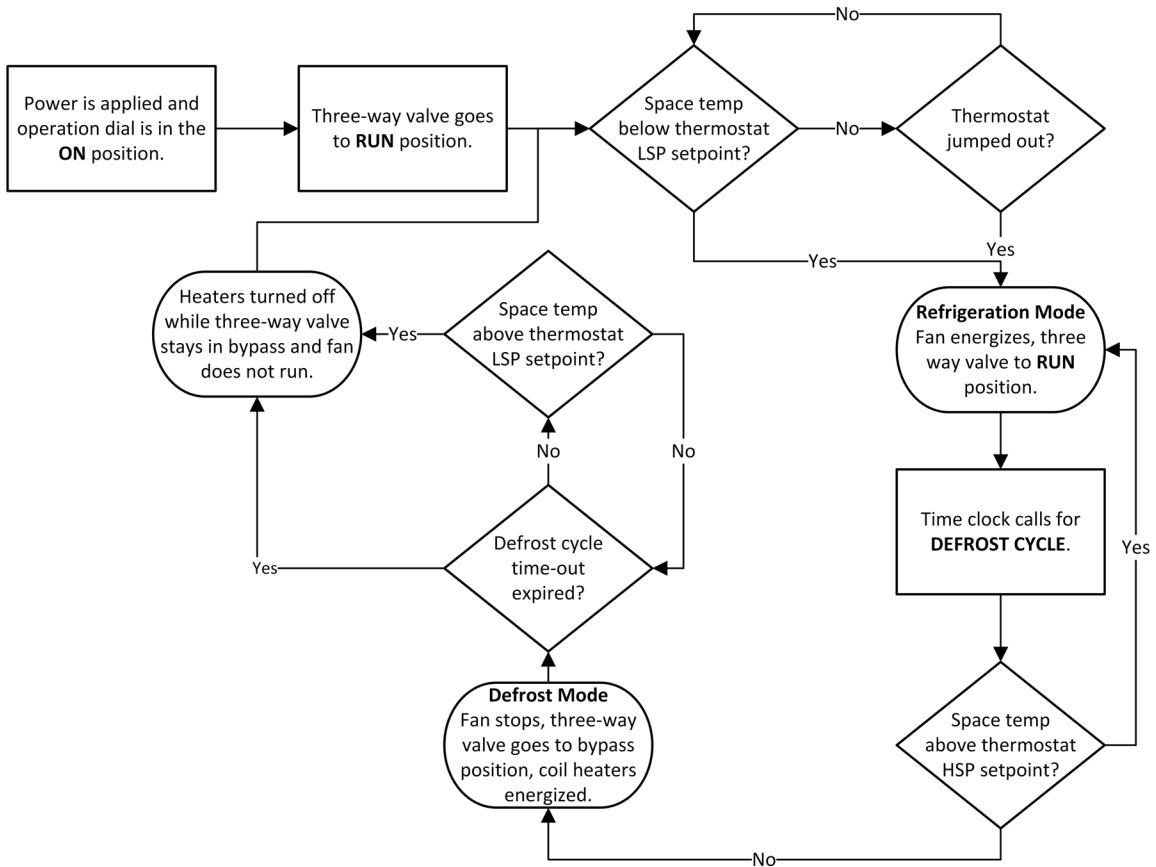

Table 1 Equations to establish the differential

High setpoint minus Differential equals low setpoint
$HSP - DIFF = LSP$
$45^{\circ} F (7^{\circ} C) - 10^{\circ} F (5^{\circ} C) = 35^{\circ} F (2^{\circ} C)$

Figure 4. Thermostat sequence of operation schematic



(F1) Units

The PENNA421 electronic temperature control is a 120v SPDT thermostat with a simple on/off setpoint of -40° to 212° F and a built in anti-short cycle delay that is factory set at 0 (disabled). The temperature sensor is mounted in the return filter door. The touch pad has three buttons for setup and adjustments. The basic menu allows for quick adjustment of ON and OFF temperature values, as well as the Sensor Failure mode (SF) and Anti-Short Cycle Delay (ASd) value.

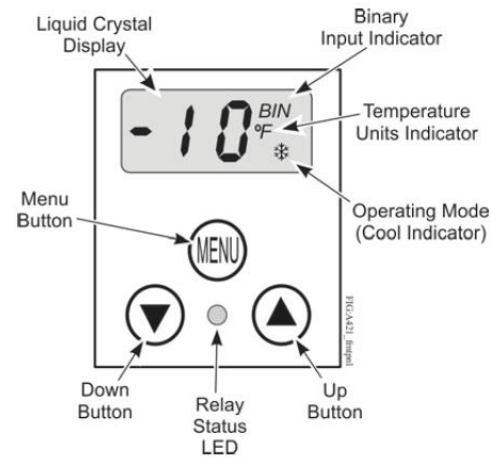

Table 2. Fault codes defined

Fault Code	Definition	System Status	Solution
SF flashing alternately with OP	Open temperature sensor or sensor wiring	Output functions according to the selected sensor failure mode (SF)	See Troubleshooting Procedure. Cycle power to reset the control.
SF flashing alternately with SH	Shorted temperature sensor or sensor wiring	Output functions according to the selected sensor failure mode (SF)	See Troubleshooting Procedure. Cycle power to reset the control.
EE	Program failure	Output is off	Reset control by pressing the MENU button. If problems persist, replace the control.

Change the Temperature Setpoint:

1. Select **MENU** until the LCD displays **OFF**.
2. Select **MENU** until the LCD now displays the **OFF** setpoint temperature.
3. Select **OR** to change the value (**OFF** temperature is the desired room temperature).
4. When the desired value is reached select **MENU** to store the value. (indent) The LCD will now display **ON**.
5. Select **MENU** and the LCD will display the **ON** setpoint temperature.
6. Select **OR** to change value and select **MENU** to save.
7. After 30 seconds the controller will divert back to the home screen and display the room temperature.

Note: When the green relay status LED is illuminated the thermostat is calling for cooling (a snowflake symbol will also appear).

EXAMPLE: To maintain room temperature of 5° F, set the **OFF** to 4° and set the **ON** to 5°.

Defrost Control Instructions

(F0) Units

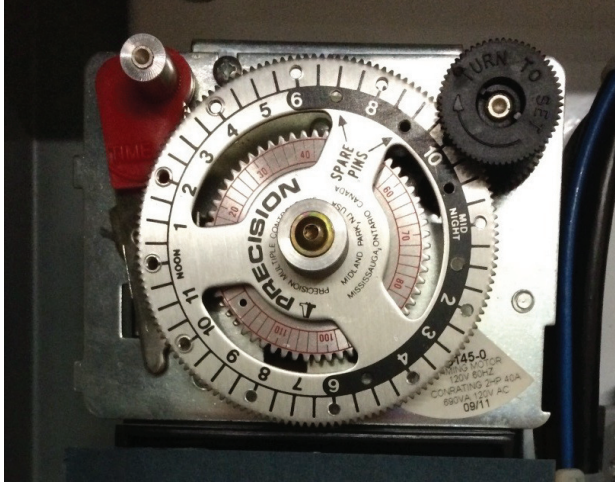

Dial Description

Two simplified dials control defrost cycle initiation and duration. The outer dial rotates once every 24 hours to establish cycle initiation. It is calibrated in hours 1-24 and accepts timer pins which are inserted opposite desired cycle initiation times. Up to 6 defrost cycles are obtainable in a 24 hour period.

The inner dial controls the duration of each defrost cycle and rotates once every 2 hours. It is calibrated in 2 minute increments up to 110 minutes and has a hand set pointer which indicates the length of the cycle in minutes. This timer also has a solenoid which is activated by a thermostat or pressure switch to terminate defrost.

To Set Timer

1. Screw timer pins in outer dial at desired starting time.
2. Press in on bronze pointer on inner dial and slide it to indicate cycle length in minutes.
3. Turn time setting knob until time of day pointer is pointing to.
4. The number on outer dial corresponding to actual time of day at that moment.

(F1) Units

The electric defrost is initiated by an ABB multi-function timer (see image for factory settings). The defrost cycle allows the coil to clear of all frost before returning to the cooling cycle. If this does not occur the timer settings may need to be adjusted. For changing the settings see the section below on TIMERS. The cooling times and defrost times are preset but may need to be adjusted depending on the job specific conditions.

- The two timers on the left provide a delay between VFD and soft start fan selection.

Important: Do not change the settings on the two timers on the left to avoid harm to the VFD or soft start.

- The third timer from the left controls length of the cooling cycle run time.
- The far-right timer controls the length of defrost cycle run time.

EXAMPLE: Change the cooling cycle from 50 minutes to 10 hours with a 30 minute defrost cycle. This will achieve approximately two defrost periods of 30 minutes in a 24-hour period.

1. On the third timer from the left change the Time selector to **10h** and the Time value to **10** (sets cooling cycle to 10 hours).
2. On the fourth timer from the left change the Time value to **3** (sets defrost cycle to 30 minutes).

For a more detailed description of the timer functions see the timer manual located in the inside the control panel.

See below for typical Lead/Follow mode timer settings for 50 minute cool cycle and 20 minute defrost cycle.



Trane - by Trane Technologies (NYSE: TT), a global climate innovator - creates comfortable, energy efficient indoor environments for commercial and residential applications. For more information, please visit trane.com or tranetechnologies.com.

Trane has a policy of continuous product and product data improvement and reserves the right to change design and specifications without notice. We are committed to using environmentally conscious print practices.