



Installation Instructions

E50 Series

Compact Power and Energy Meters BACnet® (E50H2A-T2) and Modbus (E50C2A-T2) for use only with E683 Series Rope CT



PN: X13690276001 PN: X13690277001



X39641309001

SAFETY WARNING

Only qualified personnel should install and service the equipment. The installation, starting up, and servicing of heating, ventilating, and air-conditioning equipment can be hazardous and requires specific knowledge and training. Improperly installed, adjusted or altered equipment by an unqualified person could result in death or serious injury. When working on the equipment, observe all precautions in the literature and on the tags, stickers, and labels that are attached to the equipment.

April 2021

BAS-SVX081D-EN

©2021 Trane



1 Warnings, Cautions, and Notices

Read this manual thoroughly before operating or servicing this unit. Safety advisories appear throughout this manual as required. Your personal safety and the proper operation of this machine depend upon the strict observance of these precautions.

The three types of advisories are defined as follows:

WARNING Indicates a potentially hazardous situation which, if not avoided, could result in death or serious injury.

CAUTION Indicates a potentially hazardous situation which, if not avoided, could result in minor or moderate injury. It could also be used to alert against unsafe

NOTICE Indicates a situation that could result in equipment or property-damage only accidents.

Important Environmental Concerns

Scientific research has shown that certain man-made chemicals can affect the earth's naturally occurring stratospheric ozone layer when released to the atmosphere. In particular, several of the identified chemicals that may affect the ozone layer are refrigerants that contain Chlorine, Fluorine and Carbon (CFCs) and those containing Hydrogen, Chlorine, Fluorine and Carbon (HCFCs). Not all refrigerants containing these compounds have the same potential impact to the environment. Trane advocates the responsible handling of all refrigerants-including industry replacements for CFCs such as HCFCs and HFCs.

Important Responsible Refrigerant Practices

Trane believes that responsible refrigerant practices are important to the environment, our customers, and the air conditioning industry. All technicians who handle refrigerants must be certified according to local rules. For the USA, the Federal Clean Air Act (Section 608) sets forth the requirements for handling, reclaiming, recovering and recycling of certain refrigerants and the equipment that is used in these service procedures. In addition, some states or municipalities may have additional requirements that must also be adhered to for responsible management of refrigerants. Know the applicable laws and follow them.

2 Warnings

WARNING

Proper Field Wiring and Grounding Required!
Failure to follow code could result in death or serious injury. All field wiring MUST be performed by qualified personnel. Improperly installed and grounded field wiring poses FIRE and ELECTROCUTION hazards. To avoid these hazards, you MUST follow requirements for field wiring installation and grounding as described in NEC and your local/state electrical codes.

WARNING

Personal Protective Equipment (PPE) Required!
Failure to wear proper PPE for the job being undertaken could result in death or serious injury. Technicians, in order to protect themselves from potential electrical, mechanical, and chemical hazards, MUST follow precautions in this manual and on the tags, stickers, and labels, as well as the instructions below:

- Before installing/servicing this unit, technicians MUST put on all PPE required for the work being undertaken (Examples; cut resistant gloves/sleeves, butyl gloves, safety glasses, hard hat/bump cap, fall protection, electrical PPE and arc flash clothing). ALWAYS refer to appropriate Safety Data Sheets (SDS) and OSHA guidelines for proper PPE.
- When working with or around hazardous chemicals, ALWAYS refer to the appropriate SDS and OSHA/GHS (Global Harmonized System of Classification and Labeling of Chemicals) guidelines for information on allowable personal exposure levels, proper respiratory protection and handling instructions.

If there is a risk of energized electrical contact, arc, or flash, technicians MUST put on all PPE in accordance with OSHA, NFPA 70E, or other country-specific requirements for arc flash protection, PRIOR to servicing the unit. NEVER PERFORM ANY SWITCHING, DISCONNECTING, OR VOLTAGE TESTING WITHOUT PROPER ELECTRICAL PPE AND ARC FLASH CLOTHING. ENSURE ELECTRICAL METERS AND EQUIPMENT ARE PROPERLY RATED FOR INTENDED VOLTAGE.

3 Warnings

WARNING

Follow EHS Policies!
Failure to follow instructions below could result in death or serious injury.

- All Trane personnel must follow the company's Environmental, Health and Safety (EHS) policies when performing work such as hot work, electrical, fall protection, lockout/tagout, refrigerant handling, etc. Where local regulations are more stringent than these policies, those regulations supersede these policies.
- Non-Trane personnel should always follow local regulations.

WARNING

Hazard of Electrical Shock, Explosion, or Arc Flash!
Failure to follow these instructions could result in death or serious injury. Install the product in an appropriate electrical/fire enclosure per local regulations. Do not use the product for life or safety applications. Do not install the product in hazardous or classified locations. Do not exceed the product ratings or maximum limits. Products rated only for basic insulation must be installed on insulated conductors. Current transformer secondaries (current mode) must be shorted or connected to a burden at all times. Remove all wire scraps, tools, replace all doors, covers and protective devices before powering the equipment.

WARNING

Hazardous Voltage!
Failure to disconnect power before servicing could result in death or serious injury. Disconnect all electric power, including remote disconnects before servicing. Follow proper lockout/tagout procedures to ensure the power can not be inadvertently energized.

Copyright

This document and the information in it are the property of Trane, and may not be used or reproduced in whole or in part without written permission. Trane reserves the right to revise this publication at any time, and to make changes to its content without obligation to notify any person of such revision or change.

4 Trademarks

All trademarks referenced in this document are the trademarks of their respective owners.

Specifications

Measurement Accuracy:	Real Power and Energy: IEC 62053-22 Class 0.5S, ANSI C12.20 0.5%
Input Voltage Characteristics:	Measured AC Voltage: Minimum 90V _{L-N} (156V _{L-L}) for stated accuracy U.L. Maximum: 600V _{L-L} (347V _{L-N}) CE Maximum: 300V _{L-N} Impedance: 10.4 kΩ Frequency Range: 45 Hz to 65 Hz
Input Current Characteristics:	Measurement Input Range: Only with E683 Series Rope-style CTs Impedance: 10.6 kΩ (1/3 V mode) or 32.1 kΩ (1 V mode)
Control Power:	AC: 5 VA maximum, 90V minimum U.L. Maximum: 600V _{L-L} (347V _{L-N}) CE Maximum: 300V _{L-N} DC: 3W maximum External DC current limiting required. Refer to fuse recommendation U.L. and CE: 125 Vdc to 300 Vdc Ride-through Time: 100 ms @120 Vac
Mechanical Characteristics:	IP Degree of Protection (IEC60529): IP40 front display; IP20 Meter Terminal Block Screw Torque: 0.37 ft-lb (0.5 Nm) nominal/0.44 ft-lb (0.6 Nm) maximum Terminal Block Wire Size: 24 AWG to 14 AWG (0.2 to 2.1 mm ²) Rail: T35 (35 mm) DIN Rail per EN50022
Operating Conditions:	Operating Temp: -30°C to 70°C (-22°F to 158°F) Storage Temp: -40° to 85°C (-40° to 185°F) Humidity Range: <95% RH (non-condensing) Altitude of Operation: 3 km maximum
Metering Category:	North America: CAT III; for distribution systems up to 347 V L-N/600 Vac L-L CE: CAT III; for distribution systems up to 300 V _{L-N} Dielectric Withstand: Per U.L. 508, EN61010 Conducted/Radiated Emissions: FCC part 15 Class B, EN55011/EN61000 Class B (residential and light industrial) Conducted/Radiated Immunity: EN61000 Class A (heavy industrial)
Agency Approvals:	U.S./Canada (cULus): UL508 (open type device)/CSA 22.2 No. 14-05 Europe (CE): EN61010-1

5 Dimensions

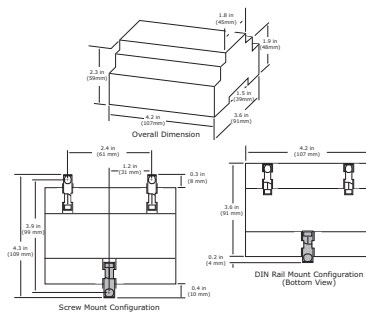

Guidelines

- Disconnect power prior to installation.
- Reinstall any covers displaced during installation before re-powering unit.
- Mount the meter in an appropriate electrical enclosure near equipment to be monitored.
- Do not install the load side of a variable frequency drive (VFD).

Installation

Mount the meter using one of the following two methods:

DIN Rail Mount

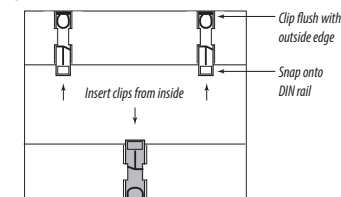

1. Attach mounting clips to the underside of housing by sliding them into the slots from the inside.
Note: The stopping pegs must face the housing and the outside edge of the clip

6 must be flush with the outside edge of the housing.

2. Snap the clips onto the DIN rail.
Note: Use 2-end stop clips to reduce the unit from shifting horizontally across the DIN rail.

Screw Mount

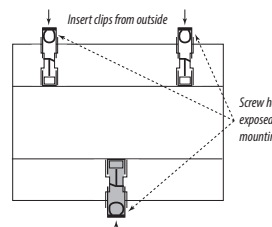

1. Attach mounting clips to the underside of the housing by sliding them into the slots from the outside.
Note: The stopping pegs must face the housing and the screw hole must be exposed on the outside of the housing.

2. Use three (3) #8 screws (not supplied) to mount the meter to the back of enclosure.

Supported Systems

The meter has a number of different possible system wiring configurations (Refer to the table below and next section, Wiring Diagrams).

To configure the meter, set the System Type via the User Interface, Modbus register 130 (E50C2-T2) or BACnet Analog Value Object AV2 (E50H2-T2). The system type tells the meter which of its current and voltage inputs are valid, which are to be ignored, and if neutral is connected. Setting the correct system type prevents unwanted energy accumulation on unused inputs, selects the formula to calculate the Theoretical Maximum System Power, and determines which phase loss algorithm is to be used. The phase loss algorithm is configured as a percent of the Line-to-Line System Voltage (except when in System Type 10). In addition, it calculates the expected Line-to-Neutral voltages for system types that have Neutral (12 & 40). Values that are not valid in a particular System Type display as ---- on the User Interface or as QNAN in the Modbus registers or BACnet Analog Input objects.

Note: To avoid distortion, use parallel wires for control power and voltage inputs.

# Wires	Qty	CTs	Voltage Connections	System Type	Phase Loss Measurement			Wiring Diagram		
					VLL	VLN	Balance			
Single-Phase Wiring										
2	1	A	2	A,N	L-N	10	1L+1n	AN	1	
2	1	A	2	A,B	L-L	11	2L	AB	2	
3	2	A,B	3	A,B,N	L-L w/N	12	2L+1n	AB, AN, AB	3	
Three-Phase Wiring										
3	3	A,B,C	3	A,B,C	Delta	31	3L	AB, BC, CA	4	
4	3	A,B,C	4	A,B,C,N	Grounded Wye	40	3L-1n	AB, BC, CA, AN, BN, CN	AN-BN-CN and AB-BC-CA	5,6

Refer to the following symbols used in the wiring diagrams.

	Voltage Disconnect Switch
	Fuse (not included with meter) Note: Installer is responsible for ensuring compliance with local requirements.
	Earth Ground
	Current Transducer (CT)
	Potential Transformer
	Protection containing a voltage disconnect switch with a fuse or disconnect circuit breaker. The protection device must be rated for the available short circuit current at the connection point.

NOTICE

Equipment Damage!

Failure to follow this warning could result in overheating and permanent equipment damage. This product is designed only for use with 1 V or 0.333 V current transducers. Do Not Use Current Output CTs ON This Product.

WARNING

Hazardous Voltage and Equipment Damage!

Failure to disconnect power before servicing could result in death or serious injury. Disconnect all electric power, including remote disconnects before servicing. CT terminals are referenced to neutral on the meter and may be at elevated voltages. Do not contact meter terminals while the unit is connected. Do not connect or short other circuits to the CT terminals.

Product Diagram

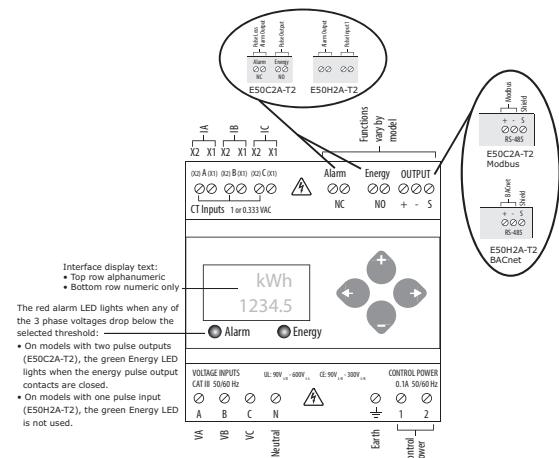

RS-485 Communication (E50C2A-T2 and E50H2A-T2)

Below shows a daisy chain of devices to the power meter. The RS-485 secondary port allows the power meter to be connected in a daisy chain with up to 63, 2-wire devices.

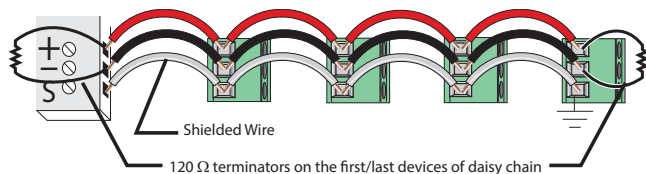

- Notes:
- The voltage and current ratings on the terminals are compliant with the requirements of the EIA RS-485 communications standard.
 - The RS-485 transceivers are 1/4 unit load or less.
 - RS-485+ has a 47 kΩ pull up to +5V, and RS-485- has a 47 kΩ pull down to Shield (RS-485 signal ground).
 - Wire the RS-485 Bus as a daisy chain from device-to-device, without any stubs. Use 120 Ω termination resistors at each end of the bus (not included).
 - Shield is not internally connected to Earth Ground.
 - Connect Shield to Earth Ground somewhere on the RS-485 bus (only at one point).

- For all terminals on E5x meters:
- When tightening terminals, apply the correct torque: 0.37-0.44 ft-lb (0.5-0.6 N-m).
 - Use 14-24 gauge (2.1-0.2 mm²) wire.

Display Screen

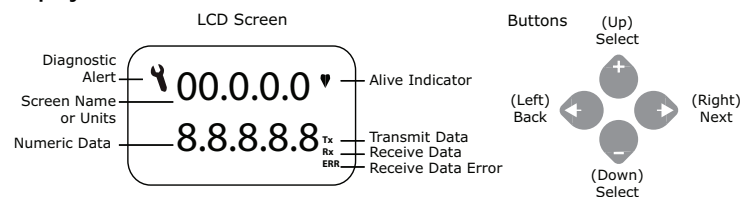

Wiring CT

- Connect the CT output leads to the meter inputs. The white wire is the X1 lead. The E683 CT has an arrow indicating the source side.
- Release the clasp on one side of the CT and open it on the hinge.
- Fit the Rogowski coil around the conductor, bringing the coil ends together.
- Lock the coil by turning the ring clockwise as shown below.
- Reconnect power to the panel.



Wiring Diagrams

The current transducers are not polarity sensitive for all E50 models. It is not necessary to observe CT orientation.

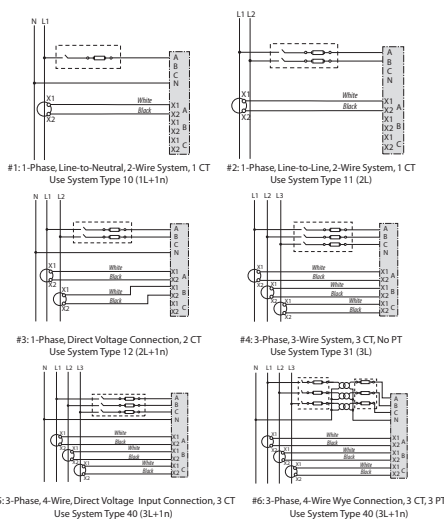

Control Power

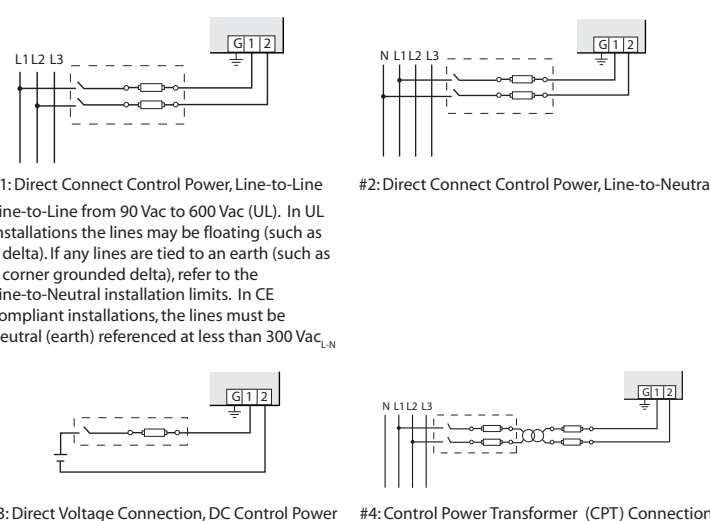

Fuse Recommendations

- Keep the fuses close to the power source.
- For selecting fuses and circuit breakers, use the following criteria:
- Select current interrupt capacity based on the installation category and fault current capability.
 - Select over-current protection with a time delay.
 - Use a voltage rating sufficient for the input voltage applied.
 - Provide over-current protection and disconnecting means to protect the wiring. For AC installations, use Trane AH04 or equivalent. For DC installations, provide external circuit protection.
 - Suggested: 0.5A, time delay fuses rated for DC operation at or above the supply voltage.
 - Use the earth connection (G) for electromagnetic compatibility (EMC), not a protective earth ground.

Pulse Contact Inputs (E50H2A-T2 Only)

The E50H2A-T2 has one input with pulse accumulators for solid state or mechanical contacts in other sensors, such as water or gas flow meters. This input is isolated from the measured circuits. On models with BACnet® communication (E50H2A-T2), it is referenced to the communication signal ground and the comm output shield terminal. Use with contacts that do not require current to remove oxidation.

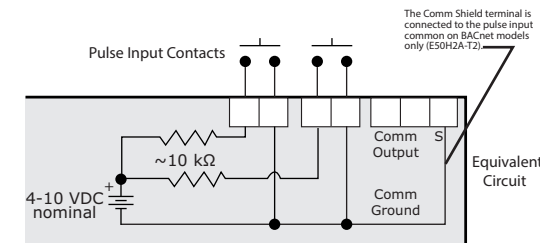

Solid State Pulse Outputs (E50C2A-T2 and E50H2A-T2)

The E50C2A-T2 has one normally open (N.O.) KY Form A output and one normally closed (N.C.) output. One is dedicated to energy (Wh), and the other to Alarm. See the Setup section for configuration information. The E50H2A-T2 has an Alarm output, but no energy pulse outputs.

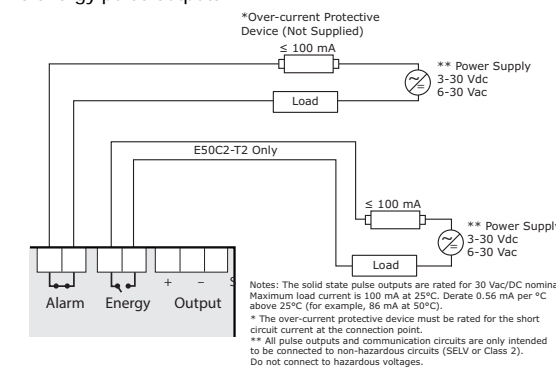

Navigating Screens and Setting Parameters

These instructions assume the meter shipped with factory default settings. If it has been previously configured, all optional values should be checked.

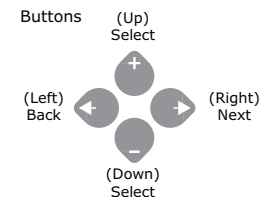

Navigate Setup Screen

- Press + or - repeatedly until the **SETUP** screen displays.
- Press -> to advance to the **S COM** (Set Communications) setup screen.
- Press -> to advance to the **ADDR** screen and through the address digits. Press + or - to select the Modbus address (default is **001**).
- Press -> to accept the value and advance to the **BAUD** screen. Press + or - to select the baud rate (default is **19200**).
- Press -> to advance to the **PAR** screen. Press + or - to select the parity (default is **NONE**).
- Press -> to return to the **S COM** screen.

Enter Modbus Communication Parameters (for E50C2A-T2 Only)

- Press + or - repeatedly until the **SETUP** screen displays.
- Press -> to advance to the **S COM** (Set Communications) setup screen.
- Press -> to advance to the **ADDR** screen and through the address digits. Press + or - to select the Modbus address (default is **001**).
- Press -> to accept the value and advance to the **BAUD** screen. Press + or - to select the baud rate (default is **19200**).
- Press -> to advance to the **PAR** screen. Press + or - to select the parity (default is **NONE**).
- Press -> to return to the **S COM** screen.

Enter BACnet® Communication Parameters (for E50H2A-T2 Only)

- Press + or - repeatedly until the **SETUP** screen displays.
- Press -> to advance to the **MAC** screen and through the address digits. Press + or - to select the BACnet® MAC address (default is **001**).
- Press -> to accept the value and advance to the **KBAUD** screen. Press + or - to select the baud rate (default is **76.8k**).
- Press -> to advance to the **ID1** screen and through the upper four digits of the Device Instance. Press + or - to select the ID digits (default is a **pseudo-random number**).
- Press -> to accept the value and advance to the **ID2** screen and through the lower three digits of the Device Instance. Press + or - to select the ID digits (default is a **pseudo-random number**).
- Press -> to accept the value and return to the **S BAC** screen.

Enter CT Output Voltage and Input Current Ranges

- Press + or - repeatedly until the **SETUP** screen displays.
- Press -> to advance to the **S CT** (Set Current Transducer) setup screen.
- Press -> to advance to the **CT V** screen. Press + or - to select the voltage mode current transducer output voltage (default is **1.00**).
- Press -> to advance to the **CT SZ** screen and through the digits. Press + or - to select the CT size in amps (default is **100**).
- Press -> to accept the value and return to the **S CT** screen.

Enter the Service Type to Monitor

- Press + or - repeatedly until the **SETUP** screen displays.
- Press -> to advance to the **S SYS** (Set System) setup screen.
- Press -> to advance to the **SYSTEM** screen. Press + or - to select the configuration (refer to the Wiring Diagrams section, diagrams #5 and #6 for 3L-1N).
- Press -> to return to the **S SYS** screen.

China RoHS Compliance Information

Hazardous Substances						
Part Name	Pb	Hg	Cd	Cr, VI	PBB	PBDE
Electronic	X ^(a)	O ^(b)	O	O	O	O

- (a) X indicates that concentration of hazardous substance in at least one of the homogeneous materials used for this part is above the limit as stipulated in GB/T 26572.
- (b) O indicates that the concentration of hazardous substance in all of the homogeneous materials for this part is below the limit as stipulated in GB/T 26572.

Additional Resources

- Compact Power and Energy Meters E50H2A-T2 for BACnet MS-TP Support (E683 CT), Installation, Operation, and Troubleshooting, BAS-SVX071.
- Compact Power and Energy Meters E50C2A-T2 for Modbus Support (E683 CT), Installation, Operation, and Troubleshooting, BAS-SVX072.
- Quick Installation Guide, Z207411-0A 0217.



Trane - by Trane Technologies (NYSE: TT), a global climate innovator - creates comfortable, energy efficient indoor environments for commercial and residential applications. For more information, please visit tranetechnologies.com.

Trane has a policy of continuous product and product data improvement and reserves the right to change design and specifications without notice. We are committed to using environmentally conscious print practices.