



Installation Instructions

Symbio™ 500 Programmable Controller

The Symbio 500 multi-purpose programmable controller is used in a range of terminal applications.

SAFETY WARNING

Only qualified personnel should install and service the equipment. The installation, starting up, and servicing of heating, ventilating, and air-conditioning equipment can be hazardous and requires specific knowledge and training. Improperly installed, adjusted or altered equipment by an unqualified person could result in death or serious injury. When working on the equipment, observe all precautions in the literature and on the tags, stickers, and labels that are attached to the equipment.

April 2022

BAS-SVN231C-EN
©2023 Trane



4 Storage/Operating Specifications

Storage	
Temperature:	-67°F to 203°F (-55°C to 95°C)
Relative Humidity:	Between 5% to 95% (non-condensing)
Operating	
Temperature:	-40°F to 158°F (-40°C to 70°C)
Humidity:	Between 5% to 95% (non-condensing)
Power:	20.4–27.6 Vac (24 Vac, ±15% nominal) 50–60 Hz, 24 VA For specifics on transformer sizing, see BAS-SVX090.
Mounting Weight of Controller:	Mounting surface must support 0.80 lb. (0.364 kg)
Environmental Rating (Enclosure):	NEMA 1
Plenum Rating:	Not plenum rated. The Symbio 500 must be mounted withing a rated enclosure when installed in a plenum.

Agency Compliance

- UL60730-1 PAZX (Open Energy Management Equipment)
- UL94-5V Flammability
- CE Marked
- UKCA Marked
- FCC Part 15, Subpart B, Class B Limit
- VCCI-CISPR 32:2016: Class B Limit
- AS/NZS CISPR 32:2015: Class B Limit
- CAN ICES-003(B)/NMB-003(B)

1 Warnings, Cautions, and Notices

Read this manual thoroughly before operating or servicing this unit. Safety advisories appear throughout this manual as required. Your personal safety and the proper operation of this machine depend upon the strict observance of these precautions.

The three types of advisories are defined as follows:

- WARNING** Indicates a potentially hazardous situation which, if not avoided, could result in death or serious injury.
- CAUTION** Indicates a potentially hazardous situation which, if not avoided, could result in minor or moderate injury. It could also be used to alert against unsafe practices.
- NOTICE** Indicates a situation that could result in equipment or property-damage only accidents.

Important Environmental Concerns

Scientific research has shown that certain man-made chemicals can affect the earth's naturally occurring stratospheric ozone layer when released to the atmosphere. In particular, several of the identified chemicals that may affect the ozone layer are refrigerants that contain Chlorine, Fluorine and Carbon (CFCs) and those containing Hydrogen, Chlorine, Fluorine and Carbon (HCFCs). Not all refrigerants containing these compounds have the same potential impact to the environment. Trane advocates the responsible handling of all refrigerants-including industry replacements for CFCs such as HCFCs and HFCs.

Important Responsible Refrigerant Practices

Trane believes that responsible refrigerant practices are important to the environment, our customers, and the air conditioning industry. All technicians who handle refrigerants must be certified according to local rules. For the USA, the Federal Clean Air Act (Section 608) sets forth the requirements for handling, reclaiming, recovering and recycling of certain refrigerants and the equipment that is used in these service procedures. In addition, some states or municipalities may have additional requirements that must also be adhered to for responsible management of refrigerants. Know the applicable laws and follow them.

2 WARNING

Proper Field Wiring and Grounding Required!
Failure to follow code could result in death or serious injury. All field wiring MUST be performed by qualified personnel. Improperly installed and grounded field wiring poses FIRE and ELECTROCUTION hazards. To avoid these hazards, you MUST follow requirements for field wiring installation and grounding as described in NEC and your local/state/national electrical codes.

WARNING

Personal Protective Equipment (PPE) Required!
Failure to wear proper PPE for the job being undertaken could result in death or serious injury. Technicians, in order to protect themselves from potential electrical, mechanical, and chemical hazards, MUST follow precautions in this manual and on the tags, stickers, and labels, as well as the instructions below:

- Before installing/servicing this unit, technicians MUST put on all PPE required for the work being undertaken (Examples; cut resistant gloves/sleeves, butyl gloves, safety glasses, hard hat/bump cap, fall protection, electrical PPE and arc flash clothing). ALWAYS refer to appropriate Safety Data Sheets (SDS) and OSHA guidelines for proper PPE.
- When working with or around hazardous chemicals, ALWAYS refer to the appropriate SDS and OSHA/GHS (Global Harmonized System of Classification and Labeling of Chemicals) guidelines for information on allowable personal exposure levels, proper respiratory protection and handling instructions.
- If there is a risk of energized electrical contact, arc, or flash, technicians MUST put on all PPE in accordance with OSHA, NFPA 70E, or other country-specific requirements for arc flash protection, PRIOR to servicing the unit. NEVER PERFORM ANY SWITCHING, DISCONNECTING, OR VOLTAGE TESTING WITHOUT PROPER ELECTRICAL PPE AND ARC FLASH CLOTHING. ENSURE ELECTRICAL METERS AND EQUIPMENT ARE PROPERLY RATED FOR INTENDED VOLTAGE.

5 Dimensions/Mounting/Removing the Controller

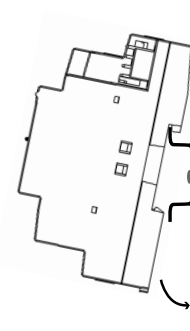
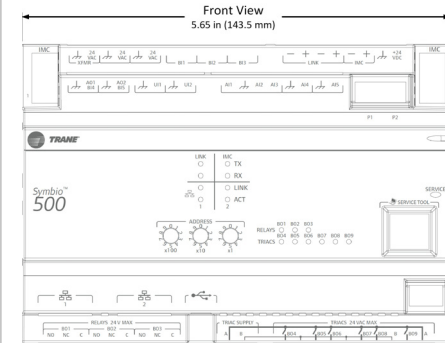

- To mount device:
1. Hook device over top of DIN rail.
 2. Gently push on lower half of device in the direction of arrow until the release clip clicks into place.

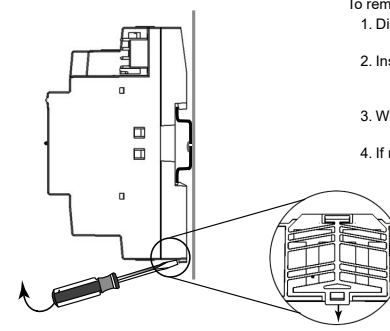

- To remove/reposition device:
1. Disconnect all connectors before removing or repositioning.
 2. Insert screwdriver into slotted release clip and gently pry upward with the screwdriver to disengage the clip.
 3. While holding tension on the clip, lift device upward to remove or reposition.
 4. If repositioned, push on the device until the release clip clicks back into place to secure the device on the DIN rail.

Slotted release clip shown from back side

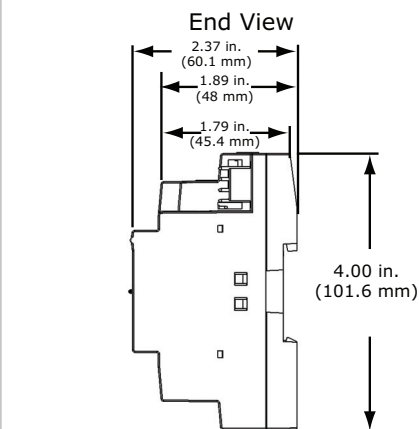

NOTICE

Equipment Damage!
Do not use excessive force to install the controller on the DIN rail. Excessive force could result in damage to the plastic enclosure. If using another manufacturer's DIN rail, follow their recommended installation.

WARNING

Hazard Voltage!
Disconnect all electric power, including remote disconnects, before servicing. Follow proper lockout/tag out procedures to ensure the power cannot be inadvertently energized. Failure to disconnect power before servicing could result in serious injury or death.

CAUTION

Personal Injury and Equipment Damage!
After installation, ensure to check that the 24 Vac transformer is grounded through the controller. Failure to check could result in personal injury and/or damage to equipment. Measure the voltage between chassis ground and any ground terminal on the controller. Expected result: Vac ≤4.0 volt.

3 WARNING

Follow EHS Policies!
Failure to follow instructions below could result in death or serious injury.

- All Trane personnel must follow the company's Environmental, Health and Safety (EHS) policies when performing work such as hot work, electrical, fall protection, lockout/tagout, refrigerant handling, etc. Where local regulations are more stringent than these policies, those regulations supersede these policies.
- Non-Trane personnel should always follow local regulations.

Copyright

This document and the information in it are the property of Trane, and may not be used or reproduced in whole or in part without written permission. Trane reserves the right to revise this publication at any time, and to make changes to its content without obligation to notify any person of such revision or change.

Trademarks

All trademarks referenced in this document are the trademarks of their respective owners.

Ordering Numbers

Order Number	Description
BMSY500AAA0100011	Symbio 500 Programmable Controller
BMSY500UAA0100011	Symbio 500 Programmable Controller, Made in USA

6 Wiring Requirements

To ensure proper operation of the controller, install the power supply circuit in accordance with the following guidelines:

- The controller must receive AC power from a dedicated power circuit; failure to comply may cause the controller to malfunction.
- A dedicated power circuit disconnect switch must be near the controller, easily accessible by the operator, and marked as the disconnecting device for the controller.
- DO NOT run AC power wires in the same wire bundle with input/output wires; failure to comply may cause the controller to malfunction due to electrical noise.
- 18 AWG copper wire is recommended for the circuit between the transformer and the controller.

Transformer Recommendations

The controller can be powered with 24 Vac. Use of a 24 Vac power supply is recommended in order to use the spare 24 Vac outputs for powering relays and TRIACs.

- AC transformer requirements: UL listed, Class 2 power transformer, 24 Vac ±15%, device max load 24 VA. The transformer must be sized to provide adequate power to the controller and outputs.
- CE-compliant installations: The transformer must be CE marked and SELV compliant per IEC standards.

NOTICE

Equipment Damage!
Sharing 24 Vac power between controllers could result in equipment damage.

A separate transformer is recommended for each controller. The line input to the transformer must be equipped with a circuit breaker sized to handle the maximum transformer line current. If a single transformer is shared by multiple controllers:

- The transformer must have sufficient capacity
- Polarity must be maintained for every controller powered by the transformer

Important: If a technician inadvertently reverses polarity between controllers powered by the same transformer, a difference of 24 Vac will occur between the grounds of each controller. The following symptoms could result:

- Partial or full loss of communication on the entire BACnet® link
- Improper function of controller outputs
- Damage to the transformer or a blown transformer fuse

Wiring AC Power

To wire AC power:

1. Connect both secondary wires from the 24 Vac transformer to the XFMR terminals on the device.
2. Ensure the device is properly grounded.

Important: This device must be grounded for proper operation! The factory-supplied ground wire must be connected from any chassis ground connection on the device (⊕) to an appropriate earth ground (⊕). The chassis ground connection used may be the 24 Vac transformer input at the device, or any other chassis ground connection on the device.

Note: The device is not grounded through the DIN rail connection.

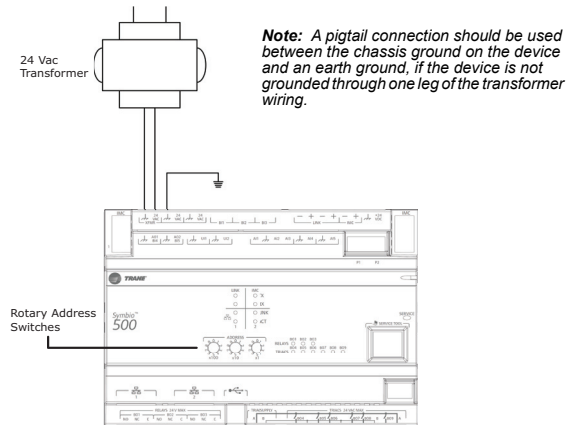

Startup and Power Check

1. Verify that the 24 Vac connector and the chassis ground are properly wired.
2. Each device must have a unique and valid address. The address is set by using the rotary address switches. Valid addresses are 001 through 127 for BACnet MS/TP applications and 001 through 980 for Trane Air-Fi and BACnet IP applications.

Important: A duplicate address or a 000 address will cause communication problems in a BACnet link: The Tracer SC+ will not discover all devices on the link and the installation process will fail after discovery.

3. Remove the lockout/tagout from the line voltage power to the electrical cabinet.
4. Apply power to the controller and observe the power check sequence that follows:

The power LED lights red for 1 second. Then it changes to green, indicating that the unit is properly booted and ready for application code. Flashing red indicates that a fault conditions exists. The Tracer® TU service tool can be used to check for fault conditions after application code and TGP2 programming have been loaded.

Input/Output Wiring

NOTICE

Equipment Damage!
Remove power to the controller before making input/output connections. Failure to do so may cause damage to the controller, power transformer, or input/output devices due to inadvertent connections to power circuits.

Pre-power checks of input/output devices should be performed according to the Symbio 500 IOM (BAS-SVX090). Maximum wire lengths are as follows:

Maximum Wire Lengths		
Type	Inputs	Outputs
Binary	1,000 ft (300 m)	1,000 ft (300 m)
0–20 mA	1,000 ft (300 m)	1,000 ft (300 m)
0–10 Vdc	300 ft (100 m)	300 ft (100 m)
Thermistor/Resistive	300 ft (100 m)	Not Applicable

- All wiring must be in accordance with the NEC and local codes.
- Use only 18–22 AWG (1.02 mm to 0.65 mm diameter), stranded, tinned-copper, shielded, twisted-pair wire.
- Analog and 24 Vdc output wiring distances are dependent on the receiving unit specifications.
- DO NOT run input/output wires or communication wires in the same wire bundle with AC power wires.

Tug Test for Terminal Connectors

If using terminal connectors for wiring, strip the wires to expose 0.28 in (7 mm) of bare wire. Insert each wire into a terminal connector and tighten the terminal screws. A tug test is recommended after tightening terminal screws to ensure that all wires are secure.

BACnet MS/TP Link Wiring

BACnet MS/TP link wiring must be field-supplied and installed in compliance with NEC and local codes. In addition, the wire must be the following type: low capacitance, 18 gauge, stranded, tinned copper, shielded, twisted pair. Polarity must be maintained between all devices on the link.

BACnet IP Wiring

The Symbio 500 supports BACnet IP. The device requires a category 5E or newer Ethernet cable with an RJ-45 plug connector. The cable can be plugged into either port on the controller.

Examples of Wiring

Analog Input/Output Wiring Terminals Are Top Tier

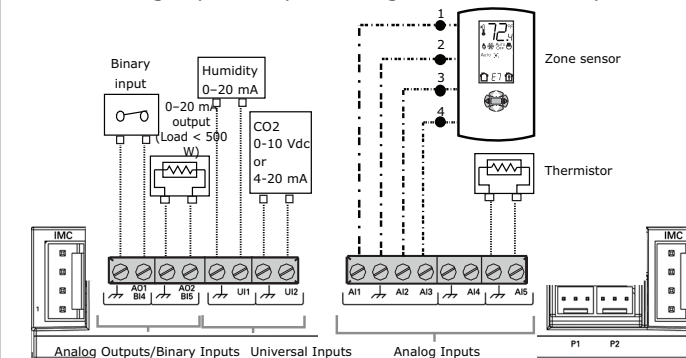

Binary Input/Output Wiring Terminals Are Lower Tier

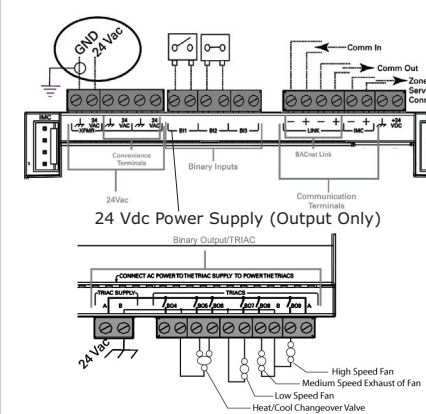

TRIAC Supply Wiring

High-side Switching; typical wiring method

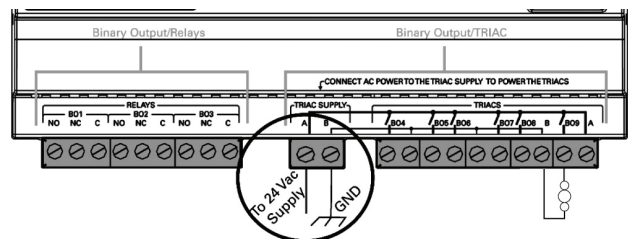

Low-side Switching; minimizes the risk of burning up binary outputs due to inadvertent shorts to the ground.

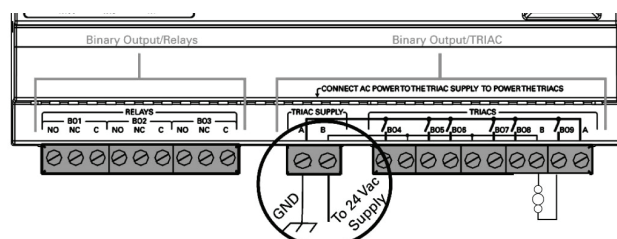

Input/Output Specifications

Input/Output type	Qty	Types	Range	Notes
Analog Input (AI1 to AI5)	5	Thermistor	10kΩ – Type II, 10kΩ – Type III, 2252Ω – Type II, 20kΩ – Type IV, 100 kΩ	These inputs can be configured for timed override capability. Supports *, ** for Trane Zone Sensors.
		RTD	Balco™ (Ni-Fe) 1kΩ, 385 (Pt) 1kΩ, 375 (Pt) 1kΩ, 672 (Ni) 1kΩ.	
		Setpoint (Thumbwheel)	189Ω to 889Ω	
		Resistive	100Ω to 100kΩ	Typically used for fan speed switch.
Universal input (UI1 and UI2)	2	Linear Current	0–20mA	These inputs may be configured to be thermistor or resistive inputs, 0–10 Vdc inputs, or 0–20 mA inputs.
		Linear Voltage	0–10Vdc	
		Thermistor	10kΩ – Type II, 10kΩ – Type III, 2252Ω – Type II, 20kΩ – Type IV, 100 kΩ	
		RTD	Balco™ (Ni-Fe) 1kΩ, 385 (Pt) 1kΩ, 375 (Pt) 1kΩ, 672 (Ni) 1kΩ.	
		Setpoint (Thumbwheel)	189 Ω to 889 Ω	
		Resistive	100Ω to 100kΩ	
Binary input (BI1 to BI3)	3		24 Vac detect	The controller provides the 24Vac that is required to drive the binary inputs when using the recommended connections.
Binary Outputs (BO1 to BO3)	3	Form C Relay	0.5A @ 24Vac pilot duty	Ranges given are per contact. Power needs to be wired to the binary output. All outputs are isolated from each other and from ground or power.
Binary Outputs (BO4 to BO9)	6	Triac	0.5A @ 24Vac resistive and pilot duty	Ranges given are per contact and power comes from the TRIAC SUPPLY circuit. Use for modulating TRIACs. User determines whether closing high side (providing voltage to the grounded load) or low side (providing ground to the power load).
AnalogOutput/BinaryInput (AO1/BI4 and AO2/BI5)	2	Linear Current	0 - 20mA	Each termination must be configured as either an analog output or binary input.
		Linear Voltage	0 - 10Vdc	
		Binary Input	Dry contact	
		Pulse Width Modulation	80 Hz signal @ 15Vdc	
Pressure Inputs (P1 and P12)	2		0 - 5 In H ₂ O	Pressure inputs supplied with 5 volts (designed for Kavlico™ pressure transducers).
Point total	23			

Note: Symbio 500 binary outputs are not compatible with voltages over 24Vac.

Expansion Modules

If additional inputs/outputs are needed, the Symbio 500 will support an additional 110 (133 total) inputs/outputs. See Tracer XM30, XM32, XM70, and XM90 Expansion Modules IOM (BAS-SVX46) for more information.

Wi-Fi Modules

- If Trane Wi-Fi is used, the Symbio 500 supports either module:
- X13651743001 Wi-Fi Field Installed Kit, 1 m cable, 70C
 - X13651743002 Wi-Fi Field Installed Kit, 2.9 m cable, 70C

Trane - by Trane Technologies (NYSE: TT), a global climate innovator - creates comfortable, energy efficient indoor environments for commercial and residential applications. For more information, please visit trane.com or tranetechnologies.com.

Trane has a policy of continuous product and product data improvement and reserves the right to change design and specifications without notice. We are committed to using environmentally conscious print practices.