



Installation Instructions

Tracer Summit™ BMTB Bridge

Order Numbers: BMTB001AAA000,
BMTB001BAA000

June 2020

BAS-SVN204D-EN

© 2020 Trane



1

For more detailed installation instructions refer to the Tracer Communications Bridge - Comm 3/4 to Tracer® SC Setup and Configuration Guide (BAS-SVX64).

Note: Comm 3/4 to Tracer® SC Bridge (Bridge) boards identified with assembly number #64002784 require Bridge Image Version 1.0 and Tracer Summit Version 17 SP12.

All other BMTB Bridges that are connected to the site must be upgraded to the new BCU image at the same time this board is installed. The new BCU images are available to download from the proprietary Trane Intranet software downloads web site. Failure to follow this instruction will result in the BCU board not working.

Warnings, Cautions, and Notices

The three types of advisories are defined as follows:

WARNING Indicates a potentially hazardous situation which, if not avoided, could result in death or serious injury.

CAUTION Indicates a potentially hazardous situation which, if not avoided, could result in minor or moderate injury. It could also be used to alert against unsafe

NOTICE Indicates a situation that could result in equipment or property-damage only accidents.

NOTICE

Avoid Equipment Damage!
Install and use the controller as specified by the manufacturer. Failure to do so may result in equipment damage.

X39641236-01

SAFETY WARNING

Only qualified personnel should install and service the equipment. The installation, starting up, and servicing of heating, ventilating, and air-conditioning equipment can be hazardous and requires specific knowledge and training. Improperly installed, adjusted or altered equipment by an unqualified person could result in death or serious injury. When working on the equipment, observe all precautions in the literature and on the tags, stickers, and labels that are attached to the equipment.

2

Verifying Model Number for Local Power Requirements

Before installing the controller, verify the correct model for local power requirements. The model number is located on the shipping label or on the product label inside the enclosure.

Table 1. BMTB Bridge model numbers

US (120 Vac)	CE (230 Vac)	Description
BMTB001AAA000	BMTB001BAA000	Comm 3/4 to Tracer SC Bridge

Selecting a Mounting Location

Ensure that the location meets the operating environment requirements and clearance requirements described in the following sections. The controller must be installed indoors. Trane recommends locating the controller:

- Near the controlled equipment to reduce wiring
- Where service personnel have easy access
- Where it is easy to see the operator display
- Where public access is restricted to minimize the possibility of tampering or vandalism

NOTICE

Avoid Equipment Damage!
Install the controller in a location that is not in direct sunlight. Failure to do so may cause the controller to overheat.

3

Operating Environment

Ensure that the operating environment conforms to the specification listed in Table 2.

Table 2. Specifications

Temperature:	From 32°F to 122°F (0°C to 50°C)
Humidity:	10–90% non-condensing
Power Requirements:	120 Vac or 230 Vac, 1 A maximum, 1 phase, 50 or 60 Hz
Weight:	Mounting surface must be able to support 60 lb. (28 kg)
Dimensions:	16 ½ in. × 14 ¾ in. × 5 ½ in. (418 mm × 373 mm × 140 mm)
Altitude:	6,500 ft (2,000 m)
Installation:	Category 3
Pollution:	Degree 2

4

Minimum Clearances and Dimensions

Ensure that the selected location provides ample space for the minimum clearance and enclosure dimensions as shown in Figure 1.

Figure 1. Minimum clearances and enclosure dimensions

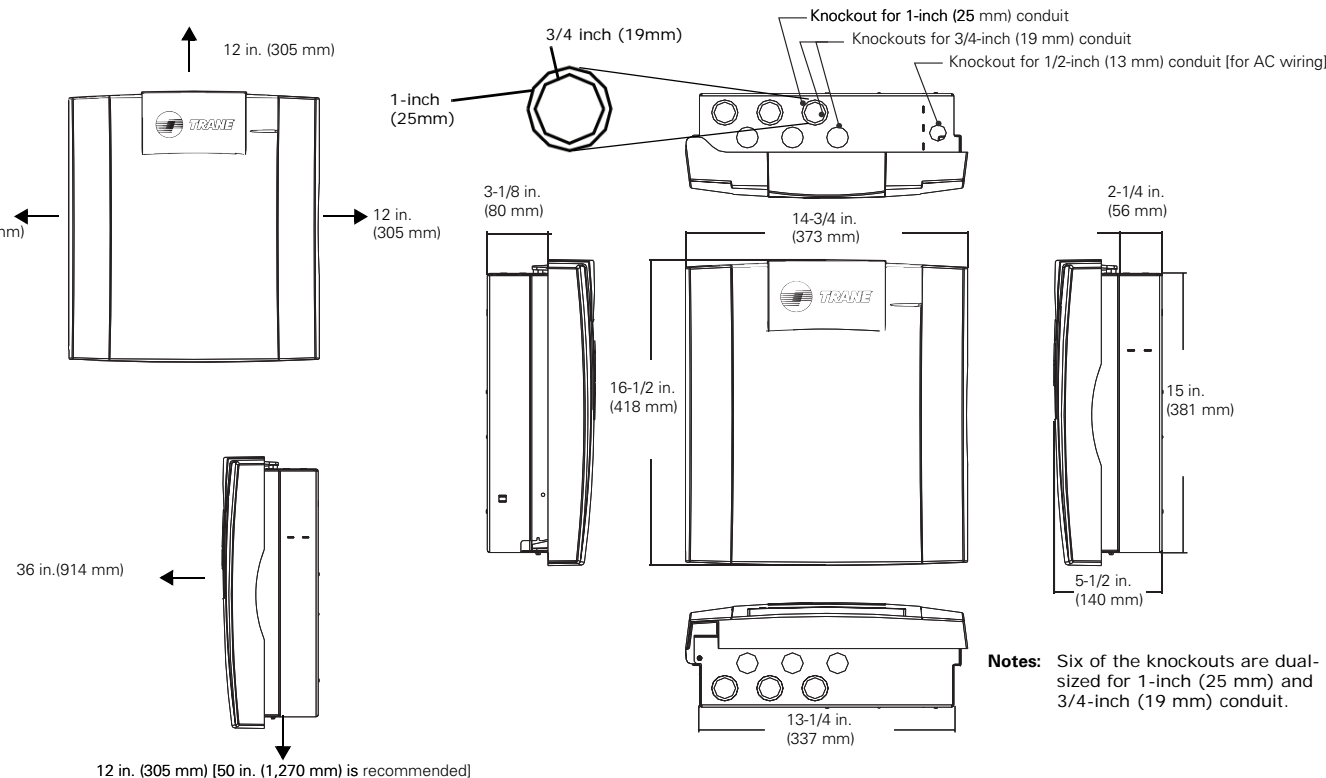

Notes: Six of the knockouts are dual-sized for 1-inch (25 mm) and 3/4-inch (19 mm) conduit.

5

Mounting the Enclosure

Note: The back of the enclosure ships with the termination board installed inside (the enclosure door is shipped separately). If the door is already attached to the enclosure back, remove it.

To mount the enclosure:

1. Use the enclosure as a template and mark the location of the four mounting holes on the mounting surface.
2. Set aside the enclosure and drill holes for the screws at the marked locations.

Note: Drill holes for #10 (5 mm) screws or #10 wall anchors. Use wall anchors if the mounting surface is dry wall or masonry.

3. Insert wall anchors if needed.
4. Secure the enclosure to the mounting surface with the enclosed #10 (5 mm) screws.

Figure 2. Enclosure mounting holes

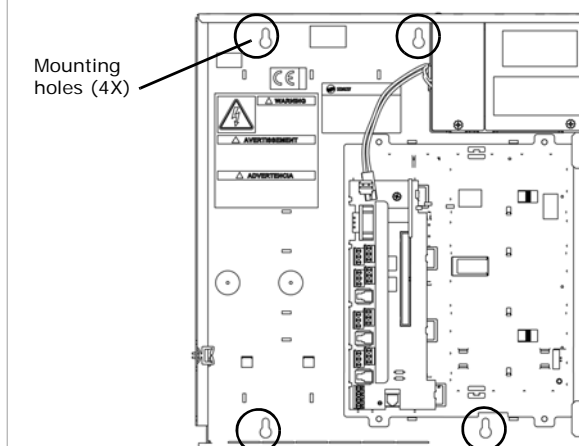

6

Wiring High-voltage AC Power

WARNING

Hazardous Voltage!
Disconnect all electrical power, including remote disconnects, before servicing. Follow proper lockout/tagout procedures to ensure the power cannot be inadvertently energized. Failure to disconnect power before servicing could result in death or serious injury.

NOTICE

Use Copper Conductors Only!
Unit terminals are designed to accept copper conductors only. Other conductors may cause equipment damage.

Important: Ensure you are using the correct controller model for 120 Vac or 230 Vac. Refer to Table 1.

To ensure proper operation of the controller, install the power supply circuit in accordance with the following guidelines:

- The controller must receive power from a dedicated power circuit. Failure to comply may cause control malfunctions.
- A disconnect switch for the dedicated power circuit must be near the controller, within easy reach of the operator, and marked as the disconnecting device for the controller.
- High-voltage power-wire conduits or wire bundles must not contain input/output wires. Failure to comply may cause the controller to malfunction due to electrical noise.
- High-voltage power wiring must comply with the National Electrical Code™ (NEC) and applicable local electrical codes.
- High-voltage wiring requires three-wire 120/230 Vac service (line, neutral, ground).

Note: The transformer voltage utilization range is 98–132 Vac (120 Vac nominal) or 196–264 Vac (230 Vac nominal). The panel automatically detects whether the current is 50 or 60 cycle.

7 Connecting High-voltage Power Wires

To connect high-voltage power wires:

1. Lock open the supply-power disconnect switch.
2. At the top-right corner of the enclosure, remove the knockout for ½-inch (13 mm) conduit.
3. Open or remove the enclosure door if it is already installed.
4. Inside of the enclosure at the top-right corner, remove the high-voltage area cover plate.
5. Feed the high-voltage power wire into the enclosure.
6. Connect the line wire to the **L terminal** (Figure 3).

Figure 3. AC wiring

7. Connect the neutral wire to the **N terminal**.
8. Connect the green ground wire to the chassis ground screw. The ground wire should be continuous back to the circuit breaker panel.

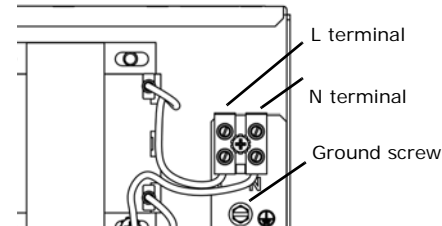

WARNING

Hazardous Voltage!
The cover plate must be in place when the controller is operating. Failure to replace the cover plate could result in death or serious injury.

1. Replace the cover plate.
2. On a label, record the location of the circuit breaker panel and the electrical circuit. Attach the label to the cover plate.

8 UCM and Binary Input Wiring

For detailed information about wiring UCM or binary input, refer to the *Tracer Communications Bridge - Comm 3/4 to Tracer SC Setup and Configuration Guide* (BAS-SVX64).

Installing the Main Circuit Board

The controller does not ship with the top plastic frame installed. The board can be kept in the office and programmed while the enclosure is mounted and wired. After programming has been completed, connect the circuit board to the termination board. To begin, verify that the 24 Vac power cable is not connected to the termination board and then install the main circuit board as shown in figures below.

Figure 4. Installing the main circuit boards

1. Connect the 60-pin cable (C) to the 60-pin cable ejector slot (D) by pressing down firmly on the cable until the ejector tabs collapse and snap over the ends of the cable (refer to the bottom left inset above).
2. Align the snaps on the top frame (E) with the mounting locks on the bottom frame and then push the two frames together in the direction indicated by the arrows.

Note: You will hear a click when the frames connect.

3. Connect the 24 Vac power cable to the termination board (F). The seven-segment LED will light (G).
4. Connect the Ethernet cable to the Ethernet connector (H) on the circuit board.

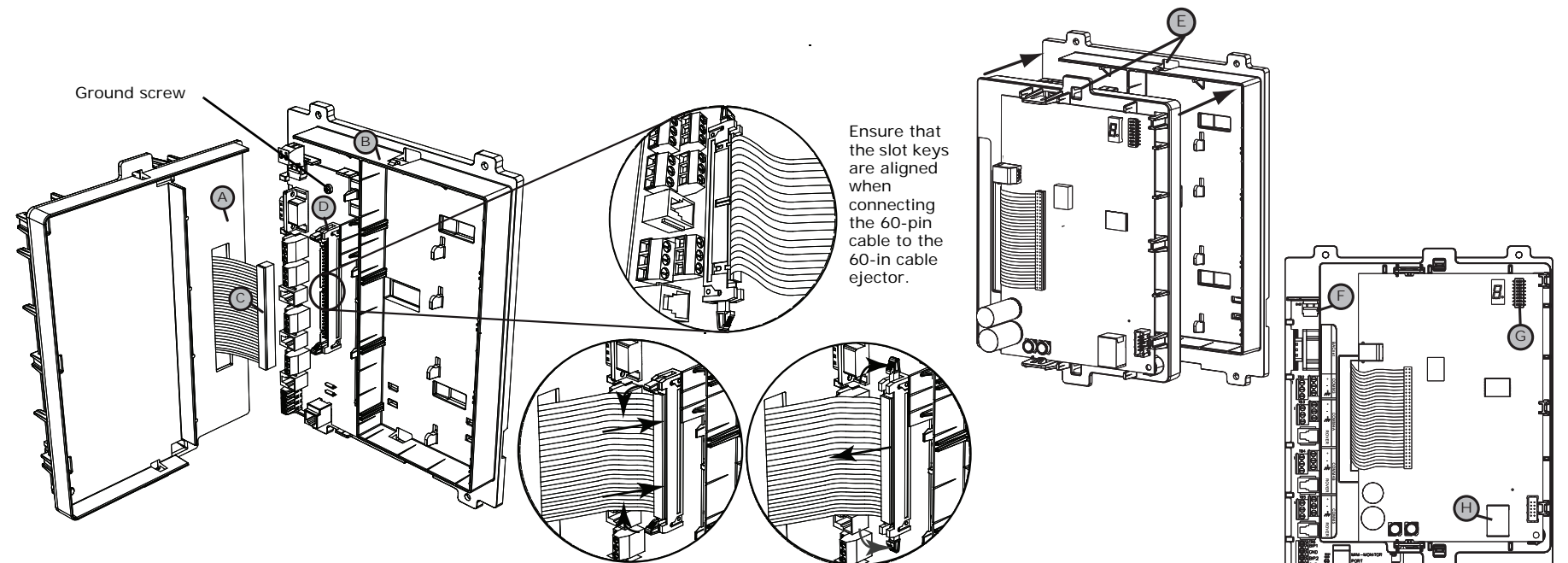

Important: The 60-pin cable ejector is designed to eject the 60-pin cable when disconnecting. (Refer to the lower right inset above.)

9 Installing the Enclosure Door

Note: Unpack the door and check for missing or damaged parts and any cracks in the plastic.

To install the enclosure door:

1. Hold the door at a 90° angle from the enclosure as shown in the figure.
2. Align the hinge pegs on the door with the hinge holes on the enclosure.
3. Gently lower the door until it rests securely in the hinge holes.

Verify that the door swings freely on the hinges and that the magnetic latches hold the door securely when it is closed.

Figure 5. Aligning the hinge pegs with the hinge holes

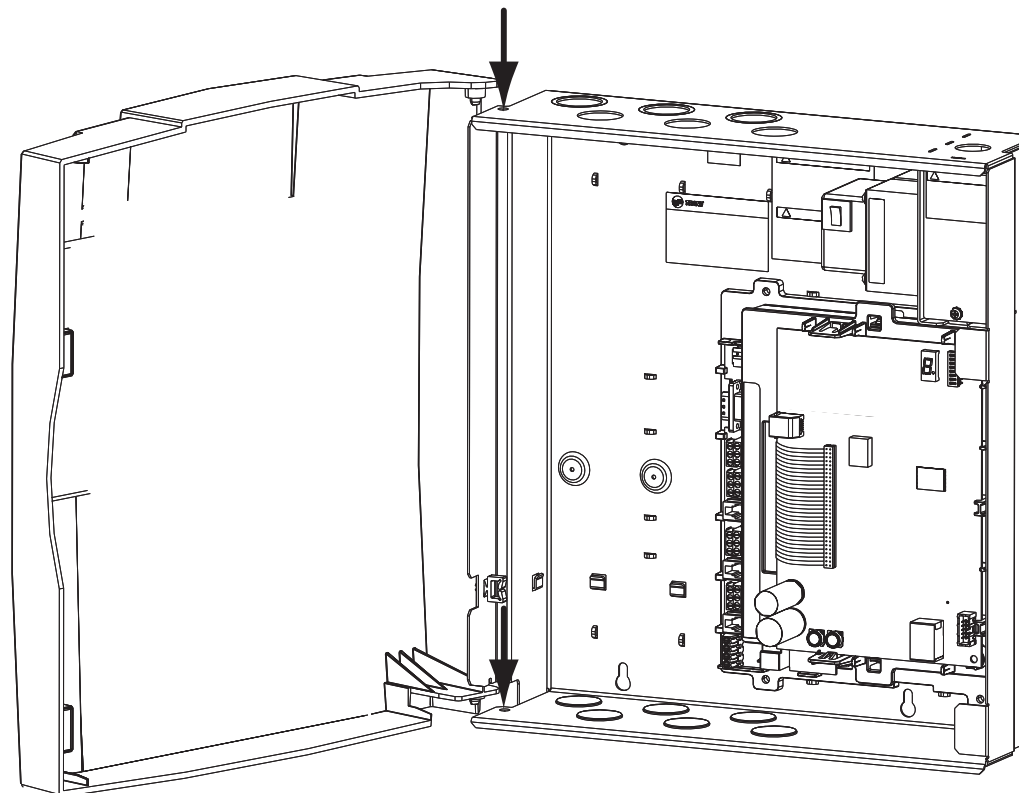

10 Agency Listings and Compliance

The European Union (EU) Declaration of Conformity is available from your local Trane® office.

Trane - by Trane Technologies (NYSE: TT), a global climate innovator - creates comfortable, energy efficient indoor environments for commercial and residential applications. For more information, please visit trane.com or tranetechnologies.com.

Trane has a policy of continuous product and product data improvement and reserves the right to change design and specifications without notice. We are committed to using environmentally conscious print practices.