

Tracer® SC+ Controller for Tracer Concierge® System Installations

Order Numbers:
 BMTCO15ABC000000
 BMTCO30ABC000000

Packaged Contents

- One (1) Concierge Controller module
- Two (2) 4-position terminal block plugs
- Six (6) 3-position terminal block plugs
- One (1) DC power supply
- One (1) Label with 7 segment display codes
- One (1) Installation sheet

SAFETY WARNING

Only qualified personnel should install and service the equipment. The installation, starting up, and servicing of heating, ventilating, and air-conditioning equipment can be hazardous and requires specific knowledge and training. Improperly installed, adjusted or altered equipment by an unqualified person could result in death or serious injury. When working on the equipment, observe all precautions in the literature and on the tags, stickers, and labels that are attached to the equipment.

September 2021

BAS-SVN139D-EN

© 2021 Trane



1 Warnings, Cautions, and Notices

Read this manual thoroughly before operating or servicing this unit. Safety advisories appear throughout this manual as required. Your personal safety and the proper operation of this machine depend upon the strict observance of these precautions.

The three types of advisories are defined as follows:

- WARNING** Indicates a potentially hazardous situation which, if not avoided, could result in death or serious injury.
- CAUTION** Indicates a potentially hazardous situation which, if not avoided, could result in minor or moderate injury. It could also be used to alert against unsafe equipment or property-damage only accidents.
- NOTICE** Indicates a situation that could result in equipment or property-damage only accidents.

Important Environmental Concerns

Scientific research has shown that certain man-made chemicals can affect the earth's naturally occurring stratospheric ozone layer when released to the atmosphere. In particular, several of the identified chemicals that may affect the ozone layer are refrigerants that contain Chlorine, Fluorine and Carbon (CFCs) and those containing Hydrogen, Chlorine, Fluorine and Carbon (HCFCs). Not all refrigerants containing these compounds have the same potential impact to the environment. Trane advocates the responsible handling of all refrigerants-including industry replacements for CFCs such as HCFCs and HFCs.

Important Responsible Refrigerant Practices

Trane believes that responsible refrigerant practices are important to the environment, our customers, and the air conditioning industry. All technicians who handle refrigerants must be certified according to local rules. For the USA, the Federal Clean Air Act (Section 608) sets forth the requirements for handling, reclaiming, recovering and recycling of certain refrigerants and the equipment that is used in these service procedures. In addition, some states or municipalities may have additional requirements that must also be adhered to for responsible management of refrigerants. Know the applicable laws and follow them.

2 WARNING

Proper Field Wiring and Grounding Required!
 Failure to follow code could result in death or serious injury. All field wiring MUST be performed by qualified personnel. Improperly installed and grounded field wiring poses FIRE and ELECTROCUTION hazards. To avoid these hazards, you MUST follow requirements for field wiring installation and grounding as described in NEC and your local/state/national electrical codes.

WARNING

Personal Protective Equipment (PPE) Required!
 Failure to wear proper PPE for the job being undertaken could result in death or serious injury. Technicians, in order to protect themselves from potential electrical, mechanical, and chemical hazards, MUST follow precautions in this manual and on the tags, stickers, and labels, as well as the instructions below:

- Before installing/servicing this unit, technicians MUST put on all PPE required for the work being undertaken (Examples; cut resistant gloves/sleeves, butyl gloves, safety glasses, hard hat/bump cap, fall protection, electrical PPE and arc flash clothing). ALWAYS refer to appropriate Safety Data Sheets (SDS) and OSHA guidelines for proper PPE.
- When working with or around hazardous chemicals, ALWAYS refer to the appropriate SDS and OSHA/GHS (Global Harmonized System of Classification and Labeling of Chemicals) guidelines for information on allowable personal exposure levels, proper respiratory protection and handling instructions.

If there is a risk of energized electrical contact, arc, or flash, technicians MUST put on all PPE in accordance with OSHA, NFPA 70E, or other country-specific requirements for arc flash protection, PRIOR to servicing the unit. NEVER PERFORM ANY SWITCHING, DISCONNECTING, OR VOLTAGE TESTING WITHOUT PROPER ELECTRICAL PPE AND ARC FLASH CLOTHING. ENSURE ELECTRICAL METERS AND EQUIPMENT ARE PROPERLY RATED FOR INTENDED VOLTAGE.

3 WARNING

Follow EHS Policies!
 Failure to follow instructions below could result in death or serious injury.

- All Trane personnel must follow the company's Environmental, Health and Safety (EHS) policies when performing work such as hot work, electrical, fall protection, lockout/tagout, refrigerant handling, etc. Where local regulations are more stringent than these policies, those regulations supersede these policies.
- Non-Trane personnel should always follow local regulations.

NOTICE

Risk of Battery Exploding!
 Failure to follow instructions below could cause the battery to explode resulting in equipment damage. Do NOT use a non-compatible battery with the controller! It is critical that a compatible battery be used.

Risque d'Explosion de la Pile!
 Le non-respect des instructions qui suivent pourrait provoquer l'explosion de la pile et des dégâts à l'équipement. Ne PAS utiliser de pile non compatible avec le contrôleur! Il est très important qu'une pile compatible soit utilisée.

Copyright

This document and the information in it are the property of Trane, and may not be used or reproduced in whole or in part without written permission. Trane reserves the right to revise this publication at any time, and to make changes to its content without obligation to notify any person of such revision or change.

Trademarks

All trademarks referenced in this document are the trademarks of their respective owners.

Required Tools

- 5/16 in. (8 mm) slotted screwdriver
- 1/8 in. (3 mm) slotted screwdriver

4 Specifications

Table 1. SC+ Controller Specifications

Power Requirements	
24 Vdc @ 0.4A; OR 24 Vac @ 30 VA. Class 2 power source only	
Storage	
Temperature:	-40°C to 70°C (-40°F to 158°F)
Relative humidity:	Between 5% to 95% (non-condensing)
Operating Environment	
Temperature:	-40°C to 50°C (-40°F to 122°F)
Humidity:	Between 10% to 90% (non-condensing)
Product weight	1 kg (2.2 lb.)
Altitude:	Maximum 2,000 m (6,500 ft.)
Installation:	Category 3
Pollution	Degree 2

Mounting the SC+ Controller

- The mounting location must meet the temperature and humidity specifications as outlined in Table 1.
- Do not mount on a flat surface, such as on a floor or on top of a table. Mount in an upright position with the front facing outward.

To mount the SC+ Controller:

1. Hook the top half of the SC+ Controller onto the DIN rail.
2. Gently push on the lower half of the SC+ Controller until the release clip snaps into place.

5 Figure 1. Mounting the SC+ Controller

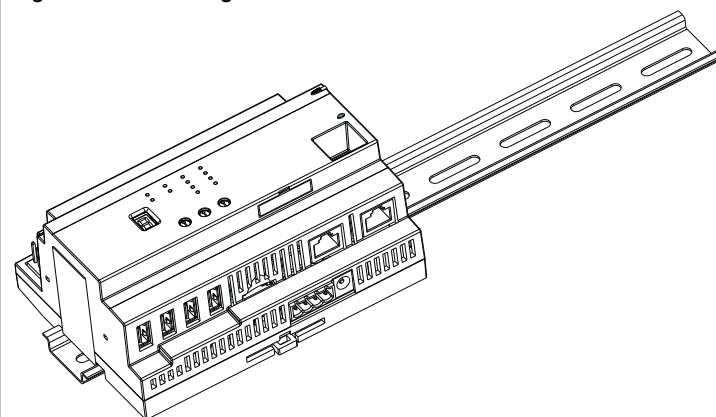

Removing or Repositioning the SC+ Controller

To remove or reposition the SC+ Controller:

1. Insert a screwdriver into the slotted release clip and gently pry upward on the clip with the screwdriver, **OR;** If the screwdriver fits the slot size, insert the screwdriver into the slotted release clip and rotate it to the left or right to release tension on the clip.
2. While holding tension on the slotted release clip, lift the SC+ Controller upward to remove or reposition.
3. If repositioning, push on the SC+ Controller until the slotted release clip snaps back into place.

6 Figure 2. Removing the SC+ Controller

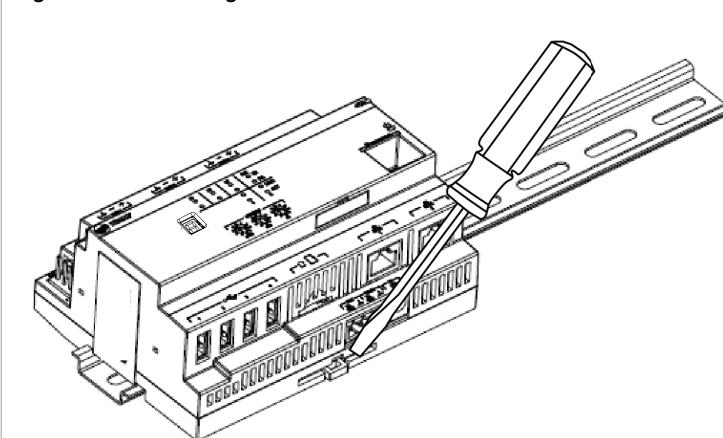

7 Wiring and Applying Power

The SC+ Controller can be powered one of two ways:

- External 24 Vdc Power adapter
- Transformer (wire 24 Vac to the 4-position terminal block)

External 24 Vdc Power Adapter (Preferred Method)

1. Connect the power adapter to a standard power receptacle, such as a wall outlet.
2. Connect the barrel end of the power supply to the 24 Vdc input of the SC+ Controller.
3. Ensure that the SC+ Controller is properly grounded.

Important: This device must be grounded for proper operation! The factory-supplied ground wire must be connected from any chassis ground connection on the device to an appropriate earth ground.

Note: The SC+ Controller is NOT grounded through the DIN rail connection.

4. Apply power to the SC+ Controller by pressing the power button. All status LEDs illuminate and the following sequence flashes on the 7-segment display: 8, 7, 5, 4, L, dancing dash pattern. The dancing dashes continue while the SC+ Controller is operating normally.

Transformer

This procedure involves wiring 24 Vac to the 4-position terminal block on the SC+ Controller.

- Using the provided 4-position terminal block, wire the 24 Vac input connection of the SC+ Controller to a dedicated 24 Vac, Class 2 transformer.
- Ensure that the SC+ Controller is properly grounded.

Important: This device must be grounded for proper operation! The factory-supplied ground wire must be connected from any chassis ground connection on the device to an appropriate earth ground. The chassis ground connection can be the 24 Vac transformer input at the device, or any other chassis ground connection on the device.

Note: The Tracer SC+ Controller is NOT grounded through the DIN rail connection.

Apply power to the SC+ Controller by pressing the power button. All status LEDs illuminate and the following sequence flashes on the 7-segment display: 8, 7, 5, 4, L, dancing dash pattern. The dancing dashes continue while the SC+ Controller is operating normally.

Connect WCI to SC+ Controller

Connect the WCI to the SC+ Controller as shown in Figure 3.

Figure 3. WCI Connection

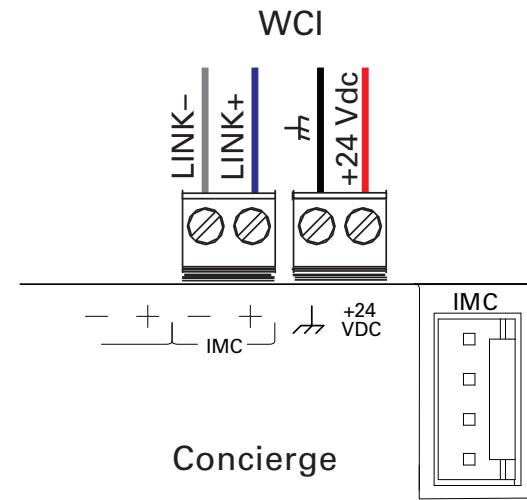

BACnet® MS/TP

This section describes best practices and procedures for wiring BACnet unit controllers to a SC+ Controller.

BACnet MS/TP Link Wiring

BACnet MS/TP link wiring must be field-supplied and installed in compliance with the National Electric Code (NEC) and local codes.

BACnet Configuration Requirements

Follow these configuration requirements:

- BACnet wiring must use daisy-chain configuration. Maximum length is 4,000 ft (1219 m).
- BACnet links are polarity sensitive; consistent wiring polarity must be maintained between devices.
- Limit each link to 30 controllers or 60 total controllers per SC+ Controller.

BACnet Wiring Best Practices

The following wiring practices are recommended:

- Use 18 AWG, (24 pF/ft. max.), communication wire (Trane purple wire).
- Strip no more than 2 in. (5 cm) of the outer conductor of shielded wire.
- Avoid sharing 24 Vac power between unit controllers.
- Ensure that 24 Vac power supplies are consistently grounded. If grounds are not maintained, intermittent or failed communication could result.
- Connect the shield portion of the communication wire at the first unit controller in the link.
- Use a Tracer BACnet terminator at each end of the link.

BACnet Wiring Procedure

Follow these steps to connect communication wiring:

- Attach the communication link wiring to the SC+Controller at Link 1 or Link 2.

Note: It is not necessary to place the SC+ Controller at the end of the of the communication link.

- Attach the wiring from the first unit controller to the first set of communication terminals on the next unit controller.

Note: Some unit controllers have only one set of communication terminals. In that case, attach the wiring to the same set of terminals.

- Wire and tape shields together at each unit controller between the SC+ Controller and the BACnet terminator.
- Repeat steps 1 through 3 for each unit controller on the link.

Note: For more information about the specific unit controller you are wiring, see the installation guide for the specific controller.

Trane BACnet Termination for BACnet Links

For correct termination placement, follow these guidelines:

- All BACnet links must be properly terminated. Use a Tracer BACnet terminator at each end of the link.
- Tape back the shield at each of the BACnet terminators.

During installation, compile a set of as-built drawings or a map of the communication wire layout. Sketches of the communication layout should feature the BACnet terminators.

Figure 4. Daisy-chain configuration for BACnet wiring

