



Installation Instructions

Large Enclosure for Tracer® DIN-mounted Controllers (120VAC)

Ordering Numbers: X13651552-01 (solid door)
X13651553-01 (display-capable door)

Packaged Contents

- One (1) enclosure
- Six (6) #10 (5mm) screws with anchors
- Five (5) M4 screws

Model Numbers

Before installing the controller, verify the correct model for local power requirements. The model number is on the shipping label or on the product label inside the enclosure.

X39641192-01

SAFETY WARNING

Only qualified personnel should install and service the equipment. The installation, starting up, and servicing of heating, ventilating, and air-conditioning equipment can be hazardous and requires specific knowledge and training. Improperly installed, adjusted or altered equipment by an unqualified person could result in death or serious injury. When working on the equipment, observe all precautions in the literature and on the tags, stickers, and labels that are attached to the equipment.

June 2020

BAS-SVN087J-EN

© 2020 Trane



1

Replacement Parts

- Display-capable door (part no. DOR03989)
- Solid door (part no. DOR03988)
- 120 VAC transformer (part no. TRR02421)
- Entire unit w/o cover, 120 VAC (part no. TRR02423)
- 24 VAC power cables (2) (part no. CAB01401)

Optional Part

Lock and key (part no. KEY01074) (Optional part available through Trane Parts Centers)

Warnings, Cautions, and Notices

Read this manual thoroughly before operating or servicing this unit. Safety advisories appear throughout this manual as required. Your personal safety and the proper operation of this machine depend upon the strict observance of these precautions.

The three types of advisories are defined as follows:

WARNING Indicates a potentially hazardous situation which, if not avoided, could result in death or serious injury.

CAUTION Indicates a potentially hazardous situation which, if not avoided, could result in minor or moderate injury. It could also be used to alert against unsafe equipment or property-damage only accidents.

NOTICE Indicates a situation that could result in equipment or property-damage only accidents.

WARNING

Proper Field Wiring and Grounding Required!
Failure to follow code could result in death or serious injury. All field wiring MUST be performed by qualified personnel. Improperly installed and grounded field wiring poses FIRE and ELECTROCUTION hazards. To avoid these hazards, you MUST follow requirements for field wiring installation and grounding as described in NEC and your local/state electrical codes.

2

WARNING

Personal Protective Equipment Required!
Installing/servicing this unit could result in exposure to electrical, mechanical and chemical hazards. Before installing/servicing this unit, technicians MUST put on all Personal Protective Equipment (PPE) recommended for the work being undertaken. ALWAYS refer to appropriate SDS sheets and OSHA guidelines for proper PPE. When working with or around hazardous chemicals, ALWAYS refer to the appropriate SDS sheets and OSHA guidelines for information on allowable personal exposure levels, proper respiratory protection and handling recommendations. If there is a risk of arc or flash, technicians MUST put on all necessary Personal Protective Equipment (PPE) in accordance with NFPA70E for arc/flash protection PRIOR to servicing the unit. Failure to follow recommendations could result in death or serious injury.

Specifications and Dimensions

Operating Environment Specifications

Make sure that the operating environment conforms to the specifications listed in Table 1.

Table 1. Specifications

Temperature	From 0°C (32°F) to see Table 2.
Humidity	Maximum relative humidity 80% for temperatures up to 31°C decreasing linearly to 50% relative humidity at 40°C
Power requirements	120 VAC nominal + 10% maximum fluctuations, 6A maximum, 1 phase, 60 Hz
Weight	Mounting surface must be able to support 55 kg (120 lb).
Dimensions	62 cm x 73.3 cm x 10.7 cm (24.5 in. x 28.9 in. x 4.2 in.)
Installation	U.L. 840: Category 3
Pollution	U.L. 840: Degree 2
Environment	Indoor use - type 1
Altitude	Up to 2,000m (6,561 feet)

3

The power output of the panel is de-rated at higher ambient temperatures to account for the heat rise in the panel. Table 2 shows the ratings.

Table 2. Power output (per transformer)

VA at 24 VAC	Temperature Range C°/F°
85	up to 35°C (95°F)
65	up to 45°C (113°F)
45	up to 50°C (122°F)

DIN Unit Widths

The following table provides DIN unit width measurements for Trane devices. The enclosure DIN rail is approximately 33 DIN unit widths.

Table 3. DIN unit width measurements

Device	Device Width (mm/in)	DIN Unit Widths (1 unit = 18 mm)
Tracer SC system controller	143.6 mm/5.6 in	8
Tracer UC400 controller	143.6 mm/5.6 in	8
Tracer UC600 controller	215.5 mm/8.50 in.	12
Tracer UC800 controller	71.6 mm/2.8 in	4
Tracer XM30 expansion module	53.6 mm/2.1 in	3
Tracer XM32 expansion module	71.6 mm/2.8 in	4
Tracer XM70 expansion module	215.5 mm/8.50 in.	12
PM014 power supply module	107.6 mm/4.2 in	6
Tracer BACnet terminator	35.6 mm/1.4 in	2

4

Clearances and Dimensions

Minimum clearances and internal enclosure dimensions are shown in Figure 1. Ensure that the selected mounting location provides adequate space for the minimum clearances. For external enclosure dimensions, see Figure 2.

Figure 1. Minimum Clearances and Internal Dimensions

Internal view of enclosure

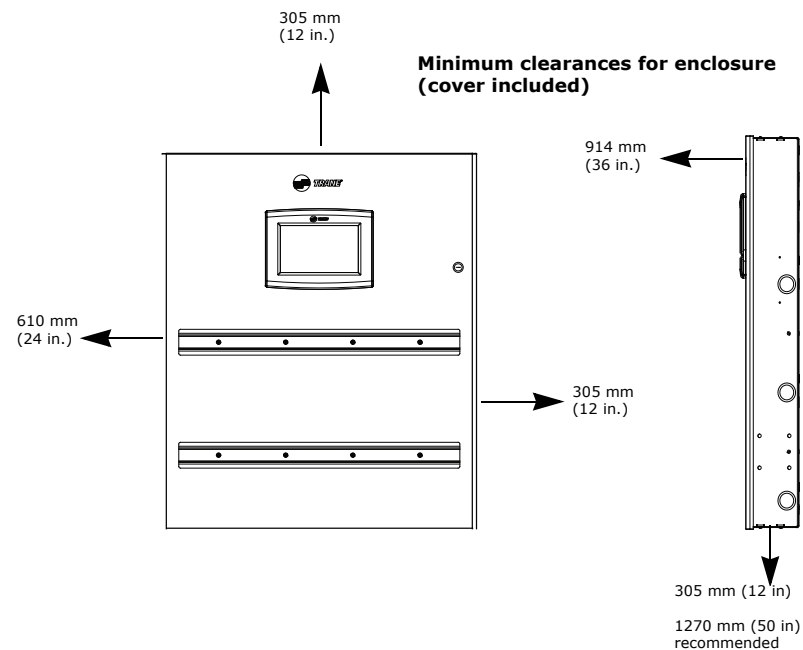
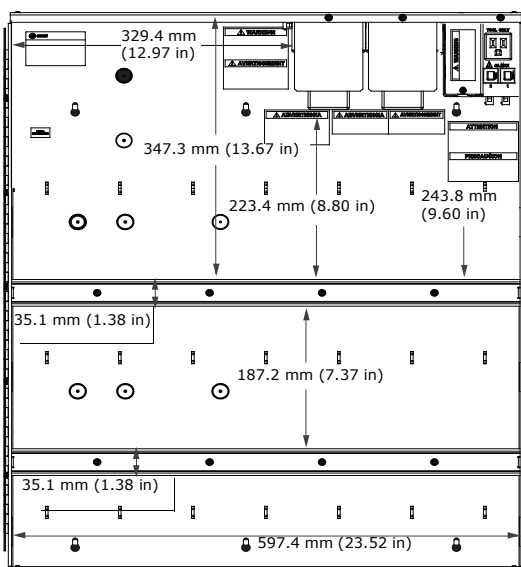

5

Figure 2. External dimensions

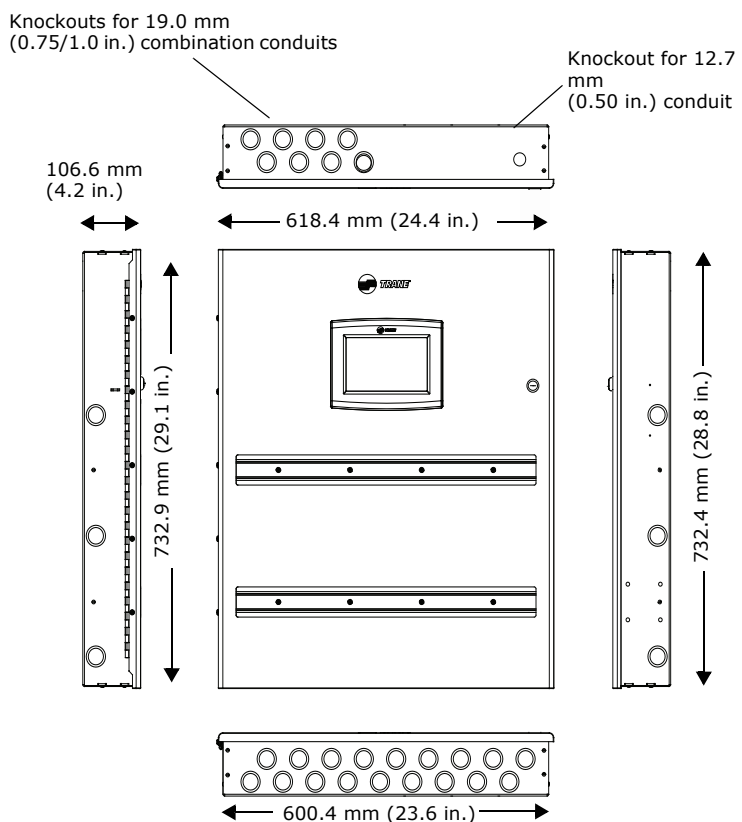

6

Mounting and Wiring

Location

Ensure that the location meets the operating environment requirements and clearances described in previous sections. The controller must be installed indoors. Trane recommends mounting the controller:

- Near the controlled equipment to reduce wiring.
- Where service personnel have easy access.
- Where public access is restricted to minimize the possibility of tampering or vandalism.

Mounting Instructions

To mount the enclosure:

1. Use the enclosure as a template and mark the location of the six mounting holes on the mounting surface.
2. Set aside the enclosure and drill holes for the screws at the marked locations.

Note: Drill holes for #10 screws and #10 wall anchors. Use wall anchors if the mounting surface is dry wall or masonry.

3. Secure the enclosure to the mounting surface with the enclosed #10 screws and #10 wall anchors.

7

Wiring High-voltage AC Power

Read all warnings and cautions prior to wiring high-voltage AC power.

⚠ WARNING

Hazardous Voltage!

Disconnect all electrical power, including remote disconnects, before servicing. Follow proper lockout/tagout procedures to ensure the power cannot be inadvertently energized. Failure to disconnect power before servicing could result in death or serious injury.

⚠ WARNING

Proper Field Wiring and Grounding Required!

Failure to follow code could result in death or serious injury. All field wiring MUST be performed by qualified personnel. Improperly installed and grounded field wiring poses FIRE and ELECTROCUTION hazards. To avoid these hazards, you MUST follow requirements for field wiring installation and grounding as described in NEC and your local/state electrical codes.

NOTICE

Use copper conductors only!

Unit terminals are designed to accept copper conductors only. Other conductors could cause equipment damage.

To ensure proper operation of the controller, install the power supply circuit in accordance with the following guidelines:

- The panel must receive power from a dedicated power circuit. Failure to comply could cause panel malfunctions.
- A disconnect switch for the dedicated power circuit must be near the panel, within easy reach of the operator, and marked as the disconnecting device for the panel.
- 24 VAC or higher power-wire conduits or wire bundles must not contain input or output wires. Failure to comply could cause the controller to malfunction due to electrical noise.

8

- Power wiring must comply with the National Electrical Code™ (NEC) and applicable electrical codes.
- 120 VAC wiring requires three-wire service (line, neutral, ground).

Note: The transformer voltage utilization range is 98–132 VAC (120 VAC nominal).

To connect 120 VAC power wires:

1. Lock open the supply-power disconnect switch.
2. At the top-right corner of the enclosure, remove the knockout for 0.75 inch (19 mm) conduit.
3. Open or remove the enclosure door if has already been installed.
4. Inside of the enclosure at the top-right corner, remove the line voltage area cover plate.
5. Feed the 120 VAC power wire into the enclosure.
6. Connect the line wire to the 'L' terminal as shown in Figure 3. Connect the neutral wire to the 'N' terminal as shown in Figure 3.
7. Connect the green ground wire to the chassis ground screw as shown in Figure 3.

Note: The ground wire should be continuous back to the circuit breaker panel.

⚠ WARNING

Hazardous Voltage!

The cover plate must be in place when the controller is operating. Failure to replace the cover plate could result in death or serious injury

8. Replace the cover plate.
9. On a field-supplied label, record the location of the circuit breaker panel and the electrical circuit. Attach the label to the cover plate.

9

Figure 3. AC wiring for 120 VAC

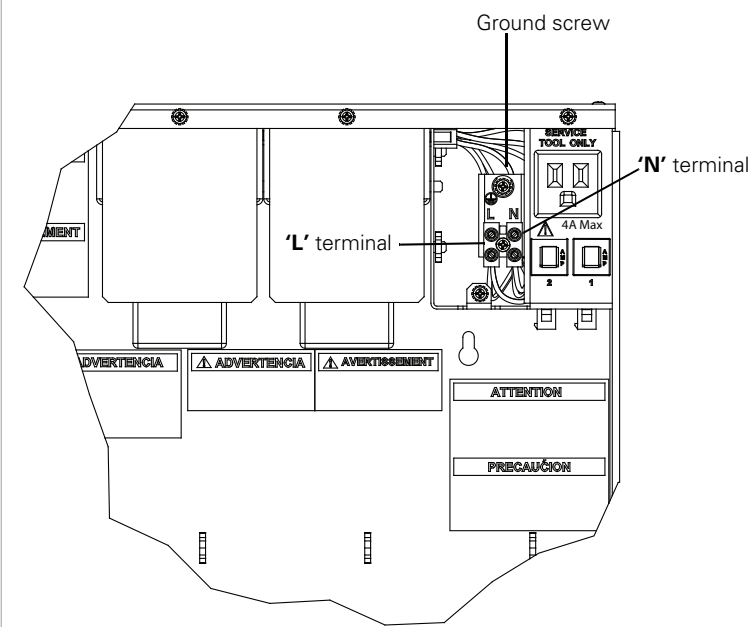

10

Installing the Enclosure Door

To install the enclosure door:

1. Remove packaging from the door and locate the provided hardware (five M4 screws).
2. Position the door on the front of the enclosure in its approximate position, with the lock on the right-hand side.
3. Lock the enclosure door to assist in holding the door on the enclosure.
4. Align the screw holes with the threaded hardware on the door hinge so that the screws can be inserted through the door.
5. Insert one screw into a screw hole on the upper half of the door; finger tighten only.
6. Insert the remaining four screws in the screw holes; finger tighten only.
7. While applying slight upward pressure on the door, use a screwdriver to securely tighten one screw on the upper portion of the door and one screw on the lower portion of the door.
8. Unlock the door and ensure that it opens and closes freely.
9. Securely tighten the remaining screws.

11

Figure 4. Installing the enclosure door

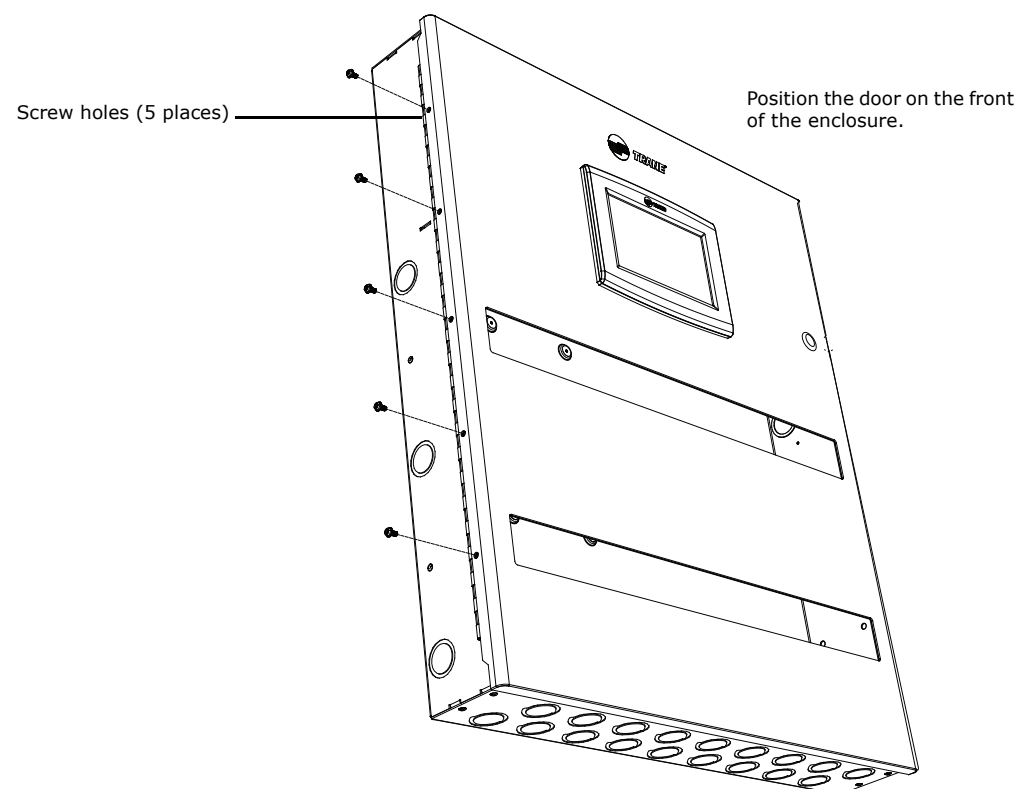

After tightening the screws, unlock door and verify that it opens and closes freely.

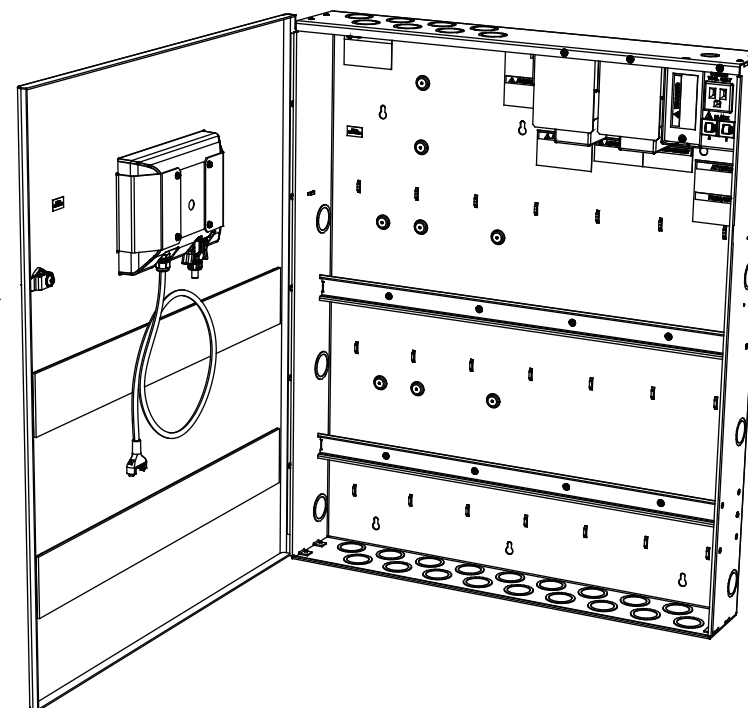

12

Agency Listings and Compliance

Manufacturer

Trane
4833 White Bear Prkwy
St. Paul, MN 55110
USA

United States compliance

- UL Listed — UL 916 Energy Management Accessory

Canada compliance

CUL Listed — CSA C22.2 No. 205

Trane - by Trane Technologies (NYSE: TT), a global climate innovator - creates comfortable, energy efficient indoor environments for commercial and residential applications. For more information, please visit trane.com or tranetechnologies.com.

Trane has a policy of continuous product and product data improvement and reserves the right to change design and specifications without notice. We are committed to using environmentally conscious print practices.