



Installation Instructions

Air-Fi® Wireless Communications Interface (WCI)

Model Numbers:	Notes:
X13790901, X13790902, X13790903, X13790904, X13790941, X13790963, X13790964	A) Pollution Degree 2 B) Impulse Voltage: 330V (PELV (Class 2) Input and Output C) Software Class: Class A
X13790901, X13790902, X13790903, X13790904, and X13790963	These units are intended to be installed in accordance with the manufacturer's installation instructions, the National Electrical Code or Canadian Electrical Code, Part 1, and in a manner acceptable to the local authority having jurisdiction. Suitable for plenum use.

X39641361001

SAFETY WARNING

Only qualified personnel should install and service the equipment. The installation, starting up, and servicing of heating, ventilating, and air-conditioning equipment can be hazardous and requires specific knowledge and training. Improperly installed, adjusted or altered equipment by an unqualified person could result in death or serious injury. When working on the equipment, observe all precautions in the literature and on the tags, stickers, and labels that are attached to the equipment.

September 2024

BAS-SVN038F-EN

©2024 Trane



Warnings, Cautions, and Notices

Read this manual thoroughly before operating or servicing this unit. Safety advisories appear throughout this manual as required. Your personal safety and the proper operation of this machine depend upon the strict observance of these precautions.

The three types of advisories are defined as follows:

- WARNING** Indicates a potentially hazardous situation which, if not avoided, could result in death or serious injury.
- CAUTION** Indicates a potentially hazardous situation which, if not avoided, could result in minor or moderate injury. It could also be used to alert against unsafe practices.
- NOTICE** Indicates a situation that could result in equipment or property-damage only accidents.

Important Environmental Concerns

Scientific research has shown that certain man-made chemicals can affect the earth's naturally occurring stratospheric ozone layer when released to the atmosphere. In particular, several of the identified chemicals that may affect the ozone layer are refrigerants that contain Chlorine, Fluorine and Carbon (CFCs) and those containing Hydrogen, Chlorine, Fluorine and Carbon (HCFCs). Not all refrigerants containing these compounds have the same potential impact to the environment. Trane advocates the responsible handling of all refrigerants.

Important Responsible Refrigerant Practices

Trane believes that responsible refrigerant practices are important to the environment, our customers, and the air conditioning industry. All technicians who handle refrigerants must be certified according to local rules. For the USA, the Federal Clean Air Act (Section 608) sets forth the requirements for handling, reclaiming, recovering and recycling of certain refrigerants and the equipment that is used in these service procedures. In addition, some states or municipalities may have additional requirements that must also be adhered to for responsible management of refrigerants. Know the applicable laws and follow them.

WARNING

Proper Field Wiring and Grounding Required!
Failure to follow code could result in death or serious injury. All field wiring MUST be performed by qualified personnel. Improperly installed and grounded field wiring poses FIRE and ELECTROCUTION hazards. To avoid these hazards, you MUST follow requirements for field wiring installation and grounding as described in NEC and your local/state/national electrical codes.

WARNING

Personal Protective Equipment (PPE) Required!
Failure to wear proper PPE for the job being undertaken could result in death or serious injury. Technicians, in order to protect themselves from potential electrical, mechanical, and chemical hazards, MUST follow precautions in this manual and on the tags, stickers, and labels, as well as the instructions below:

- Before installing/servicing this unit, technicians MUST put on all PPE required for the work being undertaken (Examples: cut resistant gloves/sleeves, butyl gloves, safety glasses, hard hat/bump cap, fall protection, electrical PPE and arc flash clothing). ALWAYS refer to appropriate Safety Data Sheets (SDS) and OSHA guidelines for proper PPE.
- When working with or around hazardous chemicals, ALWAYS refer to the appropriate SDS and OSHA/GHS (Global Harmonized System of Classification and Labeling of Chemicals) guidelines for information on allowable personal exposure levels, proper respiratory protection and handling instructions.
- If there is a risk of energized electrical contact, arc, or flash, technicians MUST put on all PPE in accordance with OSHA, NFPA 70E, or other country-specific requirements for arc flash protection. PRIOR to servicing the unit. NEVER PERFORM ANY SWITCHING, DISCONNECTING, OR VOLTAGE TESTING WITHOUT PROPER ELECTRICAL PPE AND ARC FLASH CLOTHING. ENSURE ELECTRICAL METERS AND EQUIPMENT ARE PROPERLY RATED FOR INTENDED VOLTAGE.

WARNING

Follow EHS Policies!
Failure to follow instructions below could result in death or serious injury.

- All Trane personnel must follow the company's Environmental, Health and Safety (EHS) policies when performing work such as hot work, electrical, fall protection, lockout/tagout, refrigerant handling, etc. Where local regulations are more stringent than these policies, those regulations supersede these policies.
- Non-Trane personnel should always follow local regulations.

Copyright

This document and the information in it are the property of Trane, and may not be used or reproduced in whole or in part without written permission. Trane reserves the right to revise this publication at any time, and to make changes to its content without obligation to notify any person of such revision or change.

Trademarks

All trademarks referenced in this document are the trademarks of their respective owners.

Revision History

Updated the model numbers and notes information on the front cover.

Set Addresses

For detailed information and procedures, refer to the following documents:

- Air-Fi® Wireless System Installation, Operation, and Maintenance (BAS-SVX40*-EN)
- Air-Fi® Network Design Installation, Operation, and Maintenance (BAS-SVX55*-EN)

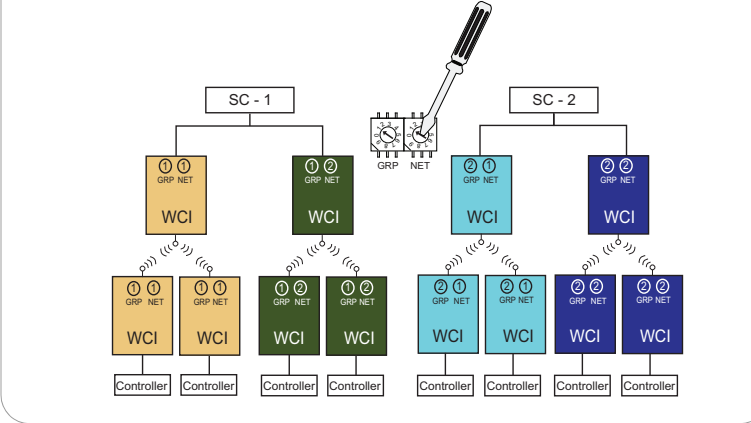

Connecting the Wiring Harness to the WCI

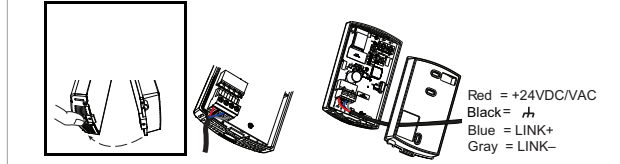

Power OFF Device

WARNING
Hazardous Voltage!
Failure to disconnect power before servicing could result in death or serious injury.
Disconnect all electric power, including remote disconnects before servicing. Follow proper lockout/tagout procedures to ensure the power can not be inadvertently energized. Verify that no power is present with a voltmeter.

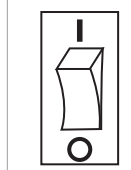

Connect WCI Wires to Controller

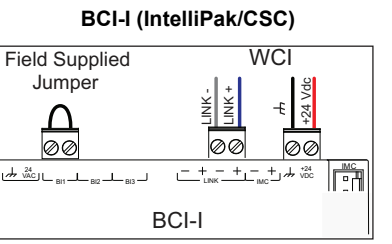
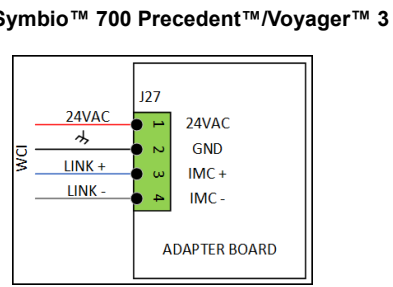
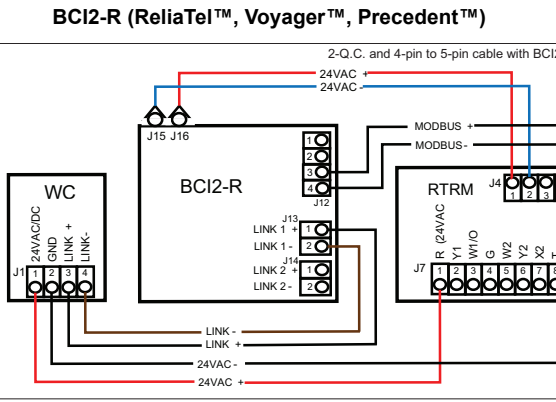
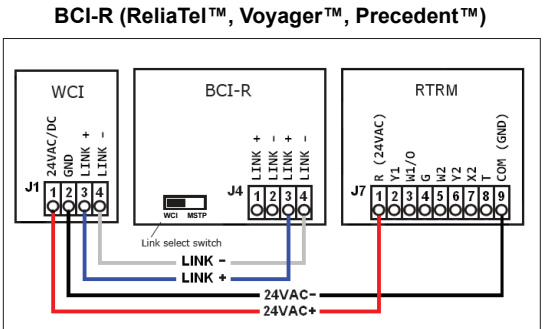
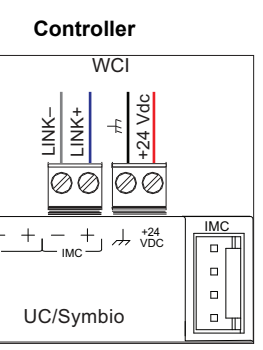
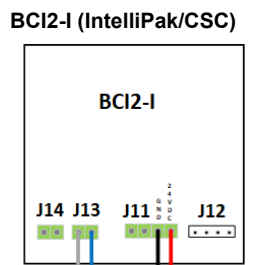
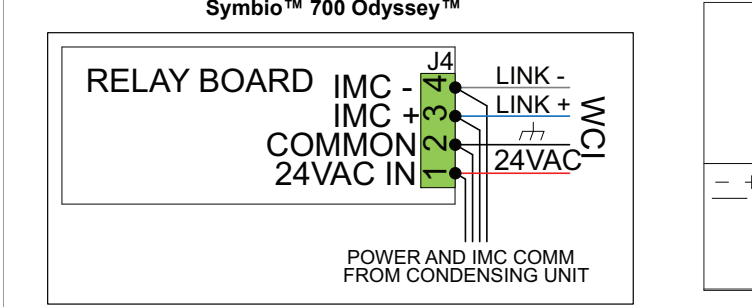
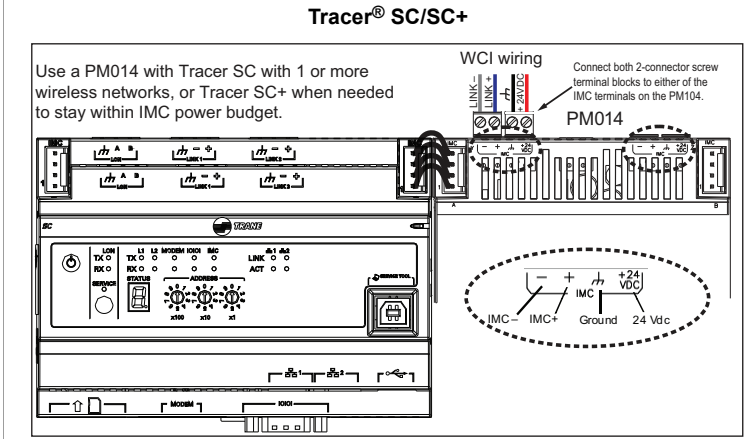

Tracer SC+/Symbio 800 when IMC power budget allows

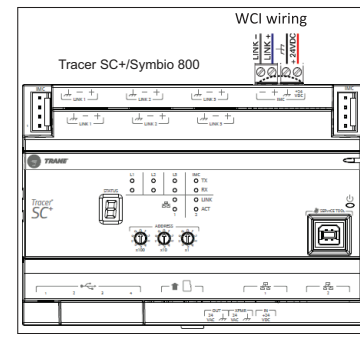

WCI as repeater

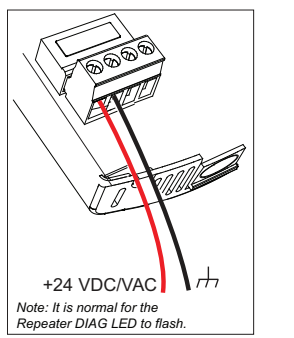

Power ON Device

Note: If all devices cannot be powered on at the same time, the best practice is to power them on in the following order:

1. All WCIs
2. All Tracer® SCs
3. All Controllers
4. All WCSs

Identifying the Network Coordinator (One per Network) and Initiating Network Formation

If a Tracer® SC/SC+ is present when the WCI is powered:

1. The WCI that is wired to Tracer SC/SC+ becomes network coordinator and network formation is initiated.
2. The network automatically opens and remains open for 60 minutes.
3. The LEDs illuminate on the network coordinator as shown. See Table 1 for details.

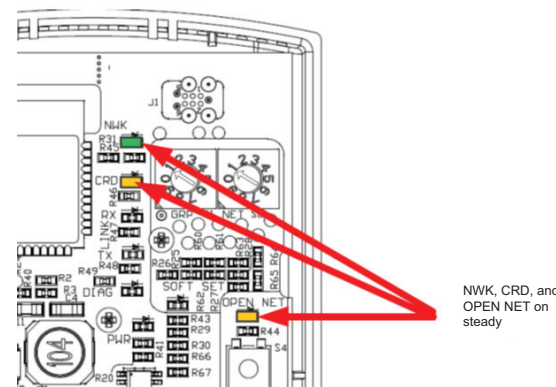

If no Tracer® SC/SC+ is present when the WCI is powered:

1. Identify a centrally located WCI to be the network coordinator.
2. Manually open the network by pressing the Start button for 5 seconds on the WCI that is to be network coordinator. The WCI becomes network coordinator and network formation is initiated.
3. Observe the LEDs on the network coordinator. See Table 1 for details.

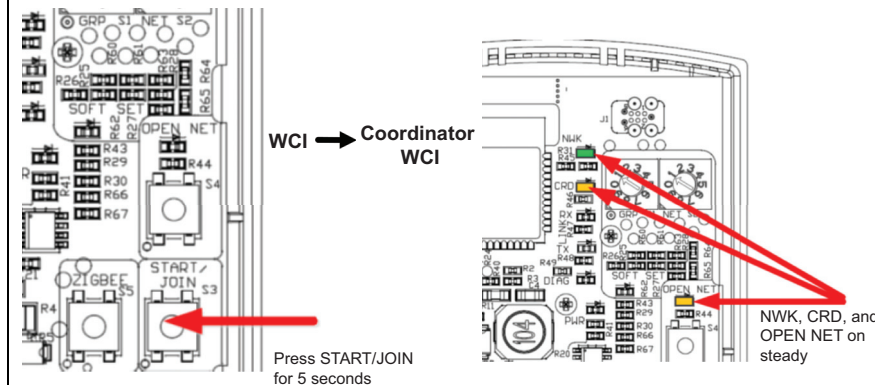

The Network Forms

The NWK LED illuminates on every WCI that joins the network.

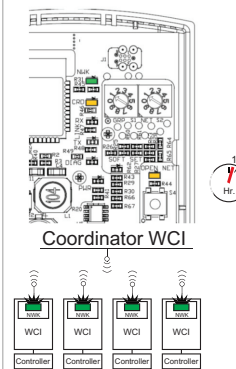

- Notes:**
- Network automatically stays open 1 hr. After each WCI joins, the 1 hr. timer starts over. If time expires, press OPEN NET to re-open the network.
 - The coordinator opens all WCIs in the network. A member WCI can only open itself for 10 minutes.

LED Identification and Interpretation

Table 1. LED identification and interpretation

LED	LED activity	Indicates
Network LED (green) NWK	On solid	WCI is a network member
	Flashes for 10 seconds every 2.5 minutes.	WCI is not a member of a network The WCI will join a network when the NWK LED is flashing. If there is an open network nearby with the same rotary settings and the WCI joins the network, the NWK LED turns on solid and then the OPEN LED turns on solid.
Coordinator LED (yellow) CRD	On solid	WCI is network coordinator
Open Net LED (yellow) OPEN NET	On solid	Network is open for joining
	Off	Network is closed for joining
Reception LED (yellow) RX LINK	Flashes ^(a)	Data received
	On ^(b)	Data received
	Off ^(c)	No data received

Table 1. LED identification and interpretation (continued)

LED	LED activity	Indicates
Transmission LED (green) TX LINK	Flashes ^(a)	Data transmitted
	On ^(b)	Data transmitted
	Off ^(c)	No data transmitted
Diagnostic LED (red) DIAG^(d)	Off	Normal operation
	Flashes (½ second on, ½ second off repeating)	Hardware failure or failed re-flash of a radio Corrective action: Replace WCI
	Triple flash pattern	Failed to join network. Occurs for 30 seconds after failing to join a network. Will continue this pattern until successful join. Corrective Action: Insure network is formed and open, then allow time for WCI to join on its own.
	Double flash pattern	<ul style="list-style-type: none"> • Normal for a repeater. • WCI lost IMC communication to the UC/BCI/Tracer® SC/SC+. Corrective action: Check IMC wiring, then cycle power to the controller/WCI to establish communication. <ul style="list-style-type: none"> • WCI was not configured correctly. (WCI did not get BACnet ID from UC/BCI/SC/SC+, and/or WCI did not get rotary address from the UC/BCI/SC/ SC+.) Corrective Action: Cycle power to the controller/WCI.
Power LED (green) PWR	On solid	WCI has power.
	Off	WCI does not have power. Corrective Action: Check WCI power wiring for 24v DC or AC.

(a) LED will flash steady (about 3 flashes per second) on WCI that was built prior to 2019.
 (b) LED will appear to be on steady for WCI built 2019 and after. Will appear dim and flicker occasionally according to how much data is passing.
 (c) LED is off for all WCI.
 (d) If more than one condition is present, the priority is in the order listed.

Firmware Requirements for Devices in an Air-Fi® Wireless Network

This table lists the minimum firmware levels required to allow devices to participate in an Air-Fi Wireless network.

Table 2. Minimum firmware levels required

Device	One or no WCSs	Multiple WCS-SB, or -SD and/or an RH sensor module (WCS-SH)	WCS-SO/SCO ₂	WCS-SB/R
Tracer® SC	v3.6.xxx	N/A	N/A	N/A
UC210	All versions	v2.00.xxx.mod	v3.0	v3.0
UC400	v6.00.xxx.mod	v8.00.xxx.mod	v9.0	v9.0
UC600	v4.00.xxx.mod	v5.00.xxx.mod	v6.0	v6.0
BCI-I	v25.00.xxx.mod	v28.00.xxx.mod	Not supported ^(a)	Not supported

Table 2. Minimum firmware levels required (continued)

Device	One or no WCSs	Multiple WCS-SB, or -SD and/or an RH sensor module (WCS-SH)	WCS-SO/SCO ₂	WCS-SB/R
BCI-R	v5.02.xxx.mod	v6.00.xxx.mod	v7.0	Not supported
RTRM	v12 or higher (requires physical board replacement)	N/A	N/A	N/A
Tracer® TU	v8.2	v8.6	v9.3	v9.3
TU Adapter	v1.00.xxx.mod	N/A	N/A	N/A
WCI	v1.00.000.mod	v2.00.000.mod	v2.01.004.mod	v2.01.004.mod
Tracer® SC+	v5.1	v5.1	v5.1	v5.1
BCI2-I	All versions	All versions	Not supported ^(a)	Not supported
BCI2-R	All versions	All versions	All versions	Not supported
BCI2-C	N/A	N/A	N/A	N/A
Symbio™ 210/210e	All versions	All versions	All versions	All versions
Symbio™ 400-B/500	All versions	All versions	All versions	All versions
Symbio™ 700	All versions	All versions	All versions	All versions
Symbio™ 800	All versions	All versions	All versions	All versions

(a) The WCS-SO/SCO₂ sensor can be installed in another controller in the building and referenced to BCI-I/BCI2-I.

Trane - by Trane Technologies (NYSE: TT), a global climate innovator - creates comfortable, energy efficient indoor environments for commercial and residential applications. For more information, please visit trane.com or tranetechnologies.com.

Trane has a policy of continuous product and product data improvement and reserves the right to change design and specifications without notice. We are committed to using environmentally conscious print practices.