



Installation Instructions

Tracer® SC+ System Controller

Order Numbers:
X13651695001 (SC+)
Note: Includes 18 months software maintenance plan.

Packaged Contents

- One (1) Tracer SC+ module
- Two (2) 4-position terminal block plugs
- Six (6) 3-position terminal block plugs
- One (1) Installation sheet

X3964132001

SAFETY WARNING

Only qualified personnel should install and service the equipment. The installation, starting up, and servicing of heating, ventilating, and air-conditioning equipment can be hazardous and requires specific knowledge and training. Improperly installed, adjusted or altered equipment by an unqualified person could result in death or serious injury. When working on the equipment, observe all precautions in the literature and on the tags, stickers, and labels that are attached to the equipment.

March 2026

BAS-SVN037G-EN
©2026 Trane



Warnings, Cautions, and Notices

Read this manual thoroughly before operating or servicing this unit. Safety advisories appear throughout this manual as required. Your personal safety and the proper operation of this machine depend upon the strict observance of these precautions.

The three types of advisories are defined as follows:

- WARNING** Indicates a potentially hazardous situation which, if not avoided, could result in death or serious injury.
- CAUTION** Indicates a potentially hazardous situation which, if not avoided, could result in minor or moderate injury. It could also be used to alert against unsafe practices.
- NOTICE** Indicates a situation that could result in equipment or property-damage only accidents.

Important Environmental Concerns

Scientific research has shown that certain man-made chemicals can affect the earth's naturally occurring stratospheric ozone layer when released to the atmosphere. In particular, several of the identified chemicals that may affect the ozone layer are refrigerants that contain Chlorine, Fluorine and Carbon (CFCs) and those containing Hydrogen, Chlorine, Fluorine and Carbon (HCFCs). Not all refrigerants containing these compounds have the same potential impact to the environment. Trane advocates the responsible handling of all refrigerants.

Important Responsible Refrigerant Practices

Trane believes that responsible refrigerant practices are important to the environment, our customers, and the air conditioning industry. All technicians who handle refrigerants must be certified according to local rules. For the USA, the Federal Clean Air Act (Section 608) sets forth the requirements for handling, reclaiming, recovering and recycling of certain refrigerants and the equipment that is used in these service procedures. In addition, some states or municipalities may have additional requirements that must also be adhered to for responsible management of refrigerants. Know the applicable laws and follow them.

2

WARNING

Proper Field Wiring and Grounding Required!
Failure to follow code could result in death or serious injury. All field wiring MUST be performed by qualified personnel. Improperly installed and grounded field wiring poses FIRE and ELECTROCUTION hazards. To avoid these hazards, you MUST follow requirements for field wiring installation and grounding as described in NEC and your local/state/national electrical codes.

WARNING

Personal Protective Equipment (PPE) Required!
Failure to wear proper PPE for the job being undertaken could result in death or serious injury. Technicians, in order to protect themselves from potential electrical, mechanical, and chemical hazards, MUST follow precautions in this manual and on the tags, stickers, and labels, as well as the instructions below:

- Before installing/servicing this unit, technicians MUST put on all PPE required for the work being undertaken (Examples; cut resistant gloves/sleeves, butyl gloves, safety glasses, hard hat/bump cap, fall protection, electrical PPE and arc flash clothing). ALWAYS refer to appropriate Safety Data Sheets (SDS) and OSHA guidelines for proper PPE.
- When working with or around hazardous chemicals, ALWAYS refer to the appropriate SDS and OSHA/GHS (Global Harmonized System of Classification and Labeling of Chemicals) guidelines for information on allowable personal exposure levels, proper respiratory protection and handling instructions.
- If there is a risk of energized electrical contact, arc, or flash, technicians MUST put on all PPE in accordance with OSHA, NFPA 70E, or other country-specific requirements for arc flash protection, PRIOR to servicing the unit. NEVER PERFORM ANY SWITCHING, DISCONNECTING, OR VOLTAGE TESTING WITHOUT PROPER ELECTRICAL PPE AND ARC FLASH CLOTHING. ENSURE ELECTRICAL METERS AND EQUIPMENT ARE PROPERLY RATED FOR INTENDED VOLTAGE.

3

WARNING

Follow EHS Policies!
Failure to follow instructions below could result in death or serious injury.

- All Trane personnel must follow the company's Environmental, Health and Safety (EHS) policies when performing work such as hot work, electrical, fall protection, lockout/tagout, refrigerant handling, etc. Where local regulations are more stringent than these policies, those regulations supersede these policies.
- Non-Trane personnel should always follow local regulations.

NOTICE

Risk of Battery Exploding!
Failure to follow instructions below could cause the battery to explode resulting in equipment damage. Do NOT use a non-compatible battery with the controller! It is critical that a compatible battery be used.

Risque d'Explosion de la Pile!
Le non-respect des instructions qui suivent pourrait provoquer l'explosion de la pile et des dégâts à l'équipement. Ne PAS utiliser de pile non compatible avec le contrôleur! Il est très important qu'une pile compatible soit utilisée.

Copyright

This document and the information in it are the property of Trane, and may not be used or reproduced in whole or in part without written permission. Trane reserves the right to revise this publication at any time, and to make changes to its content without obligation to notify any person of such revision or change.

Trademarks

All trademarks referenced in this document are the trademarks of their respective owners.

Revision History

- Updated USB port current draw table.
- Updated Accessories table.

4

Note: Compatible battery - BR2032.

Required Tools

- 5/16 in. (8 mm) slotted screwdriver
- 1/8 in. (3 mm) slotted screwdriver

Specifications

Table 1. Tracer SC+ specifications

Power Requirements	
24 Vac @ 30 VA Class 2	
Tracer plug-in power supply with single barrel connector- Output: 0.75A max at 24 Vdc @ 50C. Polarity: outer ground, inner 24 Vdc	
PM014 power supply module through inter-module-communication bus (IMC) - Output: 1.4A max @ 24 Vdc @ 70C	
Min/Max Ratings 24VAC +/- 15%, 24VDC +/- 10%	
Storage	
Temperature:	-40°C to 70°C (-40°F to 158°F)
Relative humidity:	Between 5% to 95% (non-condensing)
Operating Environment	
Temperature:	-40°C to 70°C (-40°F to 158°F) when powered with 24Vdc and maximum USB current draw of 500 mA.
	-40°C to 50°C (-40°F to 122°F) with maximum USB current draw of 1000 mA for all other configurations.
Operating Environment	
Humidity:	Between 10% to 90% (non-condensing)
Product weight:	1 kg (2.2 lb.)
Altitude:	Maximum 2,000 m (6,500 ft.)
Installation:	Category 3
Pollution	Degree 2

5

Mounting the Tracer SC+

- The mounting location must meet the temperature and humidity specifications as outlined in Table 1.
- Do not mount on a flat surface, such as on a floor or on top of a table. Mount in an upright position with the front facing outward.

To mount the Tracer SC+:

1. Hook the top half of the Tracer SC+ on to the DIN rail.
2. Gently push on the lower half of the Tracer SC+ until the release clip snaps into place.

Figure 1. Mounting the Tracer SC+

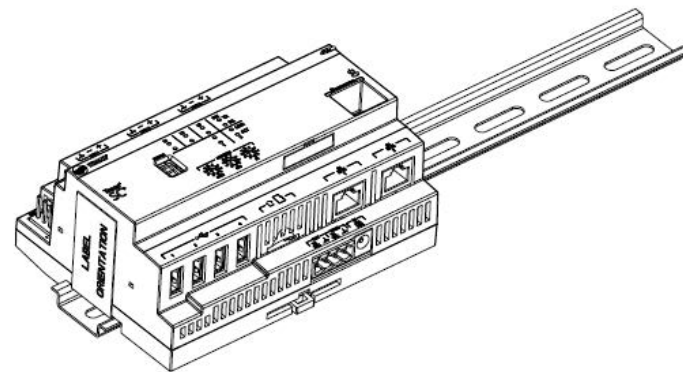

Removing or Repositioning the Tracer SC+

To remove or reposition the Tracer SC+ from a DIN rail:

1. Insert a screwdriver into the slotted release clip and gently pry upward on the clip with the screwdriver, **OR**;
If the screwdriver fits the slot size, insert the screwdriver into the slotted release clip and rotate it to the left or right to release tension on the clip.

6

2. While holding tension on the slotted release clip, lift the Tracer SC+ upward to remove or reposition.
3. If repositioning, push on the Tracer SC+ until the slotted release clip snaps back into place.

Figure 2. Removing the Tracer SC+

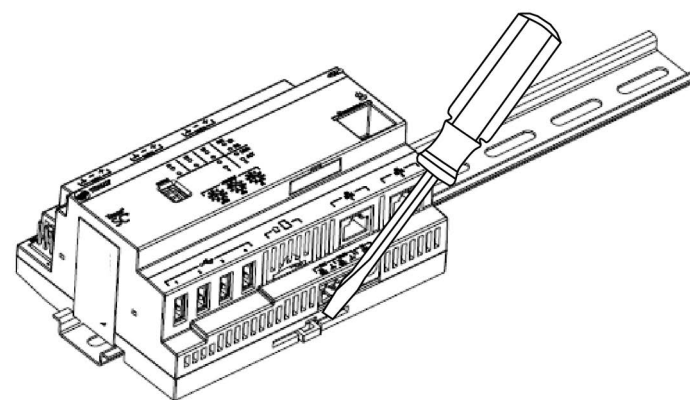

Wiring and Applying Power

The Tracer SC+ controller can be powered in one of three ways:

- 24 Vac @ 30 VA Class 2 connected to 4-position terminal block.
- Tracer plug-in power supply with single barrel connector.
 - Output: 0.75 A max at 24 Vdc @ 50 C. Polarity: outer ground, inner 24 Vdc
- PM014 power supply module through inter-module-communication bus (IMC).
 - Output: 1.4A max @ 24 Vdc @ 70C. See *Power Supply Module PM014 Installation, Operation, and Maintenance* (BAS-SVX33*-EN).

7

Direct Current Requirements for SC+ and Peripherals

Tracer SC+ output is 24 Vdc. Table 2 provides the current draw per component for DC power budgeting.

Table 2. 24 Vdc current draw per components on an SC+

Component	Current draw
SC+ Controller	150 mA
WCI	10 mA
XM30	120 mA
XM32	100 mA

Table 3. USB port current draw

Component	5 Vdc Current draw	24 Vdc Current draw
Each USB Port	500 mA Max	125 mA
Trane Wi-Fi Module (X13651743001)	250 mA	63 mA
Trane U60 LON Adapter	110 mA	28 mA
Trane USB Cellular Module (Version, USA)	500 mA	125 mA
Trane Isolated Comm 3 Module CM31 (X13651812001)	50 mA	13 mA
Communication module CM2 (X13651810001)	225mA	58mA

Note: Total for all 4 ports: 1000 mA at 50°C or colder, 500 mA at 70°C.

Tracer® SC+ DC Power Budget

Depending on the power source, Tracer® SC+ has a maximum current available for peripheral devices. Perform a power budget if you have more than 3 external devices connected through the IMC.

- AC powered
 - The preferred power method is to provide 24 Vac from a transformer. Using the values from [Table 2](#), add together the current draw for all the components connected to the SC+. If the sum exceeds 600mA, use a PM014 module or a plug-in power supply.
- Tracer® plug-in power supply
 - Using the values from [Table 2](#), add together the current draw for all the components connected to the SC+. The sum cannot exceed 0.75A. If the sum exceeds 750mA, use a PM014 module.
- PM014 powered
 - Using the values from [Table 2](#), add together the power draw for all the components connected to the SC+. The sum cannot exceed the 1.4A.

Transformer (Preferred Method)

This procedure involves wiring 24Vac to the XFMR pins of the 4-position terminal block on the Tracer® SC+ controller. See [Figure 3](#) for details.

1. Using the provided 4-position terminal block, wire the 24 Vac input connection of the Tracer SC+ to a dedicated 24 Vac, Class 2 transformer.
2. Ensure that the Tracer SC+ is properly grounded.

Important: This device must be grounded for proper operation! The factory-supplied ground wire must be connected from any chassis ground connection on the device to an appropriate earth ground. The chassis ground connection can be the 24 Vac transformer input at the device, or any other chassis ground connection on the device.

Note: The Tracer SC+ is NOT grounded through the DIN rail connection.

3. Apply power to the Tracer SC+ by pressing the power button. All status LEDs illuminate and the following sequence flashes on the 7-segment display: 8, 7, 5, 4, L, dancing dash pattern. The dancing dashes continue while the Tracer SC+ is operating normally.

Tracer® Plug-in Power Supply with Single Barrel Connector

1. Connect the power supply to a standard power receptacle, such as a wall outlet.
2. Connect the barrel end of the power supply to the 24 Vdc input of the Tracer® SC+.
3. Ensure that the Tracer SC+ is properly grounded.

Important: This device must be grounded for proper operation! The factory-supplied ground wire must be connected from any chassis ground connection on the device to an appropriate earth ground.

Note: The Trace SC+ is NOT grounded through the DIN rail connection.

4. Apply power to the Tracer SC+ by pressing the power button. All status LEDs illuminate and the following sequence flashes on the 7-segment display: 8, 7, 5, 4, L, dancing dash pattern. The dancing dashes continue while the Tracer SC+ is operating normally.

PM014 Power Supply Module through IMC Bus

This procedure involves connecting the SC+ to the a PM014 power supply using an IMC cable. See [Figure 4](#) for details.

Note: For complete instructions and more information, refer to the Power Supply Module PM014 Installation, Operation, and Maintenance (BAS-SVX33*-EN).

1. Connect one end of the provided IMC power cable to the IMC connection on the Tracer® SC+. Connect the other end of the IMC power cable to the IMC connection on the power supply module.
2. Wire the 24 Vac input connection on the PM014 power supply to a dedicated Class 2 transformer.
3. Ensure that the Tracer SC+ and the PM014 power supply are properly grounded through the DIN rail connection.

Important: This device must be grounded for proper operation! The factory-supplied ground wire must be connected from any chassis ground connection on the device to an appropriate earth ground. The chassis ground connection can be the 24 Vac transformer input at the device, or any other chassis ground connection on the device.

Note: The Tracer SC+ is NOT grounded through the DIN rail connection.

4. Apply power to the Tracer® SC+ by pressing the power button. All status LEDs illuminate and the following sequence flashes on the 7-segment display: 8, 7, 5, 4, L, dancing dash pattern. The dancing dashes continue while the Tracer® SC+ is operating normally.

Figure 3. Apply power using a class 2 transformer

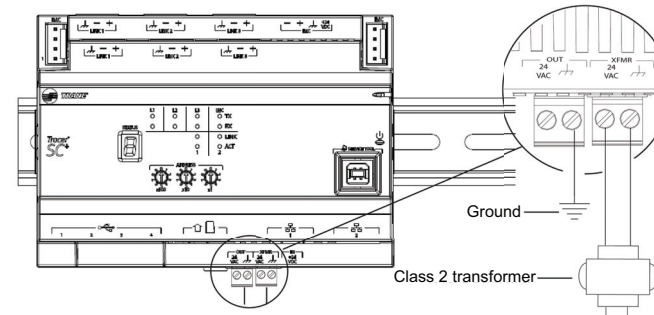

Figure 4. Apply power using a PM014 power supply module

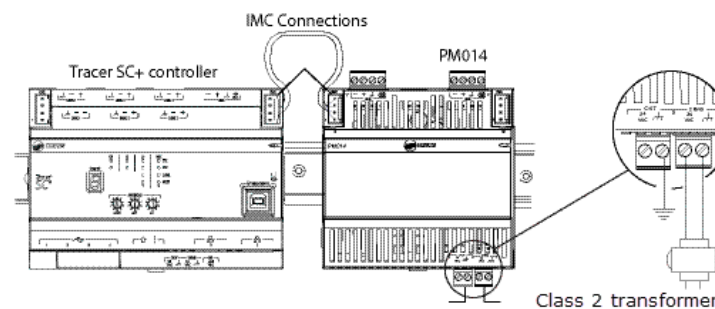

Table 7. Key software licenses

Service Part #	Part Number	Description
N/A	BMCF000AAA0DB00	15 Dev Core App License
N/A	BMCF000AAA0BH00	CPC App License
N/A	BMCF000AAA0DA00	240 Dev Demo License
N/A	BMCF000AAA0EA00	1 Year SMP
N/A	BMCF000AAA0EB00	3 Year SMP
N/A	BMCF000AAA0EC00	5 Year SMP
N/A	BMCF000AAA0ED00	Expired SMP

Note: See Tracer SC+ System Controller Installation, Operation, and Maintenance guide BAS-SVX077*-EN for a complete list of licenses.

Tracer BACnet Terminator

A Tracer® BACnet® terminator is placed at the end of each communication link in order to decrease communication signal degradation.

Refer to the BACnet® MS/TP Wiring and Link Performance Best Practices and Troubleshooting Installation, Operation, and Maintenance (BAS-SVX51*-EN).

Figure 5. BACnet terminator (wiring)

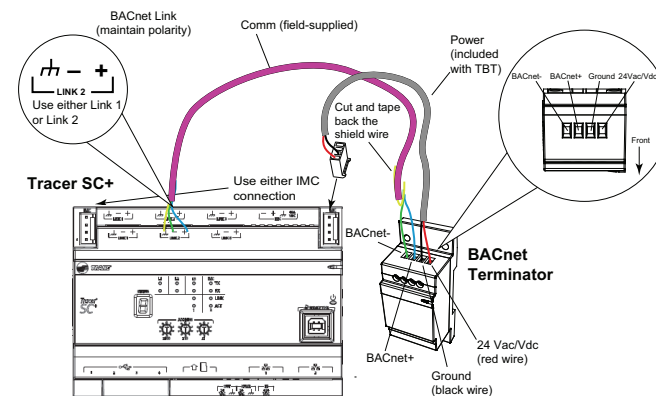

Agency Listings and Compliance

The European Union (EU) Declaration of Conformity is available from your local Trane® office.

Service Parts

Table 4. Hardware and bundles

Service Part #	Part Number	Description
KIT18461 ^(a)	X13651695001	Tracer® SC+ Hardware

(a) Includes 18 months software maintenance plan.

Table 5. Accessories

Service Part #	Part Number	Description
MOD01702	X13651538010	PM014 24 Vac to 1.4A 24 Vdc
PLU1323	X13770352001	Plug-in Power Supply
KIT18458	X13651698001	Tracer® USB Lon Module
MOD01786	X1365152401	Trane BACnet Terminator (TBT)
MOD03121	X13651743001, 2	Tracer® USB Wifi Module
KIT18459	X13690281001	Micro SD Card
N/A	X13651812001	Isolated Comm 3 Module CM3I
N/A	BMCL100US0100000	Tracer® USB Cellular Module, NB, 1M Cable
N/A	BMCL100USB100000	Tracer® USB Cellular Module, 1M Cable
N/A	BMCL100USB290000	Tracer® USB Cellular Module, 2.9M Cable
N/A	X13651810001	Communication Module CM2

Table 6. Enclosures

Service Part #	Part Number	Description
N/A	X13651559010	Medium Enclosure (120 Vac, 1 outlet)
N/A	X13651699001	Medium Enclosure (120 Vac, 3 outlet)
N/A	X13651560010	Medium Enclosure (230 Vac, 0 outlet)

Trane - by Trane Technologies (NYSE: TT), a global climate innovator - creates comfortable, energy efficient indoor environments for commercial and residential applications. For more information, please visit trane.com or tranetechnologies.com.

Trane has a policy of continuous product and product data improvement and reserves the right to change design and specifications without notice. We are committed to using environmentally conscious print practices.