

# Installation Guide

# Electric Heaters

## Split System Air Handlers, 5-25 Tons

### **BAYHTRR/BAYHTRT/BAYHTRS/BAYHTRP:**

Used with TWE051, TWE060, TWE072,  
TWE076, TWE090, TWE101, TWE120,  
TWE126, TWE150, TWE156, TWE180,  
TWE201, TWE240, TWE251, TWE300

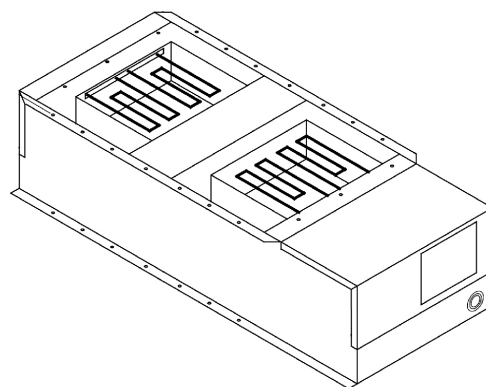

### **▲ SAFETY WARNING**

Only qualified personnel should install and service the equipment. The installation, starting up, and servicing of heating, ventilating, and air-conditioning equipment can be hazardous and requires specific knowledge and training. Improperly installed, adjusted or altered equipment by an unqualified person could result in death or serious injury. When working on the equipment, observe all precautions in the literature and on the tags, stickers, and labels that are attached to the equipment.

# Introduction

Read this manual thoroughly before operating or servicing this unit.

## Warnings, Cautions, and Notices

Safety advisories appear throughout this manual as required. Your personal safety and the proper operation of this machine depend upon the strict observance of these precautions.

The three types of advisories are defined as follows:



Indicates a potentially hazardous situation which, if not avoided, could result in death or serious injury.



Indicates a potentially hazardous situation which, if not avoided, could result in minor or moderate injury. It could also be used to alert against unsafe practices.

**NOTICE**

Indicates a situation that could result in equipment or property-damage only accidents.

## Important Environmental Concerns

Scientific research has shown that certain man-made chemicals can affect the earth's naturally occurring stratospheric ozone layer when released to the atmosphere. In particular, several of the identified chemicals that may affect the ozone layer are refrigerants that contain Chlorine, Fluorine and Carbon (CFCs) and those containing Hydrogen, Chlorine, Fluorine and Carbon (HCFCs). Not all refrigerants containing these compounds have the same potential impact to the environment. Trane advocates the responsible handling of all refrigerants.

## Important Responsible Refrigerant Practices

Trane believes that responsible refrigerant practices are important to the environment, our customers, and the air conditioning industry. All technicians who handle refrigerants must be certified according to local rules. For the USA, the Federal Clean Air Act (Section 608) sets forth the requirements for handling, reclaiming, recovering and recycling of certain refrigerants and the equipment that is used in these service procedures. In addition, some states or municipalities may have additional requirements that must also be adhered to for responsible management of refrigerants. Know the applicable laws and follow them.

### **WARNING**

#### **Proper Field Wiring and Grounding Required!**

Failure to follow code could result in death or serious injury.

**All field wiring MUST be performed by qualified personnel. Improperly installed and grounded field wiring poses FIRE and ELECTROCUTION hazards. To avoid these hazards, you MUST follow requirements for field wiring installation and grounding as described in NEC and your local/state/national electrical codes.**

### **WARNING**

#### **Personal Protective Equipment (PPE) Required!**

Failure to wear proper PPE for the job being undertaken could result in death or serious injury.

Technicians, in order to protect themselves from potential electrical, mechanical, and chemical hazards, **MUST** follow precautions in this manual and on the tags, stickers, and labels, as well as the instructions below:

- **Before installing/servicing this unit, technicians MUST put on all PPE required for the work being undertaken (Examples; cut resistant gloves/sleeves, butyl gloves, safety glasses, hard hat/bump cap, fall protection, electrical PPE and arc flash clothing). ALWAYS refer to appropriate Safety Data Sheets (SDS) and OSHA guidelines for proper PPE.**
- **When working with or around hazardous chemicals, ALWAYS refer to the appropriate SDS and OSHA/GHS (Global Harmonized System of Classification and Labelling of Chemicals) guidelines for information on allowable personal exposure levels, proper respiratory protection and handling instructions.**
- **If there is a risk of energized electrical contact, arc, or flash, technicians MUST put on all PPE in accordance with OSHA, NFPA 70E, or other country-specific requirements for arc flash protection, PRIOR to servicing the unit. NEVER PERFORM ANY SWITCHING, DISCONNECTING, OR VOLTAGE TESTING WITHOUT PROPER ELECTRICAL PPE AND ARC FLASH CLOTHING. ENSURE ELECTRICAL METERS AND EQUIPMENT ARE PROPERLY RATED FOR INTENDED VOLTAGE.**

**⚠ WARNING****Follow EHS Policies!**

Failure to follow instructions below could result in death or serious injury.

- All Trane personnel must follow the company's Environmental, Health and Safety (EHS) policies when performing work such as hot work, electrical, fall protection, lockout/tagout, refrigerant handling, etc. Where local regulations are more stringent than these policies, those regulations supersede these policies.
- Non-Trane personnel should always follow local regulations.

**⚠ WARNING****R-454B Flammable A2L Refrigerant!**

Failure to use proper equipment or components as described below could result in equipment failure, and possibly fire, which could result in death, serious injury, or equipment damage.

The equipment described in this manual uses R-454B refrigerant which is flammable (A2L). Use ONLY R-454B rated service equipment and components. For specific handling concerns with R-454B, contact your local representative.

## Copyright

This document and the information in it are the property of Trane, and may not be used or reproduced in whole or in part without written permission. Trane reserves the right to revise this publication at any time, and to make changes to its content without obligation to notify any person of such revision or change.

## Trademarks

All trademarks referenced in this document are the trademarks of their respective owners.

## Revision History

- Updated model numbers on the front cover.
- Updates to the Heater compatibility table in the Pre-Installation section.

# Table of Contents

Pre-Installation .....	5	Low Voltage Wires (24 Volts) .....	6
Inspection .....	5	High Voltage Wires .....	7
General .....	5	Wiring Diagrams .....	10
Parts List .....	5		
Installation .....	6		

# Pre-Installation

## Inspection

Remove the contents of the kit from the shipping package and check carefully for shipping damage. If any damage is found, report it immediately, and file a claim against the transportation company. Any missing parts should be immediately reported to your supplier and replaced with authorized parts only.

## General

These instructions are for the installation of electric heaters into the split system heat pump and cooling unit air handlers. Unit-to-heater match up is described in the table that follows.

These air handlers and heaters are designed so that all Class I (high voltage) wiring between the heater and unit is accomplished by the method of hard wiring. Class II wiring (low voltage) is accomplished by push-on type wire connectors.

Find the heater model number on the heater nameplate. Check the heater compatibility table that follows to ensure

the heater selected is approved for use with the air handler in which it is to be installed, and that the power supply is compatible with this heater.

## Parts List

Qty	Description
1	Heater (with enclosure)
2	Cable clamps
2	Screws (for cable clamp)
2	Adapter harnesses
2	Bullet wire ties
4	Regular wire ties
1	Plastic bushing
11 or 20	Screws (depending on heater kit)
1	Gasket

**Table 1. Heater compatibility**

Unit Model	Voltage	Phase	Heaters
TWE060*1	208-230	1	BAYHTRP106*, BAYHTRS112*, BAYHTRT117*, BAYHTRS123*
TWE060*3	208-230	3	BAYHTRP305*, BAYHTRS310*, BAYHTRS315*, BAYHTRP325*
TWE060*W	575	3	BAYHTRPW05*, BAYHTRSW10*, BAYHTRSW15*, BAYHTRPW25*
TWE090*1, TWE120*1	208-230	1	BAYHTRP106*, BAYHTRS112*, BAYHTRT117*, BAYHTRS123*, BAYHTRP129*
TWE072*3, TWE090*3, TWE120*3	208-230	3	BAYHTRP305*, BAYHTRS310*, BAYHTRS315*, BAYHTRP325*
TWE090*3, TWE120*3	208-230	3	BAYHTRP335*
TWE101*D	380-151/50Hz	3	BAYHTRP435*
TWE051*D, TWE060*4, TWE072*D, TWE072*4, TWE076*D, TWE090*4, TWE101*D, TWE120*4	380-415/50Hz 460V/60Hz	3	BAYHTRP405*, BAYHTRS410*, BAYHTRS415*, BAYHTRP425*
TWE090*4, TWE120*4	460V/60Hz	3	BAYHTRP435*
TWE072*W, TWE090*W, TWE120*W	575	3	BAYHTRPW05*, BAYHTRSW10*, BAYHTRSW15*, BAYHTRPW25*
TWE090*W, TWE120*W	575	3	BAYHTRPW35*
TWE150*3, TWE180*3, TWE240*3, TWE300*3	208-230	3	BAYHTRT310*, BAYHTRR320*, BAYHTRR330*, BAYHTRR350*
TWE126*D, TWE150*4, TWE156*D, TWE180*4, TWE201D, TWE240*4, TWE251*D, TWE300*4	380-415/50Hz 460V/60Hz	3	BAYHTRT410*, BAYHTRR420*, BAYHTRR430*, BAYHTRR450*
TWE150*W, TWE180*W, TWE240*W, TWE300*W	575	3	BAYHTRTW10*, BAYHTRRW20*, BAYHTRRW30*, BAYHTRRW50*

Voltages indicated are for Air Handlers.

For heater rated voltages, see heater nameplates.

# Installation

## ⚠ WARNING

### Rotating Components!

Failure to disconnect power before servicing could result in rotating components cutting and slashing technician which could result in death or serious injury.

Disconnect all electric power, including remote disconnects before servicing. Follow proper lockout/tagout procedures to ensure the power can not be inadvertently energized.

**Note:** All phases of this installation must comply with national, state, and local codes.

1. Remove duct flange from around air discharge on top of the air handler. Retain screws and flange for (optional) installation on top of the heater. See [Figure 1, p. 6](#) and [Figure 2, p. 6](#).
2. Remove the control wire knockout (Knockout #1) from

**Figure 1. Top of air handler single blower**

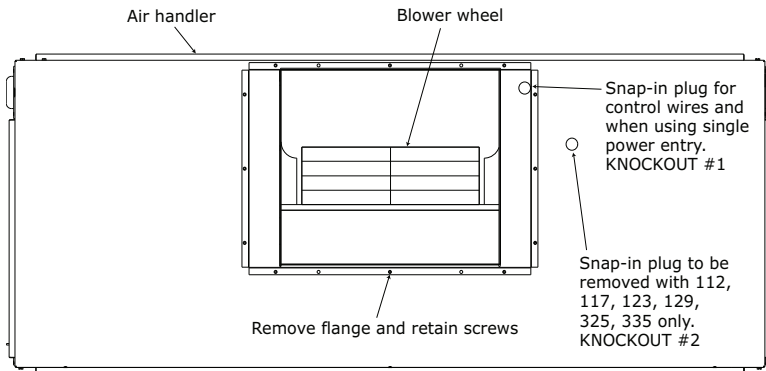

**Figure 2. Top of air handler dual blower**

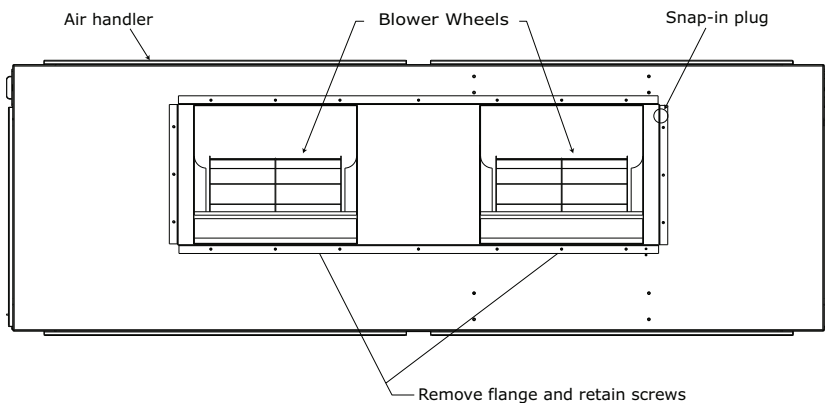

top of air handler and insert plastic bushing supplied with heater. This knockout will also be used if single point power entry is utilized.

**Important:** For ventilation purposes, Heaters 112, 117, 123, 129, 325, and 335 require that an additional knockout (knockout #2) be removed (see [Figure 1, p. 6](#)). When using BAYHTR\*325 with a TWE060\*3 (5 ton) air handler, the heater baffle must be removed (see [Figure 3, p. 7](#)).

3. Remove air handler access panel and control box cover.

**Note:** Apply gasket to heater see heater gasket installation sheet.

4. Place heater on air handler and secure in place with the screws provided.

## Low Voltage Wires (24 Volts)

The heater kit includes two adapter harnesses for the low voltage wiring. If heater control box is equipped with a low voltage terminal block, use the adapter harness in the kit that has PPM13 and quick connect terminations. If the low

voltage terminal block is not present and the control box is equipped with Symbio 700 controller, use the adapter harness with PPM13 and PPF14 attached. Refer to the schematics for the appropriate connection points.

1. If the heater control box is equipped with a low voltage

terminal block, there will be 1 brown wire and 1 black wire for a single-stage heat control connection. For two-stage heat, there will be 1 brown wire, 1 black wire, and 1 orange wire.

2. Route the 2 or 3 low voltage wires down through the plastic bushing in the knockout #1 to the low voltage terminal block see [Figure 4, p. 8](#) and [Figure 5, p. 9](#). Wire according to heater wiring diagram.
3. Wire ties and cable clamps supplied should be used to secure the wires from the heater to the air handler control box in a location that will not allow them to interfere with any moving parts.

## High Voltage Wires

### NOTICE

#### Use Copper Conductors Only!

Failure to use copper conductors could result in equipment damage as the equipment was not designed or qualified to accept other types of conductors.

1. For single point power entry, route 2 or 3 red wires, down through the plastic bushing in knockout #1 and into the air handler control box.
2. For single phase there will be 2 red wires, and for 3 phase there will be 3 red wires.
3. The 2 or 3 red wires should be hard wired to the bottom contacts of the air handler contactor per the wiring diagram for the standard air handlers. For the 2-speed VFD and SZVAV the wires connect to the fuse block.

**Important:** When the dual point power entry option is used, the high voltage wires, for single point power entry, should remain capped, coiled up and clamped inside the heater control box.

4. When using dual point power entry, knockouts on the control end of both the air handler and the heater are to be used. See [Figure 4, p. 8](#) and [Figure 5, p. 9](#) for

location of each.

5. Replace air handler control box cover.
6. Replace air handler access panel.
7. Replace control box panel on accessory heater.
8. Check blower rotation. If incorrect, change positions of any two power leads at fan contactor (F) or fuse block. After electrical hookup has been completed, duct work can be assembled. The duct flanges removed from the air handler, can be secured in place on top of the heater and the duct work can be attached or the flange can be discarded and the duct can be fashioned to fit up to the heater.

Figure 3. End view

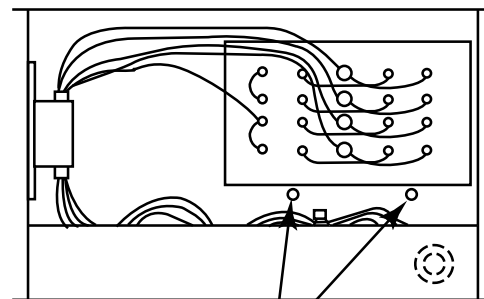

END VIEW

Loosen screws to remove baffle

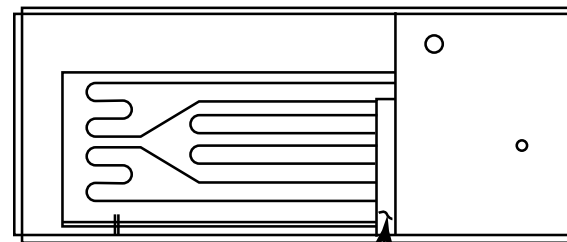

BOTTOM VIEW

Baffle

**Figure 4. Heater installation hook-up with standard air handler**

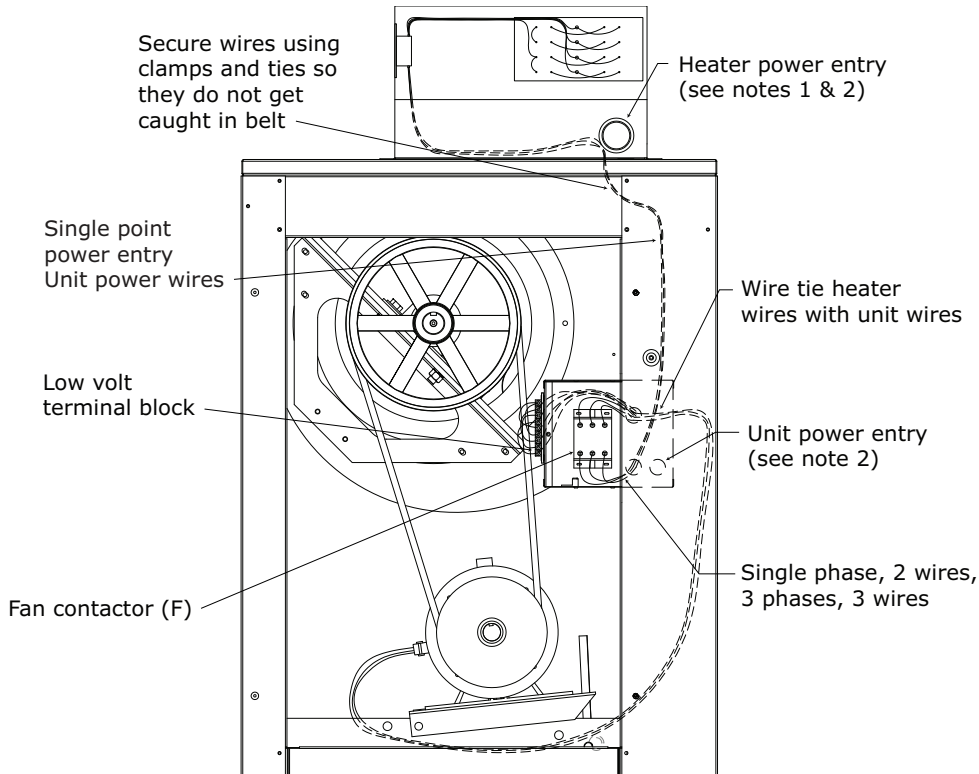

**Notes:**

1. For power supply to heater only see the heater nameplate to determine "MCA" and over current protection device values.
2. For single point power entry option (heater and blower motor) see the "heater installed" nameplate on the air handler for "MCA" and over current protection device values.
3. When electric heater accessory is used single point power entry or dual point power entry is field optional. Single point power entry option is through electric heater only.



**Figure 5. Heater installation hook-up with 2-speed VFD and SZVAV**

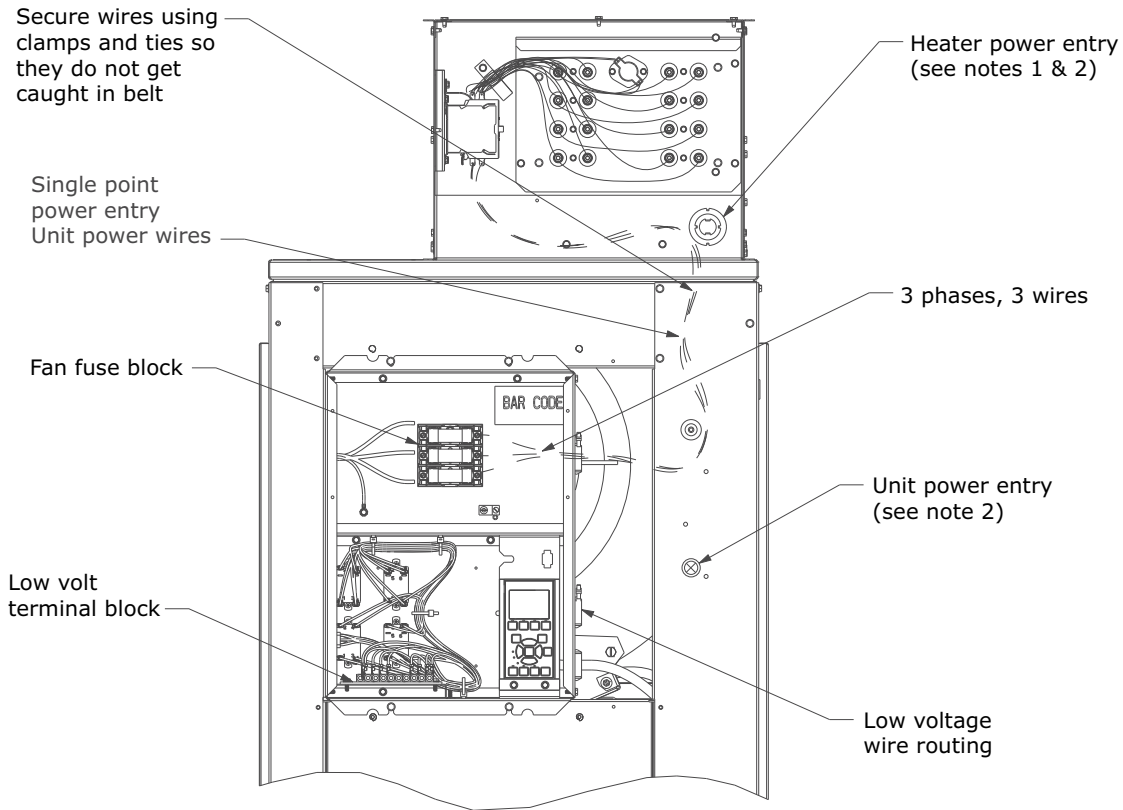

**Notes:**

1. For power supply to heater only see the heater nameplate to determine "MCA" and over current protection device values.
2. For single point power entry option (heater and blower motor) see the "heater installed" nameplate on the air handler for "MCA" and over current protection device values.
3. When electric heater accessory is used single point power entry or dual point power entry is field optional. Single point power entry option is through electric heater only.

# Wiring Diagrams

**Table 2. Wiring diagram matrix**

Voltage	Diagram Number	Description
208-240V	436758590001	DIAGRAM; SCHEMATIC/CONNECTION, ELECTRIC HEAT 12.98/17.28KW 208-240V/1PH
	436757600001	DIAGRAM; SCHEMATIC/CONNECTION, ELECTRIC HEAT 37.42/49.84KW 208-240V/3PH
	436757610001	DIAGRAM; SCHEMATIC/CONNECTION, ELECTRIC HEAT 3.7/5KW or 7.48/9.96KW 208-240V/3PH
	436757620001	DIAGRAM; SCHEMATIC/CONNECTION, ELECTRIC HEAT 11.25/14.96KW 208-240V/3PH
	436757630001	DIAGRAM; SCHEMATIC/CONNECTION, ELECTRIC HEAT 18.71/24.92KW 208-240V/3PH
	436757640001	DIAGRAM; SCHEMATIC/CONNECTION, ELECTRIC HEAT 26.20/34.88KW 208-240V/3PH
	436757690001	DIAGRAM; SCHEMATIC/CONNECTION, ELECTRIC HEAT 14.96/19.92KW 208-240V/3PH
	436757700001	DIAGRAM; SCHEMATIC/CONNECTION, ELECTRIC HEAT 7.50/10.0KW 208-240V/3PH
	436757710001	DIAGRAM; SCHEMATIC/CONNECTION, ELECTRIC HEAT 4.33/5.76KW 208-240V/1PH
	436757730001	DIAGRAM; SCHEMATIC/CONNECTION, ELECTRIC HEAT 8.65/11.52KW 208-240V/1PH
	436757740001	DIAGRAM; SCHEMATIC/CONNECTION, ELECTRIC HEAT 17.30/23.04KW 208-240V/1PH
	436757750001	DIAGRAM; SCHEMATIC/CONNECTION, ELECTRIC HEAT 21.65/28.80KW 208-240V/1PH
	436757760001	DIAGRAM; SCHEMATIC/CONNECTION, ELECTRIC HEAT 22.50/29.92KW 208-240V/3PH
460/575V	436766640001	DIAGRAM; SCHEMATIC/CONNECTION, ELECTRIC HEAT 5.00/9.96KW 460/575V/3PH
	436766650001	DIAGRAM; SCHEMATIC/CONNECTION, ELECTRIC HEAT 14.96KW 460/575V/3PH
	436766660001	DIAGRAM; SCHEMATIC/CONNECTION, ELECTRIC HEAT 24.92KW 460/575V/3PH
	436766670001	DIAGRAM; SCHEMATIC/CONNECTION, ELECTRIC HEAT 34.88KW 460/575V/3PH
	436766680001	DIAGRAM; SCHEMATIC/CONNECTION, ELECTRIC HEAT 10.0/19.92KW 460/575V/3PH
	436766690001	DIAGRAM; SCHEMATIC/CONNECTION, ELECTRIC HEAT 49.84KW 460/575V/3PH
	436766700001	DIAGRAM; SCHEMATIC/CONNECTION, ELECTRIC HEAT 29.92KW 460/575V/3PH



Trane and American Standard create comfortable, energy efficient indoor environments for commercial and residential applications. For more information, please visit [trane.com](http://trane.com) or [americanstandardair.com](http://americanstandardair.com).

Trane and American Standard have a policy of continuous product and product data improvement and reserve the right to change design and specifications without notice. We are committed to using environmentally conscious print practices.

ACC-SVN91L-EN 11 Aug 2024  
Supersedes ACC-SVN91K-EN (June 2022)

©2024