

Installation Instructions

Roof Curb Packaged Rooftop Air Conditioners 15 to 25 Tons

Model Number: BAYCURB027*
Used With: E/GCC180-300

SAFETY WARNING

Only qualified personnel should install and service the equipment. The installation, starting up, and servicing of heating, ventilating, and air-conditioning equipment can be hazardous and requires specific knowledge and training. Improperly installed, adjusted or altered equipment by an unqualified person could result in death or serious injury. When working on the equipment, observe all precautions in the literature and on the tags, stickers, and labels that are attached to the equipment.

September 2023

ACC-SVN73N-EN
©2023

4 Parts List

Table 1. Parts list

Quantity	Description
2	Side rails
2	End rails
2	Side curb flanges
1	End curb flange
4	Insulated block-off panels on BAYCURB027
-	Gasketing material
-	Sheet metal screws
3	Insulated divider/support panels

Roof Opening

For safety and sound considerations, do not cut out the entire roof deck within the curb area.

Roof Support

WARNING

Risk of Roof Collapsing!
Failure to ensure proper structural roof support could cause the roof to collapse, which could result in death or serious injury and property damage. Confirm with a structural engineer that the roof structure is strong enough to support the combined weight of the roofcurb, the unit, and any accessories. Refer to Table 3 and Table 4 for typical unit and curb weights.

The roof must support the weight of the unit, accessories, and the curb. See Figure 2 and Table 3 for center-of-gravity and corner weight information. Units may be set perpendicular or parallel to roof support members. The combined weight of the unit, accessories, and curb should be evenly spaced

1 Warnings, Cautions, and Notices

Read this manual thoroughly before operating or servicing this unit. Safety advisories appear throughout this manual as required. Your personal safety and the proper operation of this machine depend upon the strict observance of these precautions.

The three types of advisories are defined as follows:

- WARNING** Indicates a potentially hazardous situation which, if not avoided, could result in death or serious injury.
- CAUTION** Indicates a potentially hazardous situation which, if not avoided, could result in minor or moderate injury. It could also be used to alert against unsafe practices.
- NOTICE** Indicates a situation that could result in equipment or property-damage only accidents.

Important Environmental Concerns

Scientific research has shown that certain man-made chemicals can affect the earth's naturally occurring stratospheric ozone layer when released to the atmosphere. In particular, several of the identified chemicals that may affect the ozone layer are refrigerants that contain Chlorine, Fluorine and Carbon (CFCs) and those containing Hydrogen, Chlorine, Fluorine and Carbon (HCFCs). Not all refrigerants containing these compounds have the same potential impact to the environment. Trane advocates the responsible handling of all refrigerants-including industry replacements for CFCs such as HCFCs and HFCs.

Important Responsible Refrigerant Practices

Trane believes that responsible refrigerant practices are important to the environment, our customers, and the air conditioning industry. All technicians who handle refrigerants must be certified according to local rules. For the USA, the Federal Clean Air Act (Section 608) sets forth the requirements for handling, reclaiming, recovering and recycling of certain refrigerants and the equipment that is used in these service procedures. In addition, some states or municipalities may have additional requirements that must also be adhered to for responsible management of refrigerants. Know the applicable laws and follow them.

2 Warnings

WARNING

Proper Field Wiring and Grounding Required!
Failure to follow code could result in death or serious injury. All field wiring MUST be performed by qualified personnel. Improperly installed and grounded field wiring poses FIRE and ELECTROCUTION hazards. To avoid these hazards, you MUST follow requirements for field wiring installation and grounding as described in NEC and your local/state/national electrical codes.

WARNING

Personal Protective Equipment (PPE) Required!
Failure to wear proper PPE for the job being undertaken could result in death or serious injury. Technicians, in order to protect themselves from potential electrical, mechanical, and chemical hazards, MUST follow precautions in this manual and on the tags, stickers, and labels, as well as the instructions below:

- Before installing/servicing this unit, technicians MUST put on all PPE required for the work being undertaken (Examples; cut resistant gloves/sleeves, butyl gloves, safety glasses, hard hat/bump cap, fall protection, electrical PPE and arc flash clothing). ALWAYS refer to appropriate Safety Data Sheets (SDS) and OSHA guidelines for proper PPE.
- When working with or around hazardous chemicals, ALWAYS refer to the appropriate SDS and OSHA/GHS (Global Harmonized System of Classification and Labelling of Chemicals) guidelines for information on allowable personal exposure levels, proper respiratory protection and handling instructions.
- If there is a risk of energized electrical contact, arc, or flash, technicians MUST put on all PPE in accordance with OSHA, NFPA 70E, or other country-specific requirements for arc flash protection, PRIOR to servicing the unit. NEVER PERFORM ANY SWITCHING, DISCONNECTING, OR VOLTAGE TESTING WITHOUT PROPER ELECTRICAL PPE AND ARC FLASH CLOTHING. ENSURE ELECTRICAL METERS AND EQUIPMENT ARE PROPERLY RATED FOR INTENDED VOLTAGE.

3 Warnings

WARNING

Follow EHS Policies!
Failure to follow instructions below could result in death or serious injury.

- All Trane personnel must follow the company's Environmental, Health and Safety (EHS) policies when performing work such as hot work, electrical, fall protection, lockout/tagout, refrigerant handling, etc. Where local regulations are more stringent than these policies, those regulations supersede these policies.
- Non-Trane personnel should always follow local regulations.

Copyright

This document and the information in it are the property of Trane, and may not be used or reproduced in whole or in part without written permission. Trane reserves the right to revise this publication at any time, and to make changes to its content without obligation to notify any person of such revision or change.

Trademarks

All trademarks referenced in this document are the trademarks of their respective owners.

Revision History

Removed V2 model information in the document.

General Information

This manual describes the layout and installation procedures required to properly assemble and install the roof curb. Illustrations in Figure 1 reference dimensional data regarding roof opening construction.

Each curb package ships un-assembled, along with the required hardware and gasketing material.

Roof insulation, cant strips, flashing (if desired), and nails must be furnished by the installing contractor.

5
between a minimum of two supports. Confirm the curb position on the roof support does not interfere with the clearance required for the supply/return ductwork. See Figure 8 for ductwork location.

Clearances

Recommended clearances for single-unit installation are shown in Figure 1. These minimum requirements an important consideration when determining unit placement and essential for adequate serviceability, maximum capacity, and peak operating efficiency.

Any reduction of the unit clearances indicated in Figure 1 may result in condenser coil starvation, or the recirculation of warm condenser air. Actual clearances which appear to be inadequate should be reviewed with a local sales engineer.

Note: Unit weights are maximum valve of horizontal and downflow configuration.

Figure 1. Clearances

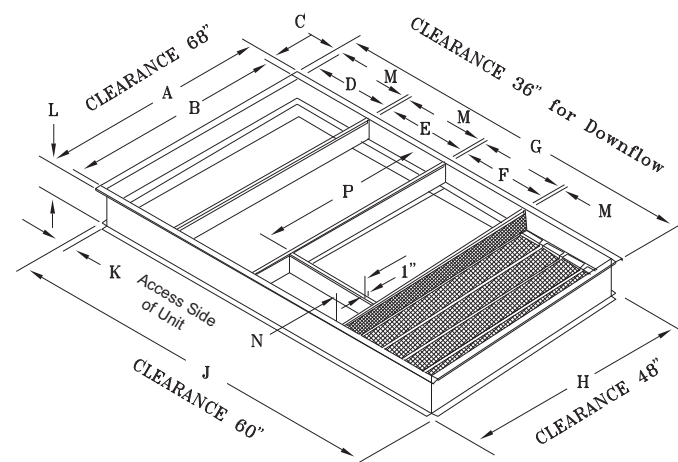

6
Table 2. Dimensional data (inches)

UNITS	A	B	C	D	E	F	G	H	J	K	L	M	N	P
BAYCURB027*	80 5/8	77	1 13/16	22 1/4	23 1/4	28 9/16	116 7/8	81	117 3/16	2	14 1/16	1	7 1/2	69 1/2

Figure 2. Center of gravity

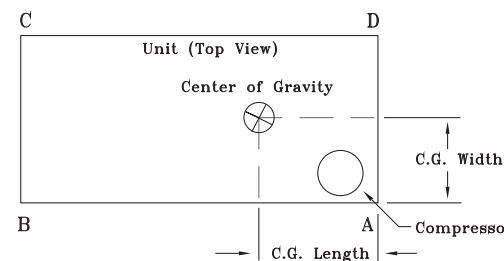

Note: Corner weights are given for information only. Unit should be supported continuously by a curb or equivalent frame support.

Table 3. Model unit and corner weights (lb) and center of gravity dimensions (in.)

Unit Model No.	Weights (lb) ^{(a), (b)}	Corner Weights ^(c)				Center of Gravity (in.)	
	Net	A	B	C	D	Length	Width
ECC180A	1850	638	477	367	367	56	35
GCC180A	2013	649	508	398	459	55	37
ECC210A	1855	637	479	369	369	56	35
GCC210A	2028	653	511	399	464	55	37
ECC240A	1860	632	484	372	372	55	37
GCC240A	2025	643	512	403	466	55	37

7
Table 3. Model unit and corner weights (lb) and center of gravity dimensions (in.) (continued)

Unit Model No.	Weights (lb) ^{(a), (b)}	Corner Weights ^(c)				Center of Gravity (in.)	
	Net	A	B	C	D	Length	Width
ECC300A	1896	644	492	379	379	55	36
GCC300A	2061	671	524	393	472	55	36

(a) Weights are approximate. Horizontal and downflow unit and corner weights may vary slightly.
(b) Weights do not include additional factory or field installed options/accessories. For option/accessory additional weights, refer to ordering system.
(c) Corner weights are given for information only.

Table 4. Curbs weight (net lbs.)

Curb	Weight
BAYCURB027*	235

Installation

Read the entire manual carefully to become familiar with the roof curb installation procedures. If the roof curb will be mounted on a new building, it can be assembled at any convenient location and installed as soon as the roof support members are in place. The curb should be placed directly on the roof support members.

Use tack welding or other suitable fastening method to secure the roof curb in place. The curb can also be mounted on a roof deck. In this case, additional nailing plates must be provided directly below the flanges of the curb to give further support, and to minimize vibration. See Figure 3 and Figure 4.

Roof Curb Assembly

- Break the bands and remove the wood holding the curb assembly together.
- Set the four perimeter pieces, (two end rails and two side rails), together to form the curb.
- Using screws provided, attach the corners by allowing the angle of the side rail to fit inside the end rail. Insert three screws in each corner (see Figure 5).

- Insert screws through the end rails and into the corner angle of the side rails.
- Mount duct flanges on the two side rails and one of the end rails. Mount with screws provided through the exterior panel and into the flange. The duct flanges should be mounted with the flange next to the rails pointing down (see Figure 6).

Important: The end of the curb with curb flange attached must be used as the return air end.

- Locate the cross support pieces (with the curb flange down) according to the dimensional drawings in Figure 1. The flanges on the cross supports must match the duct.
- Use three screws at the end of each cross support. Screws must enter from the exterior of the curb.

Note: Measure supply and return dimensions to confirm that the correct holes in the side rails are used.

- Lay the three or four insulated block-offs, (with the insulation side up), cross ways in the section of the curb that will support the compressor end of the unit. They will rest on the duct flanges.

Important: If the cross members have been located on the wrong end of the curb, the insulated block-off next to the end of the curb will not lie flat. Apply the gasket material (provided) directly to the rails and cross members as shown in Figure 7. Gasket should be cut and put together at the corners.

Note: Do not round the corners with the gasket material.

- Curb is now ready to be installed around the roof opening.

Curb Installation

- Set the curb in the proper position around the roof opening.
- The curb must be leveled to confirm proper flow of condensate from the unit. The maximum pitch of the roof curb down from the access side of the unit (See Figure 1) is 1/16 inch per foot. To check the flatness of the curb, stretch lines diagonally between opposite corners of the assembled curb. The distance between the lines (at their point of intersection) should not exceed 1/4 inch. If the lines touch, reverse them (place the top line on the bottom and the bottom line on top), and recheck the point of intersection. Shim under the curb as necessary.
- Check the curb assembly for squareness by measuring diagonally between opposite corners of the curb. The distance indicated by these measurements should be the same.
- Fasten the curb to the roof support members, or roof deck. See Figure 3 and Figure 4.
- Bring the roof material up to the curb as shown in Figure 3 and Figure 4. Place a piece of rigid insulation around the curb and fasten it (from the inside), with nails.
- Install cant strips as shown in Figure 3 of either 4-inch x 4-inch wood (cut diagonally in half), or other suitable material. With the cant strips in place, bring the roofing felts up to the top of the curb nailing strips. Push the felts up under the lip of the curb and nail them tightly into position.

Note: Any pipes or electrical conduits which extend through the roof must be flashed with a sleeve and roof flange extending a minimum of eight inches above the roof surface.

- The roof curb installation is now complete and ready for ductwork and unit installation.

Figure 3. Typical installation on new construction

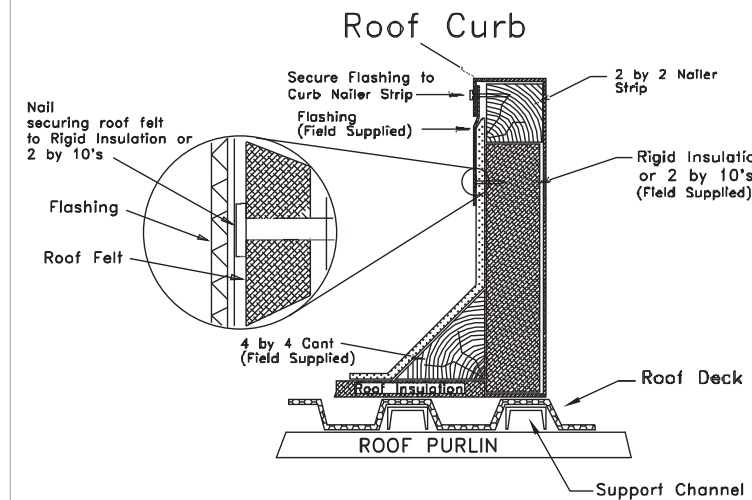

Figure 4. Typical installation on existing construction

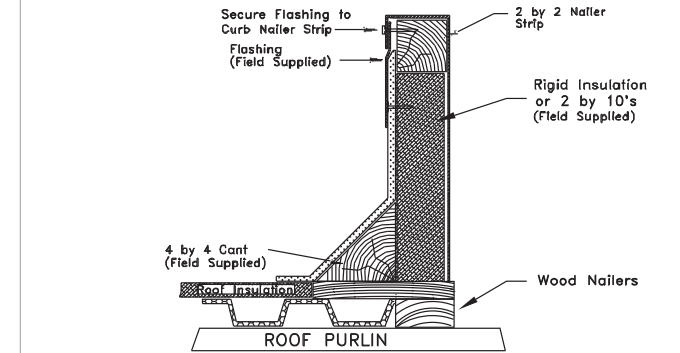

Figure 5. Curb rail assembly A

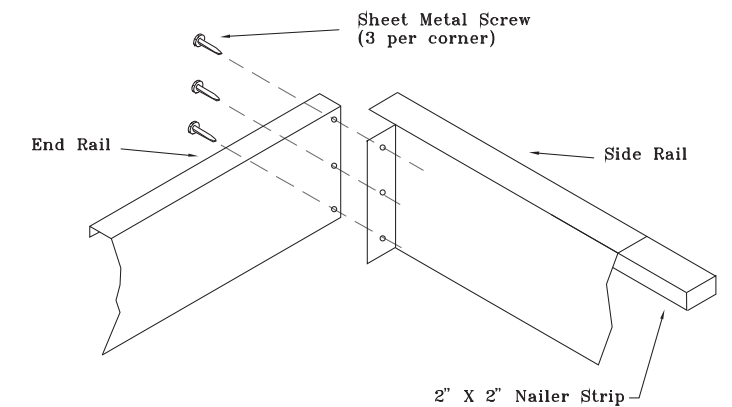

Figure 6. Curb rail assembly B

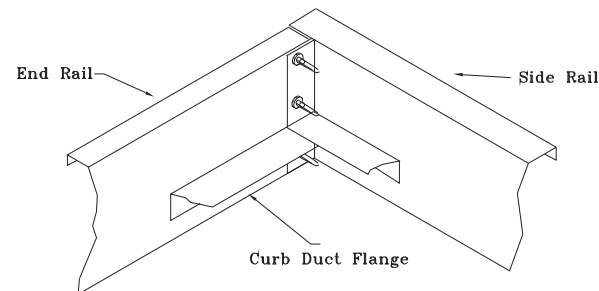
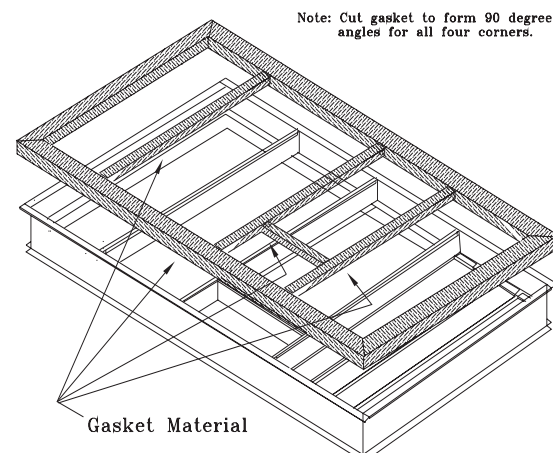

Figure 7. Installing gasket material



Supply and Return Air Ductwork

- When flexible duct is not desired, metal or fiberboard duct may be installed.
- The metal or fiberboard duct must conform to all local building codes.
- The duct must be hung from the curb flanges inside the curb walls.

Important: Duct work must be hung from the curb flanges. It must not be installed over the top edges of the curb.

- When the duct is fabricated it should be large enough to cover the openings for the return and supply sides of the unit, but the flanges must be narrow enough to slide down inside the curb.

Important: All duct work attached to the curb, must be in place and secured before the unit is set.

- To verify proper duct construction and installation, SMACNA recommendations should be closely followed.

Notes:

- All field fabricated panels used must be insulated.
- Fabricated duct flange must rest on inside of curb on flange, as shown, after installation.

Table 5. Supply and return air ductwork dimensions

UNITS	A	B	C	D	E	F	G
BAYCURB027*	73 7/16	19 5/16	66 1/2	26 5/16	1	14 1/16	7 7/16

Figure 8. Duct dimensions

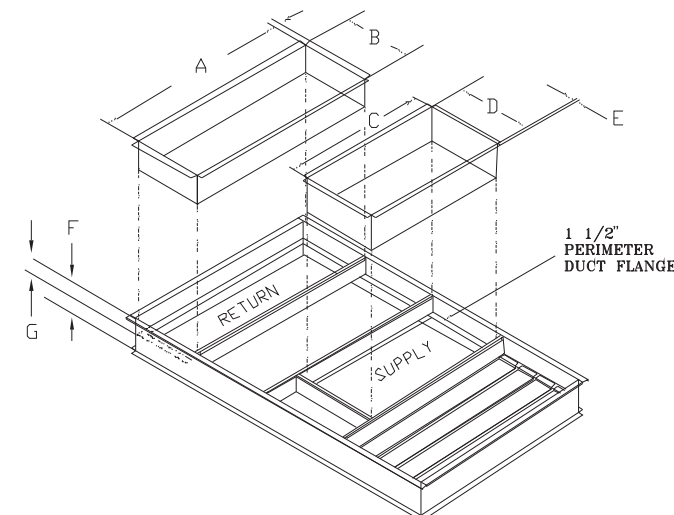

Trane and American Standard create comfortable, energy efficient indoor environments for commercial and residential applications. For more information, please visit trane.com or americanstandardair.com.

Trane and American Standard have a policy of continuous product and product data improvement and reserve the right to change design and specifications without notice. We are committed to using environmentally conscious print practices.