

Installation Instructions

Electric Heaters

Precedent™ 6 to 10 Ton Models

Model Number: **Used With:**
See General Information

SAFETY WARNING

Only qualified personnel should install and service the equipment. The installation, starting up, and servicing of heating, ventilating, and air-conditioning equipment can be hazardous and requires specific knowledge and training. Improperly installed, adjusted or altered equipment by an unqualified person could result in death or serious injury. When working on the equipment, observe all precautions in the literature and on the tags, stickers, and labels that are attached to the equipment.

September 2022

ACC-SVN67M-EN

Introduction

Read this manual thoroughly before operating or servicing this unit.

Warnings, Cautions, and Notices

Safety advisories appear throughout this manual as required. Your personal safety and the proper operation of this machine depend upon the strict observance of these precautions.

The three types of advisories are defined as follows:

⚠ WARNING Indicates a potentially hazardous situation which, if not avoided, could result in death or serious injury.

⚠ CAUTION Indicates a potentially hazardous situation which, if not avoided, could result in minor or moderate injury. It could also be used to alert against unsafe practices.

NOTICE Indicates a situation that could result in equipment or property-damage only accidents.

Important Environmental Concerns

Scientific research has shown that certain man-made chemicals can affect the earth's naturally occurring stratospheric ozone layer when released to the atmosphere. In particular, several of the identified chemicals that may affect the ozone layer are refrigerants that contain Chlorine, Fluorine and Carbon (CFCs) and those containing Hydrogen, Chlorine, Fluorine and Carbon (HCFCs). Not all refrigerants containing these compounds have the same potential impact to the environment. Trane advocates the responsible handling of all refrigerants-including industry replacements for CFCs and HCFCs such as saturated or unsaturated HFCs and HCFCs.

Important Responsible Refrigerant Practices

Trane believes that responsible refrigerant practices are important to the environment, our customers, and the air conditioning industry. All technicians who handle refrigerants must be certified according to local rules. For the USA, the Federal Clean Air Act (Section 608) sets forth the requirements for handling, reclaiming, recovering and recycling of certain refrigerants and the equipment that is used in these service procedures. In addition, some states or municipalities may have additional requirements that must also be adhered to for responsible management of refrigerants. Know the applicable laws and follow them.

⚠ WARNING

Proper Field Wiring and Grounding Required!

Failure to follow code could result in death or serious injury. All field wiring **MUST** be performed by qualified personnel. Improperly installed and grounded field wiring poses **FIRE** and **ELECTROCUTION** hazards. To avoid these hazards, you **MUST** follow requirements for field wiring installation and grounding as described in **NEC** and your local/state/national electrical codes.

⚠ WARNING

Personal Protective Equipment (PPE) Required!

Failure to wear proper PPE for the job being undertaken could result in death or serious injury. Technicians, in order to protect themselves from potential electrical, mechanical, and chemical hazards, **MUST** follow precautions in this manual and on the tags, stickers, and labels, as well as the instructions below:

- Before installing/servicing this unit, technicians **MUST** put on all PPE required for the work being undertaken (Examples; cut resistant gloves/sleeves, butyl gloves, safety glasses, hard hat/bump cap, fall protection, electrical PPE and arc flash clothing). **ALWAYS** refer to appropriate Safety Data Sheets (SDS) and OSHA guidelines for proper PPE.
- When working with or around hazardous chemicals, **ALWAYS** refer to the appropriate SDS and OSHA/GHS (Global Harmonized System of Classification and Labeling of Chemicals) guidelines for information on allowable personal exposure levels, proper respiratory protection and handling instructions.
- If there is a risk of energized electrical contact, arc, or flash, technicians **MUST** put on all PPE in accordance with OSHA, NFPA 70E, or other country-specific requirements for arc flash protection, **PRIOR** to servicing the unit. **NEVER PERFORM ANY SWITCHING, DISCONNECTING, OR VOLTAGE TESTING WITHOUT PROPER ELECTRICAL PPE AND ARC FLASH CLOTHING. ENSURE ELECTRICAL METERS AND EQUIPMENT ARE PROPERLY RATED FOR INTENDED VOLTAGE.**

⚠ WARNING

Follow EHS Policies!

Failure to follow instructions below could result in death or serious injury.

- All Trane personnel must follow the company's Environmental, Health and Safety (EHS) policies when performing work such as hot work, electrical, fall protection, lockout/tagout, refrigerant handling, etc. Where local regulations are more stringent than these policies, those regulations supersede these policies.
- Non-Trane personnel should always follow local regulations.

Copyright

This document and the information in it are the property of Trane, and may not be used or reproduced in whole or in part without written permission. Trane reserves the right to revise this publication at any time, and to make changes to its content without obligation to notify any person of such revision or change.

Trademarks

All trademarks referenced in this document are the trademarks of their respective owners.

Revision History

Updated Heater Model Number for WSC120H3 in Electrical Data chapter.

Table of Contents

General Information	5
General	7
Inspection	7
Installation	8
Electrical Data	12

General Information

Table 1. Heater information

Model Number	Used With				
BAYHTRS309 BAYHTRS318 BAYHTRS327 BAYHTRS336	TSC072H3				
BAYHTRS409	TSC072H4				
BAYHTRS418 BAYHTRS427 BAYHTRS436	TSC072H4	TSC072ED WSC072ED	WSC090ED	TSC090ED	
BAYHTRSW09 BAYHTRSW18 BAYHTRSW27 BAYHTRSW36	TSC072HW				
BAYHTRT309 BAYHTRT318 BAYHTRT327 BAYHTRT336	TSC092H3	TSC102H3			
BAYHTRT409 BAYHTRT418	TSC092H4	TSC102H4			
BAYHTRT427 BAYHTRT436	TSC092H4 TSC120ED	TSC102H4	TSC102ED WSC120ED		
BAYHTRT454	TSC120ED		WSC120ED		
BAYHTRTW18 BAYHTRTW27 BAYHTRTW36	TSC092EW	TSC102EW			
BAYHTRA309	THC074F3, TZC072F3 WSC090H3(a)	THC092F3, TZC090F3 WSC102H3(a)	WSC092H3(a), WHC074H3, WHC092H3, WHC102H3	THC102F3, TZC102F3	TSC092H3, TSC102H3
BAYHTRA318	THC074F3 WSC090H3(a)	THC092F3 WSC102H3(a)	WSC092H3(a), WHC074H3, WHC092H3, WHC102H3	THC102F3	WSC120H3
BAYHTRA327	TSC120H3 WSC090H3(a)	THC074F3, TZC072F3 WSC102H3(a), WSC120H3	THC092F3 TZC090F3	THC102F3, TZC102F3 TSC092H3, TSC102H3	WSC092H3(a), WHC074H3, WHC092H3, WHC102H3
BAYHTRZ318(a)	TZC072F3 TZC102F3	TZC090F3 TSC102H3	TSC092H3 TSC120H3		
BAYHTRA336	THC074F3 WSC090H3(a)	THC092F3 WSC102H3(a)	THC102F3 WSC120H3	WSC092H3(a), WHC074H3, WHC092H3, WHC102H3	
BAYHTRZ336(a)	TZC072F3 TSC102H3	TZC090F3	TSC092H3	TZC102F3	
BAYHTRA354	TSC120H3	WSC120H3			
BAYHTRA409	THC074F4, THC092F4	TSC092H4, TSC102H4	WSC090H4(a)	WSC102H4(a)	WSC092H4(a), WHC074H4, WHC092H4, WHC102H4
BAYHTRZ409	TZC072F4	TZC090F4	TZC102F4		
BAYHTRA418	TSC120H4, TSC092H4 TSC102H4	THC074F4, TZC072F4 WSC090H4(a)	THC092F4, TZC090F4 WSC102H4(a)	THC102F4, TZC102F4 WSC120H4	WSC092H4(a), WHC074H4, WHC092H4, WHC102H4
BAYHTRA427	TSC120H4 TSC092H4, TSC102H4	THC074F4, TZC072F4 WSC090H4(a)	THC092F4, TZC090F4 WSC102H4(a)	THC102F4, TZC102F4 WSC120H4	WSC092H4(a), WHC074H4, WHC092H4, WHC102H4

General Information

Table 1. Heater information (continued)

Model Number	Used With				
BAYHTRA436	TSC120H4, TSC092H4 TSC102H4	THC074F4, TZC072F4 WSC090H4(a)	THC092F4, TZC090F4 WSC102H4(a)	THC102F4, TZC102F4 WSC120H4	WSC092H4(a), WHC074H4, WHC092H4, WHC102H4
BAYHTRA454	TSC120H4	WSC120H4			
BAYHTRZ454A	TZC120H4				
BAYHTRAW18	TSC120HW TSC102HQW	TZC072FW, TSC092HW, WSC090HW(a)	THC092FW, TZC090FW WSC102HW(a)	THC102FW, TZC102FW WSC120HW	WSC092HW(a), WHC074HW, WHC092HW, WHC102HW
BAYHTRAW27	WSC090HW(a)	WSC102HW(a)	WSC120HW	WSC092HW(a), WHC074HW, WHC092HW, WHC102HW	
BAYHTRAW36	TSC120HW, TSC092HW, TSC102HW	TZC072FW WSC090HW(a)	THC092FW, TZC090FW WSC102HW(a)	THC102FW, TZC102FW WSC120HW	WSC092HW(a), WHC074HW, WHC092HW, WHC102HW
BAYHTRAW54	TSC120HW	WSC120HW			
BAYHTRB318	WHC120H3				
BAYHTRB327	WHC120H3				
BAYHTRB336	WHC120H3				
BAYHTRB354	WHC120H3				
BAYHTRB418	WHC120H4				
BAYHTRB427	WHC120H4				
BAYHTRB436	WHC120H4				
BAYHTRB454	WHC120H4				
BAYHTRBW18	TZC120FW	WHC120HW			
BAYHTRBW36	WHC120HW				
BAYHTRBW54	WHC120HW				
BAYHTRD318	THC120E3	TZC120F3			
BAYHTRD327	THC120E3	TZC120F3			
BAYHTRD336	THC120E3				
BAYHTRZ337A	TZC120F3				
BAYHTRD354	THC120E3				
BAYHTRZ354A	TZC120F3				
BAYHTRD418	THC120E4	TZC120F4			
BAYHTRD427	THC120E4	TZC120F4			
BAYHTRD436	THC120E4				
BAYHTRZ436A	TZC120F4				
BAYHTRD454	THC120E4				
BAYHTRZ454A	TZC120F4				
BAYHTRU309	THC072F3	WSC090H3	WSC092H3	WSC102H3	
BAYHTRU318	THC072F3	WSC090H3	WSC092H3	WSC102H3	
BAYHTRU327	THC072F3	WSC090H3	WSC092H3	WSC102H3	
BAYHTRU336	THC072F3	WSC090H3	WSC092H3	WSC102H3	
BAYHTRU409	THC072F4	WSC090H4	WSC092H4	WSC102H4	
BAYHTRU418	THC072F4	WSC090H4	WSC092H4	WSC102H4	
BAYHTRU427	THC072F4	WSC090H4	WSC092H4	WSC102H4	
BAYHTRU436	THC072F4	WSC090H4	WSC092H4	WSC102H4	
BAYHTRUW18	THC072FW	WSC090HW	WSC092HW	WSC102HW	
BAYHTRUW27	THC072FW	WSC090HW	WSC092HW	WSC102HW	
BAYHTRUW36	THC072FW	WSC090HW	WSC092HW	WSC102HW	

Table 1. Heater information (continued)

Model Number	Used With			
BAYHTRW309	TSC090H3	WSC072H3		
BAYHTRW318	TSC090H3	WSC072H3		
BAYHTRW327	TSC090H3	WSC072H3		
BAYHTRW336	TSC090H3	WSC072H3		
BAYHTRW409	TSC090H4	WSC072H4		
BAYHTRW418	TSC090H4	WSC072H4		
BAYHTRW427	TSC090H4	WSC072H4		
BAYHTRW436	TSC090H4	WSC072H4		
BAYHTRWW18	TSC090HW	WSC072HW		
BAYHTRWW27	TSC090HW	WSC072HW		
BAYHTRWW36	TSC090HW	WSC072HW		

(a) These kits to be used with Title 24/SZVAV models.

General

ALL phases of this installation must comply with NATIONAL, STATE AND LOCAL CODES. Installer must mark unit nameplate with heater information per instructions on nameplate.

Note: If digit 9 in the unit model number equals “E” (electromechanical control), accessory relay BAY24X042 is required if the thermostat does not energize the fan circuit in the heating mode. See Figure 1 for wiring information.

Figure 1. Electromechanical wiring diagram

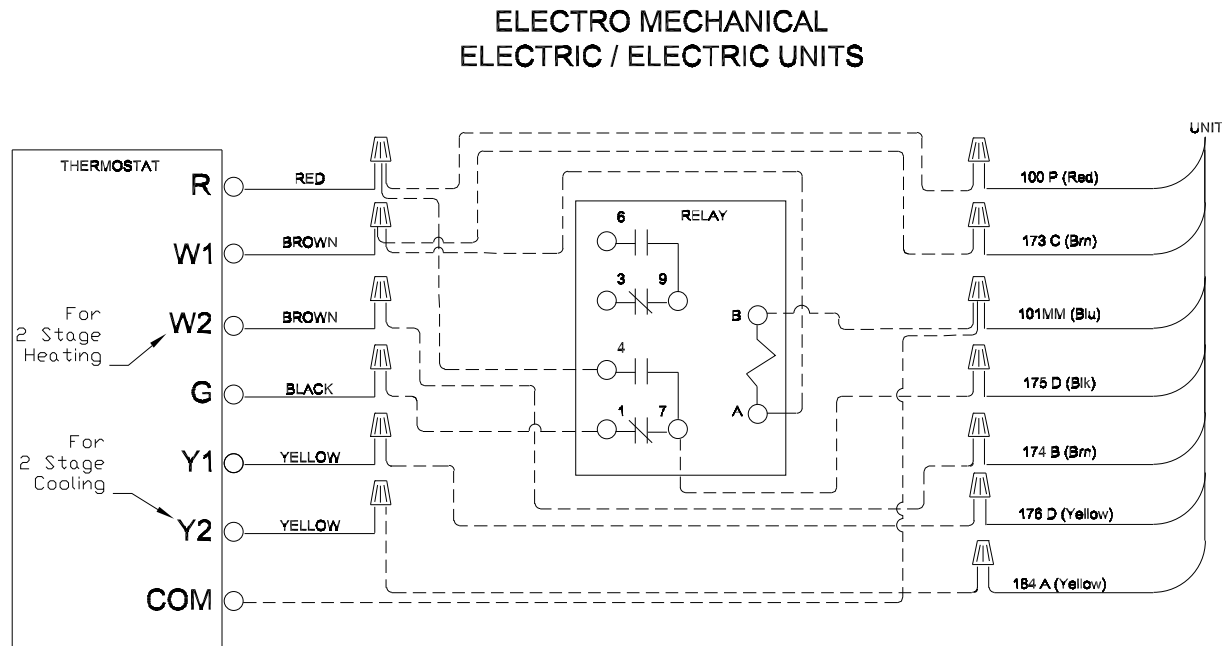

Inspection

1. Unpack all components of the kit.
2. Check carefully for any shipping damage. If any damage is found it must be reported immediately and a claim made against the transportation company.
3. Check the heater nameplate model number and compare with the electrical data tables. Ensure that the available power supply and unit's model number complies with the particular heater being used.

Installation

⚠ WARNING

Hazardous Voltage w/Capacitors!

Failure to disconnect power and discharge capacitors before servicing could result in death or serious injury. Disconnect all electric power, including remote disconnects and discharge all motor start/run capacitors before servicing. Follow proper lockout/tagout procedures to ensure the power cannot be inadvertently energized. For variable frequency drives or other energy storing components provided by Trane or others, refer to the appropriate manufacturer's literature for allowable waiting periods for discharge of capacitors. Verify with a CAT III or IV voltmeter rated per NFPA 70E that all capacitors have discharged.

⚠ WARNING

Fire Hazard!

On BAYHTRA, BAYHTRB, BAYHTRD, BAYHTRU, and BAYHTRW heater kits, failure to allow a one inch clearance from the supply ductwork to any combustible materials could cause the combustible materials to catch on fire which could result in death, serious injury, or property damage.

1. Remove heater compartment access panel and unit control box access panel. See [Figure 2](#).

Figure 2. Control covers and access panels

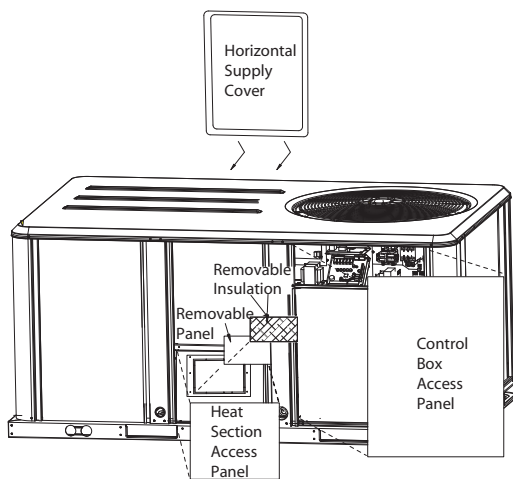

Note: On downflow units with or without duct work installed or horizontal units without ductwork installed, remove horizontal supply cover from the rear of the heater compartment.

2. Remove insulation to expose perimeter of removable panel in the vestibule panel. See [Figure 2](#).
3. Clip or cut the retaining tabs around the perimeter of the removable panel.

4. Remove the panel.
5. Check the opening in the vestibule panel. Remove any metal burrs or slivers that could damage or pinch the heater elements resulting in a short circuit when elements are installed in the opening.

Note: Locator tabs on the vestibule panel support the electric heat assembly and secure the inward edge of the electric heat accessory control panel. Slits in the insulation should allow the tabs to protrude through the insulation and be visible. However, it may be necessary to work the insulation back from the tabs and slightly bend the tabs outward if difficulty is encountered engaging the electric heater panel or the electric heat accessory control panel. See [Figure 3](#).

Figure 3. Electric heater element panel

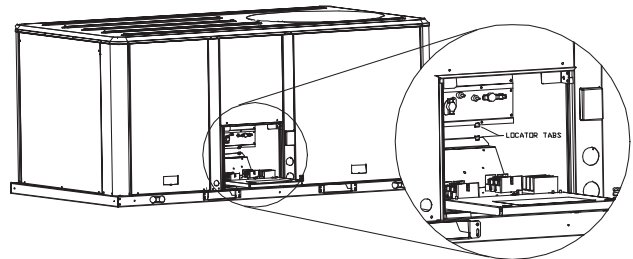

6. The electric heater element assembly has "BOTTOM" stamped in the mounting panel to identify the proper position for mounting.
7. Refer to [Table 2](#). If the unit/heater combination being installed is the same as any in this table **and the application is for horizontal airflow**, the limit control TCO-A must be replaced with the extra limit control shipped with the heater. Replace TCO-A following the instructions in [Step 8](#) and [Step 9](#). If the unit/heater combination being installed does not correspond to any in this table or if the application is for downflow airflow, skip steps 8 and 9 and go on to [Step 10](#).

Table 2. TCO-A replaced for horizontal duct configuration

Unit Model Number	Electric Heater Model Number	TCO-A location
TSC120H4, WSC120H4	BAYHTRA454	Right
TSC120HW, TZC072FW, TZC090FW, and TZC102FW	BAYHTRAW18, BAYHTRAW36, W54	Right
TZC120FW, WHC120HW	BAYHTRBW18A, BAYHTRZW36A, BAYHTRZW54A, BAYHTRBW36, W54	Right
THC092F4, THC074F4, THC102F4, TSC120H4, TZC072F4, TZC090F4, and TZC102F, TZ102F4	BAYHTRA427, BAYHTRA436, BAYHTRZ409, BAYHTRA418	Right
THC072E4, WSC090H4	BAYHTRU427, 436	Center
WSC090HW	BAYHTRUW27, W36	Center
WSC072H3	BAYHTRW327, 336	Center
TSC090E4, WSC072H4	BAYHTRW427, 436	Center
TSC090EW, WSC072HW	BAYHTRWW27, W36	Center
WSC092H3, WSC102H3	BAYHTRU336	Center
WSC092H4, WSC102H4	BAYHTRU436	Center

8. TCO-A is the limit control located in the center or right part of the heater mounting plate that is located on the bottom of the two heater element assemblies. See Figure 4. To replace this device, first remove the two wires connected to the terminals. Next, remove the two screws which secure it to the heater element mounting plate. Once TCO-A has been removed from the heater element mounting plate, discard this device.

Figure 4.

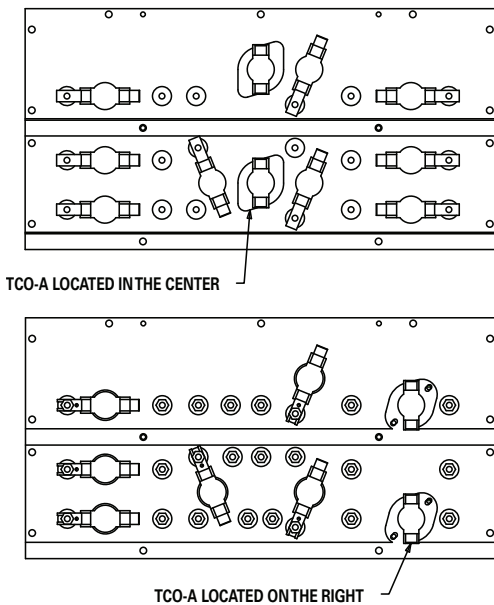

9. Obtain the replacement TCO-A which is secured with a wire tie near the unit/heater terminal block located on the electric heater control panel. Attach it to the heater element

mounting plate with the two screws that were removed in step 8. Connect the two wires that were un-hooked in step 8 to the terminals on the new TCO-A. Refer to the heater package wiring diagram to assure that the wiring is connected properly.

Note: The back of the electric heater element assembly is supported by a factory installed Electric Heat Support Rod Hanger or other sheet metal device in the unit.

10. Tilt the back of the electric heater element assembly slightly upward as it is positioned in the opening to engage the support rod with the support rod hanger. The BAYHTRA, BAYHTRB, and BAYHTRD models will have a guide rod and a support bracket to help with the installation. See Figure 5. Be very careful to avoid dragging the heater element on the edges of the opening in vestibule panel, as this could damage or pinch the heater elements resulting in a short circuit. Engage the bottom edge of heater element panel with the two locator tabs. See Figure 3. BAYHTRB and BAYHTRD kits will have 4 locator tabs along the top, a filler panel to be placed below the heater, and 12 screws to attach the assembly in place. See Figure 6.

Figure 5.

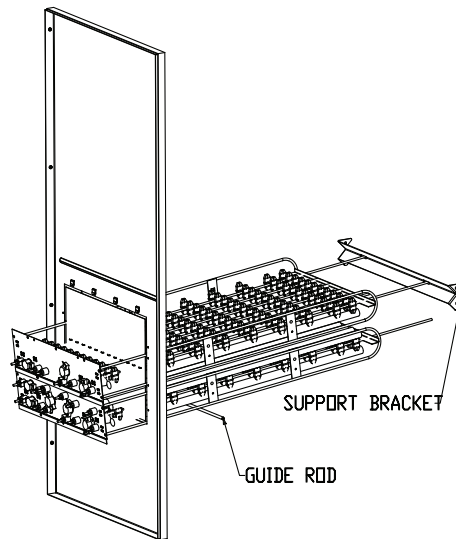

Installation

Figure 6.

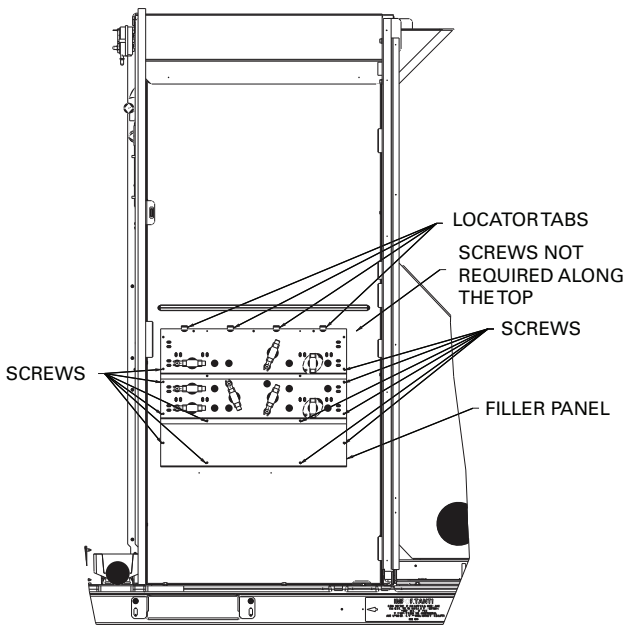

11. Secure the electric heater element assembly with the necessary amount of screws.
12. Slide the electric heater control panel/access door assembly inward until the rear edge engages with retaining clips. See Figure 3. For the BAYHTRS, BAYHTRT, BAYHTRU, and BAYHTRW kits, secure the outer edge with 2 screws. The BAYHTRA, BAYHTRB, and BAYHTRD kits will secure the control panel with screws at the top against the vestibule panel and against the indoor divider panel. See Figure 7.

Figure 7.

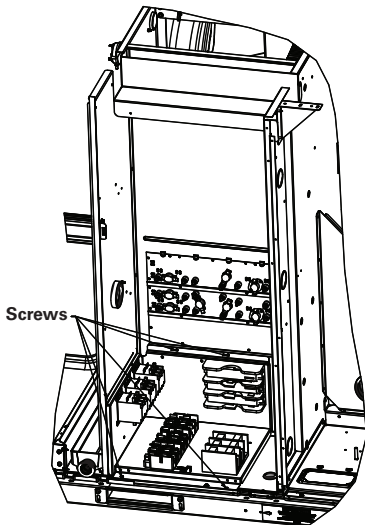

13. To install the hinged door stops, loosen one existing screw from the upper left side of the electric heater compartment opening. Position each door stop with outer tab flush

against center post and secure each door stop with 1 or 2 screws. See zoom view in Figure 8 or Figure 9.

Figure 8. Single point power

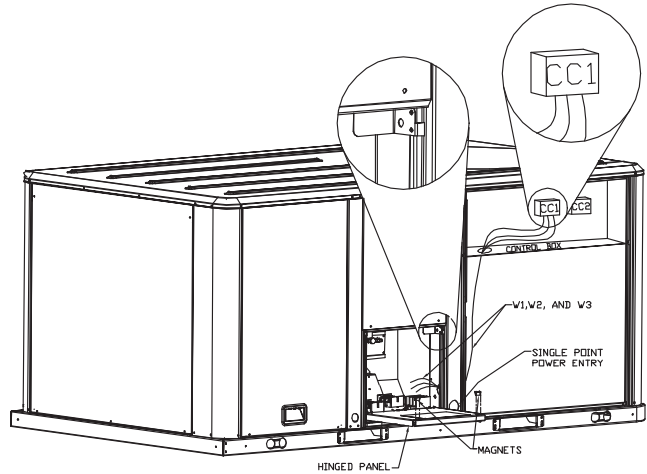
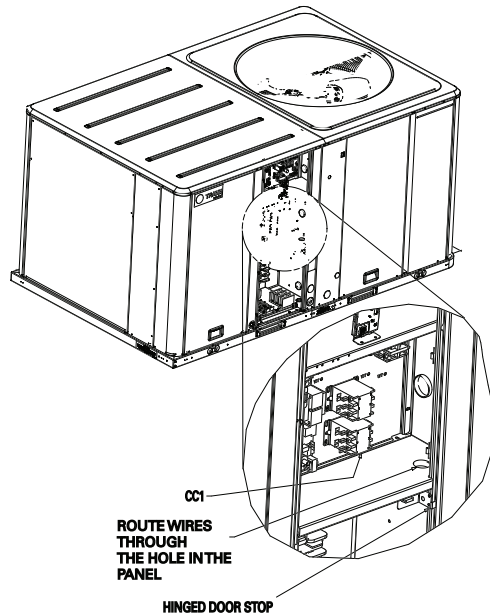

Figure 9.



14. Remove the wire nuts from W1, W2 and W3.
15. For models with the control box in the outdoor section, route the wires through the wire access opening in the divider panel, then up to the unit control box entering through the bottom wire access opening on the left side. See Figure 8. For models with the control box above the heat exchanger section, route the wires through the hole in the panel separating the heater compartment and the control box compartment. See Figure 9. Secure wires to the existing harness.

16. In the unit control box, route the wires along the existing harness to contactor CC1. Secure wires to existing harness.
17. Locate the low voltage wire harness with polarized plug in the electric heater section compartment. Remove the factory installed jumper. Connect the low voltage polarized plug from the unit to the polarized plug on the electric heater assembly.
18. Wire the heater element assembly to the electric heater control panel according to the wiring diagram attached to the electric heater control panel door.
19. Secure the green ground wire from the electric heat control panel to the right hand wall of electric heater compartment with star washer and #10 grounding screw.
20. Wire W1, W2 and W3 wires to CC1 according to the wiring diagram attached to the unit control panel door.
21. Route single point power entry wires through the front access opening of the support panel adjacent to the electric heater section compartment. Using good installation practices, provide strain relief for high voltage wires where necessary. See [Figure 8](#) or [Figure 9](#).

proximity to supporting structure or cabinet. At least 1/4 inch clearance is required around electric heater coils.

Important: *Be sure to check tightness of all terminal connections, clamps, screws, etc., as these may have become loose in shipment. Retighten all electrical connections after equipment has been in operation and components have reached operating temperature.*

23. Install the magnets into the door as seen in [Figure 8](#) or [Figure 9](#). Magnets should lock into place once installed. Close electric heater control panel access door, replace heat section access panel and unit control box access panel. Replace horizontal supply cover. Be careful when replacing cover and make sure gasketing is not torn or missing. Gasket must make water tight seal.
24. Scratch out the square on unit nameplate showing heater model installed in unit.

NOTICE

Use Copper Conductors Only!

Unit terminals are not designed to accept other types of conductors. Failure to use copper conductors could result in equipment damage.

⚠ WARNING

Proper Field Wiring and Grounding Required!

Failure to follow code could result in death or serious injury. All field wiring **MUST** be performed by qualified personnel. Improperly installed and grounded field wiring poses **FIRE** and **ELECTROCUTION** hazards. To avoid these hazards, you **MUST** follow requirements for field wiring installation and grounding as described in **NEC** and your local/state/national electrical codes.

22. Wire according to the wiring diagram attached to the electric heater control panel door. Ground unit at grounding lug provided on electric heater control panel assembly.

Important: *After heater is installed and before applying power, verify that heating elements are not damaged or pinched and that heating elements are not short circuited to each other or to the heater frame or equipment cabinet by doing the following: Test every heater element with ohmmeter and verify that heater element terminals are electrically isolated from cabinet and ground (infinite resistance). On downflow units with or without duct work installed or horizontal units without ductwork installed, remove horizontal supply cover and carefully inspect elements after installation for damage or*

Electrical Data

Table 3. Air temperature rise (60 Hz)^(a)

		6 Ton		7.5 Ton		7.5 Ton		8.5 Ton		10 Ton	
		2000 cfm ^{(b),(c)} (2)		3000 cfm		3000 cfm		3400 cfm		4000 cfm ^{(d),(e)}	
Nominal kW Input	No. of Capacity Stages	T*C072E3 T*C072E4 T*C072EW THC074F3 THC074F4 TZC072F3, TZC072F4, and TZC072FW	WSC072H3 WSC072H4 WSC072HW	TSC090E3 TSC090E4 TSC090EW	WSC092H3 WSC092H4 WSC092HW	TSC092E3 TSC092E4 TSC092EW THC092F3,4 TZC090F3, TZC090F4, and TZC090FW	WSC090H3 WSC090H4 WSC090HW	T*C102E3 T*C102E4 THC102F3,4 TSC102EW TZC102F3, TZC102F4, and TZC102FW	WSC102H3W SC102H4WS C102HW	THC120E3 THC120E4 TSC120H3 TSC120H4 TSC120HW TZC120F3, TZC120F4, and TZC120FW	WSC120H3 WSC120H4 WSC120HW
9.0	1	14.2	14.2	9.5	9.5	9.5	9.5	8.4	8.4	—	—
11.3	1	14.9	14.9	11.9	11.9	—	—	—	—	—	—
16.9	2	22.3	22.3	17.8	17.8	15.7	15.7	15.7	15.7	13.4	13.4
18.0	1	28.5	28.5	19.0	19.0	19.0	19.0	16.7	16.7	14.2	14.2
22.6	2	29.8	29.8	23.8	23.8			21.0	21.0	7.9	17.9
27.0	2	42.7	42.7	28.5	28.5	28.5	28.5	25.1	25.1	21.3	21.3
33.80	2	—	—	—	—	—	—	—	—	26.7	26.7
36.00	2	56.9	56.9	37.9	37.9	37.9	37.9	33.5	33.5	28.5	28.5
54.00	2	—	—	—	—	—	—	—	—	42.7	42.7

- (a) The air temperature rise (F) across the heaters is: (Heater kW x 3414)/(1.08 x cfm).
- (b) The minimum allowable airflow for TSC072E, TZC072F with a 36.0 kW heater is 2200 cfm.
- (c) The minimum allowable airflow for WSC072H with a 36.0 kW heater is 2450 cfm.
- (d) The minimum allowable airflow for a TSC120EF, TZC120F and THC120E with a 54 kW heater is 3400 cfm.
- (e) The minimum allowable airflow for a WSC120 with a 54 kW heater is 4000 cfm.

Table 4. Unit wiring with electric heat (single point connection) - standard efficiency

Tons	Unit Model Number	Heater Model Number	Heater kW Rating	Control Stages	Standard Indoor Fan Motor ^(a)		Oversized Indoor Fan Motor ^(b)		Optional EBM Fan Motor	
					MCA	Max Fuse Size or Max Circuit Breaker	MCA	Max Fuse Size or Max Circuit Breaker	MCA	Max Fuse Size or Max Circuit Breaker
208/230 Volts Three Phase										
6	TSC072H3	BAYHTRS309*	6.8/9.0	1	35/35	50/50	38/38	50/50	—	—
6	TSC072H3	BAYHTRS318*	13.5/18.0	1	53/60	60/60	56/64	60/70	—	—
6	TSC072H3	BAYHTRS327*	20.3/27.0	2	76/87	80/90	80/91	80/100	—	—
6	TSC072H3	BAYHTRS336*	27.0/36.0	2	100/114	110/125	103/118	110/125	—	—
7.5	TSC090H3	BAYHTRW309*	6.8/9.0	1	38/38	60/60	44/44	60/60	—	—
7.5	TSC090H3	BAYHTRW318*	13.5/18.0	1	53/60	60/60	60/67	60/70	—	—
7.5	TSC090H3	BAYHTRW327*	20.3/27.0	2	76/87	80/90	84/94	90/100	—	—
7.5	TSC090H3	BAYHTRW336*	27.0/36.0	2	99/114	100/125	107/122	110/125	—	—
7.5(c)	TSC092H3	BAYHTRT309* BAYHTRA309(d)	6.8/9.0	1	39/39	50/50	45/45	50/50	43/43	50/50
7.5(c)	TSC092H3	BAYHTRT318* BAYHTRZ318(d)	13.5/18.0	1	53/60	60/60	60/67	60/70	58/65	60/70
7.5(c)	TSC092H3	BAYHTRT327* BAYHTRA327(d)	20.3/27.0	2	76/87	80/90	84/94	90/100	81/92	90/100
7.5(c)	TSC092H3	BAYHTRT336* BAYHTRZ336(d)	27.0/36.0	2	99/114	100/125	107/122	110/125	104/119	110/125
8.5	TSC102H3	BAYHTRT309* BAYHTRA309(d)	6.8/9.0	1	44/44	50/50	47/47	60/60	45/45	60/60

Table 4. Unit wiring with electric heat (single point connection) - standard efficiency (continued)

Tons	Unit Model Number	Heater Model Number	Heater kW Rating	Control Stages	Standard Indoor Fan Motor ^(a)		Oversized Indoor Fan Motor ^(b)		Optional EBM Fan Motor	
					MCA	Max Fuse Size or Max Circuit Breaker	MCA	Max Fuse Size or Max Circuit Breaker	MCA	Max Fuse Size or Max Circuit Breaker
8.5	TSC102H3	BAYHTRT318* BAYHTRZ318(d)	13.5/18.0	1	56/64	60/70	60/67	60/70	58/65	60/70
8.5	TSC102H3	BAYHTRT327* BAYHTRA327(d)	20.3/27.0	2	80/91	80/100	84/94	90/100	81/92	90/100
8.5	TSC102H3	BAYHTRT336* BAYHTRZ336(d)	27.0/36.0	2	103/118	110/125	107/122	110/125	104/119	110/125
10	TSC120H3	BAYHTRZ318*	13.5/18.0	1	58/65	60/70	—/—	—/—	—	—
10	TSC120H3	BAYHTRA327*	20.3/27.0	2	81/92	90/100	—/—	—/—	—	—
10	TSC120H3	BAYHTRZ336*	27.0/36.0	2	104/119	110/125	—/—	—/—	—	—
10	TSC120H3	BAYHTRA354*	40.6/54.0	2	151/141	175/175	—/—	—/—	—	—
460 Volts Three Phase										
6	TSC072H4	BAYHTRS409*	9	1	17	25	19	25	—	—
6	TSC072H4	BAYHTRS418*	18	1	31	35	32	35	—	—
6	TSC072H4	BAYHTRS427*	27	2	44	45	46	50	—	—
6	TSC072H4	BAYHTRS436*	36	2	58	60	60	60	—	—
7.5	TSC090H4	BAYHTRW409*	9	1	19	30	22	30	—	—
7.5	TSC090H4	BAYHTRW418*	18	1	31	35	34	35	—	—
7.5	TSC090H4	BAYHTRW427*	27	2	44	45	48	50	—	—
7.5	TSC090H4	BAYHTRW436*	36	2	58	60	61	70	—	—
7.5(c)	TSC092H4	BAYHTRT409* BAYHTRA409(d)	9	1	18	20	21	25	20	25
7.5(c)	TSC092H4	BAYHTRT418* BAYHTRA418(d)	18	1	31	35	34	35	33	35
7.5(c)	TSC092H4	BAYHTRT427* BAYHTRA427(d)	27	2	44	45	48	50	47	50
7.5(c)	TSC092H4	BAYHTRT436* BAYHTRA436(d)	36	2	58	60	61	70	60	60
8.5	TSC102H4	BAYHTRT409* BAYHTRA409(d)	9	1	21	25	23	25	22	25
8.5	TSC102H4	BAYHTRT418* BAYHTRA418(d)	18	1	32	35	34	35	33	35
8.5	TSC102H4	BAYHTRT427* BAYHTRA427(d)	27	2	46	50	48	50	47	50
8.5	TSC102H4	BAYHTRT436* BAYHTRA436(d)	36	2	60	60	61	70	60	60
10	TSC120H4	BAYHTRA418*	18	1	33	35	—	—	—	—
10	TSC120H4	BAYHTRA427*	27	2	47	50	—	—	—	—
10	TSC120H4	BAYHTRA436*	36	2	60	60	—	—	—	—
10	TSC120H4	BAYHTRA454*	54	2	71	90	—	—	—	—
575 Volts Three Phase										
6	TSC072HW	BAYHTRSW18*	18	1	25	25	26	30	—	—
6	TSC072HW	BAYHTRSW27*	27	2	36	40	37	40	—	—
6	TSC072HW	BAYHTRSW36*	36	2	47	50	48	50	—	—
7.5	TSC090HW	BAYHTRWW18*	18	1	25	25	27	30	—	—
7.5	TSC090HW	BAYHTRWW27*	27	2	36	40	38	40	—	—
7.5	TSC090HW	BAYHTRWW36*	36	2	47	50	49	50	—	—

Electrical Data

Table 4. Unit wiring with electric heat (single point connection) - standard efficiency (continued)

Tons	Unit Model Number	Heater Model Number	Heater kW Rating	Control Stages	Standard Indoor Fan Motor ^(a)		Oversized Indoor Fan Motor ^(b)		Optional EBM Fan Motor	
					MCA	Max Fuse Size or Max Circuit Breaker	MCA	Max Fuse Size or Max Circuit Breaker	MCA	Max Fuse Size or Max Circuit Breaker
7.5(c)	TSC092HW	BAYHTRTW18* BAYHTRAW18(d)	18	1	25	25	27	30	32	35
7.5(c)	TSC092HW	BAYHTRTW27* (No kit for 27kW)(d)	27	2	36	40	38	40	43	45
7.5(c)	TSC092HW	BAYHTRTW36* BAYHTRAW36(d)	36	2	47	50	49	50	54	60
8.5	TSC102HW	BAYHTRTW18* BAYHTRAW18(d)	18	1	26	30	27	30	32	35
8.5	TSC102HW	BAYHTRTW27* (No kit for 27kW)(d)	27	2	37	40	38	40	43	45
8.5	TSC102HW	BAYHTRTW36* BAYHTRAW36(d)	36	2	48	50	49	50	54	60
10	TSC120HW	BAYHTRAW18*	18	1	32	35	—	—	—	—
10	TSC120HW	BAYHTRAW36*	36	2	54	60	—	—	—	—
10	TSC120HW	BAYHTRAW54*	24	2	63	70	—	—	—	—

- (a) The standard motor for 3-phase (6 to 8.5 ton models) is a belt drive motor.
 (b) The oversized motor for 3-phase (6 to 8.5 ton models) is a belt drive motor.
 (c) Dual refrigeration system.
 (d) Used with Title 24/SZVAV models.

Table 5. Unit wiring with electric heat (single point connection) - standard efficiency

Tons	Unit Model Number	Heater Model Number	Heater kW Rating	Control Stages	Standard Indoor Fan Motor ^(a)		Oversized Indoor fan Motor		Optional EBM Fan Motor	
					MCA	Max Fuse Size or Max Circuit Breaker	MCA	Max Fuse Size or Max Circuit Breaker	MCA	Max Fuse Size or Max Circuit Breaker
208/230 Volts Three Phase										
6	WSC072H3	BAYHTRW309*	6.8/9.0	1	59/62	70/70	62/65	70/80	—/—	—/—
6	WSC072H3	BAYHTRW318*	13.5/18.0	1	82/89	90/100	85/92	90/100	—/—	—/—
6	WSC072H3	BAYHTRSW27*	20.3/27.0	2	106/116	110/125	108/119	110/125	—/—	—/—
6	WSC072H3	BAYHTRW336*	27.0/36.0	2	129/142	150/150	132/146	150/150	—/—	—/—
7.5	WSC090H3	BAYHTRU309*	6.8/9.0	1	59/62	70/80	65/68	80/80	—/—	—/—
7.5	WSC090H3	BAYHTRU318*	13.5/18.0	1	82/89	90/100	88/95	100/100	—/—	—/—
7.5	WSC090H3	BAYHTRU327*	20.3/27.0	2	105/116	110/125	112/122	125/125	—/—	—/—
7.5	WSC090H3	BAYHTRU336*	27.0/36.0	2	129/143	150/150	135/149	150/150	—/—	—/—
7.5	WSC092H3	BAYHTRU309*, BAYHTRA309*	6.8/9.0	1	63/67	80/80	69/73	90/90	67/71	80/90
7.5	WSC092H3	BAYHTRU318*, BAYHTRA318*	13.5/18.0	1	87/94	100/100	93/100	100/110	91/98	100/110
7.5	WSC092H3	BAYHTRU327*, BAYHTRA327*	20.3/27.0	2	110/121	110/125	116/127	125/150	114/125	125/125
7.5	WSC092H3	BAYHTRU336*, BAYHTRA336*	27.0/36.0	2	134/148	150/150	140/154	150/175	138/152	150/175
8.5	WSC102H3	BAYHTRU309*, BAYHTRA309*	6.8/9.0	1	68/72	90/90	71/75	90/90	69/73	90/90
8.5	WSC102H3	BAYHTRU318*, BAYHTRA318*	13.5/18.0	1	92/99	100/110	95/102	110/110	93/100	110/110
8.5	WSC102H3	BAYHTRU327*, BAYHTRA327*	20.3/27.0	2	115/126	125/150	118/129	125/150	116/127	125/150

Table 5. Unit wiring with electric heat (single point connection) - standard efficiency (continued)

Tons	Unit Model Number	Heater Model Number	Heater kW Rating	Control Stages	Standard Indoor Fan Motor ^(a)		Oversized Indoor fan Motor		Optional EBM Fan Motor	
					MCA	Max Fuse Size or Max Circuit Breaker	MCA	Max Fuse Size or Max Circuit Breaker	MCA	Max Fuse Size or Max Circuit Breaker
8.5	WSC102H3	BAYHTRU336*, BAYHTRA336*	27.0/36.0	2	138/153	150/175	142/156	150/175	139/154	150/175
10	WSC120H3	BAYHTRA318*	13.5/18.0	1	101/108	110/125	—/—	—/—	—/—	—/—
10	WSC120H3	BAYHTRA327*	20.3/27.0	2	124/135	125/150	—/—	—/—	—/—	—/—
10	WSC120H3	BAYHTRA336*	27.0/36.0	2	147/162	150/175	—/—	—/—	—/—	—/—
10	WSC120H3	BAYHTRA354*	40.6/54.0	2	194/184	200/200	—/—	—/—	—/—	—/—
460 Volts Three Phase										
6	WSC072H4	BAYHTRW409*	9.0	1	30	35	32	35	—	—
6	WSC072H4	BAYHTRW418*	18.0	1	44	45	45	50	—	—
6	WSC072H4	BAYHTRW427*	27.0	2	57	60	59	60	—	—
6	WSC072H4	BAYHTRW436*	36.0	2	71	80	72	80	—	—
7.5	WSC090H4	BAYHTRU409*	9.0	1	31	35	34	40	—	—
7.5	WSC090H4	BAYHTRU418*	18.0	1	44	50	47	50	—	—
7.5	WSC090H4	BAYHTRU427*	27.0	2	58	60	61	70	—	—
7.5	WSC090H4	BAYHTRU436*	36.0	2	71	80	74	80	—	—
7.5	WSC092H4	BAYHTRU409*, BAYHTRA409*	9.0	1	32	40	35	40	34	40
7.5	WSC092H4	BAYHTRU418*, BAYHTRA418*	18.0	1	45	50	48	50	47	50
7.5	WSC092H4	BAYHTRU427*, BAYHTRA427*	27.0	2	59	60	62	70	61	70
7.5	WSC092H4	BAYHTRU436*, BAYHTRA436*	36.0	2	72	80	75	80	74	80
8.5	WSC102H4	BAYHTRU409*, BAYHTRA409*	9.0	1	34	40	35	40	34	40
8.5	WSC102H4	BAYHTRU418*, BAYHTRA418*	18.0	1	47	50	49	50	48	50
8.5	WSC102H4	BAYHTRU427*, BAYHTRA427*	27.0	2	61	70	62	70	61	70
8.5	WSC102H4	BAYHTRU436*, BAYHTRA436*	36.0	2	74	80	76	80	75	80
10	WSC120H4	BAYHTRA418*	18.0	1	51	60	—	—	—	—
10	WSC120H4	BAYHTRA427*	27.0	2	65	70	—	—	—	—
10	WSC120H4	BAYHTRA436*	36.0	2	78	80	—	—	—	—
10	WSC120H4	BAYHTRA454*	54.0	2	89	100	—	—	—	—
575 Volts Three Phase										
6	WSC072HW	BAYHTRSW18*	18.0	1	35	35	36	40	—	—
6	WSC072HW	BAYHTRSW27*	27.0	2	46	50	47	50	—	—
6	WSC072HW	BAYHTRSW36*	36.0	2	57	60	57	60	—	—
7.5	WSC090HW	BAYHTRWW18*	18.0	1	35	35	37	40	—	—
7.5	WSC090HW	BAYHTRWW27*	27.0	2	46	50	48	50	—	—
7.5	WSC090HW	BAYHTRWW36*	36.0	2	56	60	58	60	—	—
7.5	WSC092HW	BAYHTRUW18*, BAYHTRAW18*	18.0	1	36	40	38	40	42	45
7.5	WSC092HW	BAYHTRUW27*, BAYHTRAW27*	27.0	2	47	50	49	50	53	60
7.5	WSC092HW	BAYHTRUW36*, BAYHTRAW36*	36.0	2	58	60	60	60	64	70

Electrical Data

Table 5. Unit wiring with electric heat (single point connection) - standard efficiency (continued)

Tons	Unit Model Number	Heater Model Number	Heater kW Rating	Control Stages	Standard Indoor Fan Motor ^(a)		Oversized Indoor fan Motor		Optional EBM Fan Motor	
					MCA	Max Fuse Size or Max Circuit Breaker	MCA	Max Fuse Size or Max Circuit Breaker	MCA	Max Fuse Size or Max Circuit Breaker
8.5	WSC102HW	BAYHTRUW18*, BAYHTRAW18*	18.0	1	38	40	39	40	43	45
8.5	WSC102HW	BAYHTRUW27*, BAYHTRAW27*	27.0	2	49	50	49	50	54	60
8.5	WSC102HW	BAYHTRUW36*, BAYHTRAW36*	36.0	2	59	60	60	60	64	70
10	WSC120HW	BAYHTRAW18*	18.0	1	44	45	—	—	—	—
10	WSC120HW	BAYHTRAW36*	36.0	2	66	70	—	—	—	—
10	WSC120HW	BAYHTRAW54*	54.0	2	75	80	—	—	—	—

(a) The standard motor for the 1-phase models is a multispeed, direct drive motor. The standard motor for 3-phase models (10 ton) is a multispeed, direct drive motor. The standard motor for 3-phase (6 to 7.5 tons) is a belt drive motor.

Table 6. Unit wiring with electric heat (single point connection) - high efficiency

Tons	Unit Model Number	Heater Model Number	Heater kW Rating	Control Stages	Standard Indoor Fan Motor ^(a)		Oversized Indoor Fan Motor		
					MCA	Max Fuse Size or Max Circuit Breaker	MCA	Max Fuse Size or Max Circuit Breaker	
208/230 Volts Three Phase									
6	WHC074H3	BAYHTRA309*	6.8/9.0	1	66/69	70/70	—/—	—/—	
6	WHC074H3	BAYHTRA318*	13.5/18.0	1	89/96	90/100	—/—	—/—	
6	WHC074H3	BAYHTRA327*	20.3/27.0	2	112/123	125/125	—/—	—/—	
6	WHC074H3	BAYHTRA336*	27.0/36.0	2	136/150	150/150	—/—	—/—	
7.5	WHC092H3	BAYHTRA309*	6.8/9.0	1	67/70	70/70	—/—	—/—	
7.5	WHC092H3	BAYHTRA318*	13.5/18.0	1	90/97	90/100	—/—	—/—	
7.5	WHC092H3	BAYHTRA327*	20.3/27.0	2	114/124	125/125	—/—	—/—	
7.5	WHC092H3	BAYHTRA336*	27.0/36.0	2	137/151	150/175	—/—	—/—	
8.5	WHC102H3	BAYHTRA309*	6.8/9.0	1	69/73	80/80	—/—	—/—	
8.5	WHC102H3	BAYHTRA318*	13.5/18.0	1	93/100	100/100	—/—	—/—	
8.5	WHC102H3	BAYHTRA327*	20.3/27.0	2	116/127	125/150	—/—	—/—	
8.5	WHC102H3	BAYHTRA336*	27.0/36.0	2	140/154	150/175	—/—	—/—	
10	WSC120H3	BAYHTRA318*	13.5/18.0	1	95/103	100/110	—/—	—/—	
10	WSC120H3	BAYHTRA327*	20.3/27.0	2	119/130	125/150	—/—	—/—	
10	WSC120H3	BAYHTRA336*	27.0/36.0	2	142/157	150/175	—/—	—/—	
10	WSC120H3	BAYHTRA354*	40.6/54.0	2	189/178	200/200	—/—	—/—	
460 Volts Three Phase									
6	WHC074H4	BAYHTRA409*	9.0	1	33	35	—	—	
6	WHC074H4	BAYHTRA418*	18.0	1	47	50	—	—	
6	WHC074H4	BAYHTRA427*	27.0	2	60	60	—	—	
6	WHC074H4	BAYHTRA436*	36.0	2	74	80	—	—	
7.5	WHC092H4	BAYHTRA409*	9.0	1	34	35	—	—	
7.5	WHC092H4	BAYHTRA418*	18.0	1	47	50	—	—	
7.5	WHC092H4	BAYHTRA427*	27.0	2	61	70	—	—	
7.5	WHC092H4	BAYHTRA436*	36.0	2	74	80	—	—	
8.5	WHC102H4	BAYHTRA409*	9.0	1	35	35	—	—	
8.5	WHC102H4	BAYHTRA418*	18.0	1	49	50	—	—	
8.5	WHC102H4	BAYHTRA427*	27.0	2	62	70	—	—	
8.5	WHC102H4	BAYHTRA436*	36.0	2	76	80	—	—	

Table 6. Unit wiring with electric heat (single point connection) - high efficiency (continued)

Tons	Unit Model Number	Heater Model Number	Heater kW Rating	Control Stages	Standard Indoor Fan Motor ^(a)		Oversized Indoor Fan Motor	
					MCA	Max Fuse Size or Max Circuit Breaker	MCA	Max Fuse Size or Max Circuit Breaker
10	WHC120H4	BAYHTRB418*	18.0	1	51	60	—	—
10	WHC120H4	BAYHTRB427*	27.0	2	64	70	—	—
10	WHC120H4	BAYHTRB436*	36.0	2	78	80	—	—
10	WHC120H4	BAYHTRB454*	54.0	2	89	90	—	—
575 Volts Three Phase								
6	WHC074HW	BAYHTRAW18*	18.0	1	42	45	—	—
6	WHC074HW	BAYHTRAW27*	27.0	2	53	60	—	—
6	WHC074HW	BAYHTRAW36*	36.0	2	64	70	—	—
7.5	WHC092HW	BAYHTRAW18*	18.0	1	43	45	—	—
7.5	WHC092HW	BAYHTRAW27*	27.0	2	54	60	—	—
7.5	WHC092HW	BAYHTRAW36*	36.0	2	65	70	—	—
8.5	WHC102HW	BAYHTRAW18*	18.0	1	44	45	—	—
8.5	WHC102HW	BAYHTRAW27*	27.0	2	55	60	—	—
8.5	WHC102HW	BAYHTRAW36*	36.0	2	66	70	—	—
10	WHC120HW	BAYHTRBW18*	18.0	1	45	45	—	—
10	WHC120HW	BAYHTRBW36*	36.0	2	67	70	—	—
10	WHC120HW	BAYHTRBW54*	54.0	2	75	80	—	—

(a) The standard motor for the 1-phase models is a multispeed, direct drive motor. The standard motor for 3-phase models (10 ton) is a multispeed, direct drive motor. The standard motor for 3-phase (6 to 7.5 tons) is a belt drive motor.

Table 7. Unit wiring with electric heat (single point connection) - high efficiency and eFlex™ - 6 to 10 tons

Tons	Unit Model Number	Heater Model Number	Heater kW Rating ^(a)	Control Stages	Standard Indoor Motor		Oversized Indoor Motor	
					MCA	Max Fuse Size or Max Circuit Breaker	MCA	Max Fuse Size or Max Circuit Breaker
208/230 Volts Three Phase								
6	THC072E/F3	BAYHTRU309*	6.8/9.0	1	32.3/33.4	50/50	33.6/35.0	50/50
6	THC072*3	BAYHTRU318*	13.5/18.0	1	53.1/60.4	60/70	54.8/62.0	60/70
6	THC072*3	BAYHTRU327*	20.3/27.0	2	76.6/87.5	80/90	78.3/89.1	80/90
6	THC072*3	BAYHTRU336*	27.0/36.0	2	100.1/114.5	110/125	101.8/116.1	125/110
6	THC074F3	BAYHTRA309*	6.8/9.0	1	37.4/37.8	50/50	—/—	—/—
6	THC074F3	BAYHTRA318*	13.5/18.0	1	57.5/64.8	60/70	—/—	—/—
6	THC074F3	BAYHTRA327*	20.3/27.0	2	81.0/91.9	90/100	—/—	—/—
6	THC074F3	BAYHTRA336*	27.0/36.0	2	104.5/118.90	110/125	—/—	—/—
6	TZC072F3	BAYHTRA309A	6.8/9	1	18.8/21.7	52/52	—/—	—/—
6	TZC072F3	BAYHTRZ318A	13.5/18	1	37.5/43.3	86/86	—/—	—/—
6	TZC072F3	BAYHTRA327A	20.3/27	2	56.3/65.0	120/120	—/—	—/—
6	TZC072F3	BAYHTRZ336A	27/36	2	75.1/86.6	154/154	—/—	—/—
7.5	THC092F3	BAYHTRA309*	6.8/9.0	1	41.9/41.9	50/50	—/—	—/—
7.5	THC092F3	BAYHTRA318*	13.5/18.0	1	57.5/64.8	60/70	—/—	—/—
7.5	THC092F3	BAYHTRA327*	20.3/27.0	2	81.0/91.9	90/100	—/—	—/—
7.5	THC092F3	BAYHTRA336*	27.0/36.0	2	104.5/118.9	110/125	—/—	—/—
7.5	TZC090F3	BAYHTRA309A	6.8/9	1	18.8/21.7	52/52	—/—	—/—
7.5	TZC090F3	BAYHTRZ318A	13.5/18	1	37.5/43.3	86/86	—/—	—/—
7.5	TZC090F3	BAYHTRA327A	20.3/27	2	56.3/65.0	120/120	—/—	—/—
7.5	TZC090F3	BAYHTRZ336A	27/36	2	75.1/86.6	154/154	—/—	—/—
8.5	THC102F3	BAYHTRA309*	6.8/9.0	1	42.0/42.0	50/50	—/—	—/—

Electrical Data

Table 7. Unit wiring with electric heat (single point connection) - high efficiency and eFlex™ - 6 to 10 tons (continued)

Tons	Unit Model Number	Heater Model Number	Heater kW Rating ^(a)	Control Stages	Standard Indoor Motor		Oversized Indoor Motor	
					MCA	Max Fuse Size or Max Circuit Breaker	MCA	Max Fuse Size or Max Circuit Breaker
8.5	THC102F3	BAYHTRA318*	13.5/18.0	1	57.5/64.8	60/70	—/—	—/—
8.5	THC102F3	BAYHTRA327*	20.3/27.0	2	81.0/91.9	90/100	—/—	—/—
8.5	THC102F3	BAYHTRA336*	27.0/36.0	2	104.5/118.9	110/125	—/—	—/—
8.5	TZC102F3	BAYHTRA309A	6.8/9	1	18.8/21.7	52/52	—/—	—/—
8.5	TZC102F3	BAYHTRZ318A	13.5/18	1	37.5/43.3	86/86	—/—	—/—
8.5	TZC102F3	BAYHTRA327A	20.3/27	2	56.3/65.0	120/120	—/—	—/—
8.5	TZC102F3	BAYHTRZ336A	27/36	2	75.1/86.6	154/154	—/—	—/—
10	THC120F3	BAYHTRD318*	13.5/18.0	1	57.5/64.8	60/70	—/—	—/—
10	THC120F3	BAYHTRD327*	20.3/27.0	2	81.0/91.9	90/100	—/—	—/—
10	THC120F3	BAYHTRD336*	27.0/36.0	2	104.5/118.9	110/125	—/—	—/—
10	THC120F3	BAYHTRD354*	40.6/54.0	2	151.4/140.5	175/150	—/—	—/—
10	TZC120F3	BAYHTRD318A	13.5/18	1	37.5/43.3	86/86	—/—	—/—
10	TZC120F3	BAYHTRD327A	20.3/27	2	56.3/65.0	120/120	—/—	—/—
10	TZC120F3	BAYHTRZ337A	27/36	2	75.1/86.6	154/154	—/—	—/—
10	TZC120F3	BAYHTRZ354A	40.6/54	2	112.6/129.9	181/181	—/—	—/—
460 Volts Three Phase								
6	THC072*4	BAYHTRA409*	9.0	1	16.6	20	17.4	20
6	THC072*4	BAYHTRA418*	18.0	1	30.3	35	31.0	35
6	THC072*4	BAYHTRA427*	27.0	2	43.8	45	44.5	45
6	THC072*4	BAYHTRA436*	36.0	2	57.3	60	58.0	60
6	THC074F4	BAYHTRA409*	9.0	1	18.9	25	—	—
6	THC074F4	BAYHTRA418*	18.0	1	32.5	35	—	—
6	THC074F4	BAYHTRA427*	27.0	2	46.0	50	—	—
460 Volts Three Phase								
6	THC074F4	BAYHTRA436*	36.0	2	59.5	60	—	—
6	TZC072F4	BAYHTRA409A	9	1	10.8	26	—	—
6	TZC072F4	BAYHTRA418A	18	1	21.7	43	—	—
6	TZC072F4	BAYHTRA427A	27	2	32.5	60	—	—
6	TZC072F4	BAYHTRA436A	36	2	43.3	77	—	—
7.5	THC092F4	BAYHTRA409*	9.0	1	19.9	25	—	—
7.5	THC092F4	BAYHTRA418*	18.0	1	32.5	35	—	—
7.5	THC092F4	BAYHTRA427*	27.0	2	46.0	50	—	—
7.5	THC092F4	BAYHTRA436*	36.0	2	59.5	60	—	—
7.5	TZC090F4	BAYHTRA409A	09	1	10.8	26	—	—
7.5	TZC090F4	BAYHTRA418A	18	1	21.7	43	—	—
7.5	TZC090F4	BAYHTRA427A	27	2	32.5	60	—	—
7.5	TZC090F4	BAYHTRA436A	36	2	43.3	77	—	—
8.5	THC102F4	BAYHTRA409*	9.0	1	21.6	25	—	—
8.5	THC102F4	BAYHTRA418*	18.0	1	32.5	35	—	—
8.5	THC102F4	BAYHTRA427*	27.0	2	46.0	50	—	—
8.5	THC102F4	BAYHTRA436*	36.0	2	59.5	60	—	—
8.5	TZC102F4	BAYHTRA409A	09	1	10.8	26	—	—
8.5	TZC102F4	BAYHTRA418A	18	1	21.7	43	—	—
8.5	TZC102F4	BAYHTRA427A	27	2	32.5	60	—	—
8.5	TZC102F4	BAYHTRA436A	36	2	43.3	77	—	—

Table 7. Unit wiring with electric heat (single point connection) - high efficiency and eFlex™ - 6 to 10 tons (continued)

Tons	Unit Model Number	Heater Model Number	Heater kW Rating ^(a)	Control Stages	Standard Indoor Motor		Oversized Indoor Motor	
					MCA	Max Fuse Size or Max Circuit Breaker	MCA	Max Fuse Size or Max Circuit Breaker
10	THC120F4	BAYHTRD418*	18.0	1	32.5	35	—	—
10	THC120F4	BAYHTRD427*	27.0	2	46.0	50	—	—
10	THC120F4	BAYHTRD436*	36.0	2	59.5	60	—	—
10	THC120F4	BAYHTRD454*	54.0	2	70.4	80	—	—
10	TZC120F4	BAYHTRD418A	18	1	21.7	43	—	—
10	TZC120F4	BAYHTRD427A	27	2	32.5	60	—	—
10	TZC120F4	BAYHTRZ436A	36	2	43.3	77	—	—
10	TZC120F4	BAYHTRZ454A	54	2	65.0	91	—	—
575 Volts Three Phase								
6	TZC072FW	BAYHTRAW18*	18	1	17.3	37	—	—
6	TZC072FW	BAYHTRAW36*	36	2	34.6	64	—	—
7.5	TZC090FW	BAYHTRAW18*	18	1	17.3	37	—	—
7.5	TZC090FW	BAYHTRAW36*	36	2	34.6	64	—	—
8.5	TZC102FW	BAYHTRAW18*	18	1	17.3	37	—	—
8.5	TZC102FW	BAYHTRAW36*	36	2	34.6	64	—	—
10	TZC120FW	BAYHTRBW18*	18	1	17.3	37	—	—
10	TZC120FW	BAYHTRZW36*	36	2	34.6	64	—	—
10	TZC120FW	BAYHTRZW54*	54	2	52.0	75	—	—

(a) Heater kW ratings are at 208V/240V for 208V/230V units, 480V for 460V units.

Table 8. Air temperature rise 380/415 volt (50 Hz)^(a)

(Degrees °C) ^(b)						(Degrees °F) ^(c)					
kW	Voltage	Stages	6 Ton	7.5 Ton	10 Ton	kW	Voltage	Stages	6 Ton	7.5 Ton	10 Ton
			4100 M ³ /H	5100 M ³ /H	6800 M ³ /H				2400 cfm	3000 cfm	4000 cfm
			WSC072ED	WSC090ED	WSC120 ED				WSC072ED	WSC090E D	WSC120E D
11.3	380-415/50/3	1	8.3	6.6	—	11.3	380-415/50/3	1	14.9	11.9	—
12.5	380-415/50/3	1	9.1	7.3	—	12.5	380-415/50/3	1	16.5	13.2	—
13.5	380-415/50/3	1	9.9	7.9	—	13.5	380-415/50/3	1	17.8	14.2	—
16.9	380-415/50/3	2	12.4	9.9	7.4	16.9	380-415/50/3	2	22.3	17.8	13.4
18.8	380-415/50/3	2	13.8	11.0	8.3	18.8	380-415/50/3	2	24.8	19.8	14.9
20.2	380-415/50/3	2	14.8	11.8	8.9	20.2	380-415/50/3	2	26.6	21.3	16.0
22.6	380-415/50/3	2	16.5	13.2	9.9	22.6	380-415/50/3	2	29.8	23.8	17.9
25.0	380-415/50/3	2	18.3	14.6	11.0	25.0	380-415/50/3	2	32.9	26.3	19.8
26.9	380-415/50/3	2	19.7	15.7	11.8	26.9	380-415/50/3	2	35.4	28.3	21.3
33.9	380-415/50/3	2	—	—	14.9	33.9	380-415/50/3	2	—	—	26.8
37.5	380-415/50/3	2	—	—	16.5	37.5	380-415/50/3	2	—	—	29.6
40.4	380-415/50/3	2	—	—	17.7	40.4	380-415/50/3	2	—	—	31.9

(a) For minimum design airflow, see performance table for each unit.

(b) To calculate the temperature rise in Celsius at different airflow, use the following formula: Temperature rise (°C) across electric heater = (kW x 2985)/(M³/H).

(c) To calculate the temperature rise in Fahrenheit at different airflow, use the following formula: Temperature rise (°F) across electric heater = (kW x 3414)/(1.08/H).

Electrical Data

Table 9. Air temperature rise 380/415 volt (50 Hz)^(a)

(Degrees °C) ^(b)							(Degrees °F) ^(c)						
kW	Voltage	Stages	6 Ton	7.5 Ton	8.5 Ton	10 Ton	kW	Voltage	Stages	6 Ton	7.5 Ton	8.5 Ton	10 Ton
			4100 M ³ /H	5100 M ³ /H	5800 M ³ /H	6800 M ³ /H				2400 cfm	3000 cfm	3400 cfm	4000 cfm
			TSC072E D	TSC090E D	TSC102E D	TSC120E D				TSC072 ED	TSC090 ED	TSC102 ED	TSC120 ED
11.3/13.5	380-415/50/3	1	8.3/9.9	6.6/7.9	—	—	11.3/13.5	380-415/50/3	1	14.9/ 17.8	11.9/ 14.2	—	—
16.9/20.2	380-415/50/3	2	12.4/14.8	9.9/11.8	8.7/10.4	7.4/8.9	16.9/20.2	380-415/50/3	2	22.3/ 26.6	17.8/ 21.3	15.7/ 18.8	13.4/ 16.0
22.6/26.9	380-415/50/3	2	16.5/19.7	13.2/15.7	11.7/13.9	9.9/11.8	22.6/26.9	380-415/50/3	2	29.8/ 35.4	23.8/ 28.3	21.0/ 25.0	17.9/ 21.3
33.8/40.4	380-415/50/3	2	—	—	—	14.8 / 17.7	33.8/40.4	380-415/50/3	2	—	—	—	26.7/ 31.9

(a) For minimum design airflow, see performance table for each unit.

(b) To calculate the temperature rise in Celsius at different airflow, use the following formula: Temperature rise (°C) across electric heater = (kW x 2985)/(M³/H).

(c) To calculate the temperature rise in Fahrenheit at different airflow, use the following formula: Temperature rise (°F) across electric heater = (kW x 3414)/(1.08/H).

Table 10. Cooling only units with electric heater — single power source — 380/415 volt three phase (50 Hz)

Unit Model No.	Heater Model No.	Heater ^(a) kW Rating	Heater ^(a) MBh	Control Stages	Standard Indoor Fan Motor		Oversized Indoor Fan Motor	
					MCA	Maximum Fuse Size Or Maximum Circuit Breaker	MCA	Maximum Fuse Size Or Maximum Circuit Breaker
TSC072ED	BAYHTRS418	11.3/13.5	39/47	1	26.9/28.9	35/35	28.1/30.1	35/35
	BAYHTRS427	16.9/20.2	58/69	2	37.5/40.5	40/45	38.8/41.8	40/45
	BAYHTRS436	22.6/26.9	78/92	2	48.3/52.1	50/60	49.5/53.4	50/60
TSC090ED	BAYHTRS418	11.3/13.5	39/47	1	28.1/30.1	35/35	30.3/32.3	35/35
	BAYHTRS427	16.9/20.2	58/69	2	38.8/41.8	40/45	40.9/43.9	45/45
	BAYHTRS436	22.6/26.9	78/92	2	49.5/53.4	50/60	51.6/55.5	60/60
TSC102ED	BAYHTRT427	16.9/20.2	58/69	2	38.8/41.8	40/45	40.9/43.9	45/45
	BAYHTRT436	22.6/26.9	78/92	2	49.5/53.4	50/60	51.6/55.5	60/60
TSC120ED	BAYHTRT427	16.9/20.2	58/69	2	40.9/43.9	45/45	40.9/43.9	45/45
	BAYHTRT436	22.6/26.9	78/92	2	51.6/55.5	60/60	51.6/55.5	60/60
	BAYHTRT454	33.8/40.4	116/138	2	73.1/79.0	80/80	73.1/79.0	80/80

(a) kW and MBh shown for 380V/415V.

Table 11. Heat pump units with electric heater — single power source — 380/415 volt three phase (50 Hz)

Unit Model No.	Heater Model No.	Heater ^(a) kW Rating	Heater ^(a) MBh	Control Stages	Standard Indoor Fan Motor		Oversized Indoor Fan Motor	
					MCA	Maximum Fuse Size Or Maximum Circuit Breaker	MCA	Maximum Fuse Size Or Maximum Circuit Breaker
WSC072ED	BAYHTRS418	11.3/13.5	39/47	1	43.4/45.4	50/50	44.4/46.4	50/50
	BAYHTRS427	16.9/20.2	58/69	2	54.1/57.1	60/60	55.1/58.1	60/60
	BAYHTRS436	22.6/26.9	78/92	2	64.8/68.7	70/70	65.8/69.7	70/70
WSC090ED	BAYHTRS418	11.3/13.5	39/47	1	46.3/48.3	50/50	48.0/50.0	50/50
	BAYHTRS427	16.9/20.2	58/69	2	56.9/59.9	60/60	58.6/61.6	60/60
	BAYHTRS436	22.6/26.9	78/92	2	67.7/71.6	70/70	69.4/73.3	70/70
WSC120ED	BAYHTRT427	16.9/20.2	58/69	2	63.3/66.3	70/70	—	—
	BAYHTRT436	22.6/26.9	78/92	2	74.0/77.9	80/80	—	—
	BAYHTRT454	33.9/40.4	116/138	2	95.5/101.4	100/110	—	—

(a) kW and MBh shown for 380V/415V.

Notes

Trane and American Standard create comfortable, energy efficient indoor environments for commercial and residential applications. For more information, please visit trane.com or americanstandardair.com.

Trane and American Standard have a policy of continuous product and product data improvement and reserve the right to change design and specifications without notice. We are committed to using environmentally conscious print practices.