

Installation Instructions

Discharge Air Sensing Kit

Model Number: BAYTUBE004* **Used With:** Gas/Electric Precedent™ units with ReliaTel™ control, in size B or F cabinet, model digit 1 = Y/D and digit 30 = B/F.

SAFETY WARNING

Only qualified personnel should install and service the equipment. The installation, starting up, and servicing of heating, ventilating, and air-conditioning equipment can be hazardous and requires specific knowledge and training. Improperly installed, adjusted or altered equipment by an unqualified person could result in death or serious injury. When working on the equipment, observe all precautions in the literature and on the tags, stickers, and labels that are attached to the equipment.

March 2020

ACC-SVN58H-EN

© 2020 Trane

1

Warnings, Cautions, and Notices

Read this manual thoroughly before operating or servicing this unit. Safety advisories appear throughout this manual as required. Your personal safety and the proper operation of this machine depend upon the strict observance of these precautions.

The three types of advisories are defined as follows:

WARNING

Indicates a potentially hazardous situation which, if not avoided, could result in death or serious injury.

CAUTION

Indicates a potentially hazardous situation which, if not avoided, could result in minor or moderate injury. It could also be used to alert

NOTICE

Indicates a situation that could result in equipment or property-damage only accidents.

Important Environmental Concerns

Scientific research has shown that certain man-made chemicals can affect the earth's naturally occurring stratospheric ozone layer when released to the atmosphere. In particular, several of the identified chemicals that may affect the ozone layer are refrigerants that contain Chlorine, Fluorine and Carbon (CFCs) and those containing Hydrogen, Chlorine, Fluorine and Carbon (HCFCs). Not all refrigerants containing these compounds have the same potential impact to the environment. Trane advocates the responsible handling of all refrigerants-including industry replacements for CFCs such as HCFCs and HFCs.

Important Responsible Refrigerant Practices

Trane believes that responsible refrigerant practices are important to the environment, our customers, and the air conditioning industry. All technicians who handle refrigerants must be certified according to local rules. For the USA, the Federal Clean Air Act (Section 608) sets forth the requirements for handling, reclaiming, recovering and recycling of certain refrigerants and the equipment that is used in these service procedures. In addition, some states or municipalities may have additional requirements that must also be adhered to for responsible management of refrigerants. Know the applicable laws and follow them.

2

WARNING

Proper Field Wiring and Grounding Required!

Failure to follow code could result in death or serious injury. All field wiring MUST be performed by qualified personnel. Improperly installed and grounded field wiring poses FIRE and ELECTROCUTION hazards. To avoid these hazards, you MUST follow requirements for field wiring installation and grounding as described in NEC and your local/state electrical codes.

WARNING

Personal Protective Equipment Required!

Installing/servicing this unit could result in exposure to electrical, mechanical and chemical hazards. Before installing/servicing this unit, technicians MUST put on all Personal Protective Equipment (PPE) recommended for the work being undertaken. ALWAYS refer to appropriate SDS sheets and OSHA guidelines for proper PPE. When working with or around hazardous chemicals, ALWAYS refer to the appropriate SDS sheets and OSHA guidelines for information on allowable personal exposure levels, proper respiratory protection and handling recommendations. If there is a risk of arc or flash, technicians MUST put on all necessary Personal Protective Equipment (PPE) in accordance with NFPA70E for arc/flash protection PRIOR to servicing the unit. Failure to follow recommendations could result in death or serious injury.

WARNING

Follow EHS Policies!

Failure to follow instructions below could result in death or serious injury.

- All Trane personnel must follow the company's Environmental, Health and Safety (EHS) policies when performing work such as hot work, electrical, fall protection, lockout/tagout, refrigerant handling, etc. Where local regulations are more stringent than these policies, those regulations supersede these policies.
- Non-Trane personnel should always follow local regulations.

General Information

This discharge air sensing kit is designed to sense the supply air temperature downstream of the heat exchanger.

3

Inspection

1. Unpack all components of the kit.
2. Check carefully for any shipping damage. If any damage is found it must be reported immediately and a claim made against the transportation company.

Parts List

- 1 - Sensing Tube
- 1 - Sensor Cap assembly
- 1 - Mounting Bracket
- 1 - Wire Harness
- 2 - Screws
- 2 - Wire Ties

Installation Procedure

WARNING

Hazardous Voltage w/Capacitors!

Failure to disconnect power and discharge capacitors before servicing could result in death or serious injury. Disconnect all electric power, including remote disconnects and discharge all motor start/run capacitors before servicing. Follow proper lockout/tagout procedures to ensure the power cannot be inadvertently energized. Verify with an appropriate voltmeter that all capacitors have discharged.

For additional information regarding the safe discharge of capacitors, see PROD-SVB06A-EN

1. Turn the main power disconnect switch "OFF".
2. Remove the supply fan access panel.
3. Remove the plug button located in the space between the fan housing and the indoor/outdoor section divider panel. The sensor tube will enter the fan compartment at this location. Refer to [Figure 1](#).

4

Figure 1. Sensor Cap Assembly

Place sensor cap assembly over sensing tube

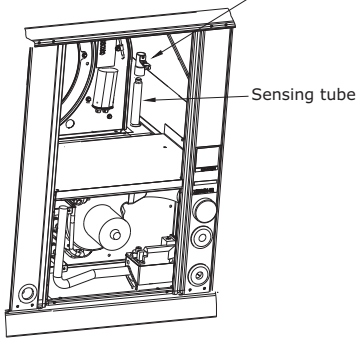

4. Remove the heat access panel on the rear side of the unit.
5. Insert the sensing tube through the hole as shown in [Figure 2](#).

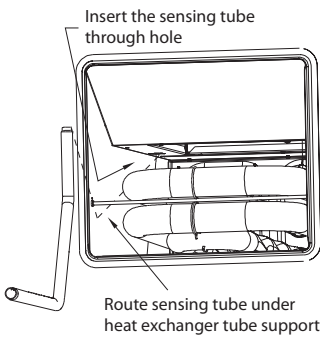
Figure 2. Insert the Sensing Tube

5

6. Install the mounting bracket on the sensing tube. Refer to [Figure 3](#) for mounting bracket/sensing tube configuration.

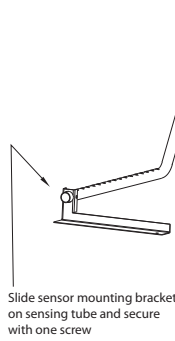
Figure 3. Sensor Mounting Bracket

7. Place the mounting bracket down on the base pan. Using the screw supplied, secure the mounting bracket to the unit. Secure the sensing tube to the mounting bracket with screw provided. Refer to [Figure 4](#).

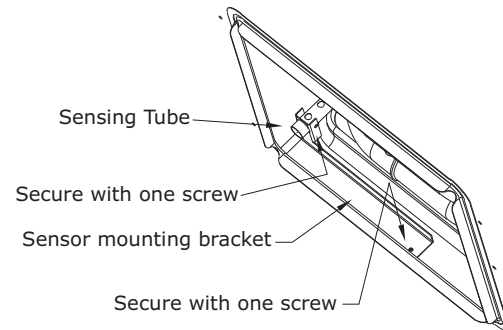
Figure 4. Mounting Bracket

6

8. Move to the front of the unit. Place the sensor cap assembly over the sensor tube. Refer to [Figure 1](#).
9. Connect the ends of the sensor wires to the intermediate wiring harness supplied. Wire 148A (violet) and 149A (blue).
10. Connect the opposite ends of the supplied intermediate wiring harness to pins J4-4 & J4-5 on the options board. Refer to [Figure 5](#).

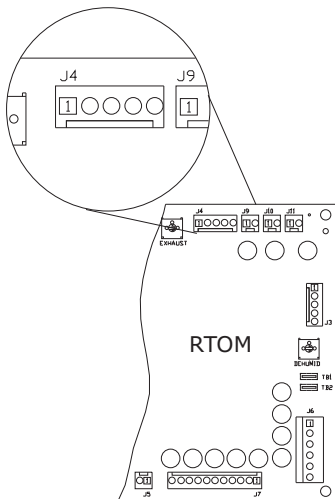
Figure 5. Options Board

11. Route the sensor leads and attached harness leads and fasten securely with wire ties.
 - a. Digit 30 = B - RTOM is located on the divider wall in the fan compartment.
 - b. Digit 30 = F - RTOM is located in the low voltage section of the control box.

7

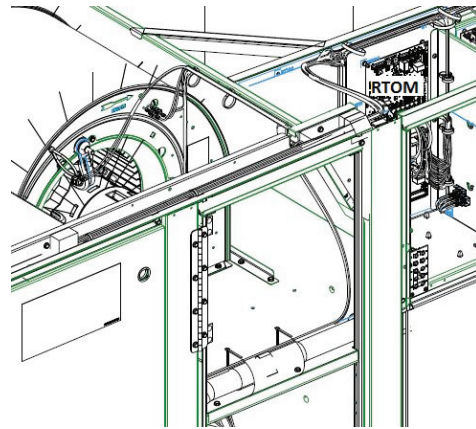
Figure 6. F Cabinet - RTOM location

12. Replace all access panels.
13. Turn the main power disconnect switch to "On".

Trane and American Standard create comfortable, energy efficient indoor environments for commercial and residential applications. For more information, please visit trane.com or americanstandardair.com.

Trane and American Standard have a policy of continuous product and product data improvement and reserve the right to change design and specifications without notice. We are committed to using environmentally conscious print practices.