

# Installation Instructions

## Discharge Air Sensing Kit

**Model Number:** BAYTUBE007\* **Used With:** Precedent Cooling and Heat Pump models with ReliaTel control and forward curved fan (Digit 1 = T/W and Digit 30 = C/D)

**SAFETY WARNING**  
Only qualified personnel should install and service the equipment. The installation, starting up, and servicing of heating, ventilating, and air-conditioning equipment can be hazardous and requires specific knowledge and training. Improperly installed, adjusted or altered equipment by an unqualified person could result in death or serious injury. When working on the equipment, observe all precautions in the literature and on the tags, stickers, and labels that are attached to the equipment.

April 2020

ACC-SVN53J-EN

© 2020

### 1 Warnings, Cautions, and Notices

Read this manual thoroughly before operating or servicing this unit. Safety advisories appear throughout this manual as required. Your personal safety and the proper operation of this machine depend upon the strict observance of these precautions.

The three types of advisories are defined as follows:

- WARNING** Indicates a potentially hazardous situation which, if not avoided, could result in death or serious injury.
- CAUTION** Indicates a potentially hazardous situation which, if not avoided, could result in minor or moderate injury. It could also be used to alert against unsafe practices.
- NOTICE** Indicates a situation that could result in equipment or property-damage only accidents.

#### Important Environmental Concerns

Scientific research has shown that certain man-made chemicals can affect the earth's naturally occurring stratospheric ozone layer when released to the atmosphere. In particular, several of the identified chemicals that may affect the ozone layer are refrigerants that contain Chlorine, Fluorine and Carbon (CFCs) and those containing Hydrogen, Chlorine, Fluorine and Carbon (HCFCs). Not all refrigerants containing these compounds have the same potential impact to the environment. Trane advocates the responsible handling of all refrigerants-including industry replacements for CFCs such as HCFCs and HFCs.

#### Important Responsible Refrigerant Practices

Trane believes that responsible refrigerant practices are important to the environment, our customers, and the air conditioning industry. All technicians who handle refrigerants must be certified according to local rules. For the USA, the Federal Clean Air Act (Section 608) sets forth the requirements for handling, reclaiming, recovering and recycling of certain refrigerants and the equipment that is used in these service procedures. In addition, some states or municipalities may have additional requirements that must also be adhered to for responsible management of refrigerants. Know the applicable laws and follow them.

### 2 WARNING

**Proper Field Wiring and Grounding Required!**  
Failure to follow code could result in death or serious injury. All field wiring MUST be performed by qualified personnel. Improperly installed and grounded field wiring poses FIRE and ELECTROCUTION hazards. To avoid these hazards, you MUST follow requirements for field wiring installation and grounding as described in NEC and your local/state electrical codes.

### WARNING

**Personal Protective Equipment Required!**  
Installing/servicing this unit could result in exposure to electrical, mechanical and chemical hazards. Before installing/servicing this unit, technicians MUST put on all Personal Protective Equipment (PPE) recommended for the work being undertaken. ALWAYS refer to appropriate SDS sheets and OSHA guidelines for proper PPE. When working with or around hazardous chemicals, ALWAYS refer to the appropriate SDS sheets and OSHA guidelines for information on allowable personal exposure levels, proper respiratory protection and handling recommendations. If there is a risk of arc or flash, technicians MUST put on all necessary Personal Protective Equipment (PPE) in accordance with NFPA70E for arc/flash protection PRIOR to servicing the unit. Failure to follow recommendations could result in death or serious injury.

### WARNING

**Follow EHS Policies!**  
Failure to follow instructions below could result in death or serious injury.

- All Trane personnel must follow the company's Environmental, Health and Safety (EHS) policies when performing work such as hot work, electrical, fall protection, lockout/tagout, refrigerant handling, etc. Where local regulations are more stringent than these policies, those regulations supersede these policies.
- Non-Trane personnel should always follow local regulations.

#### General Information

This instruction covers installation of BAYTUBE007\* in 4 to 10 ton Electric/Electric and Heat Pump units. Follow the installation instructions carefully.

### 3 Model Number Description

All products are identified by a multiple-character model number that precisely identifies a particular type of unit. Its use will enable the owner/operator, installing contractors, and service engineers to define the operation, specific components, and other options for any specific unit. When ordering replacement parts or requesting service, be sure to refer to the specific model number and serial number printed on the unit nameplate.

#### Inspection

1. Unpack all components of the kit.
2. Check carefully for any shipping damage. If any damage is found it must be reported immediately and a claim made against the transportation company.

#### Parts List

- 1 - Sensing Tube
- 1 - Sensor Cap and Harness assembly
- 1 - Mounting Bracket
- 4 - Screws
- 3 - Wire Ties
- 1 - Aluminum Foil tape
- 1 - Adapter Tube Elbow

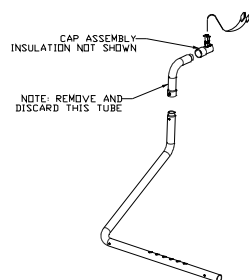
### 4 Installation

#### WARNING

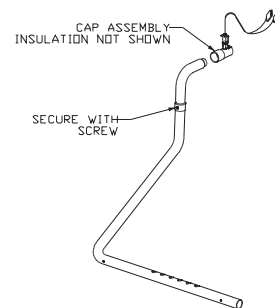
**Hazardous Voltage w/Capacitors!**  
Failure to disconnect power and discharge capacitors before servicing could result in death or serious injury. Disconnect all electric power, including remote disconnects and discharge all motor start/run capacitors before servicing. Follow proper lockout/tagout procedures to ensure the power cannot be inadvertently energized. For variable frequency drives or other energy storing components provided by Trane or others, refer to the appropriate manufacturer's literature for allowable waiting periods for discharge of capacitors. Verify with an appropriate voltmeter that all capacitors have discharged.

For additional information regarding the safe discharge of capacitors, see PROD-SVB06A-EN

Figure 1. For C cabinet models (Digit 30=C)



5 Figure 2. For D cabinet models (Digit 30=D)



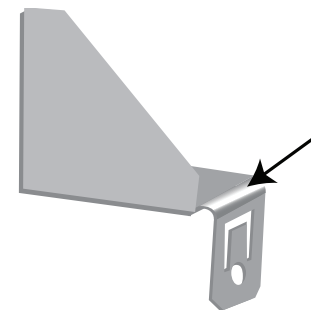
1. Turn the main power disconnect switch "OFF".
2. Remove the supply fan access panel.
3. For C cabinet models (Digit 30=C)  
Remove the plug button located in the space between the fan housing and the indoor/outdoor section divider panel. The sensor tube will enter the fan compartment at this location. Refer to Figure 12.
- For D cabinet models (Digit 30=D)  
Remove the knockout located on the side of the fan housing. The sensor tube will enter the fan compartment at this location. Refer to Figure 13.
4. Remove the supply air duct cover on the rear side of the unit.
5. Bend clip with flat head screwdriver on mounting bracket approximately 20° down. Refer to Figure 3.

6 Figure 3.



**Note:** For units without slot clearance hole, bend tab at flat edge down 90°. Refer to Figure 4.

Figure 4.



6. Install the mounting bracket through the heat access panel on the rear side of the unit. Insert bracket into unit clip end first. Place clip end in slot and rotate other side of bracket until side flange is parallel with recess on side of duct opening (bend left side in slightly during installation to ensure no damage to insulation occurs). Refer to Figure 5, Figure 6 and Figure 7. Rotate left side down allowing side flange to sit in recess on side of duct opening. Refer to Figure 6.

7 Figure 5.



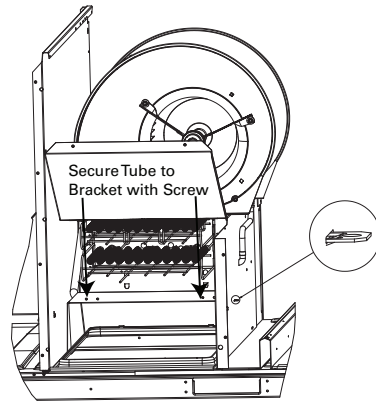
Figure 6.



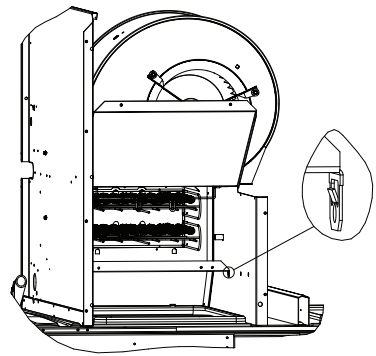
**Note:** For units without slot clearance hole use self tapping screw to secure bracket in unit. Refer to Figure 7. Secure screw at 20 inches from back edge of wrapper. Refer to Figure 8.

8

**Figure 7. For C cabinet models (Digit 30=C)**



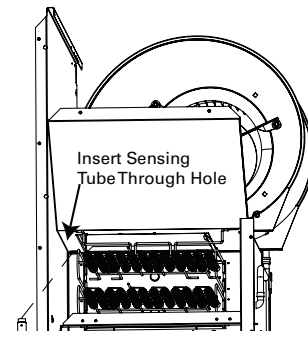
**Figure 8.**



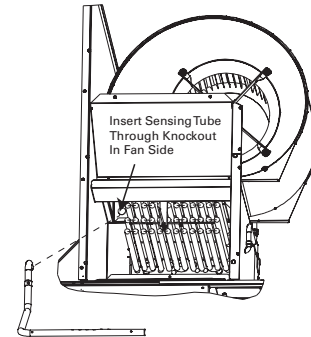
9

7. Install the sensing tube through the hole as shown in [Figure 9](#) or [Figure 10](#). Secure the tube to the mounting bracket as shown in [Figure 7](#) or [Figure 11](#).

**Figure 9. For C cabinet models (Digit 30=C)**

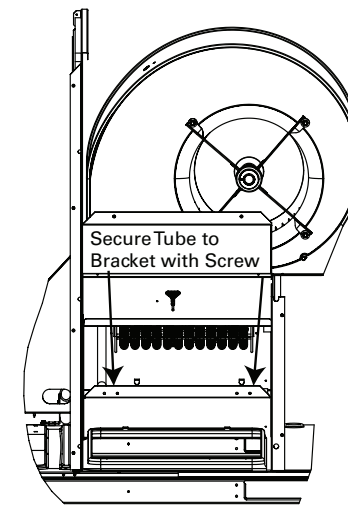


**Figure 10. For D cabinet models (Digit 30=D)**



10

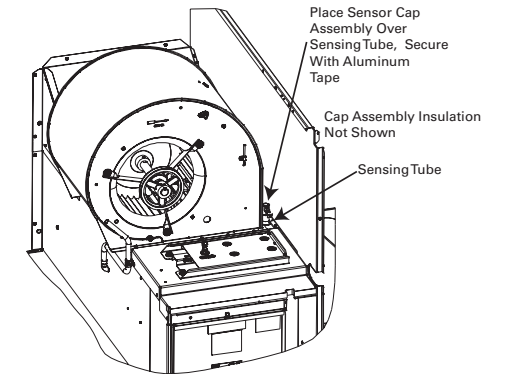
**Figure 11. For D cabinet models (Digit 30=D)**



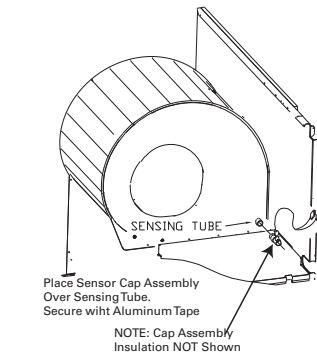
8. Move to the front of the unit. Place the sensor cap assembly over the sensor tube. Secure sensor cap assembly to sensor tube with aluminum foil tape. Verify that insulation is installed around cap assembly with a wire tie. Refer to [Figure 12](#) or [Figure 13](#).

11

**Figure 12. For C cabinet models (Digit 30=C)**



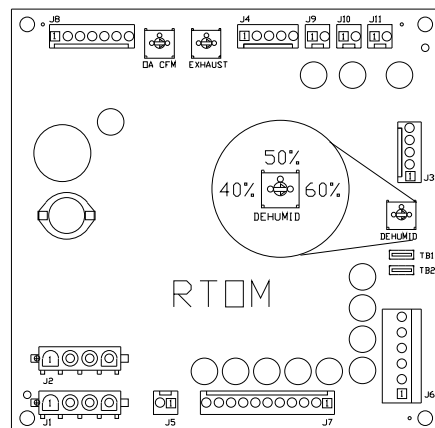
**Figure 13. For D cabinet models (Digit 30=D)**



12

9. Connect the ends of the sensor wires to the intermediate wiring harness supplied. Wire 148A (violet) and 149A (blue).
10. Connect the opposite ends of the supplied intermediate wiring harness to pins J4-4 & J4-5 on the options board. Refer to [Figure 14](#).
11. Route the sensor leads and attached harness leads along the fan motor lead path and fasten securely with wire ties.
12. Replace access panel and duct cover.
13. Turn the main power disconnect switch to "On".

**Figure 14.**



Trane and American Standard create comfortable, energy efficient indoor environments for commercial and residential applications. For more information, please visit [trane.com](http://trane.com) or [americanstandardair.com](http://americanstandardair.com).

Trane and American Standard have a policy of continuous product and product data improvement and reserve the right to change design and specifications without notice. We are committed to using environmentally conscious print practices.