

Installation Instructions

Power Exhaust Kit

Foundation™ Packaged Rooftop Units 15 to 25 Tons

Model Numbers:	Used With:
BAYPWRX303*	G/EDK180-300A3
BAYPWRX304*	G/EDK180-300A4
BAYPWRX305*	G/EDK180-300AW

SAFETY WARNING

Only qualified personnel should install and service the equipment. The installation, starting up, and servicing of heating, ventilating, and air-conditioning equipment can be hazardous and requires specific knowledge and training. Improperly installed, adjusted or altered equipment by an unqualified person could result in death or serious injury. When working on the equipment, observe all precautions in the literature and on the tags, stickers, and labels that are attached to the equipment.

Introduction

Read this manual thoroughly before operating or servicing this unit.

Warnings, Cautions, and Notices

Safety advisories appear throughout this manual as required. Your personal safety and the proper operation of this machine depend upon the strict observance of these precautions.

The three types of advisories are defined as follows:

- ⚠ WARNING** Indicates a potentially hazardous situation which, if not avoided, could result in death or serious injury.
- ⚠ CAUTION** Indicates a potentially hazardous situation which, if not avoided, could result in minor or moderate injury. It could also be used to alert against unsafe practices.
- NOTICE** Indicates a situation that could result in equipment or property-damage only accidents.

Important Environmental Concerns

Scientific research has shown that certain man-made chemicals can affect the earth's naturally occurring stratospheric ozone layer when released to the atmosphere. In particular, several of the identified chemicals that may affect the ozone layer are refrigerants that contain Chlorine, Fluorine and Carbon (CFCs) and those containing Hydrogen, Chlorine, Fluorine and Carbon (HCFCs). Not all refrigerants containing these compounds have the same potential impact to the environment. Trane advocates the responsible handling of all refrigerants.

Important Responsible Refrigerant Practices

Trane believes that responsible refrigerant practices are important to the environment, our customers, and the air conditioning industry. All technicians who handle refrigerants must be certified according to local rules. For the USA, the Federal Clean Air Act (Section 608) sets forth the requirements for handling, reclaiming, recovering and recycling of certain refrigerants and the equipment that is used in these service procedures. In addition, some states or municipalities may have additional requirements that must also be adhered to for responsible management of refrigerants. Know the applicable laws and follow them.

⚠ WARNING

Proper Field Wiring and Grounding Required!

Failure to follow code could result in death or serious injury. All field wiring **MUST** be performed by qualified personnel. Improperly installed and grounded field wiring poses **FIRE** and **ELECTROCUTION** hazards. To avoid these hazards, you **MUST** follow requirements for field wiring installation and grounding as described in **NEC** and your local/state/national electrical codes.

⚠ WARNING

Personal Protective Equipment (PPE) Required!

Failure to wear proper PPE for the job being undertaken could result in death or serious injury. Technicians, in order to protect themselves from potential electrical, mechanical, and chemical hazards, **MUST** follow precautions in this manual and on the tags, stickers, and labels, as well as the instructions below:

- Before installing/servicing this unit, technicians **MUST** put on all PPE required for the work being undertaken (Examples; cut resistant gloves/sleeves, butyl gloves, safety glasses, hard hat/bump cap, fall protection, electrical PPE and arc flash clothing). **ALWAYS** refer to appropriate Safety Data Sheets (SDS) and OSHA guidelines for proper PPE.
- When working with or around hazardous chemicals, **ALWAYS** refer to the appropriate SDS and OSHA/GHS (Global Harmonized System of Classification and Labeling of Chemicals) guidelines for information on allowable personal exposure levels, proper respiratory protection and handling instructions.
- If there is a risk of energized electrical contact, arc, or flash, technicians **MUST** put on all PPE in accordance with OSHA, NFPA 70E, or other country-specific requirements for arc flash protection, **PRIOR** to servicing the unit. **NEVER PERFORM ANY SWITCHING, DISCONNECTING, OR VOLTAGE TESTING WITHOUT PROPER ELECTRICAL PPE AND ARC FLASH CLOTHING. ENSURE ELECTRICAL METERS AND EQUIPMENT ARE PROPERLY RATED FOR INTENDED VOLTAGE.**

⚠ WARNING

Follow EHS Policies!

Failure to follow instructions below could result in death or serious injury.

- All Trane personnel must follow the company's Environmental, Health and Safety (EHS) policies when performing work such as hot work, electrical, fall protection, lockout/tagout, refrigerant handling, etc. Where local regulations are more stringent than these policies, those regulations supersede these policies.
- Non-Trane personnel should always follow local regulations.

⚠ WARNING

R-454B Flammable A2L Refrigerant!

Failure to use proper equipment or components as described below could result in equipment failure, and possibly fire, which could result in death, serious injury, or equipment damage.

The equipment described in this manual uses R-454B refrigerant which is flammable (A2L). Use ONLY R-454B rated service equipment and components. For specific handling concerns with R-454B, contact your local representative.

Copyright

This document and the information in it are the property of Trane, and may not be used or reproduced in whole or in part without written permission. Trane reserves the right to revise this publication at any time, and to make changes to its content without obligation to notify any person of such revision or change.

Trademarks

All trademarks referenced in this document are the trademarks of their respective owners.

Table of Contents

General Information	5
Inspection	5
Parts List	5
Installation	7
Internal Block-Off Gasket Seals	7
Comparative Enthalpy	8
Differential Dry Bulb	8
Block-Off Assembly	8
Block-Off Assembly	9
Power Exhaust Assembly	10
Wiring Installation	12
Power Wiring	12
Control Wiring	12
Unit Power Exhaust Operation and Settings	14
Standard Economizer	14
Low Leak Economizer	14
Final Installation Steps	14

General Information

Carefully review installation instructions.

- Power exhaust is designed for down flow applications.
- For horizontal applications, the power exhaust may be mounted on the horizontal return duct.

Note: The installing technician is responsible for the installation.

- Install the economizer and verify functionality before installing the power exhaust.

Inspection

1. Unpack all components of the kit.
2. Check carefully for shipping damage. If any damage is found, report it immediately, and file a claim against the transportation company.

Parts List

Figure 1. Major power exhaust components

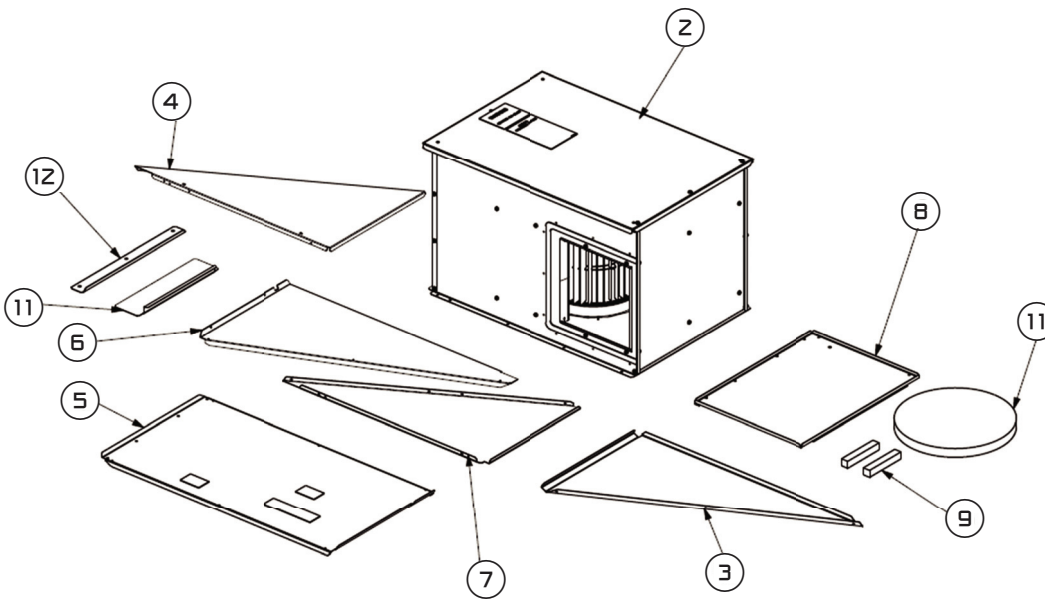

Table 1. Major power exhaust components

Item	Description	Qty
2	Power Exhaust Assembly	1
3**	Internal Blockoff, Left Alternate Duct	1
4	Internal Blockoff, Right	1
5	Internal Blockoff, Center	1
6**	Internal Blockoff, Center Alternate Duct	1
7*	Internal Blockoff, Left Trane Duct	1
8	Horizontal Return Blockoff	1
9	1-in. x 1-in. x 6-in. Gasket	2
10	0.25-in. x 1-in. x 13-ft. Gasket	1
11*	Internal Base Duct Blockoff	1

General Information

Table 1. Major power exhaust components (continued)

Item	Description	Qty
12	Power Exhaust Alignment Bracket	1

Note: The power exhaust assembly is designed to work with either the return duct opening farthest from the evaporator coil or the alternate return duct opening (closest to the evaporator coil).

- Items used only on return duct opening farthest from the evaporator coil are designated with *.
- Items used only on the alternate duct configuration are designated with **.
- All other items are common to both configurations.

Components not Shown:

Description
¼ x 20 x 5/8 Screws
#10 x 14 x 3/4 Screws
7.78 in. Wire Tie
11.0 in. Wire Tie
0.94-in. ID Bushing
0.56-in. ID Bushing
1-in. x 3-in. Power Exhaust Installed Label

Installation

⚠ WARNING

Hazardous Service Procedures!

Failure to follow all precautions in this manual and on the tags, stickers, and labels could result in death or serious injury.

Technicians, in order to protect themselves from potential electrical, mechanical, and chemical hazards, **MUST** follow precautions in this manual and on the tags, stickers, and labels, as well as the following instructions: Unless specified otherwise, disconnect all electrical power including remote disconnect and discharge all energy storing devices such as capacitors before servicing. Follow proper lockout/tagout procedures to ensure the power can not be inadvertently energized. When necessary to work with live electrical components, have a qualified licensed electrician or other individual who has been trained in handling live electrical components perform these tasks.

1. Open and lock unit disconnect before attempting to install this accessory.
2. Remove the supply fan and filter access panels from front side of the unit.
3. Remove horizontal duct cover.
4. Remove economizer duct block-off.

Figure 2. Remove panels

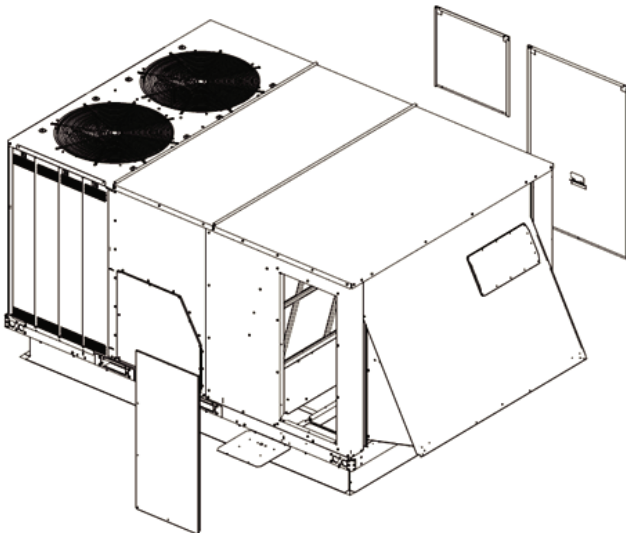

Internal Block-Off Gasket Seals

Standard Economizer: Attach one gasket (9) to the base, aligned with the economizer Return Air Damper (RAD) bracket. See [Figure 3](#).

Figure 3. Attach gasket to base and blockoff panel

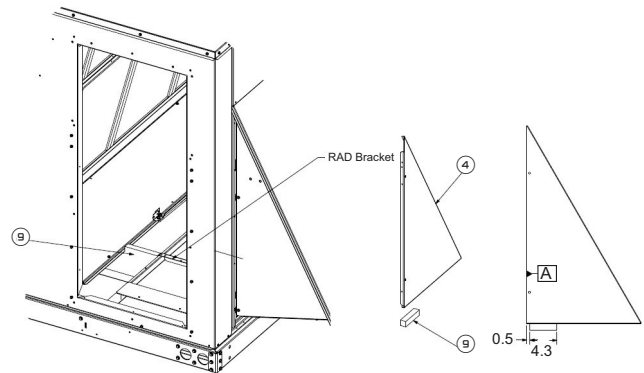

Low Leak Economizer: Align gasket so it is centered with the screw that secures the return air damper to the return opening flange. See [Figure 4](#).

Figure 4. Align gasket with RAD mounting screw

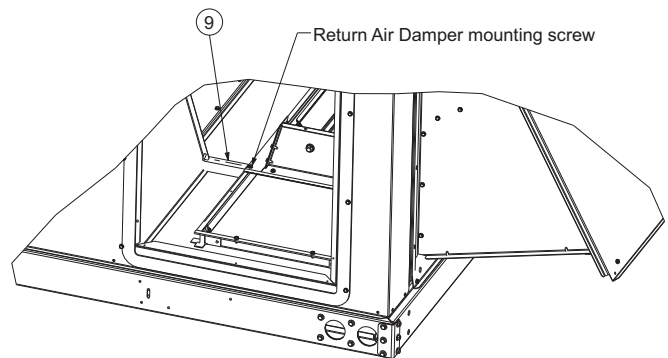

Cut one piece of gasket (9) to a length of 4.3 inch and attach to (4) leaving a gap of 0.5 inch from face A. See [Figure 3](#).

Installation

Comparative Enthalpy

Units with Standard and Low Leak Economizer Control Option

1. Install humidity and temperature sensors as required. See [Figure 5](#).

Figure 5. Install comparative enthalpy and bushing

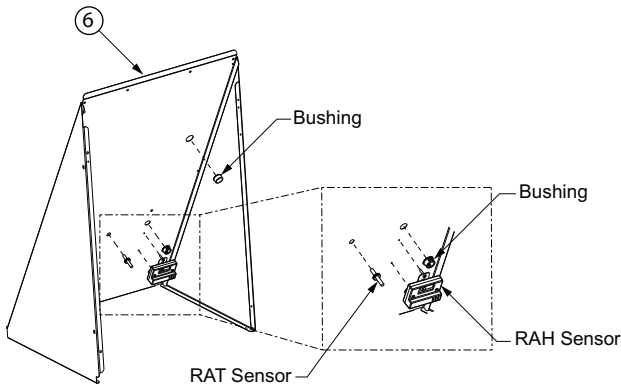

2. Install bushing in internal block-off panel. See [Figure 5](#).
3. Connect wires to humidity sensor and route wires through bushing. Wire tie leads to block-off to provide strain relief. (Wires to be routed with power exhaust leads back to the fresh air options module as described in later steps).

Differential Dry Bulb

Units with Low Leak Economizer Control Option

NOTICE

Electrostatic Discharge!

Electrostatic discharge can short equipment circuitry. Ensure that you are properly grounded before handling sensitive electronic equipment.

If differential dry bulb is installed, insert the rubber grommet to intermediate block-off panel and then assemble the return air temperature (RAT) sensors into the grommet. Connect RAT wire harness onto RAT sensor. Same as assembly of RAT for comparative enthalpy.

Figure 6. Differential dry bulb sensor

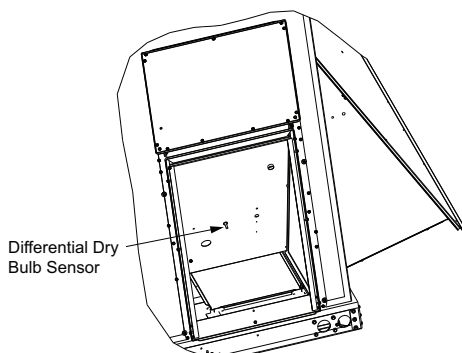

Block-Off Assembly

Note: When using the return duct opening farthest from the evaporator coil.

1. Install internal base duct block-off using two screws.

Figure 7. Install base duct block-off panel

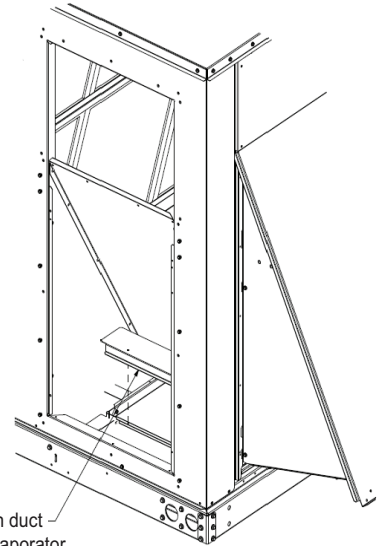

2. Attach internal block-off (4, 5 and 7) using six screws.

Figure 8. Block-off assembly

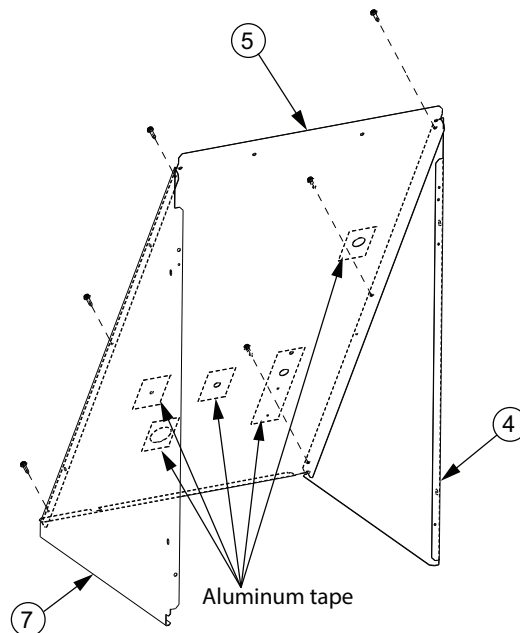

Note: The intermediate block-off panel has been made transparent for visual representation of tape. The intermediate block-off panel will be shipped with tapes covering the hole. Remove tape from the hole as per the option provided for the unit. Tape will not be visible in subsequent images.

3. Install internal block-off assembly using four screws to secure to side flanges of return opening.

Figure 9. Secure internal block-off assembly

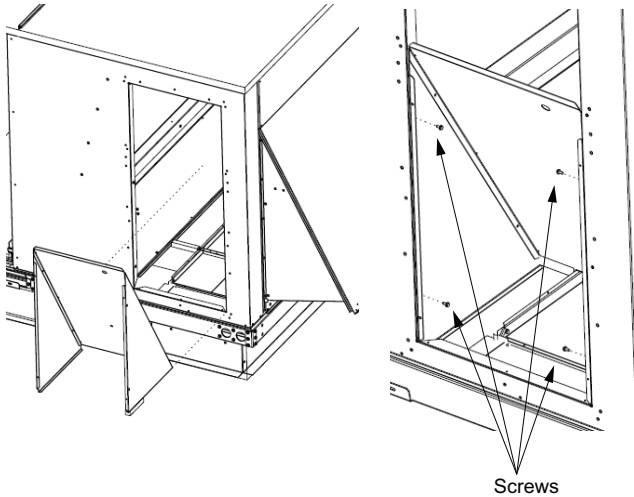

Block-Off Assembly

Note: When using the return duct opening closest to the evaporator coil.

1. Attach right and center internal block-off (4 and 5) using three screws to build right block-off assembly. Attach alternate (3) and (6) using three screws to build left block-off assembly.

Figure 10. Assemble left and right internal block-offs

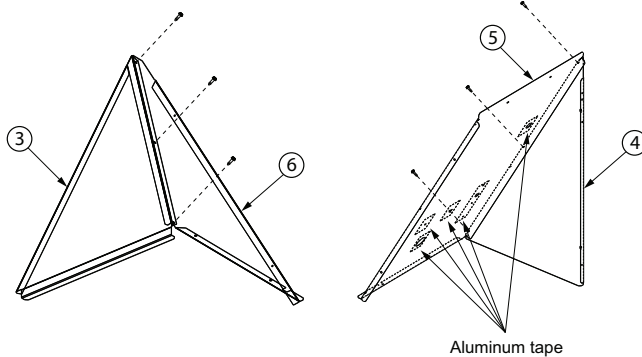

Note: The intermediate block-off panel has been made transparent for visual representation of tape. The intermediate block-off panel will be shipped with tapes covering the hole. Remove tape from the hole as per the option provided for the unit. Tape will not be visible in subsequent images.

2. Insert left internal block-off assembly - parts 3 and 6 - in unit.

Figure 11. Insert left internal block-off

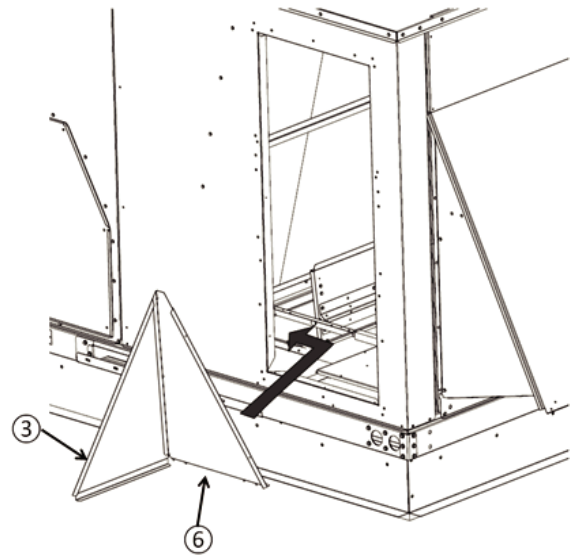

3. Secure left block-off assembly to RAD bracket for standard economizer or to the return damper flange for low leak economizer, using two screws.

Figure 12. Secure left block-off assembly

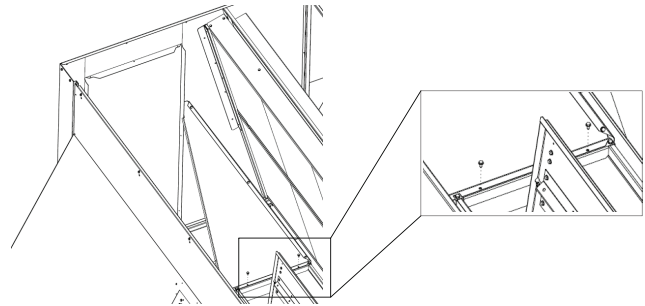

4. Using four screws, secure right block-off assembly - parts (4) and (5) - to side flanges of return opening and left blockoff assembly (6).

Figure 13. Secure right block-off assembly

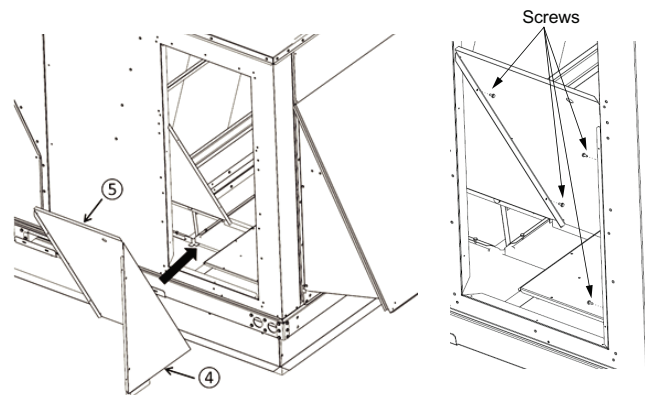

Installation

Power Exhaust Assembly

Note: Same for both return duct openings.

1. Remove center screw at bottom of rear panel duct opening.
2. Attach gasket (11) to unit back panel. Start gasket below the return horizontal duct opening, centered on the opening and aligned with the flange at the base rail. Route gasket to cover holes and dimples along sides and top of the duct opening. Gasket should be one continuous piece overlapping 1-inch at bottom center.

Figure 14. Remove screw and attach gasket

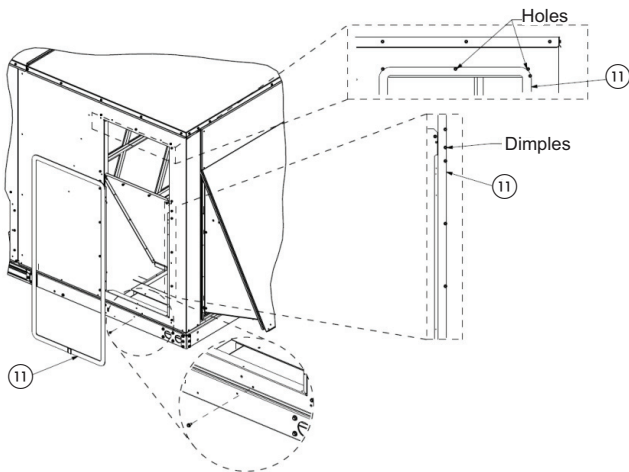

3. Install support and alignment bracket to base rail below return duct opening with three screws (1/4 x 5/8).

Figure 15. Install support and alignment bracket

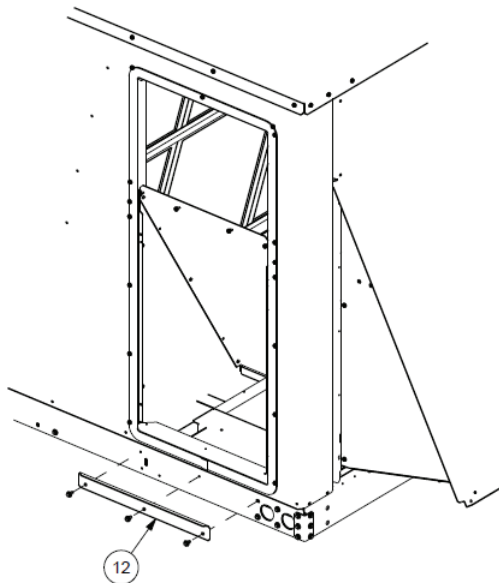

4. Set power exhaust housing adjacent to return duct opening.

5. Uncoil wires and route through grommet in internal blockoff.

Feed terminals through bushing one at a time.

Standard economizer: Insert wire tie into closest hole in the economizer support channel and secure the power and control wires. See [Figure 16](#).

Figure 16. Standard economizer wire routing

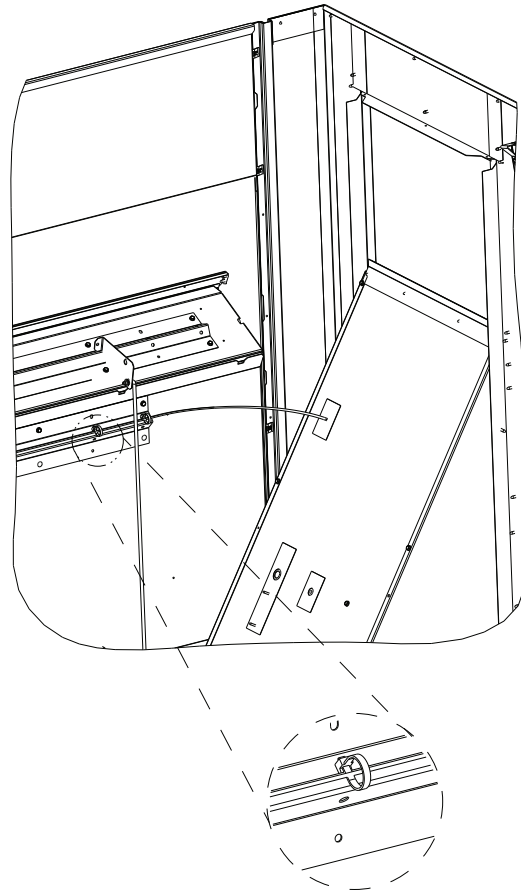

Low leak economizer: Insert wire tie into the side of the enclosure towards the top of the fresh air damper and secure the power and control wire. See [Figure 17, p. 11](#).

Figure 17. Low leak economizer wire routing

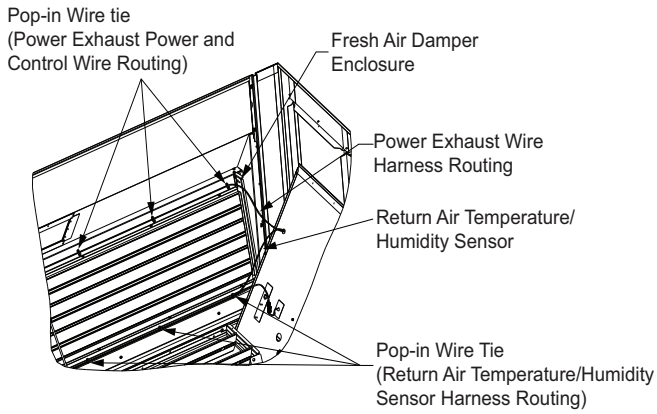

6. Attach power exhaust to side of unit using 10 screws.

Figure 18. Attach power exhaust to side of unit

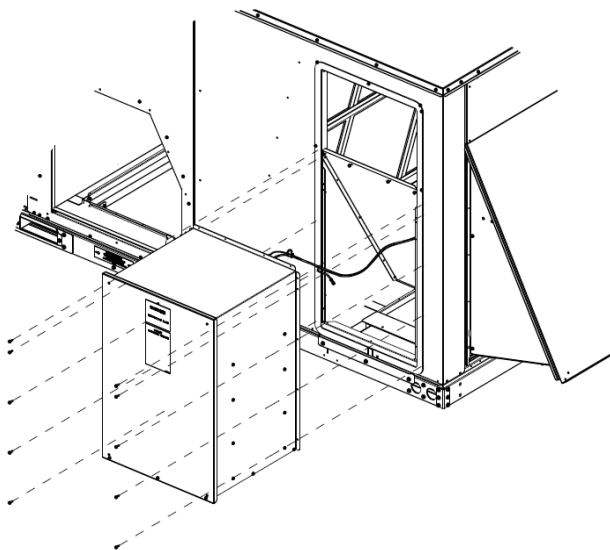

7. Using 10 screws, attach horizontal return block-off to unit rear panel.

Figure 19. Attach horizontal return block-off

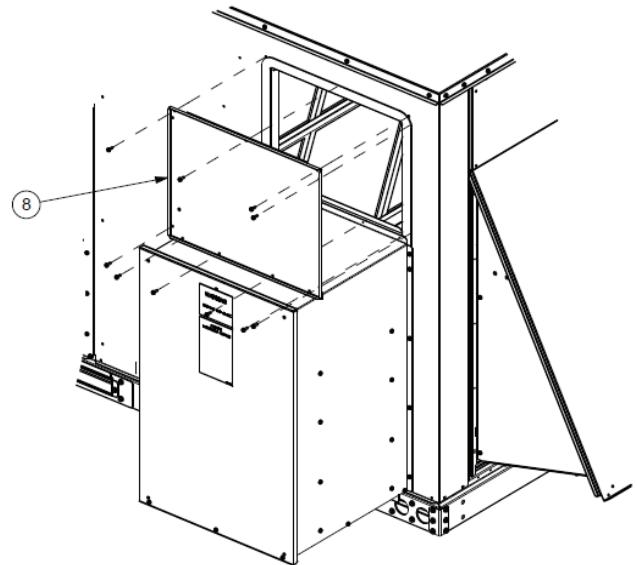

Standard economizer: Continue to route one power and one control wires (with comparative enthalpy sensor wiring if present) along economizer support channel and secure with three pop-in wire ties. See [Figure 17](#).

Figure 20. Route wires along standard economizer support bracket

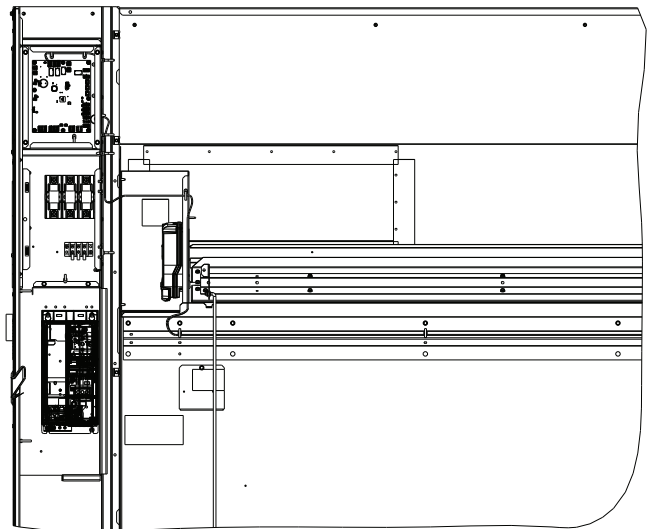

Low leak economizer: Remove tape covering pop-in wire tie holes in the top center block-off panel and insert provided pop-in wire ties. Continue to route one power and one control wires down the top center block-off panel and secure wires with the four pop-in wire ties. See [Figure 21, p. 12](#).

Installation

Figure 21. Route wires along economizer support bracket

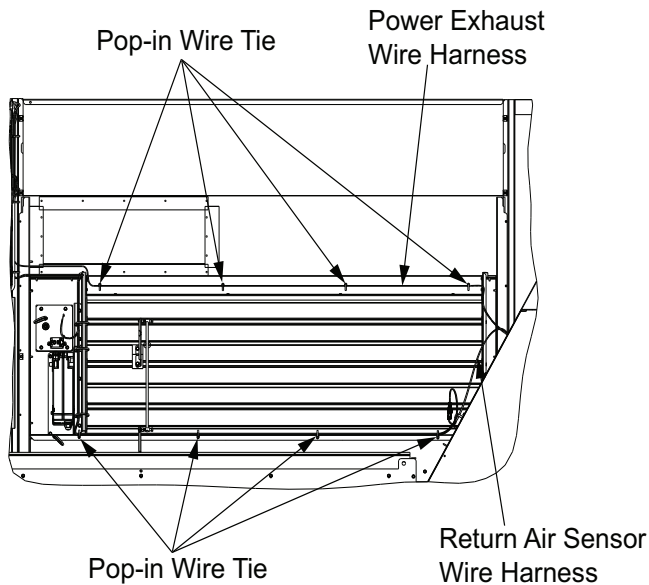
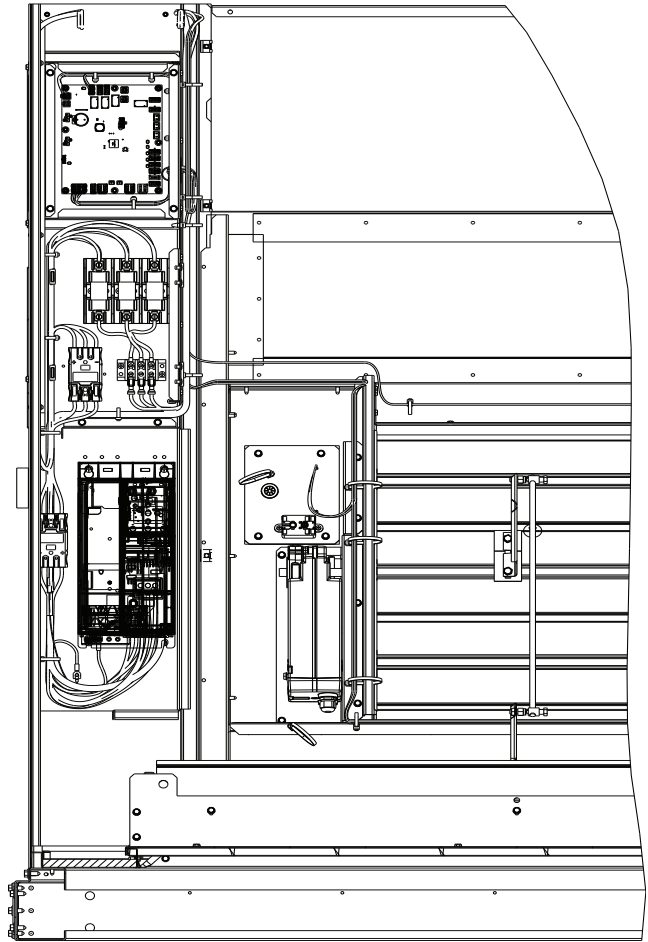

Figure 22. Power connection to VFTB1 for units with VFD



Wiring Installation

⚠ WARNING

Hazardous Voltage w/Capacitors!

Failure to disconnect power and discharge capacitors before servicing could result in death or serious injury. Disconnect all electric power, including remote disconnects and discharge all motor start/run capacitors before servicing. Follow proper lockout/tagout procedures to ensure the power cannot be inadvertently energized. Verify with a CAT III or IV voltmeter rated per NFPA 70E that all capacitors have discharged.

Important: Use provided wire ties to make sure wires are secured and protected from sharp edges, rotating parts, and hot surfaces.

Power Wiring

1. On units with a factory installed variable frequency drive (VFD), route the long, dual, high-voltage wires to the VFTB1 located inside the VFD panel (see [Figure 22](#)).
2. Confirm that all wires are protected from damage by moving parts. Secure the wires with wire ties (provided).
3. After installation is complete, the Symbio™ 700 UC configuration will need to be updated to enable this installed feature.

Control Wiring

Units with Standard and Low Leak Economizer

Note: Refer to [Figure 23, p. 13](#) for connections.

Connect power exhaust wire connector J6 to P6 on the fresh air options module in the return control box (brown connector).

1. Route controls wiring (black and red wires) and connector J6.
2. Connect wire connector J6 to P6 on the fresh air options module in the return control box (brown connector). Secure wiring with pop-in wire ties.
3. After installation is complete, the Symbio™ 700 UC configuration will need to be updated to enable this installed feature.

Figure 23. Control wiring diagram

POWER WIRING

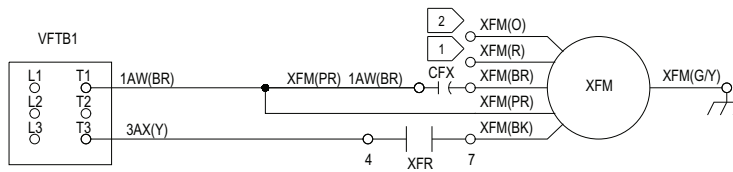

REF DES	DESCRIPTION
VFTB1	TERMINAL BLOCK
CFX	XFM CAPACITOR
XFM	EXHAUST FAN MOTOR
XFR	EXHAUST FAN RELAY
FAOM	FRESH AIR MODULE

WIRE COLOR ABBREVIATION CODES			
CODE	COLOR	CODE	COLOR
BK	BLACK	PK	PINK
BL	BLUE	R	RED
BR	BROWN	TQ	TURQUOISE
G	GREEN	V,(PR)	PURPLE
GY	GREY	W	WHITE
O	ORANGE	Y	YELLOW

CONTROL WIRING

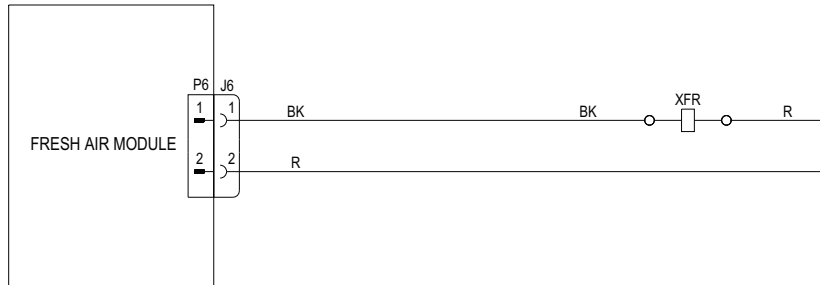

NOTE:

- 1 MOTOR LEAD WIRE XFM-R IS UNUSED AND ISOLATED.
- 2 MOTOR LEAD WIRE XFM-O IS ABSENT IN 230V MOTORS AND THIS IS KEPT UNUSED AND ISOLATED IN 460-575V.

Unit Power Exhaust Operation and Settings

Standard Economizer

The power exhaust setpoint (point at which the power exhaust is turned on) is adjustable from 0% to 100% economizer damper outside air setting, corresponding to the setting of the exhaust setpoint potentiometer on the RTEM-EM. The power exhaust is turned on when the indoor blower is running and the damper position is greater than the power exhaust setpoint. See.

Low Leak Economizer

The power exhaust setpoint (point at which the power exhaust is turned on) is adjustable from 0% to 100% economizer damper outside air setting, corresponding to the setting of the EXH1 SET value in the SETPOINTS menu in the JADE controller. With 2-speed fan units EXH1 L (low speed fan) and EXH1 H (high speed fan) settings are required. See.

The JADE display will display EXH1 OUT as ON when the power exhaust is turned on. Power exhaust is turned on when the damper position is greater than the power exhaust setpoint.

Final Installation Steps

1. Replace supply fan access panel.
2. Replace filter access panel.
3. Close unit disconnect, then place the thermostat fan selector in the Fan **ON** position, and the Heat/Cool selector in the **OFF** position. This places the damper in the minimum ventilation position.

Trane and American Standard create comfortable, energy efficient indoor environments for commercial and residential applications. For more information, please visit trane.com or americanstandardair.com.

Trane and American Standard have a policy of continuous product and product data improvement and reserve the right to change design and specifications without notice. We are committed to using environmentally conscious print practices.