

Installation Instructions

0 to 100% Downflow Dry Bulb Economizer

Foundation™ Packaged Cooling and
Gas/Electric
15 to 25 Tons

Model Number:
BAYECON302*

Used With:
E/GDK180-300

SAFETY WARNING

Only qualified personnel should install and service the equipment. The installation, starting up, and servicing of heating, ventilating, and air-conditioning equipment can be hazardous and requires specific knowledge and training. Improperly installed, adjusted or altered equipment by an unqualified person could result in death or serious injury. When working on the equipment, observe all precautions in the literature and on the tags, stickers, and labels that are attached to the equipment.

Introduction

Read this manual thoroughly before operating or servicing this unit.

Warnings, Cautions, and Notices

Safety advisories appear throughout this manual as required. Your personal safety and the proper operation of this machine depend upon the strict observance of these precautions.

The three types of advisories are defined as follows:

- ⚠ WARNING** Indicates a potentially hazardous situation which, if not avoided, could result in death or serious injury.
- ⚠ CAUTION** Indicates a potentially hazardous situation which, if not avoided, could result in minor or moderate injury. It could also be used to alert against unsafe practices.
- NOTICE** Indicates a situation that could result in equipment or property-damage only accidents.

Important Environmental Concerns

Scientific research has shown that certain man-made chemicals can affect the earth's naturally occurring stratospheric ozone layer when released to the atmosphere. In particular, several of the identified chemicals that may affect the ozone layer are refrigerants that contain Chlorine, Fluorine and Carbon (CFCs) and those containing Hydrogen, Chlorine, Fluorine and Carbon (HCFCs). Not all refrigerants containing these compounds have the same potential impact to the environment. Trane advocates the responsible handling of all refrigerants.

Important Responsible Refrigerant Practices

Trane believes that responsible refrigerant practices are important to the environment, our customers, and the air conditioning industry. All technicians who handle refrigerants must be certified according to local rules. For the USA, the Federal Clean Air Act (Section 608) sets forth the requirements for handling, reclaiming, recovering and recycling of certain refrigerants and the equipment that is used in these service procedures. In addition, some states or municipalities may have additional requirements that must also be adhered to for responsible management of refrigerants. Know the applicable laws and follow them.

⚠ WARNING

Proper Field Wiring and Grounding Required!

Failure to follow code could result in death or serious injury. All field wiring **MUST** be performed by qualified personnel. Improperly installed and grounded field wiring poses **FIRE** and **ELECTROCUTION** hazards. To avoid these hazards, you **MUST** follow requirements for field wiring installation and grounding as described in **NEC** and your local/state/national electrical codes.

⚠ WARNING

Personal Protective Equipment (PPE) Required!

Failure to wear proper PPE for the job being undertaken could result in death or serious injury. Technicians, in order to protect themselves from potential electrical, mechanical, and chemical hazards, **MUST** follow precautions in this manual and on the tags, stickers, and labels, as well as the instructions below:

- Before installing/servicing this unit, technicians **MUST** put on all PPE required for the work being undertaken (Examples; cut resistant gloves/sleeves, butyl gloves, safety glasses, hard hat/bump cap, fall protection, electrical PPE and arc flash clothing). **ALWAYS** refer to appropriate Safety Data Sheets (SDS) and OSHA guidelines for proper PPE.
- When working with or around hazardous chemicals, **ALWAYS** refer to the appropriate SDS and OSHA/GHS (Global Harmonized System of Classification and Labeling of Chemicals) guidelines for information on allowable personal exposure levels, proper respiratory protection and handling instructions.
- If there is a risk of energized electrical contact, arc, or flash, technicians **MUST** put on all PPE in accordance with OSHA, NFPA 70E, or other country-specific requirements for arc flash protection, **PRIOR** to servicing the unit. **NEVER PERFORM ANY SWITCHING, DISCONNECTING, OR VOLTAGE TESTING WITHOUT PROPER ELECTRICAL PPE AND ARC FLASH CLOTHING. ENSURE ELECTRICAL METERS AND EQUIPMENT ARE PROPERLY RATED FOR INTENDED VOLTAGE.**

⚠ WARNING

Follow EHS Policies!

Failure to follow instructions below could result in death or serious injury.

- All Trane personnel must follow the company’s Environmental, Health and Safety (EHS) policies when performing work such as hot work, electrical, fall protection, lockout/tagout, refrigerant handling, etc. Where local regulations are more stringent than these policies, those regulations supersede these policies.
- Non-Trane personnel should always follow local regulations.

⚠ WARNING

R-454B Flammable A2L Refrigerant!

Failure to use proper equipment or components as described below could result in equipment failure, and possibly fire, which could result in death, serious injury, or equipment damage.

The equipment described in this manual uses R-454B refrigerant which is flammable (A2L). Use ONLY R-454B rated service equipment and components. For specific handling concerns with R-454B, contact your local representative.

Copyright

This document and the information in it are the property of Trane, and may not be used or reproduced in whole or in part without written permission. Trane reserves the right to revise this publication at any time, and to make changes to its content without obligation to notify any person of such revision or change.

Trademarks

All trademarks referenced in this document are the trademarks of their respective owners.

Table of Contents

General Information	5
Inspection	5
Parts List	5
Field Installed Option	5
Factory Installed Option	5
Field Supplied Part	5
Installation	6
Field Installed Option	6
Trane Configuration	6
Carrier Configuration	7
Applicable to both Trane and Carrier Configurations	7
Factory Installed Option (Field Setup)	9
Trane Configuration	9
Carrier Configuration	10
Mist Eliminator Servicing	11
Minimum Position Setting	12
Dry Bulb Settings	12
Reference Enthalpy Settings	12
Wiring Connections	12

General Information

Inspection

1. Unpack all components of the kit.
2. Check carefully for shipping damage. If any damage is found, report it immediately, and file a claim against the transportation company.

Parts List

Field Installed Option

Figure 1. Major economizer components

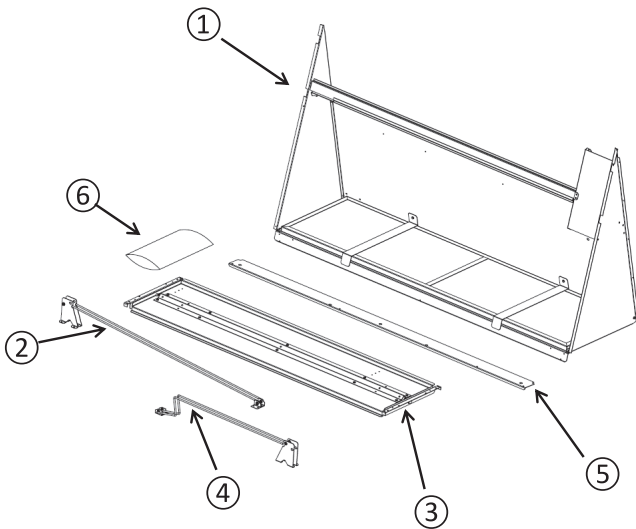

Table 1. Major economizer component parts list

Item	Description	Qty
1	Outside air damper assembly	1
2	Connecting rod assembly (Carrier configuration)	1
3	Return air damper assembly	1
4	Connecting rod assembly (Trane option)	1
5	Block-off	1
6	Plastic bag of miscellaneous parts:	1
	Screws	-
	Edge protector	2
	Installation Instructions	1

Note: Verify that all of the parts are available for installation.

Factory Installed Option

Table 2. Factory installed component parts list

Qty	Description
1	Block-off
1	Plastic bag containing screws

Field Supplied Part

NOTICE	
Corrosion Damage!	
Failure to use recommended caulking/sealant could cause corrosion related failures to refrigerant components.	

Table 3. Field supplied parts list

Qty	Description
1	Tube Sealant - Trane recommends Sikaflex 221 (SEL00439)

Figure 2. Economizer damper blade

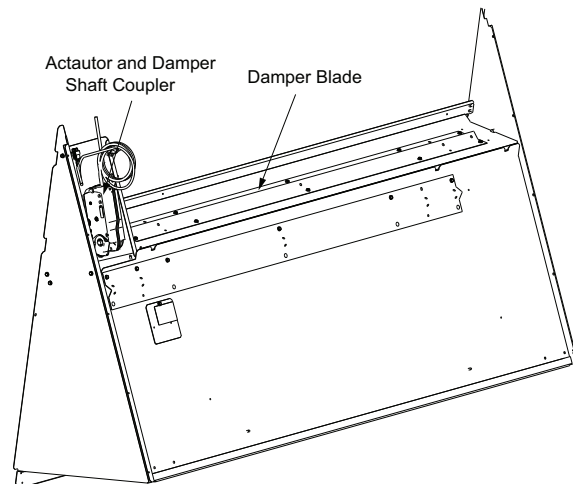

Installation

⚠ WARNING

Hazardous Service Procedures!

Failure to follow all precautions in this manual and on the tags, stickers, and labels could result in death or serious injury.

Technicians, in order to protect themselves from potential electrical, mechanical, and chemical hazards, **MUST** follow precautions in this manual and on the tags, stickers, and labels, as well as the following instructions: Unless specified otherwise, disconnect all electrical power including remote disconnect and discharge all energy storing devices such as capacitors before servicing. Follow proper lockout/tagout procedures to ensure the power can not be inadvertently energized. When necessary to work with live electrical components, have a qualified licensed electrician or other individual who has been trained in handling live electrical components perform these tasks.

Important:

- If the unit is in a Trane airflow configuration, proceed to “Trane Configuration,” p. 6.
- If the unit is in a Carrier airflow configuration, proceed to “Carrier Configuration,” p. 7.

Field Installed Option

⚠ WARNING

Hazardous Voltage with Capacitors!

Failure to disconnect power and discharge capacitors before servicing could result in death or serious injury. Disconnect all electric power, including remote disconnects and discharge all motor start/run capacitors before servicing. Follow proper lockout/tagout procedures to ensure the power cannot be inadvertently energized. Verify with a CAT III or IV voltmeter rated per NFPA 70E that all capacitors have discharged.

Trane Configuration

1. Assemble connecting rods (4) to return air damper (3) by aligning holes (1) and (2), and attach rods using two screws. See Figure 3. See Figure 1 for part identification.

Figure 3. Assemble connecting rods (Trane)

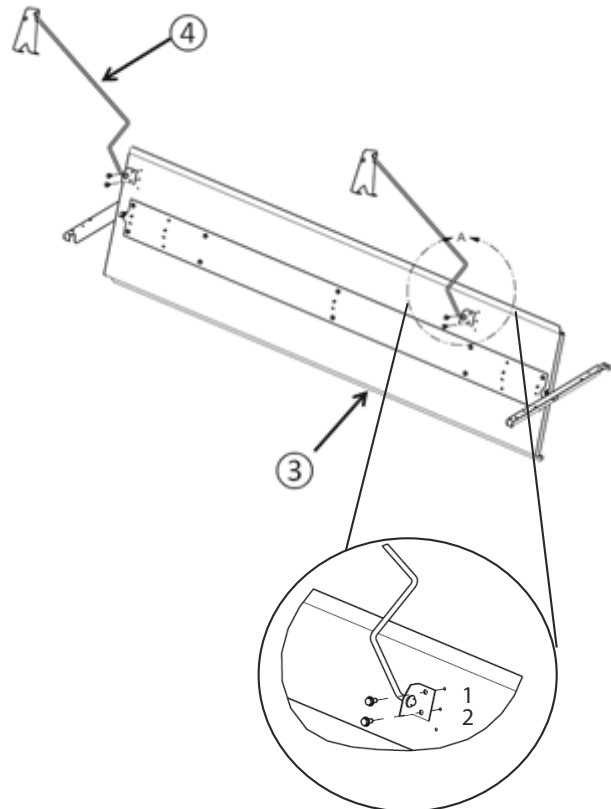

2. Remove the filter/fan compartment access panel and the unit end panel (evaporator end). See Figure 4.

Figure 4. Remove panels

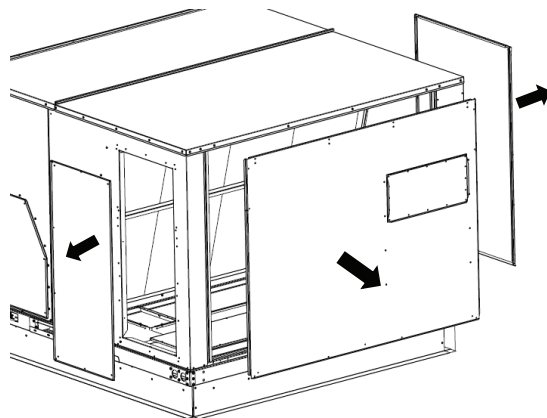

3. Place the return air damper assembly into the return air opening as illustrated in Figure 5. Ensure the damper is positioned with the sheet metal lip in the upward position.
4. Attach the pivotal brackets to the unit using two screws per bracket.

5. Raise the damper and rods into the vertical position. Tie the connecting rods to the filter rack to prevent them from interfering with the economizer. See [Figure 5](#).
6. Ensure damper is positioned with sheet metal lip in the upward position as illustrated in [Figure 5](#).

Figure 5. Install return air damper assembly (Trane)

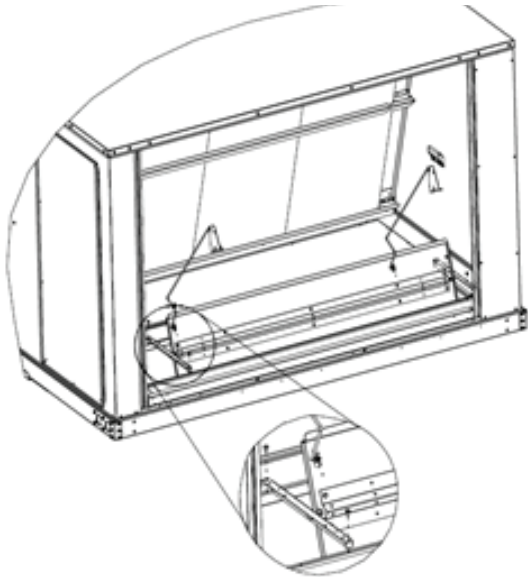

Carrier Configuration

1. Assemble connecting rods (2) to return air damper (3) by aligning holes 2 and 3, and attach rods using two screws on each side. See [Figure 6](#).

Figure 6. Assemble connecting rods (Carrier)

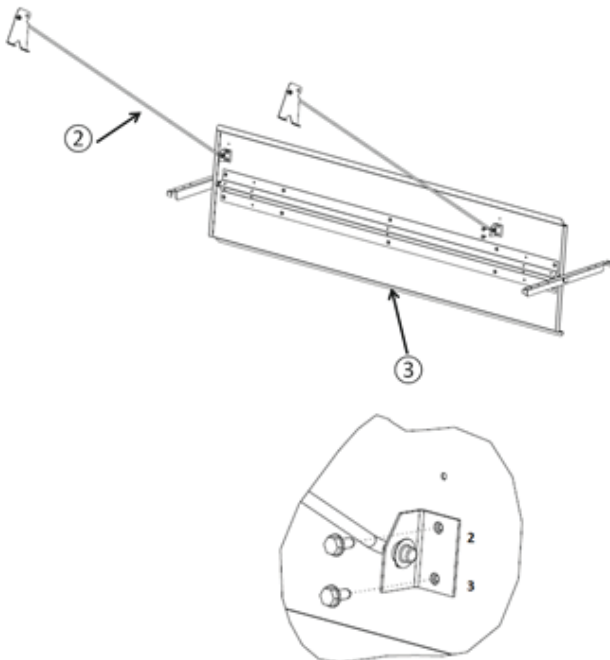

2. Remove the filter/fan compartment access panel and the unit end panel (evaporator end). See [Figure 4](#).
3. Place the return air damper assembly into the return air opening as illustrated in [Figure 7](#). Ensure the damper is positioned with the sheet metal lip in the upward position.
4. Attach the pivotal brackets to the unit using two screws per bracket.
5. Raise the damper and rods into the vertical position. Tie the connecting rods to the filter rack to prevent them from interfering with the economizer, as illustrated in [Figure 7](#).
6. Ensure damper is positioned with sheet metal lip in the upward position, as illustrated in [Figure 7](#).

Figure 7. Install return air damper assembly (Carrier)

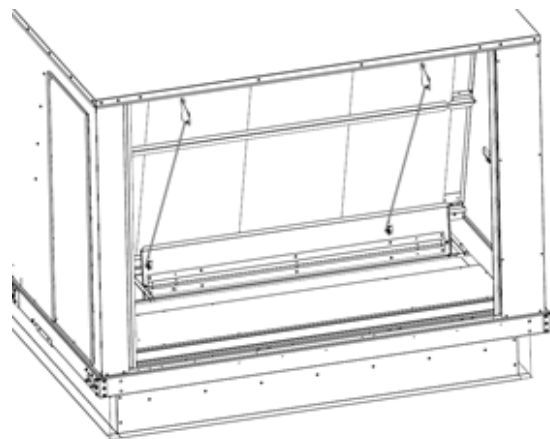

Applicable to both Trane and Carrier Configurations

Note: Before proceeding, confirm previous Trane or Carrier step..

1. Attach block-off (5) to unit using four screws shown in [Figure 8](#).

The block-off is designed to close the opening created between the economizer and the base, when the economizer assembly is installed in the operating position.

Figure 8. Install block-off

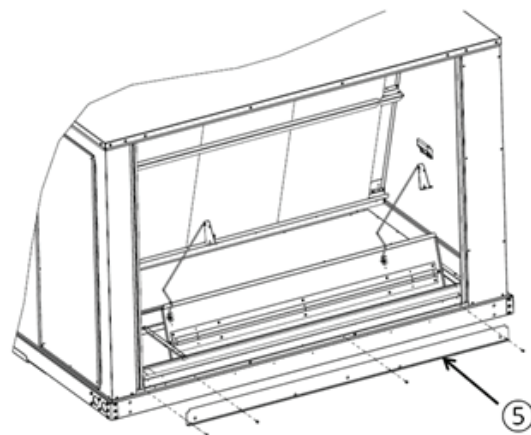

Installation

- Remove approximately 3-inch of gasket material from the bottom of each corner post to expose the holes used to attach the economizer assembly to the unit shown in [Figure 9](#), detail A.

Note: There are two holes, a (large) clearance hole and a (small) engagement hole. Their function will be discussed later.

Figure 9. Remove gasket material

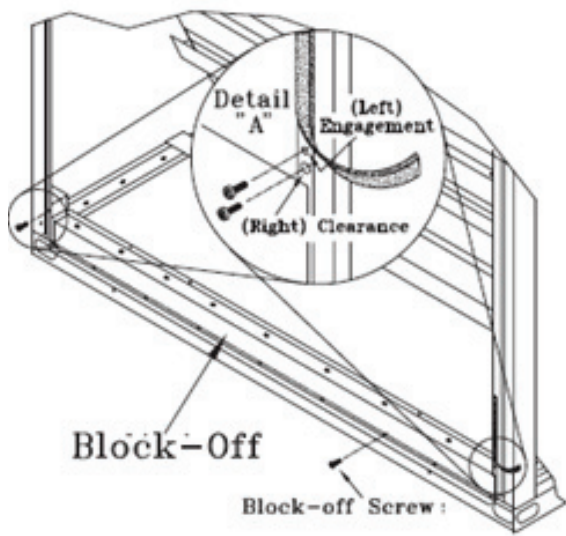

- Place the economizer assembly into the opening with the back right flange, on the economizer, behind the corner post flange. See [Figure 10](#).

Figure 10. Install economizer assembly

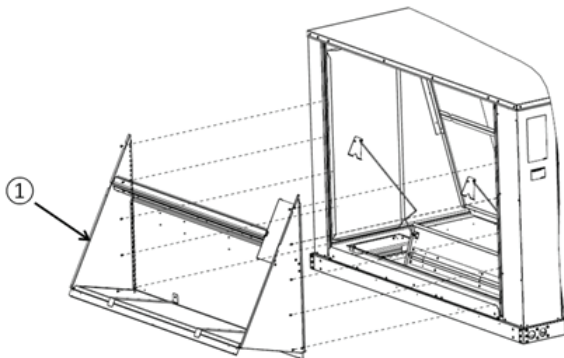

- Position the left side flange on the economizer in front of the corner post flange.
- With the screws provided, secure the bottom right hand side of the economizer assembly by inserting the screws through the clearance holes in the corner post and into the engagement holes in the economizer assembly. Refer to [Figure 10](#).
- Secure the bottom left hand side of the economizer assembly by inserting the screws through the clearance holes in the economizer assembly and into the engagement holes of the corner post. Refer to [Figure 10](#).

- Secure economizer using five screws on left side and five screws on right side. See [Figure 10](#).
- Attach connecting rod bracket to outdoor damper blade using two screws on each side. See [Figure 11](#), detail B.
- Check for binding by slowly operating the dampers by hand. See [Figure 2](#).

Figure 11. Attach connecting rod bracket

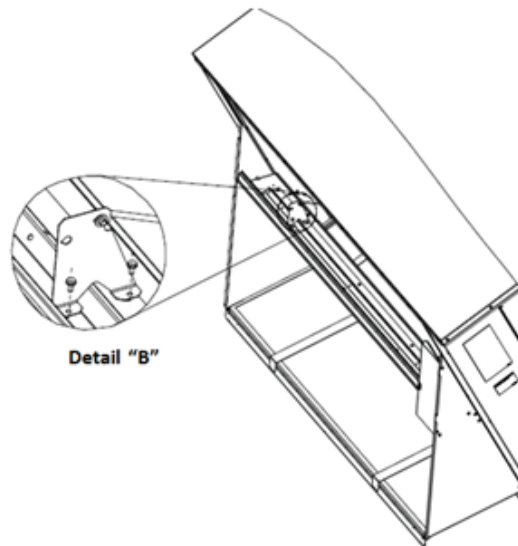

- Attach end panel back to unit and seal along indicated areas in [Figure 12](#) with field supplied silicone sealant.

Figure 12. Attach end panel

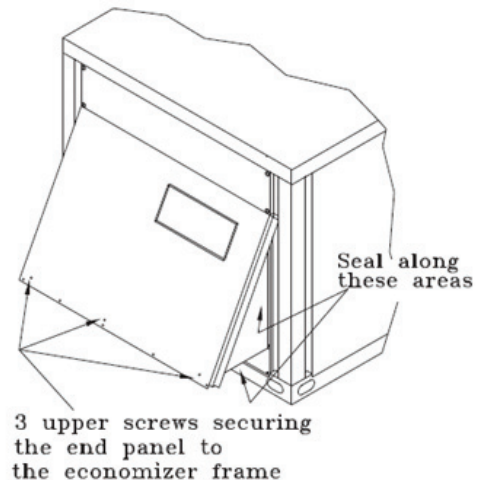

Factory Installed Option (Field Setup)

⚠ WARNING

Hazardous Voltage with Capacitors!

Failure to disconnect power and discharge capacitors before servicing could result in death or serious injury. Disconnect all electric power, including remote disconnects and discharge all motor start/run capacitors before servicing. Follow proper lockout/tagout procedures to ensure the power cannot be inadvertently energized. Verify with a CAT III or IV voltmeter rated per NFPA 70E that all capacitors have discharged.

Each economizer ships inside the unit and requires partial assembling and setup in the field.

Trane Configuration

1. Remove the filter/fan compartment access panel.
2. Remove the lower screws and block off angle in the end panel. See [Figure 13](#). Lay block-off angle aside for later installation.

Figure 13. Pull economizer assembly outward

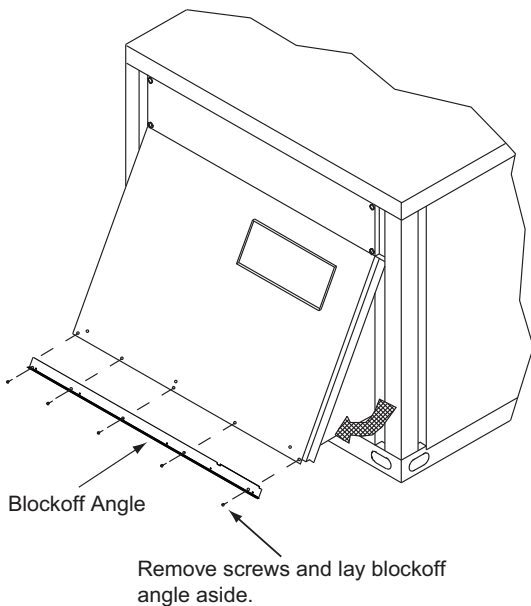

3. Do not remove the screws in the upper row of the end panel.
4. Grasp the bottom of the end panel and pull the economizer assembly outward into the operating position. See [Figure 13](#).
5. Remove approximately 3-inch of gasket material from the bottom of each corner post to expose the holes used to attach the economizer assembly to the unit. See [Figure 14](#).

6. With the screws provided, secure each side of the economizer assembly by inserting a screw through the clearance hole in the bottom of the corner post and into the engagement hole in the economizer assembly. See [Figure 14](#).

Figure 14. Remove gasket material

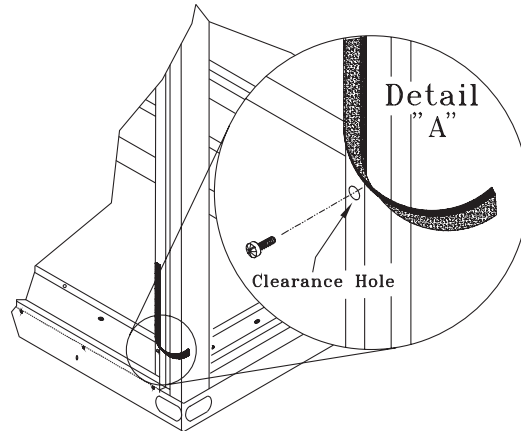

7. Install the block-off angle underneath the economizer. See [Figure 15](#). The block-off angle is designed to close the opening created between the economizer and the base when the economizer assembly is in its operating position.
 - a. Holding the block-off angle with the holes at the bottom and the bottom angle outward, tilt the top forward and insert it into the opening between the economizer and the unit base.
 - b. Press the bottom of the block-off angle against the unit and line up the holes. Using the provided screws, secure it into place.

Figure 15. Block-off installation

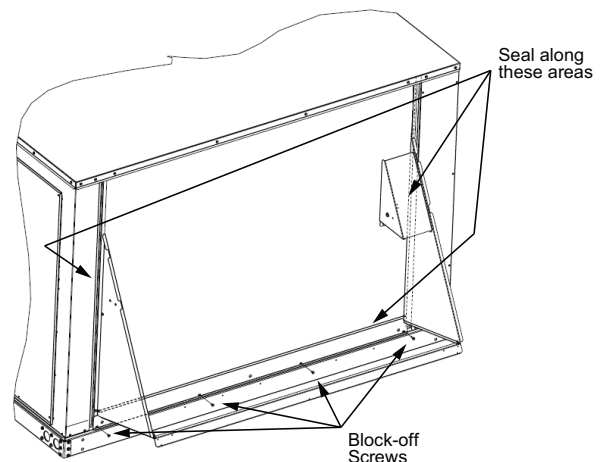

Installation

Carrier Configuration

1. Remove filter and rear access panel.
2. Remove return duct cover (7) from Carrier return air opening. See [Figure 16](#).

Figure 16. Remove duct cover

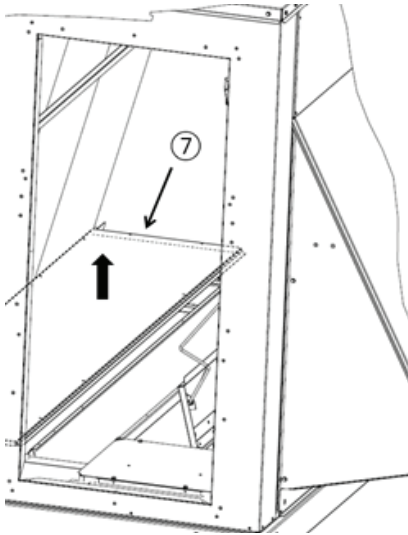

3. Remove block-off (8) from return air opening. See [Figure 17](#).

Figure 17. Remove block-off

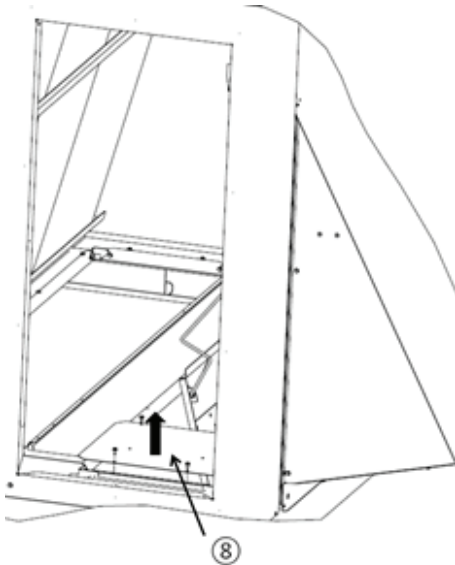

4. Remove Trane connecting rods (4) from the unit. See [Figure 18](#).

Figure 18. Remove connecting rods

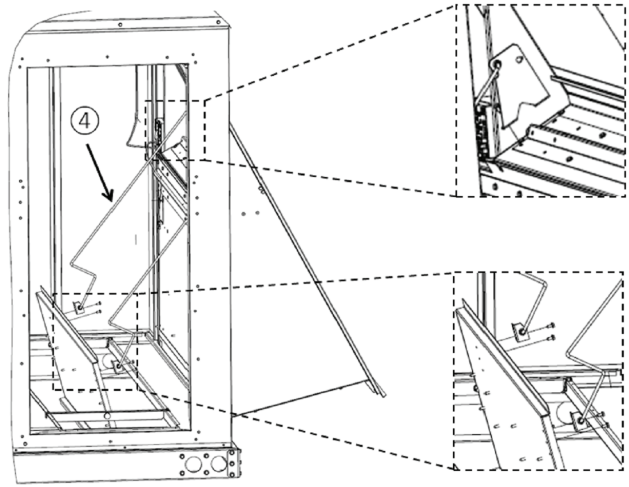

5. Switch return air damper assembly (3) from the Trane position to the Carrier position and secure with screws on both ends. See [Figure 19](#).

Figure 19. Switch return air assembly from Trane to Carrier

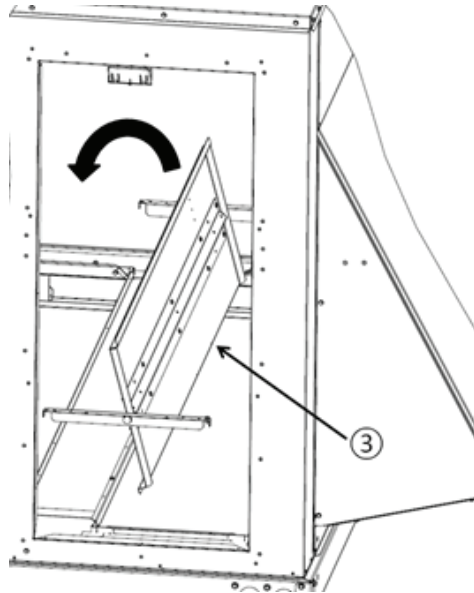

6. Attach connecting rods (2) to return air damper and outdoor damper. See [Figure 20](#).

Figure 20. Attach connecting rods

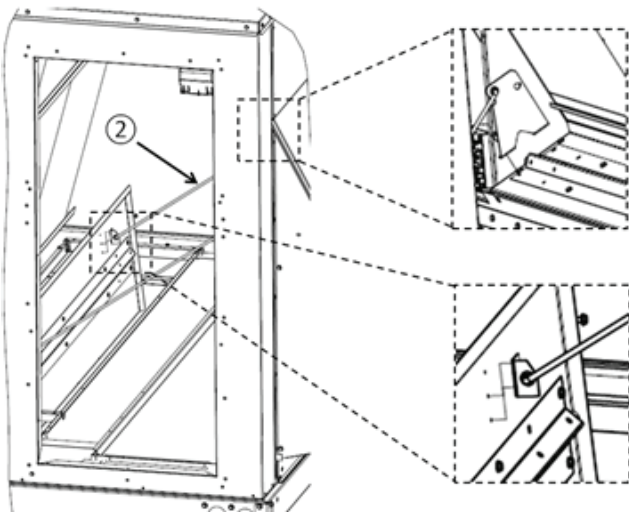

7. Attach return duct cover (7) to Trane return air inlet. See [Figure 21](#).

Figure 21. Attach return duct cover

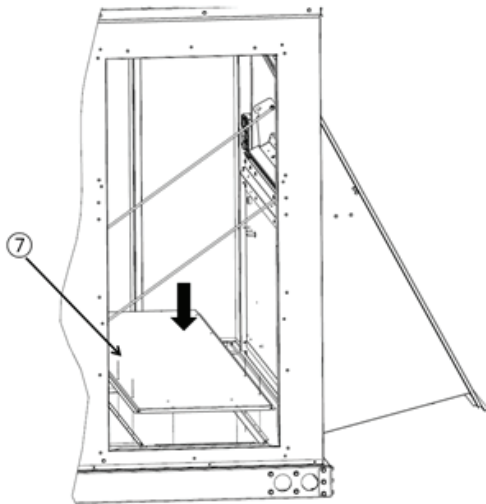

8. If barometric or power exhaust is not installed, attach block-off plate (8) to Carrier return air inlet. See [Figure 22](#).

Figure 22. Attach block-off plate

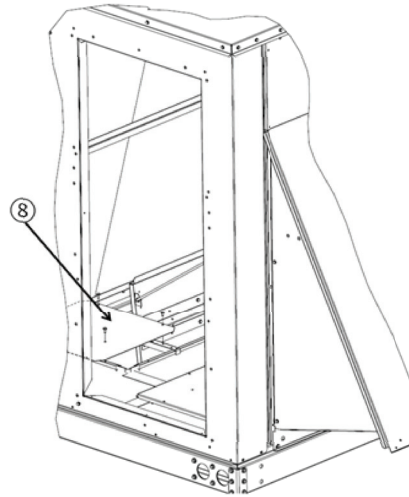

9. Attach Filter and Rear access panels.

Mist Eliminator Servicing

1. Remove screws from end panel securing it to the unit and economizer.
2. Set end panel aside.
3. Remove mist eliminator brackets.
4. Remove mist eliminators and clean.
5. Reinstall and secure the mist eliminator brackets.
6. Reinstall end panel and secure to unit and economizer.

Figure 23. Mist eliminator removal

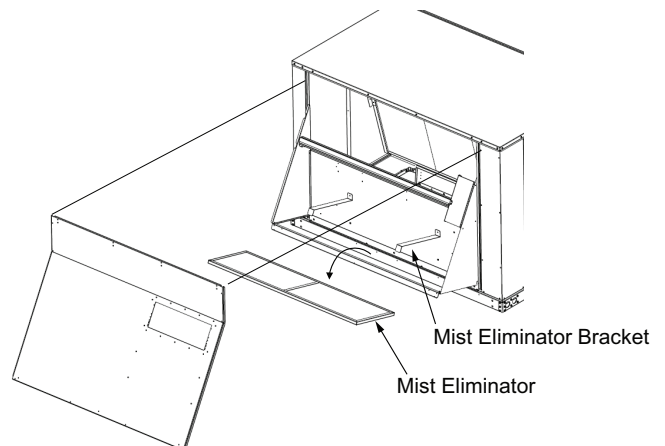

Installation

Minimum Position Setting

To adjust the minimum position setting and check out the economizer, the power must be connected.

1. Close the unit disconnect and place the zone sensor fan selector in the fan **ON** position and the heat/cool selector in the **OFF** position. This will place the damper in the minimum ventilation position.
2. To adjust the minimum position setting for the required ventilation air, use the Symbio™ service and installation mobile app or Symbio 700 on-board UI to adjust the economizer minimum position setpoint BAS in the fresh/return air settings menu. The damper will open to this setting each time the blower circuit is energized.

When adjusting minimum position, the damper may move to the new setting in several small steps. Once the damper has remained in position for 10 to 15 seconds without movement, it can be assumed it is at the new position.

3. Replace the filter access panel.

The damper will close when the blower circuit is de-energized.

Dry Bulb Settings

Standard economizer dry bulb changeover is field selectable and has a range of 50°F to 140°F.

Reference Enthalpy Settings

Economizer enthalpy changeover is field selectable and has a range of 50°F to 140°F. The default is 60°F. This selection can be made using the Symbio service and installation mobile app or Symbio™ 700 on-board UI.

Table 4. Economizer control options

Control Option	Enable Conditions	Optional Sensors Required
Comparative Enthalpy	Outside Air Enthalpy < Return Air Enthalpy – Econ Enthalpy Offset and Outside Air Temperature < Economizer Drybulb Setpoint – Econ DryBulb Offset	Outdoor Air Temperature Sensor Outdoor Air Humidity Sensor Return Air Temperature Sensor Return Air Humidity Sensor
Reference Enthalpy	Outside Air Enthalpy < Reference Enthalpy Setpoint – Econ Enthalpy Offset and Outside Air Temperature < Economizer Drybulb Setpoint - Econ DryBulb Offset	Outdoor Air Temperature Sensor Outdoor Air Humidity Sensor
Dry Bulb	OA Temp < [Economizer Outdoor Air Enable Setpoint BAS - Economizer Dry Bulb Enable Offset]	Outdoor Air Temperature Sensor
Differential Dry Bulb	OA Temp < RA Temp - Economizer Dry Bulb Enable Offset - Economizer Dry Bulb Disable Return Air Offset	Outdoor Air Temperature Sensor Return Air Temperature Sensor

Wiring Connections

Refer to main unit schematic for electrical connections to Fresh air module located in return section control box, See [Figure 24](#).

After installation is complete, the Symbio™ 700 UC configuration will need to be updated to enable this installed feature. Refer to Symbio Applications Guide.

Figure 24. Fresh air options module location



Notes

Trane and American Standard create comfortable, energy efficient indoor environments for commercial and residential applications. For more information, please visit trane.com or americanstandardair.com.

Trane and American Standard have a policy of continuous product and product data improvement and reserve the right to change design and specifications without notice. We are committed to using environmentally conscious print practices.