

Installation Instructions

Barometric Relief Damper

Precedent™ Packaged Rooftop Units

12.5 to 25 Tons

Model Number: FIABARM003* **Used With:** Precedent D cabinet (Digit 39 = D)

▲ SAFETY WARNING

Only qualified personnel should install and service the equipment. The installation, starting up, and servicing of heating, ventilating, and air-conditioning equipment can be hazardous and requires specific knowledge and training. Improperly installed, adjusted or altered equipment by an unqualified person could result in death or serious injury. When working on the equipment, observe all precautions in the literature and on the tags, stickers, and labels that are attached to the equipment.

September 2024

ACC-SVN286A-EN

Introduction

Read this manual thoroughly before operating or servicing this unit.

Warnings, Cautions, and Notices

Safety advisories appear throughout this manual as required. Your personal safety and the proper operation of this machine depend upon the strict observance of these precautions.

The three types of advisories are defined as follows:



Indicates a potentially hazardous situation which, if not avoided, could result in death or serious injury.



Indicates a potentially hazardous situation which, if not avoided, could result in minor or moderate injury. It could also be used to alert against unsafe practices.

NOTICE

Indicates a situation that could result in equipment or property-damage only accidents.

Important Environmental Concerns

Scientific research has shown that certain man-made chemicals can affect the earth's naturally occurring stratospheric ozone layer when released to the atmosphere. In particular, several of the identified chemicals that may affect the ozone layer are refrigerants that contain Chlorine, Fluorine and Carbon (CFCs) and those containing Hydrogen, Chlorine, Fluorine and Carbon (HCFCs). Not all refrigerants containing these compounds have the same potential impact to the environment. Trane advocates the responsible handling of all refrigerants.

Important Responsible Refrigerant Practices

Trane believes that responsible refrigerant practices are important to the environment, our customers, and the air conditioning industry. All technicians who handle refrigerants must be certified according to local rules. For the USA, the Federal Clean Air Act (Section 608) sets forth the requirements for handling, reclaiming, recovering and recycling of certain refrigerants and the equipment that is used in these service procedures. In addition, some states or municipalities may have additional requirements that must also be adhered to for responsible management of refrigerants. Know the applicable laws and follow them.

WARNING

Proper Field Wiring and Grounding Required!

Failure to follow code could result in death or serious injury.

All field wiring MUST be performed by qualified personnel. Improperly installed and grounded field wiring poses FIRE and ELECTROCUTION hazards. To avoid these hazards, you MUST follow requirements for field wiring installation and grounding as described in NEC and your local/state/national electrical codes.

WARNING

Personal Protective Equipment (PPE) Required!

Failure to wear proper PPE for the job being undertaken could result in death or serious injury.

Technicians, in order to protect themselves from potential electrical, mechanical, and chemical hazards, **MUST** follow precautions in this manual and on the tags, stickers, and labels, as well as the instructions below:

- **Before installing/servicing this unit, technicians MUST put on all PPE required for the work being undertaken (Examples; cut resistant gloves/sleeves, butyl gloves, safety glasses, hard hat/bump cap, fall protection, electrical PPE and arc flash clothing). ALWAYS refer to appropriate Safety Data Sheets (SDS) and OSHA guidelines for proper PPE.**
- **When working with or around hazardous chemicals, ALWAYS refer to the appropriate SDS and OSHA/GHS (Global Harmonized System of Classification and Labelling of Chemicals) guidelines for information on allowable personal exposure levels, proper respiratory protection and handling instructions.**
- **If there is a risk of energized electrical contact, arc, or flash, technicians MUST put on all PPE in accordance with OSHA, NFPA 70E, or other country-specific requirements for arc flash protection, PRIOR to servicing the unit. NEVER PERFORM ANY SWITCHING, DISCONNECTING, OR VOLTAGE TESTING WITHOUT PROPER ELECTRICAL PPE AND ARC FLASH CLOTHING. ENSURE ELECTRICAL METERS AND EQUIPMENT ARE PROPERLY RATED FOR INTENDED VOLTAGE.**

⚠ WARNING**Follow EHS Policies!**

Failure to follow instructions below could result in death or serious injury.

- All Trane personnel must follow the company's Environmental, Health and Safety (EHS) policies when performing work such as hot work, electrical, fall protection, lockout/tagout, refrigerant handling, etc. Where local regulations are more stringent than these policies, those regulations supersede these policies.
- Non-Trane personnel should always follow local regulations.

⚠ WARNING**R-454B Flammable A2L Refrigerant!**

Failure to use proper equipment or components as described below could result in equipment failure, and possibly fire, which could result in death, serious injury, or equipment damage.

The equipment described in this manual uses R-454B refrigerant which is flammable (A2L). Use **ONLY** R-454B rated service equipment and components. For specific handling concerns with R-454B, contact your local representative.

Copyright

This document and the information in it are the property of Trane, and may not be used or reproduced in whole or in part without written permission. Trane reserves the right to revise this publication at any time, and to make changes to its content without obligation to notify any person of such revision or change.

Trademarks

All trademarks referenced in this document are the trademarks of their respective owners.

General Information

Inspection

1. Unpack all components of the kit.
2. Check carefully for shipping damage. If any damage is found, report it immediately, and file a claim against the transportation company.

Parts List

Table 1. Parts list

Item	Description	Qty
1	Damper assembly	1
3	Intermediate block-off panel	1
4	Carrier block-off panel	1
5	Carrier block-off panel	1

Table 1. Parts list (continued)

Item	Description	Qty
6	Block-off panel	1
7	Block-off panel	1
10	Insulated, horizontal block-off panel	1
21	Roll of gasket	1
Installation bag containing:		
14	Installation instructions	1
19	Kit installed label (filed installed kit only)	
20	1-in. x 1-in. x 6-in. gasket	2
	3/4-in. long (#10 screws)	35

Figure 1. Parts (field installed kit)

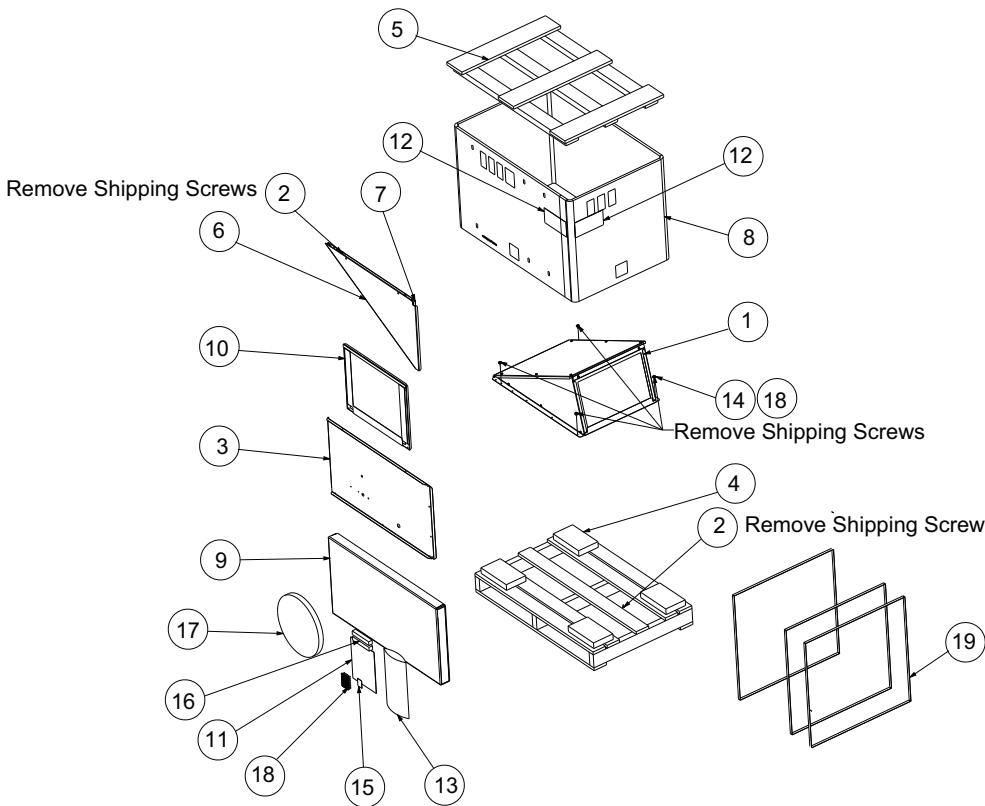
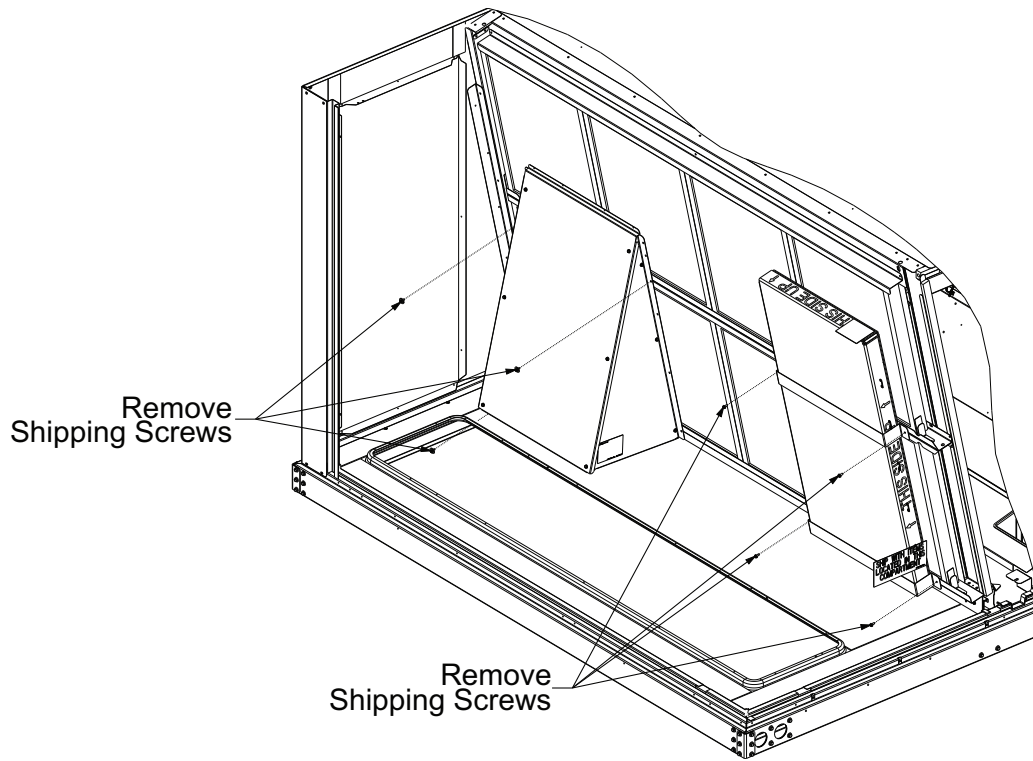

Figure 2. Barometric assembly (factory installed)



Installation

⚠ WARNING

Hazardous Service Procedures!

Failure to follow all precautions in this manual and on the tags, stickers, and labels could result in death or serious injury.

Technicians, in order to protect themselves from potential electrical, mechanical, and chemical hazards, **MUST** follow precautions in this manual and on the tags, stickers, and labels, as well as the following instructions: Unless specified otherwise, disconnect all electrical power including remote disconnect and discharge all energy storing devices such as capacitors before servicing. Follow proper lockout/tagout procedures to ensure the power can not be inadvertently energized. When necessary to work with live electrical components, have a qualified licensed electrician or other individual who has been trained in handling live electrical components perform these tasks.

1. Remove horizontal access panel (1) from the unit.

Figure 3. Remove horizontal access panel

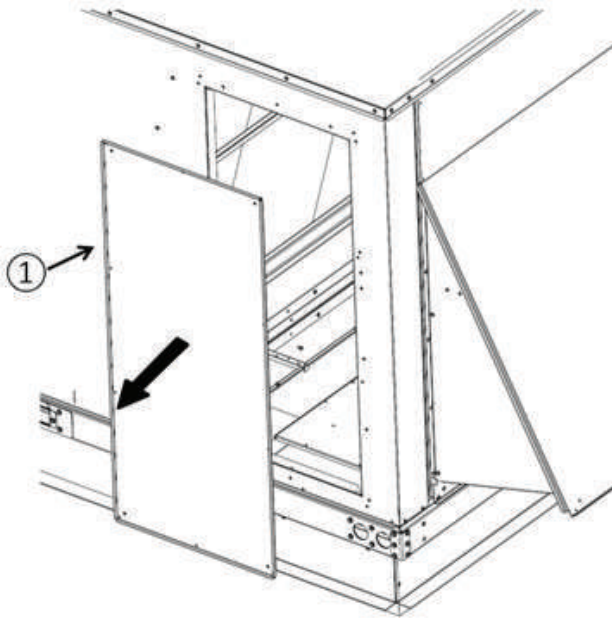

2. Prepare Barometric Relief Kit :
 - a. **Field installed kits:** Remove packaging material and all shipping screws from parts. Remove parts from box.
 - b. **Shipped with unit:** Remove shipping screws from damper assembly and shipping brackets. Discard shipping brackets. Remove parts from box and packaging material.

3. Assemble block-off panel. Attach (1), (2), and (3) using six screws.

Figure 4. Block-off panels

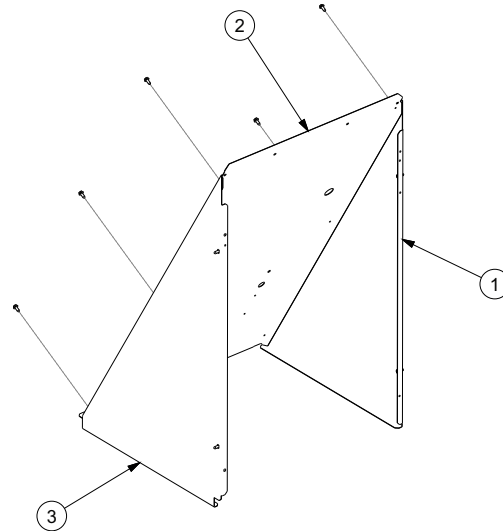

4. Cut one piece of gasket (11) to a length of 4.3 inches. Attach to the bottom of the side block-off panel (1) leaving approximately 3/4-inch gap from end. See Figure 8, p. 7.

Figure 5. Attach gasket to side block-off panel

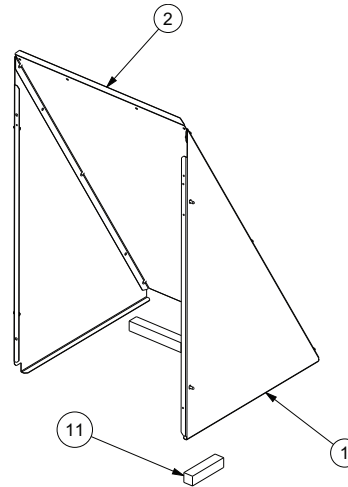

- a. **Standard and Low Leak Economizer:** If comparative enthalpy is installed, attach the return air humidity (RAH) and return air temperature (RAT) sensors to intermediate block-off panel (2) and insert bushing into hole provided on block-off panel. Connect RAH wire harness onto RAH sensor and route wires through bushing.

Note: See the Comparative Enthalpy Kit Precedent™ Packaged Rooftop Units 3 to 25 Tons Installation Instructions (ACC-SVN235*-EN) for further details.

Figure 6. Attach RAH and RAT sensors to block-off panel

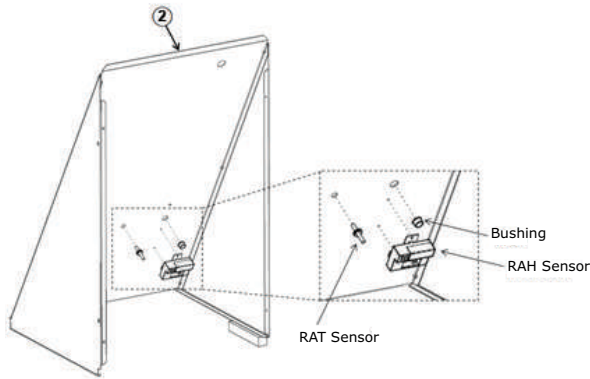

5. Attach one piece of gasket (11) to the base approximately 5 inches long:
 - a. **Standard Economizer:** Align gasket with the return air damper (RAD) bracket.

Figure 7. Attach gasket to base (standard economizer)

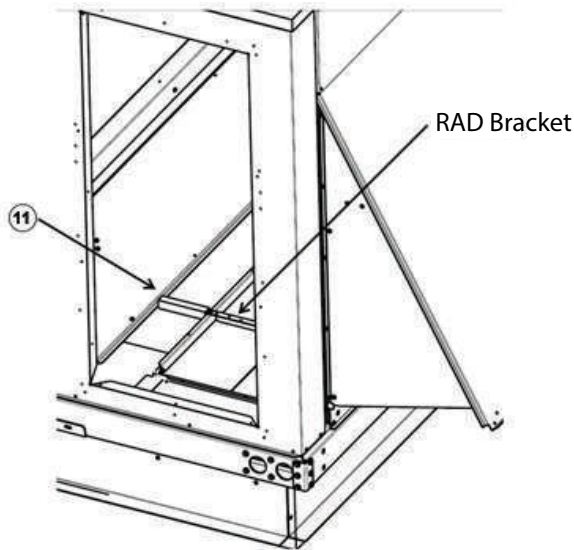

- b. **Low Leak Economizers:** Align gasket with the return air damper flange as shown in [Figure 8, p. 7](#).

Figure 8. Attach gasket to base (low leak economizer)

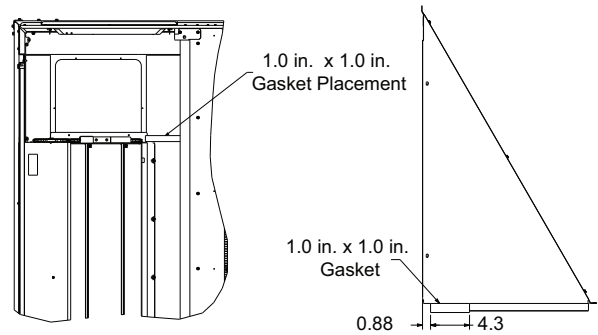

6. Secure barometric block-off:
 - a. Secure barometric block-off assembly to side flanges of return opening using four screws.

Figure 9. Secure barometric block-off to side flanges (standard economizer)

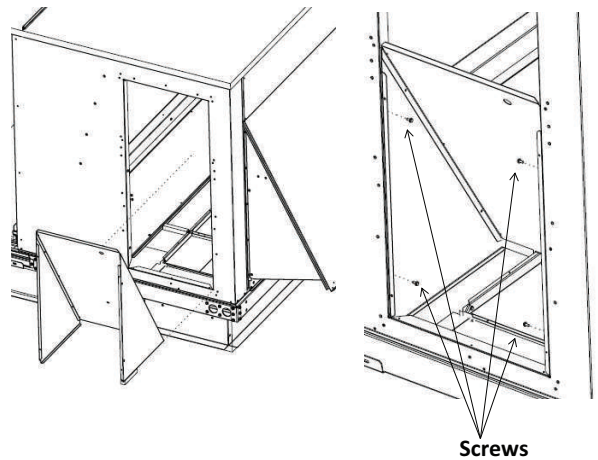
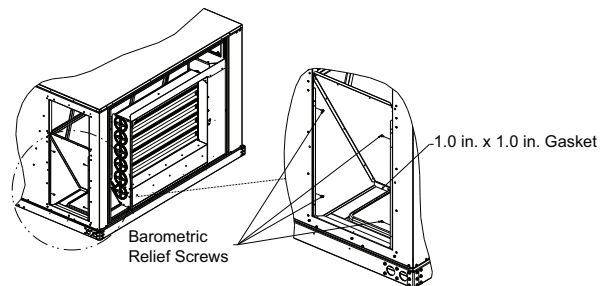
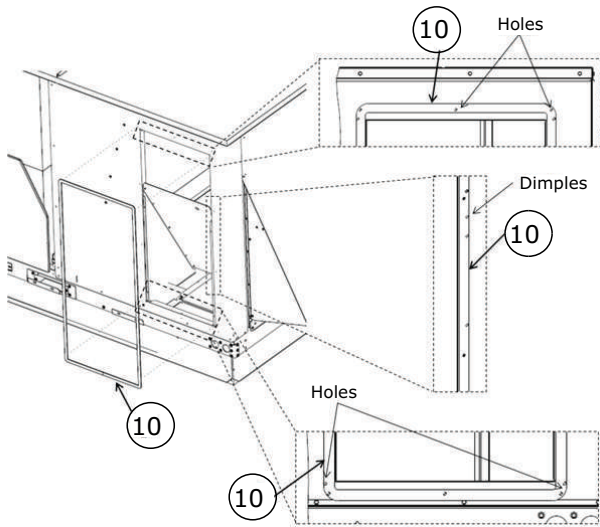

Figure 10. Secure barometric block-off to side flanges (low leak economizer)



7. Attach gasket to unit back panel. Start gasket below the return horizontal duct opening, centered on the opening and aligned with the flange at the base rail. Route gasket to cover holes and dimples along sides and top of the duct opening. Gasket should be one continuous piece overlapping 1-inch at bottom center.

Figure 11. Attach gasket to unit



8. Remove shipping screw from damper assembly (2).

Figure 12. Remove shipping screw from damper assembly

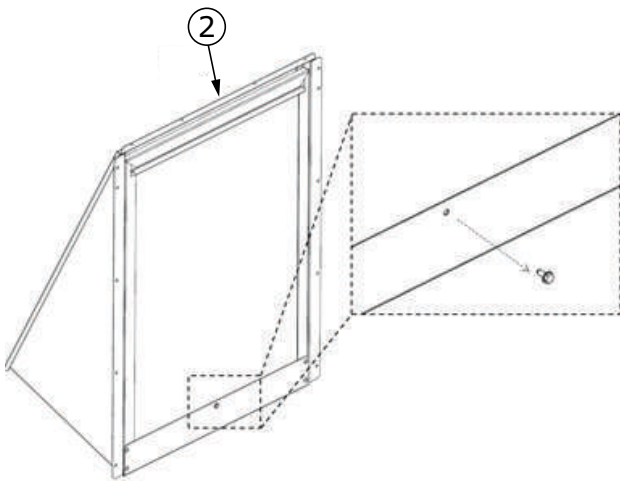

9. Attach damper assembly (2) to unit using ten screws.

Figure 13. Attach damper assembly to unit

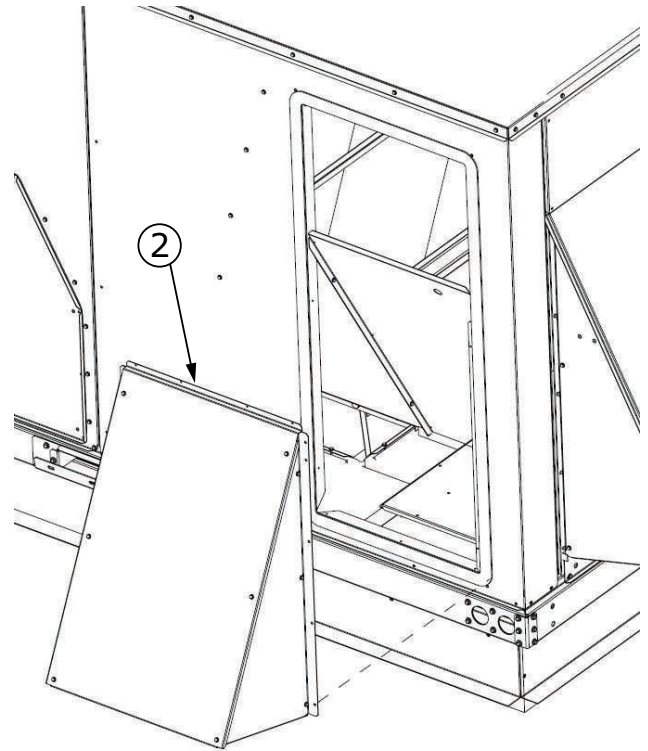

10. Using 10 screws, attach horizontal block-off panel (8) to the unit rear panel and damper assembly (2).

Figure 14. Attach horizontal block-off panel

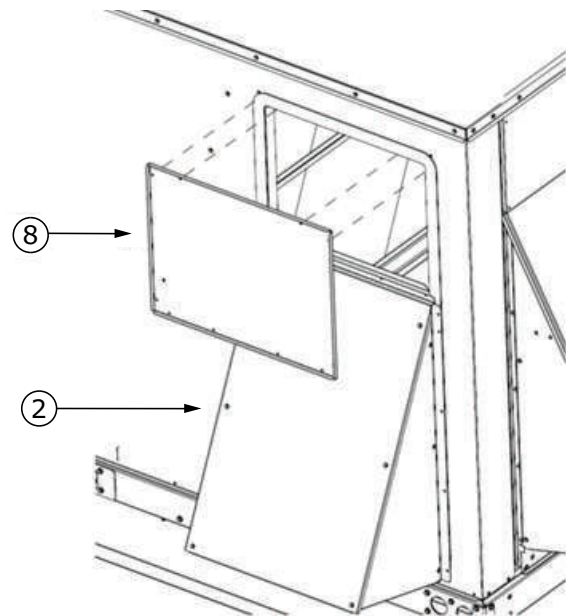

Trane and American Standard create comfortable, energy efficient indoor environments for commercial and residential applications. For more information, please visit trane.com or americanstandardair.com.

Trane and American Standard have a policy of continuous product and product data improvement and reserve the right to change design and specifications without notice. We are committed to using environmentally conscious print practices.

ACC-SVN286A-EN 15 Sep 2024
Supersedes (New)

©2024