

# Installation Instructions

## LonTalk® Communications Interface

Precedent™ Packaged Rooftop Units  
3 to 25 Tons



**Model Number:**  
FIALTCI001\*

**Used With:**  
3 to 25 Ton Precedent with Symbio™ controls

### **⚠ SAFETY WARNING**

Only qualified personnel should install and service the equipment. The installation, starting up, and servicing of heating, ventilating, and air-conditioning equipment can be hazardous and requires specific knowledge and training. Improperly installed, adjusted or altered equipment by an unqualified person could result in death or serious injury. When working on the equipment, observe all precautions in the literature and on the tags, stickers, and labels that are attached to the equipment.



# Introduction

## Warnings, Cautions, and Notices

Safety advisories appear throughout this manual as required. Your personal safety and the proper operation of this machine depend upon the strict observance of these precautions.

---

The three types of advisories are defined as follows:

 <b>WARNING</b>	Indicates a potentially hazardous situation which, if not avoided, could result in death or serious injury.
 <b>CAUTION</b>	Indicates a potentially hazardous situation which, if not avoided, could result in minor or moderate injury. It could also be used to alert against unsafe practices.
<b>NOTICE</b>	Indicates a situation that could result in equipment or property-damage only accidents.

---

## Important Environmental Concerns

Scientific research has shown that certain man-made chemicals can affect the earth's naturally occurring stratospheric ozone layer when released to the atmosphere. In particular, several of the identified chemicals that may affect the ozone layer are refrigerants that contain Chlorine, Fluorine and Carbon (CFCs) and those containing Hydrogen, Chlorine, Fluorine and Carbon (HCFCs). Not all refrigerants containing these compounds have the same potential impact to the environment. Trane advocates the responsible handling of all refrigerants.

## Important Responsible Refrigerant Practices

Trane believes that responsible refrigerant practices are important to the environment, our customers, and the air conditioning industry. All technicians who handle refrigerants must be certified according to local rules. For the USA, the Federal Clean Air Act (Section 608) sets forth the requirements for handling, reclaiming, recovering and recycling of certain refrigerants and the equipment that is used in these service procedures. In addition, some states or municipalities may have additional requirements that must also be adhered to for responsible management of refrigerants. Know the applicable laws and follow them.

### **WARNING**

#### **Proper Field Wiring and Grounding Required!**

**Failure to follow code could result in death or serious injury. All field wiring MUST be performed by qualified personnel. Improperly installed and grounded field wiring poses FIRE and ELECTROCUTION hazards. To avoid these hazards, you MUST follow requirements for field wiring installation and grounding as described in NEC and your local/state/national electrical codes.**

**⚠ WARNING**

**Personal Protective Equipment (PPE) Required!**

Failure to wear proper PPE for the job being undertaken could result in death or serious injury. Technicians, in order to protect themselves from potential electrical, mechanical, and chemical hazards, **MUST** follow precautions in this manual and on the tags, stickers, and labels, as well as the instructions below:

- Before installing/servicing this unit, technicians **MUST** put on all PPE required for the work being undertaken (Examples; cut resistant gloves/sleeves, butyl gloves, safety glasses, hard hat/bump cap, fall protection, electrical PPE and arc flash clothing). **ALWAYS** refer to appropriate Safety Data Sheets (SDS) and OSHA guidelines for proper PPE.
- When working with or around hazardous chemicals, **ALWAYS** refer to the appropriate SDS and OSHA/GHS (Global Harmonized System of Classification and Labeling of Chemicals) guidelines for information on allowable personal exposure levels, proper respiratory protection and handling instructions.
- If there is a risk of energized electrical contact, arc, or flash, technicians **MUST** put on all PPE in accordance with OSHA, NFPA 70E, or other country-specific requirements for arc flash protection, **PRIOR** to servicing the unit. **NEVER PERFORM ANY SWITCHING, DISCONNECTING, OR VOLTAGE TESTING WITHOUT PROPER ELECTRICAL PPE AND ARC FLASH CLOTHING. ENSURE ELECTRICAL METERS AND EQUIPMENT ARE PROPERLY RATED FOR INTENDED VOLTAGE.**

**⚠ WARNING**

**Follow EHS Policies!**

Failure to follow instructions below could result in death or serious injury.

- All Trane personnel must follow the company’s Environmental, Health and Safety (EHS) policies when performing work such as hot work, electrical, fall protection, lockout/tagout, refrigerant handling, etc. Where local regulations are more stringent than these policies, those regulations supersede these policies.
- Non-Trane personnel should always follow local regulations.

**⚠ WARNING**

**R-454B Flammable A2L Refrigerant!**

Failure to use proper equipment or components as described below could result in equipment failure, and possibly fire, which could result in death, serious injury, or equipment damage. The equipment described in this manual uses R-454B refrigerant which is flammable (A2L). Use **ONLY** R- 454B rated service equipment and components. For specific handling concerns with R-454B, contact your local representative.

## Copyright

This document and the information in it are the property of Trane, and may not be used or reproduced in whole or in part without written permission. Trane reserves the right to revise this publication at any time, and to make changes to its content without obligation to notify any person of such revision or change.

## Trademarks

All trademarks referenced in this document are the trademarks of their respective owners.

# General Information

The IzoT™ U60 FT Network Interface Module is a USB to TP/FT-10 network interface module in a compact boardlevel form factor. The IzoT U60 FT Network Interface Module is a board-level module that can be easily integrated with the Symbio™ control system for LonTalk communication.

On-board Tx and Rx LEDs provide an indication of FT packet transmission and reception. The Tx and Rx signals are provided on the U60 connector so that the host controller can provide transmit and receive indicators.

An on-board Service LED provides an indication of the network status of the U60 module. The Service signal is provided on the U60 connector so that the host controller can provide a network Service indicator.

Three pin header connectors are provided by the FT network. The USB, the power input, transmit/receive signals, and the service signal are described in this document. For LonTalk® system integration information, refer to *LonTalk Integration to Odyssey™ Units with Symbio™ 700 Controls Integration Guide (ACC-SVP002\*-EN)*.

## Inspection

1. Unpack all components of the kit.
2. Check carefully for shipping damage. If any damage is found, report it immediately, and file a claim against the transportation company.

## Parts List

Figure 1. Kit contents

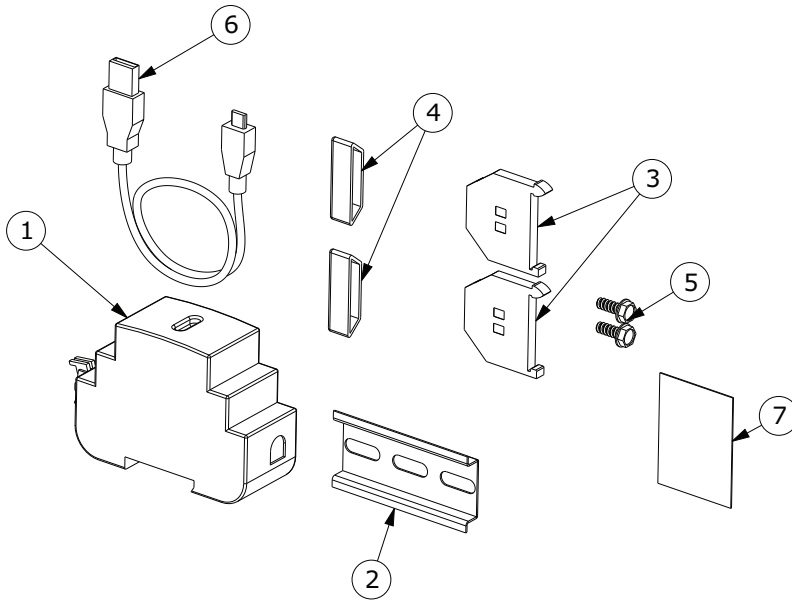

Table 1. Kit parts list

Item	Description	Qty
1	ECHELON IzoT™ U60 FT Network Interface Module	1
2	Din rail	2
3	End stops	2
4	End caps	2
5	Screws	2
6	USB cable	2
7	Information label	1

# Installation

**Important:** If Precedent, digit 21= 0 no communication options are enabled. The Echelon Communication Module will not be supported because Symbio™ 700 is not licensed for this option. Symbio 700 must be replaced with a communication, Advanced Controller, licensed Symbio 700 through service parts.

Figure 2. Precedent™ - LonTalk module location (B, C and D Cabinets)

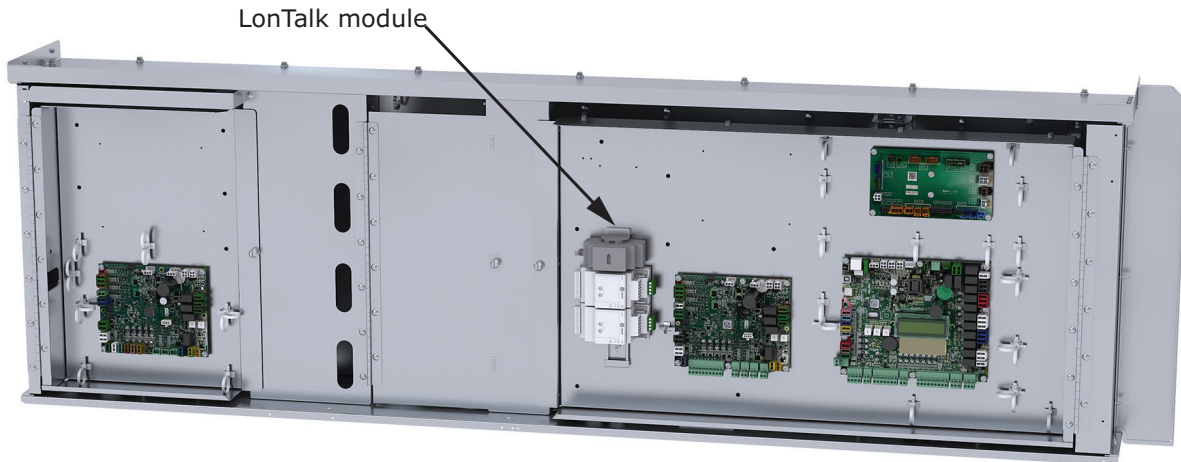
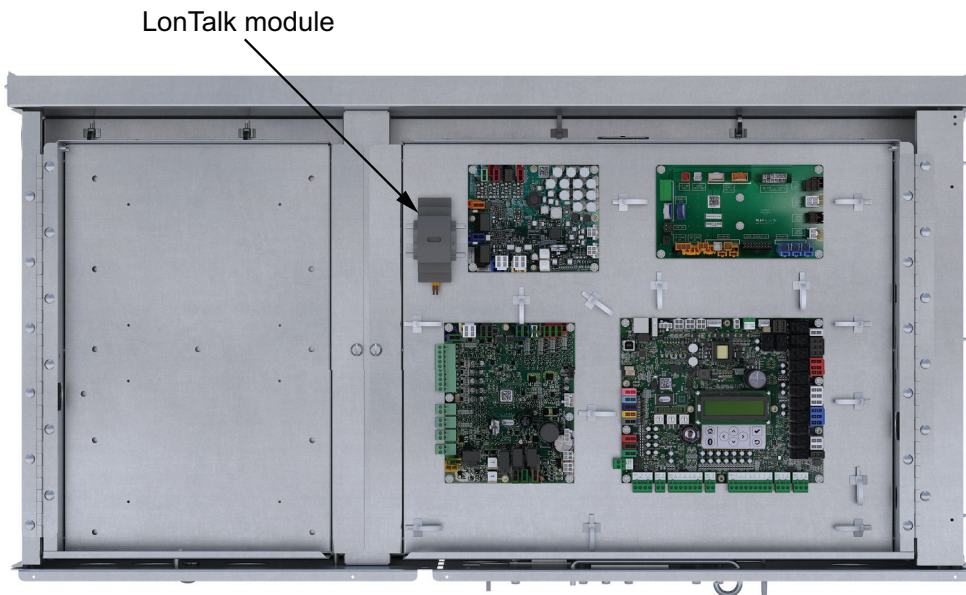

Figure 3. Precedent - LonTalk module location A cabinet



## **⚠ WARNING**

### **Hazardous Voltage w/Capacitors!**

Failure to disconnect power and discharge capacitors before servicing could result in death or serious injury. Disconnect all electric power, including remote disconnects and discharge all motor start/run capacitors before servicing. Follow proper lockout/ tagout procedures to ensure the power cannot be inadvertently energized. Verify with a CAT III or IV voltmeter rated per NFPA 70E that all capacitors have discharged.

## Installation

---

1. Confirm power to the unit has been disconnected and locked out.
2. Remove the unit top access panel and low voltage access panel on the control box.
3. Refer to [Figure 2, p. 5](#) or [Figure 3, p. 5](#) for LonTalk® mounting location. If B/C/D cabinet unit was factory equipped with expansion modules, the din rail will already be installed and can be discarded from kit. A cabinet products will use the shorter of the two supplied din rails in the kit. B, C, D Precedent units will use the longer of the two din rails if required.
4. Mount din rail to right side low voltage door using two supplied #10 screws. Refer to [Figure 2, p. 5](#) for Precedent B, C and D cabinet units. Refer to [Figure 3, p. 5](#) for Precedent A cabinet units.
5. Install LonTalk module to din rail. Locate module to top of the din rail for Precedent B, C, D and Voyager 3 units but leave enough space to secure end stop. Precedent A cabinet units center LonTalk module on din rail, but leave enough space to secure the end stops. Install an end stop on either side of module and tighten securely.
6. Using supplied harness connect single row 4 pin terminal to LonTalk module and the 4 pin dual row connector to USB port on Symbio™ 700 controller. Refer to unit level schematics sheet 3 for full circuitry. After installation is complete, the Symbio 700 UC configuration will need to be updated to enable this installed feature using the Symbio Service and Installation Mobile App or Symbio 700 User Interface.
7. Verify end stops are placed firmly against either side of the module.
8. Install the low voltage access panel and unit access panel that was removed earlier.
9. Apply the information label next to the unit nameplate.
10. Connect all power to the unit.

## Visual Indicators

Three LEDs are located on the primary side of the PCB, centered between the two mounting holes. The SVC LED blinks yellow for service indication. The RX LED flashes green when data is received on the FT network. The TX LED flashes green when data is transmitted on the FT network.



Trane and American Standard create comfortable, energy efficient indoor environments for commercial and residential applications. For more information, please visit [trane.com](http://trane.com) or [americanstandardair.com](http://americanstandardair.com).

Trane and American Standard have a policy of continuous product and product data improvement and reserve the right to change design and specifications without notice. We are committed to using environmentally conscious print practices.