

Installation Instructions

0 to 100% Standard Economizer – Downflow

Foundation™ Cooling and Gas/ Electric
7.5 to 12.5 Tons

Model Number: BAYECON310*

Used With: EBC 090-150, GBC 090-150

▲ SAFETY WARNING

Only qualified personnel should install and service the equipment. The installation, starting up, and servicing of heating, ventilating, and air-conditioning equipment can be hazardous and requires specific knowledge and training. Improperly installed, adjusted or altered equipment by an unqualified person could result in death or serious injury. When working on the equipment, observe all precautions in the literature and on the tags, stickers, and labels that are attached to the equipment.

June 2023

ACC-SVN275A-EN

Introduction

Read this manual thoroughly before operating or servicing this unit.

Warnings, Cautions, and Notices

Safety advisories appear throughout this manual as required. Your personal safety and the proper operation of this machine depend upon the strict observance of these precautions.

The three types of advisories are defined as follows:



Indicates a potentially hazardous situation which, if not avoided, could result in death or serious injury.



Indicates a potentially hazardous situation which, if not avoided, could result in minor or moderate injury. It could also be used to alert against unsafe practices.

NOTICE

Indicates a situation that could result in equipment or property-damage only accidents.

Important Environmental Concerns

Scientific research has shown that certain man-made chemicals can affect the earth's naturally occurring stratospheric ozone layer when released to the atmosphere. In particular, several of the identified chemicals that may affect the ozone layer are refrigerants that contain Chlorine, Fluorine and Carbon (CFCs) and those containing Hydrogen, Chlorine, Fluorine and Carbon (HCFCs). Not all refrigerants containing these compounds have the same potential impact to the environment. Trane advocates the responsible handling of all refrigerants.

Important Responsible Refrigerant Practices

Trane believes that responsible refrigerant practices are important to the environment, our customers, and the air conditioning industry. All technicians who handle refrigerants must be certified according to local rules. For the USA, the Federal Clean Air Act (Section 608) sets forth the requirements for handling, reclaiming, recovering and recycling of certain refrigerants and the equipment that is used in these service procedures. In addition, some states or municipalities may have additional requirements that must also be adhered to for responsible management of refrigerants. Know the applicable laws and follow them.

WARNING

Proper Field Wiring and Grounding Required!

Failure to follow code could result in death or serious injury.

All field wiring MUST be performed by qualified personnel. Improperly installed and grounded field wiring poses FIRE and ELECTROCUTION hazards. To avoid these hazards, you MUST follow requirements for field wiring installation and grounding as described in NEC and your local/state/national electrical codes.

WARNING

Personal Protective Equipment (PPE) Required!

Failure to wear proper PPE for the job being undertaken could result in death or serious injury.

Technicians, in order to protect themselves from potential electrical, mechanical, and chemical hazards, **MUST** follow precautions in this manual and on the tags, stickers, and labels, as well as the instructions below:

- **Before installing/servicing this unit, technicians MUST put on all PPE required for the work being undertaken (Examples; cut resistant gloves/sleeves, butyl gloves, safety glasses, hard hat/bump cap, fall protection, electrical PPE and arc flash clothing). ALWAYS refer to appropriate Safety Data Sheets (SDS) and OSHA guidelines for proper PPE.**
- **When working with or around hazardous chemicals, ALWAYS refer to the appropriate SDS and OSHA/GHS (Global Harmonized System of Classification and Labelling of Chemicals) guidelines for information on allowable personal exposure levels, proper respiratory protection and handling instructions.**
- **If there is a risk of energized electrical contact, arc, or flash, technicians MUST put on all PPE in accordance with OSHA, NFPA 70E, or other country-specific requirements for arc flash protection, PRIOR to servicing the unit. NEVER PERFORM ANY SWITCHING, DISCONNECTING, OR VOLTAGE TESTING WITHOUT PROPER ELECTRICAL PPE AND ARC FLASH CLOTHING. ENSURE ELECTRICAL METERS AND EQUIPMENT ARE PROPERLY RATED FOR INTENDED VOLTAGE.**

⚠ WARNING

Follow EHS Policies!

Failure to follow instructions below could result in death or serious injury.

- All Trane personnel must follow the company's Environmental, Health and Safety (EHS) policies when performing work such as hot work, electrical, fall protection, lockout/tagout, refrigerant handling, etc. Where local regulations are more stringent than these policies, those regulations supersede these policies.
- Non-Trane personnel should always follow local regulations.

Copyright

This document and the information in it are the property of Trane, and may not be used or reproduced in whole or in

part without written permission. Trane reserves the right to revise this publication at any time, and to make changes to its content without obligation to notify any person of such revision or change.

Trademarks

All trademarks referenced in this document are the trademarks of their respective owners.

Revision History

- Added important note for barometric relief provision in Parts List section.
- Updated Installation chapter.
- Updated Economizer Controller section.
- Updated Minimum Position Adjustment section.
- Updated Checkout for W7212 economizer table in Checkout and Troubleshooting chapter.

Table of Contents

Pre-Installation	5	Adjusting Minimum and Maximum	
General Information	5	Positions	10
Unit Inspection	5	Minimum Position Adjustment	11
Exterior Inspection	5	Enthalpy Changeover Setpoint	11
Inspection for Concealed Damage	5	Outdoor Enthalpy Changeover Setpoint	
Parts List	5	(Single Enthalpy)	11
Installation	6	Differential Enthalpy Changeover	
Economizer Controller	8	Setting	12
Operation	8	Exhaust Setpoint	12
Settings and Adjustments	9	Adjustable Exhaust Setpoint	12
Demand Control Ventilation Setpoint	10	Checkout and Troubleshooting	13

Pre-Installation

General Information

The barometric relief hood is sized to provide up to 100% relief. It is designed to meet low leak requirements to prevent infiltration of air when closed.

Unit Inspection

To protect against loss due to damage incurred in transit, perform inspection immediately upon receipt of the unit. Check carefully for shipping damage. If any damage is found, report it immediately, and file a claim against the transportation company.

Exterior Inspection

If the job site inspection reveals damage or material shortages, file a claim with the carrier immediately. Specify the type and extent of the damage on the bill of lading before signing. Notify the appropriate sales representative.

Important: Do not proceed with installation of a damaged unit without sales representative approval.

- Inspect the complete exterior for signs of shipping damages to unit or packing material.
- Verify that the nameplate data matches the sales order and bill of lading.
- Verify that the unit is properly equipped and there are no material shortages.
- Verify the power supply complies with the unit nameplate specifications.

Inspection for Concealed Damage

Inspect the components for concealed damage as soon as possible after delivery and before it is stored.

If concealed damage is discovered:

- Notify the carrier's terminal of the damage immediately by phone and by mail.
- Concealed damage must be reported within 15 days.
- Request an immediate, joint inspection of the damage with the carrier and consignee.
- Stop unpacking the unit.
- Do not remove damaged material from receiving location.
- Take photos of the damage, if possible.
- The owner must provide reasonable evidence that the damage did not occur after delivery.

Parts List

Table 1. Economizer component list

Component	Description
1	Economizer assembly
2	Hood Package
2a	Hood Top
2b	Side A (Left)
2c	Side B (Right)
2d	Center Divider
2e	Aluminum Filter
3	Parts Bag
3a	Screw Bag
3b	Mixed Air Sensor

Figure 1. BAYECON310* package contents

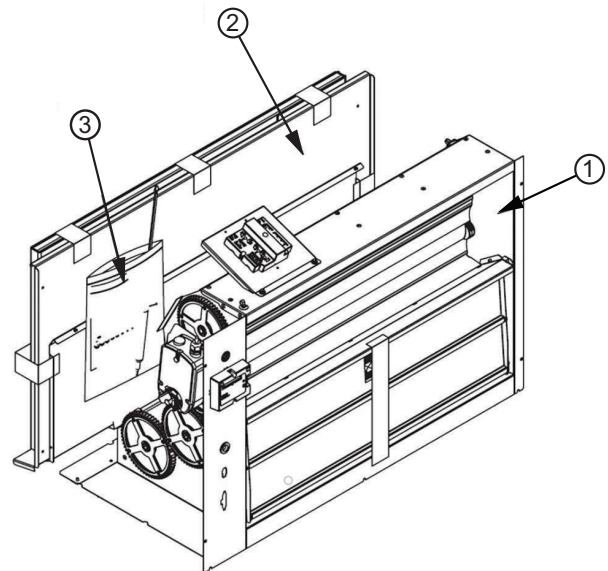

Important: The downflow economizer accessory includes the barometric relief provisions as part of the damper assembly.

Installation

1. Remove hood package from the carton. See [Figure 1, p. 5](#).
2. Assemble the hood. See [Figure 2, p. 6](#).
 - a. Fasten **side A** and **side B** to the **hood top**.
 - b. Fasten the **center divider** in place using the pre-punched holes to guide its placement.
 - c. Place **aluminum filter** at the bottom of the **center divider** and hold in place using the filter clips pre-installed on the **hood top**.

Figure 2. Hood assembly

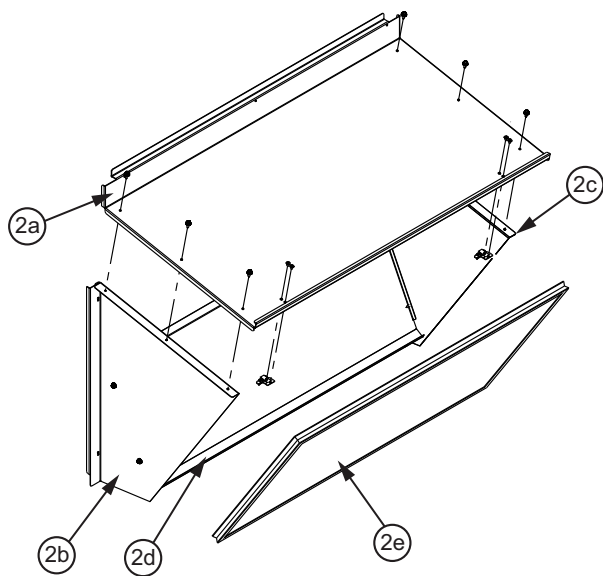

3. Remove filter access panel and outdoor air cover panel. Retain unit screws for attaching economizer and hood. See [Figure 3, p. 6](#).

Figure 3. Unit

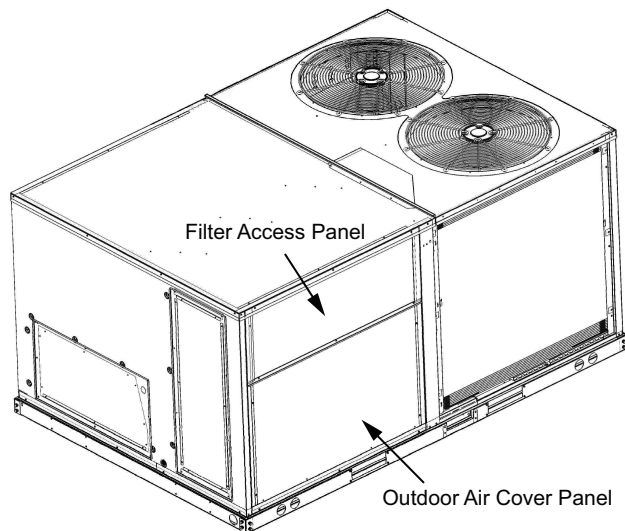

4. Install economizer assembly over the vertical return air opening and attach the economizer to the side post using the existing holes in the unit and pre-punched holes on the economizer. See [Figure 4, p. 6](#).

Figure 4. Economizer assembly installation

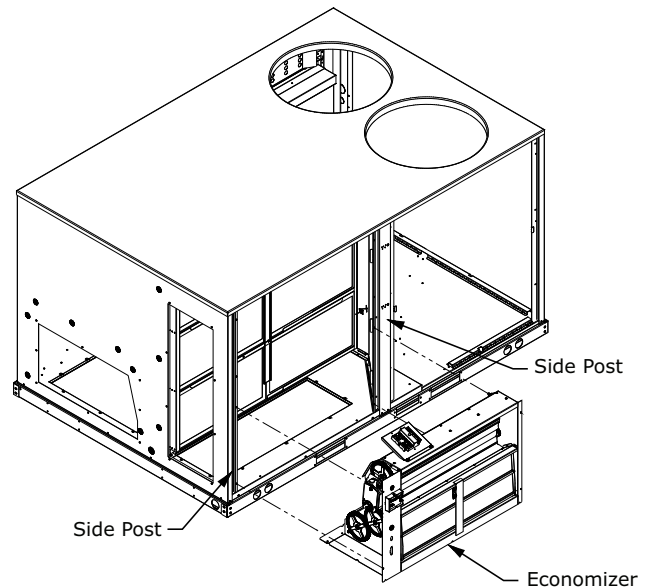

5. Connect the unit harness to the economizer harness. Additionally, connect the green and purple loose wires with plug 1/4-inch quick connects (located next to the unit harness) to the green and purple socket 1/4-inch quick connects from the economizer controller harness. Install economizer hood over the economizer assembly. See [Figure 5, p. 6](#).

Figure 5. Economizer hood installation

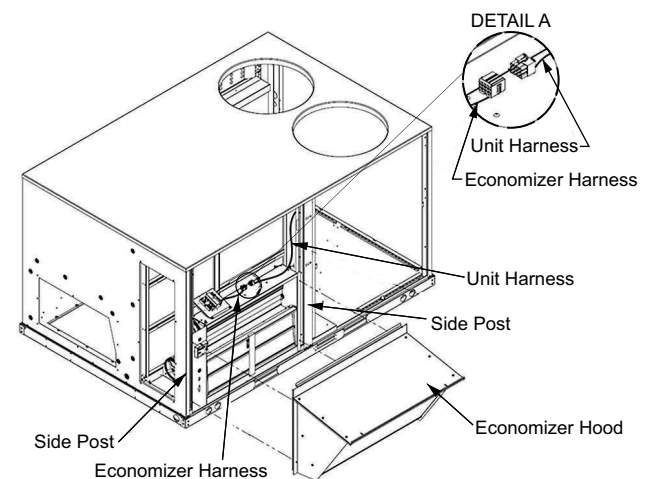

6. Reinstall the filter access panel. See [Figure 6, p. 7](#).

Figure 6. Filter access panel installation

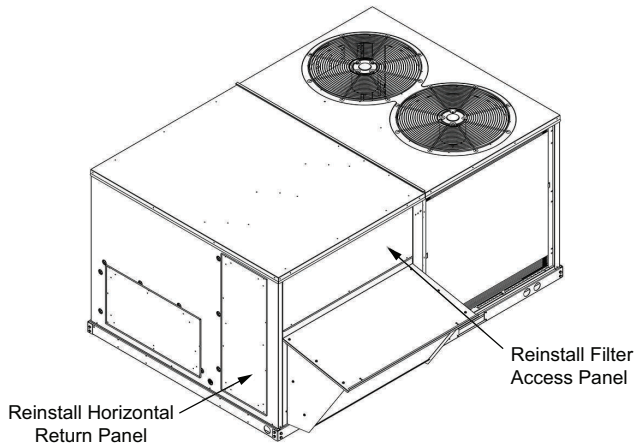

7. Remove the mixed air sensor and two wire purple and green wire harness from the parts bag. Remove the control box panel and supply air blower panel. Connect the two wire harness to the purple and green wires located in the low voltage control box. See .

Figure 7. Low voltage control box

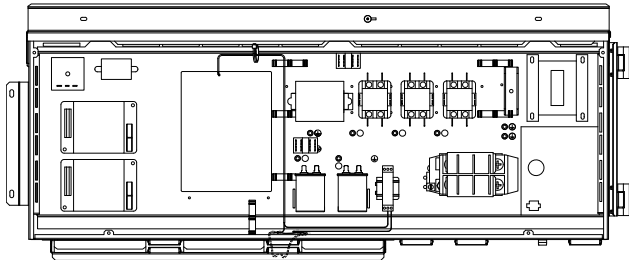

8. Route the two wire purple and green wire harness into the supply air blower section and the mixed air sensor to the supply blower. Confirm the screw does not interfere with the blower operation. Connect the wires to the mixed air sensor. See .

Figure 8. Supply fan blower section

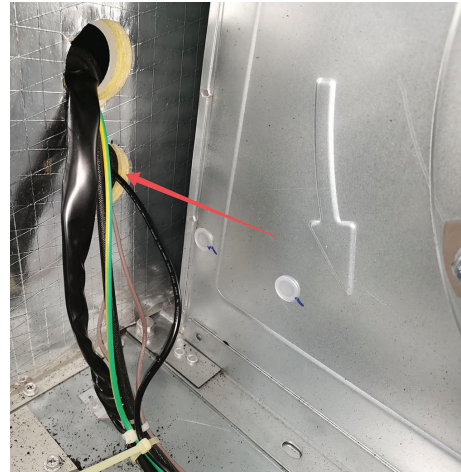

9. Reinstall the supply air blower panel and the control box cover panel.
 10. Read the economizer controller section to determine the set-up for the specific application.

Economizer Controller

Operation

The economizer will use outdoor air for cooling and reduce compressor operation.

Power at the N terminal determines the occupied/unoccupied setting:

W7212:

- 24 Vac (occupied)
- No power (unoccupied)

Note: When module is operating in occupied mode, the minimum position is defined by the potentiometers.

- When the module is operating in unoccupied mode, and there is no call for cooling, the damper drives are

fully closed. The system uses a C7660 dry bulb temperature sensor. The C7660 responds to dry bulb temperature.

Important: Do not use the C7660 in differential dry bulb applications.

- The logic module functions as a true first stage of cooling providing maximum energy economy during the cooling cycle. It automatically locks out free cooling during heating; holding the outdoor air damper at the minimum position setting (or if using demand control ventilation and the space CO₂ level is above the setpoint, the damper will be between the MIN POS and DCV MAX position).

Table 2. W7212 DCV I/O logic

Occupied Terminal N has 24 VAC power	Input on AQ-AQ1 terminals ^(a)	Action with 24 VAC power applied to W7212 (TR-TR1)
Yes	1 Vdc	Drives to MIN POS
No	1 Vdc	No movement of motor
Yes	<1 Vdc	Drives to MIN POS or DCV MAX (highest)
No ^(b)	<1 Vdc	Drives to DCV MAX
Yes	DCV setpoint	Drives to up to MIN POS or DCV MAX (highest)
No	DCV setpoint	Drives to DCV MAX

^(a) <1 Vdc = no CO₂ sensor or failed sensor; 1 Vdc = CO₂ sensor working but below CO₂ setpoint and CO₂ sensor working and above setpoint.

^(b) Economizer should be powered by fan, if fan is off economizer will spring return damper closed, if fan is on and no occupancy damper will drive to DCV MAX position.

The logic module can operate as either a basic free cooling controller, or it can incorporate additional functions. [Table 3, p. 9](#) details the input/output (I/O) logic of the module.

Table 3. W7212 economizer I/O logic

Inputs				Outputs			
Demand Control Ventilation (DCV)	Dry Bulb Setpoint ^(a)	Y1	Y2	Compressor		N Terminal ^(b)	
	Outdoor			Stage 1	Stage 2	Occupied ^(b)	Unoccupied ^(b)
						Damper	
Below set (DCV LED Off) See Table 2, p. 8 for outdoor damper action if input on AQ-AQ1 terminals is 1Vdc or < 1Vdc. This is the fault for CO ₂ sensor failure. If no sensor or Vdc input is added to AQ-AQ1 terminals then use the DCV MAX potentiometer to adjust the minimum position.	High (Free Cooling LED Off)	On	On	On	On	Minimum position	Closed
		On	Off	On	Off		
		Off	Off	Off	Off		
	Low (Free Cooling LED On)	On	On	On	Off	Modulating ^(c) (between min. position and full-open)	Modulating ^(c) (between closed and full-open)
		On	Off	Off	Off		
		Off	Off	Off	Off	Minimum position	Closed
Above set (DCV LED On)	High (Free Cooling LED Off)	On	On	On	On	Modulating ^(d) (between min. position and DCV maximum)	Modulating ^{(d), (e)} (between closed and DCV maximum)
		On	Off	On	Off		
		Off	Off	Off	Off		
	Low (Free Cooling LED On)	On	On	On	Off	Modulating ^(f)	Modulating ^(g)
		On	Off	Off	Off		
		Off	Off	Off	Off		

^(a) For single enthalpy control, the module compares outdoor enthalpy to the A,B,C,D,E setpoint.

^(b) Power at N terminal determines occupied/unoccupied setting:

- W7212: 24 Vac (occupied), no power (unoccupied).
- W7213, W7214: No power (occupied), 24 Vac (unoccupied).

^(c) Modulation is based on the mixed air sensor signal.

^(d) Modulation is based on the DCV signal. If the CO₂ sensor input (AQ-AQ1) terminals is < 1Vdc or the sensor has failed, the motor will drive to MIN POS or DCV MAX whichever is highest.

^(e) Modulation is based on the DCV signal, if the CO₂ sensor input (AQ-AQ1) terminals is < 1Vdc or the sensor has failed, the motor will drive DCV MAX in the occupied mode. When power is cut to the economizer (fan is off) then the damper will spring return closed.

^(f) Modulation is based on the greater of DCV and mixed air sensor signals, between minimum position and either maximum position (DCV) or fully open (mixed air signal).

^(g) Modulation is based on the greater of DCV and mixed air sensor signals, between closed and either maximum position (DCV) or fully open (mixed air signal).

Settings and Adjustments

NOTICE

Equipment Damage!

Excessive force can damage potentiometer controls. Use a small screwdriver or the plastic tool provided with the economizer when adjusting all potentiometers located on the unit.

Potentiometers with screwdriver adjustment slots, located on device face, provide adjustments for several parameters (see Fig. 9 for locations on device):

- DCV setpoint
- Minimum damper position
- DCV maximum damper position
- Enthalpy changeover
- Exhaust setpoint

Figure 9. S963B1128 remote potentiometer used with logic module for remote damper control

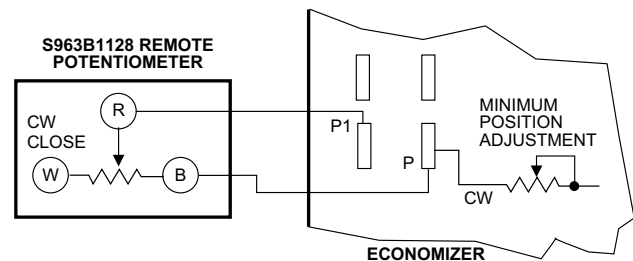
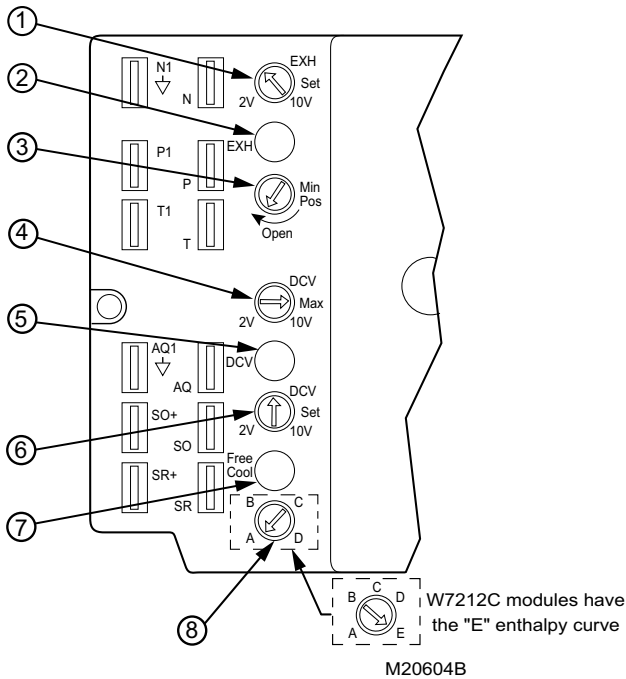

Figure 10. Potentiometer and LED locations



Item	Description
1	Exhaust fan setpoint
2	Led lights when exhaust contact is made
3	Minimum damper position setting
4	Maximum damper demand control ventilation setpoint
5	Led lights when demand control ventilation input is above setpoint
6	Demand control ventilation setpoint
7	Led lights when outdoor air is suitable for free cooling
8	Enthalpy changeover setpoint

Demand Control Ventilation Setpoint

The logic module modulates the outdoor damper to provide ventilation based on the 2 to 10 Vdc DCV input (AQ-AQ1 terminals). With no cooling signal, the DCV overrides the outdoor air damper when ventilation requires additional outdoor air.

EXAMPLE: CO₂ sensor with 2 to 10 Vdc output range 0 to 2000 ppm. Two Vdc is equal to 0 ppm, 10 Vdc is equal to

2000 ppm, threshold is determined to be 1000 ppm. DCV potentiometer to be set at 6 Vdc.

1. Adjust the potentiometer with a small screwdriver by turning the pot to the fully CCW then fully CW positions to determine the end stops.
2. Set the pot for 6 Vdc in the mid position.

Adjusting Minimum and Maximum Positions

The minimum position is defined by the minimum outdoor airflow required in the building during the occupied period. The MIN POS and DCV MAX position potentiometers allow the installer to set the proper ventilation based on occupancy established by ASHRAE standard 62.1. When used with a CO₂ occupancy sensor the minimum position will modulate between the MIN POS pot setting and the DCV MAX pot setting based on the CO₂ input to the AQ-AQ1 terminals from the CO₂ sensor located in the space.

When a CO₂ sensor is **not used** with the unit, the OA dampers will modulate based on the actions in Table 2, p. 8. Setting the DCV maximum position of the damper prevents the introduction of large amounts of hot or cold air into the space by preventing the dampers from opening 100% during a call for additional ventilation. On a call for cooling and the OA is good for economizing, the unit will override the DCV MAX setting and allow the dampers to drive full open.

Important: With the DCV maximum position set below the minimum position, the minimum position overrides the maximum position.

Notes:

- When the mixed air sensor takes control based on an increased requirement for cooling, it overrides the DCV maximum position potentiometer and can drive the damper full-open.
- If the mixed air temperature drops to 45°F, the mixed air sensor overrides the DCV and closes the damper to protect from freezing the hot or chilled water coils. Control returns to normal once the mixed air temperature rises to 48°F. Some models of the W7212 close the damper fully and others close the damper to minimum position. Check the label on the box for position of damper on freeze protection. If the CO₂ sensor should fail, the W7212 defaults to DCV maximum, providing minimum ventilation for the maximum design occupancy.

Minimum Position Adjustment

The following provides basic guidelines for minimum position selection and adjustment.

Important:

- As required by local code to enter the building, adjust the minimum position potentiometer to allow the minimum amount of outdoor air for building effluents.
- This procedure requires use of a quality thermometer capable of reading to 0.5°F [0.25°C].

Note: Make ventilation adjustments with at least a 10°F [6°C] temperature difference between outdoor and return air.

- Equation 1 will be used to calculate the mixed air temperature and set the damper positions for **MIN POS** and **DCV MAX**.
 - Without a DCV sensor connected to AQ-AQ1, use the **MIN POS** pot and this procedure to adjust the damper positions for minimum OA when the space is occupied.
 - When using a DCV sensor, set the **MIN POS** and **DCV MAX** positions using this procedure. DCV MAX will be the same as the MIN POS above (without a DCV sensor) and the MIN POS will lower than the DCV MAX %.
- Disconnect mixed air sensor from terminals T and T1.
- Place a jumper across terminals T and T1.
- Confirm either the factory-installed jumper is in place across terminals P and P1. If a remote damper position is required, wire according to [Figure 9, p. 9](#), and validate the **MIN POS** potentiometer is turned full clockwise.
- Connect 24 Vac across terminals TR and TR1.
- Carefully adjust the potentiometer on the face of the device with a small screwdriver until the mixed air temperature reaches the calculated value.

Note: Confirm that the sensed air is well mixed.

- If all minimum (MIN POS) and maximum position (DCV MAX) adjustments are complete, remove the T-T1 jumper and reconnect the mixed air sensor.

Equation 1: Formula to aid minimum position adjustment.	
$(T_O \times OA) + (T_R \times RA) = T_M$	Where: T _O = Outdoor air temperature OA = Percent of outdoor air T _R = Return air temperature RA = Percent of return air T _M = Resulting mixed air temperature

The following sample calculation uses only Fahrenheit temperature.

EXAMPLE: Assume local codes require 10% outdoor air during occupied conditions, outdoor air is 60°F and return air is 75°F. Under these conditions, what is the temperature of the mixed air?

$$(0.1 \times 60^\circ\text{F}) + (0.9 \times 75^\circ\text{F}) = 6.0^\circ\text{F} + 67.5^\circ\text{F} = 73.5^\circ\text{F}$$

Mixed air will be 73.5°F when OA is 60°F and RA is 75°F with 10 percent outdoor air entering the building.

Note: If setting MIN POS and DCV MAX position, adjust the MIN POS for the building effluent (low occupancy) airflow and adjust the DCV MAX using the minimum airflow for maximum occupancy.

Enthalpy Changeover Setpoint

Outdoor Enthalpy Changeover Setpoint (Single Enthalpy)

- Single enthalpy compares the outdoor air conditions to a set A, B, C, or D (E) curve for humidity and temperature conditions. The installer must set the onboard potentiometer to the desired curve.
- The outdoor enthalpy changeover setpoint returns the outdoor air damper to minimum position. Enthalpy setpoint scale markings located in the device are A, B, C, D and E. See [Figure 10, p. 10](#) for the corresponding control points.
- The factory-installed 620-ohm jumper must be in place across terminals SR and SR+. Temperature and humidity conditions to the left of the selected curve will allow the dampers to open for free cooling, temperature, and humidity conditions to the right of the curve will return the OA damper to minimum position (this is either MIN POS if using a CO₂ sensor or DCV MAX if a CO₂ sensor is **not** used).

Figure 11. Potentiometer and LED locations (W7212 shown)

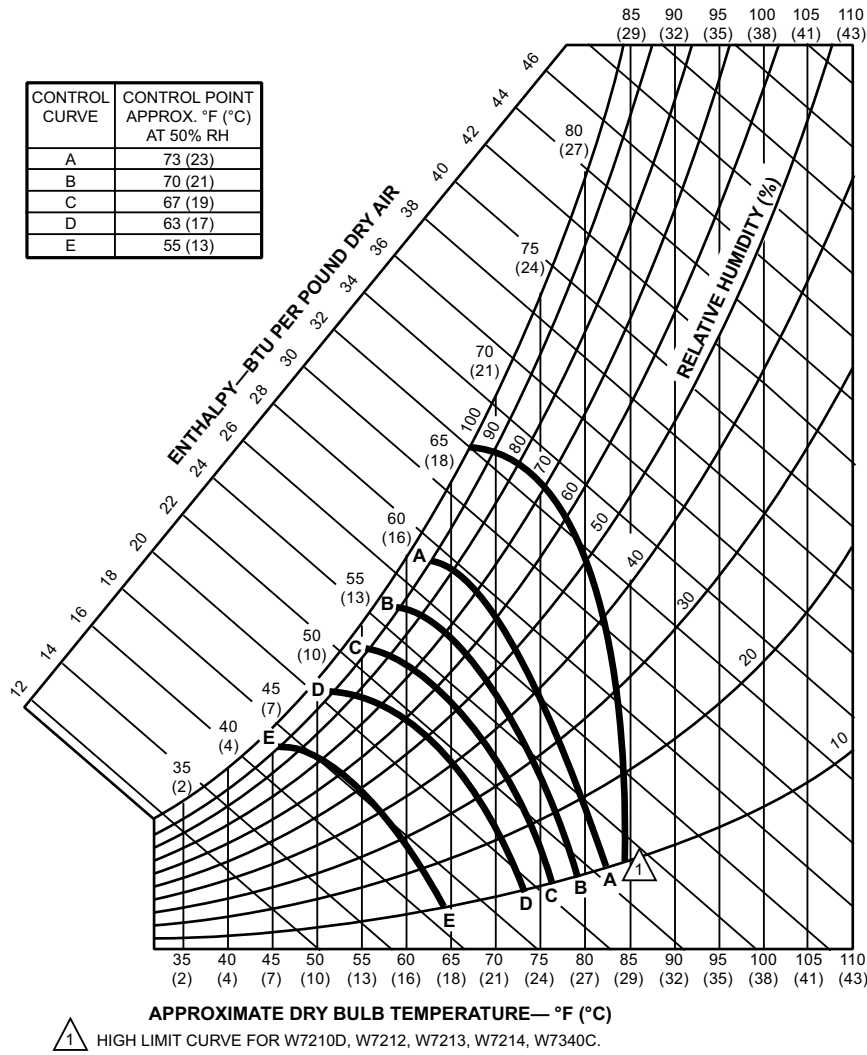

Differential Enthalpy Changeover Setting

Differential enthalpy control uses two C7400 enthalpy sensors connected to one logic module. The logic module compares outdoor air to return air.

Note: Turn the enthalpy setpoint potentiometer fully clockwise to the D (or E setting for W7212C) setting.

The logic module selects the lower enthalpy air (return or outdoor) for cooling. For example, when outdoor air has lower enthalpy than return air, the module calls to open the outdoor air damper to bring in outdoor air for free cooling.

Exhaust Setpoint

The exhaust setpoint determines when the exhaust fan runs based on damper position. When the exhaust fan call is made, the module provides a 60 ±30 second delay before exhaust fan activation. This delay allows the damper to reach the appropriate position to avoid unnecessary fan overload.

Notes:

- EF and EF1 are 24V dry contacts only. An external line voltage contactor is required to operate the exhaust fan.
- When the exhaust fan is deactivated the EF and EF1 contacts open immediately.

Adjustable Exhaust Setpoint

These logic modules have an adjustable exhaust setpoint. This potentiometer allows the installer to adjust the damper position at which the EF and EF1 exhaust fan contacts are made.

Note: The 60 ±30 second delay allows the outdoor damper to reach the exhaust setpoint prior to the EF and EF1 contacts being made.

Checkout and Troubleshooting

Checkout requires a 9V battery, 620 ohm, 1.2K ohm, 5.6K ohm, and 6.8K ohm resistors. Use [Table 4, p. 14](#) and [Figure 12, p. 13](#) for checkout.

NOTICE

Equipment Damage!
 Excessive force can damage potentiometer controls. Use a small screwdriver or the plastic tool provided with the economizer when adjusting all potentiometers located on the unit.

Figure 12. Meter location for checkout

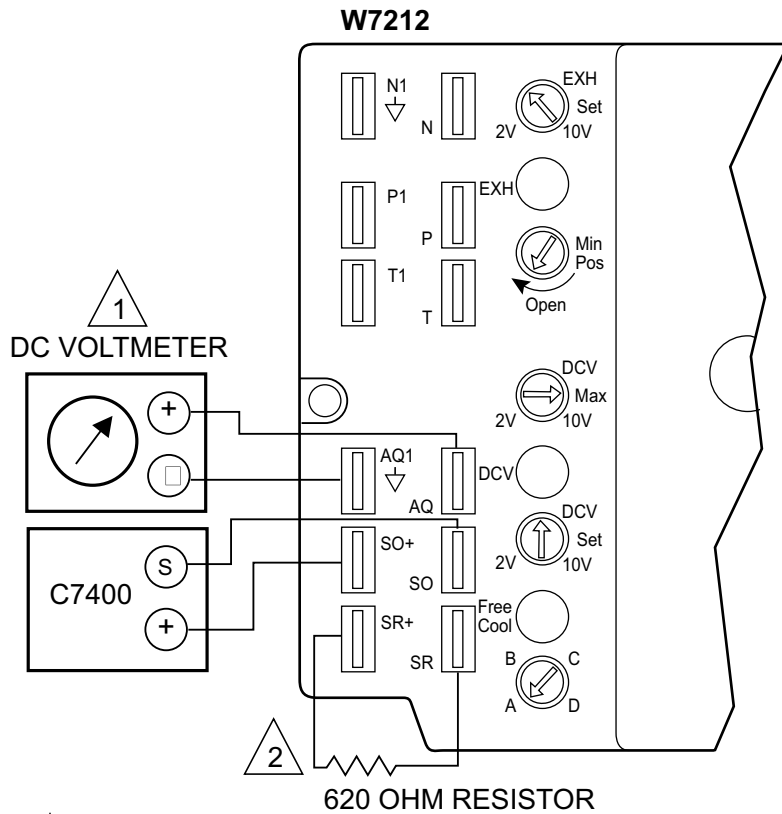

1 INSERT DC VOLTmeter BETWEEN AQ AND AQ1 FOR CHECKOUT AND TROUBLESHOOTING.

2 JUMPER USED FOR SINGLE ENTHALPY CONTROL.

Checkout and Troubleshooting

Table 4. Checkout for W7212 economizer

Step	Checkout Procedure	Proper Response
a.	Checkout Preparation for Economizing only	
	Disconnect power at TR and TR1.	All LED are off. Exhaust fan contacts are open.
	Disconnect devices at P and P1.	
	Jumper P to P1 (defaults to on board MIN POS potentiometer).	
	Place 5.6K ohm resistor across T and T1 (Blue sleeve provides input to economizer that the MAT is between 50-55°F).	
	Jumper TR to 1 (call for cooling from the thermostat).	
	W7212 only: Jumper TR to N (places economizer in occupied mode).	
	If connected, remove C7400 enthalpy sensor from terminals S _O and +.	
	Connect 1.2K ohm, from 4074EJM checkout resistor kit, (purple sleeve) across terminals S _O and + (makes OA enthalpy high).	
	Place 620 ohm resistor (white sleeve) across S _R and + (makes return enthalpy lower than OA).	
	Set MIN POS and DCV MAX potentiometers fully CCW.	
	Turn DCV setpoint potentiometer mid position (this sets the DCV ventilation at approximately 1000 ppm).	
	Turn exhaust potentiometer to mid position (motor will be approximately 50% open when the exhaust fan contacts make).	
	Set enthalpy potentiometer to D.	
	W7214 only: Jumper TR to O.	
Apply power (24 Vac) to terminals TR and TR1.		
b.	Differential Enthalpy	
	Execute step one: Checkout Preparation .	—
	Turn DCV MAX to mid position.	
	Place 620 ohm resistor across S _O and + (white sleeve resistor makes OA enthalpy low).	—
	Place 1.2K ohm resistor across S _R and + (purple sleeve resistor makes RA enthalpy high).	Free cool LED turns on. Motor drives to approximately 45 degrees (half) open.
	Remove 620 ohm resistor from S _O and +.	Free cool LED turns off: Motor drives closed
c.	Single Enthalpy	
	Execute step one: Checkout Preparation .	—
	Turn DCV MAX to mid position.	
	Set enthalpy potentiometer to A (fully CCW).	Free cool LED turns on. Motor drives to approximately 45 degrees (half) open.
	Set enthalpy potentiometer to D or E for W7212C (fully CW).	Free cool LED turns off: Motor drives closed

Table 4. Checkout for W7212 economizer (continued)

Step	Checkout Procedure	Proper Response
d.	DCV and Exhaust	
	Execute step one: Checkout Preparation.	—
	LED for both DCV and exhaust should be off.	
	Turn DCV MAX to mid position.	Motor drives to mid position, 45 degrees open.
	Turn MIN POS fully CW.	Motor drives fully open.
	Turn MIN POS and DCV MAX to fully CCW.	Motor drives closed.
	Turn DCV MAX to mid position. Connect 9V battery positive to AQ and negative to AQ1.	LED for both DCV and exhaust turn on. Actuator drives to 45 degrees open.
	Remove jumper from N terminal (economizer goes into not occupied mode).	Motor remains at 45 degrees open.
	Adjust DCV MAX towards CW.	Motor will move to position set by DCV MAX pot.
	Adjust DCV MAX to fully CCW.	Motor will drive closed.
	Reconnect jumper to N terminal.	
	Adjust DCV MAX and MIN POS pots.	Motor will drive to the most open position of the pots.
	Adjust DCV MAX and MIN POS pots to fully CCW.	
	Remove power from N terminal adjust MIN POS towards CW	Motor should not move.
	Adjust DCV MAX towards CW.	Motor will move to position set by DCV MAX pot.
e.	Minimum and Maximum Position	
	Execute step one: Checkout Preparation.	—
	Connect 9V battery positive to AQ and negative to AQ1. Adjust DCV MAX potentiometer to mid position.	DCV LED turns on. Actuator drives to 45 degrees open.
	Turn DCV maximum position potentiometer to fully CCW.	Actuator drives fully closed.
	Turn minimum position potentiometer to midpoint.	Actuator drives to 45 degrees open.
	Turn minimum position potentiometer fully CW.	Actuator drives fully open.
	Turn MIN POS to fully CCW.	Actuator drives fully closed.
	W7212: Remove jumper from TR and N.	Actuator drives fully closed.
	W7214: Jumper TR to O.	
f.	Mixed Air Input	
	Execute step one: Checkout Preparation.	—
	Turn DCV MAX to mid position and set enthalpy potentiometer to A.	Free cool LED turns on. Actuator drives to 45 degrees open.
	Remove 5.6K ohm resistor (green sleeve) and place jumper from T and T1.	Actuator drives to 45 degrees open.
	Remove jumper from T and T1 and leave open.	Actuator drives fully closed.
g.	Heat Pump Input - w7213, w7214 only	
	Execute step one: Checkout Preparation.	—
	Turn DCV MAX to mid position and set enthalpy potentiometer to A.	Free cool LED turns on. Actuator drives to 45 degrees open.
	W7213: Jumper TR to B. W7214: Remove jumper from TR and O.	Free cool LED turns off. Actuator drives fully closed.

Trane and American Standard create comfortable, energy efficient indoor environments for commercial and residential applications. For more information, please visit trane.com or americanstandardair.com.

Trane and American Standard have a policy of continuous product and product data improvement and reserve the right to change design and specifications without notice. We are committed to using environmentally conscious print practices.

ACC-SVN275A-EN 20 Jun 2023
Supersedes RT-SVN042A-EN (July 2021)

©2023