

Installation Instructions

Power Exhaust Kit

Foundation™ Packaged Rooftop Units

3 to 5 Tons

Model Numbers: Used With:

BAYPWRX320* G/EB*036-060A3, G/ED*036-060A3

BAYPWRX321* G/EB*036-060A4, G/ED*036-060A4

BAYPWRX322* G/EB*036-060AW, G/ED*036-060AW

SAFETY WARNING

Only qualified personnel should install and service the equipment. The installation, starting up, and servicing of heating, ventilating, and air-conditioning equipment can be hazardous and requires specific knowledge and training. Improperly installed, adjusted or altered equipment by an unqualified person could result in death or serious injury. When working on the equipment, observe all precautions in the literature and on the tags, stickers, and labels that are attached to the equipment.

Introduction

Read this manual thoroughly before operating or servicing this unit.

Warnings, Cautions, and Notices

Safety advisories appear throughout this manual as required. Your personal safety and the proper operation of this machine depend upon the strict observance of these precautions.

The three types of advisories are defined as follows:

⚠ WARNING Indicates a potentially hazardous situation which, if not avoided, could result in death or serious injury.

⚠ CAUTION Indicates a potentially hazardous situation which, if not avoided, could result in minor or moderate injury. It could also be used to alert against unsafe practices.

NOTICE Indicates a situation that could result in equipment or property-damage only accidents.

Important Environmental Concerns

Scientific research has shown that certain man-made chemicals can affect the earth's naturally occurring stratospheric ozone layer when released to the atmosphere. In particular, several of the identified chemicals that may affect the ozone layer are refrigerants that contain Chlorine, Fluorine and Carbon (CFCs) and those containing Hydrogen, Chlorine, Fluorine and Carbon (HCFCs). Not all refrigerants containing these compounds have the same potential impact to the environment. Trane advocates the responsible handling of all refrigerants.

Important Responsible Refrigerant Practices

Trane believes that responsible refrigerant practices are important to the environment, our customers, and the air conditioning industry. All technicians who handle refrigerants must be certified according to local rules. For the USA, the Federal Clean Air Act (Section 608) sets forth the requirements for handling, reclaiming, recovering and recycling of certain refrigerants and the equipment that is used in these service procedures. In addition, some states or municipalities may have additional requirements that must also be adhered to for responsible management of refrigerants. Know the applicable laws and follow them.

⚠ WARNING

Proper Field Wiring and Grounding Required!

Failure to follow code could result in death or serious injury. All field wiring **MUST** be performed by qualified personnel. Improperly installed and grounded field wiring poses **FIRE** and **ELECTROCUTION** hazards. To avoid these hazards, you **MUST** follow requirements for field wiring installation and grounding as described in **NEC** and your local/state/national electrical codes.

⚠ WARNING

Personal Protective Equipment (PPE) Required!

Failure to wear proper PPE for the job being undertaken could result in death or serious injury. Technicians, in order to protect themselves from potential electrical, mechanical, and chemical hazards, **MUST** follow precautions in this manual and on the tags, stickers, and labels, as well as the instructions below:

- Before installing/servicing this unit, technicians **MUST** put on all PPE required for the work being undertaken (Examples; cut resistant gloves/sleeves, butyl gloves, safety glasses, hard hat/bump cap, fall protection, electrical PPE and arc flash clothing). **ALWAYS** refer to appropriate Safety Data Sheets (SDS) and OSHA guidelines for proper PPE.
- When working with or around hazardous chemicals, **ALWAYS** refer to the appropriate SDS and OSHA/GHS (Global Harmonized System of Classification and Labeling of Chemicals) guidelines for information on allowable personal exposure levels, proper respiratory protection and handling instructions.
- If there is a risk of energized electrical contact, arc, or flash, technicians **MUST** put on all PPE in accordance with OSHA, NFPA 70E, or other country-specific requirements for arc flash protection, **PRIOR** to servicing the unit. **NEVER PERFORM ANY SWITCHING, DISCONNECTING, OR VOLTAGE TESTING WITHOUT PROPER ELECTRICAL PPE AND ARC FLASH CLOTHING. ENSURE ELECTRICAL METERS AND EQUIPMENT ARE PROPERLY RATED FOR INTENDED VOLTAGE.**

⚠ WARNING

Follow EHS Policies!

Failure to follow instructions below could result in death or serious injury.

- All Trane personnel must follow the company's Environmental, Health and Safety (EHS) policies when performing work such as hot work, electrical, fall protection, lockout/tagout, refrigerant handling, etc. Where local regulations are more stringent than these policies, those regulations supersede these policies.
- Non-Trane personnel should always follow local regulations.

⚠ WARNING

R-454B Flammable A2L Refrigerant!

Failure to use proper equipment or components as described below could result in equipment failure, and possibly fire, which could result in death, serious injury, or equipment damage.

The equipment described in this manual uses R-454B refrigerant which is flammable (A2L). Use ONLY R-454B rated service equipment and components. For specific handling concerns with R-454B, contact your local representative.

Copyright

This document and the information in it are the property of Trane, and may not be used or reproduced in whole or in part without written permission. Trane reserves the right to revise this publication at any time, and to make changes to its content without obligation to notify any person of such revision or change.

Trademarks

All trademarks referenced in this document are the trademarks of their respective owners.

Table of Contents

General Information	5
Inspection	5
Parts List	5
Field Supplied Part	5
Installation	6
Standard Economizer	6
Low Leak Economizer (Downflow Units Only)	9
Close Out Installation	10
Wiring Connection	11
Power Wiring	11
Control Wiring	12
Standard Economizer	12
Low Leak Economizer	13
Power Exhaust Operation and Settings	14
Standard Economizer	14
Low Leak Economizer	14

General Information

Carefully review installation instructions.

- Power Exhaust is designed for down flow applications.
- For horizontal applications, the power exhaust may be mounted on the horizontal return duct.

Note: The installing technician is responsible for the installation.

- Install the economizer and verify functionality before installing the power exhaust.

Inspection

1. Unpack all components of the kit.
2. Check carefully for shipping damage. If any damage is found, report it immediately, and file a claim against the transportation company.

Parts List

Figure 1. Major power exhaust components

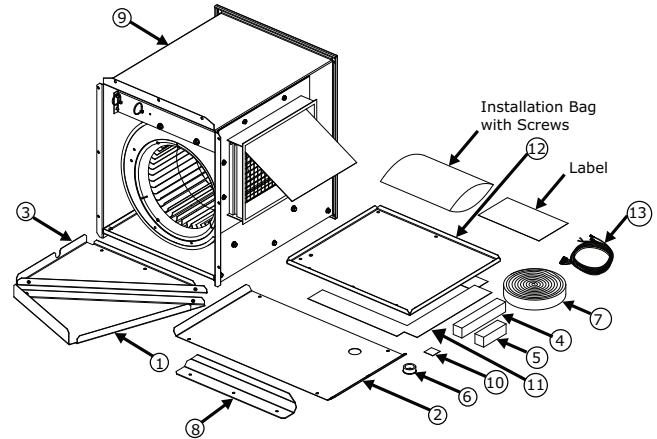

Table 1. Major power exhaust components

Item	Item Description	Quantity
9	Power Exhaust assembly	1
3	Internal block-off, left	1
1	Internal block-off, Right	1
8	Power exhaust alignment bracket	1
2	Internal block-off, Center	1
6	0.81-inch ID Bushing	1
11	2-inch aluminum tape	3
10	Label	1
4 and 5	Insulation	1
12	Top block off assembly	1
7	Gasket roll	
13	Low leak Economizer harness	1

Field Supplied Part

NOTICE

Corrosion Damage!
 Failure to use recommended caulking/sealant could cause corrosion related failures to refrigerant components.

1 - Tube Sealant - Trane recommends Sikaflex 221 (SEL00439).

Installation

⚠ WARNING

Hazardous Service Procedures!

Failure to follow all precautions in this manual and on the tags, stickers, and labels could result in death or serious injury.

Technicians, in order to protect themselves from potential electrical, mechanical, and chemical hazards, **MUST** follow precautions in this manual and on the tags, stickers, and labels, as well as the following instructions: Unless specified otherwise, disconnect all electrical power including remote disconnect and discharge all energy storing devices such as capacitors before servicing. Follow proper lockout/tagout procedures to ensure the power can not be inadvertently energized. When necessary to work with live electrical components, have a qualified licensed electrician or other individual who has been trained in handling live electrical components perform these tasks.

Standard Economizer

⚠ WARNING

Hazardous Voltage w/Capacitors!

Failure to disconnect power and discharge capacitors before servicing could result in death or serious injury. Disconnect all electric power, including remote disconnects and discharge all motor start/run capacitors before servicing. Follow proper lockout/tagout procedures to ensure the power cannot be inadvertently energized. Verify with a CAT III or IV voltmeter rated per NFPA 70E that all capacitors have discharged.

1. Open and lock unit disconnect before attempting to install this accessory.
2. Remove the top cover, access panel, control box access panel, horizontal access panel from the unit. See [Figure 2, p. 6](#).
3. Remove economizer duct block-off and discard. See [Figure 2, p. 6](#).

Figure 2. Remove access panels and top cover

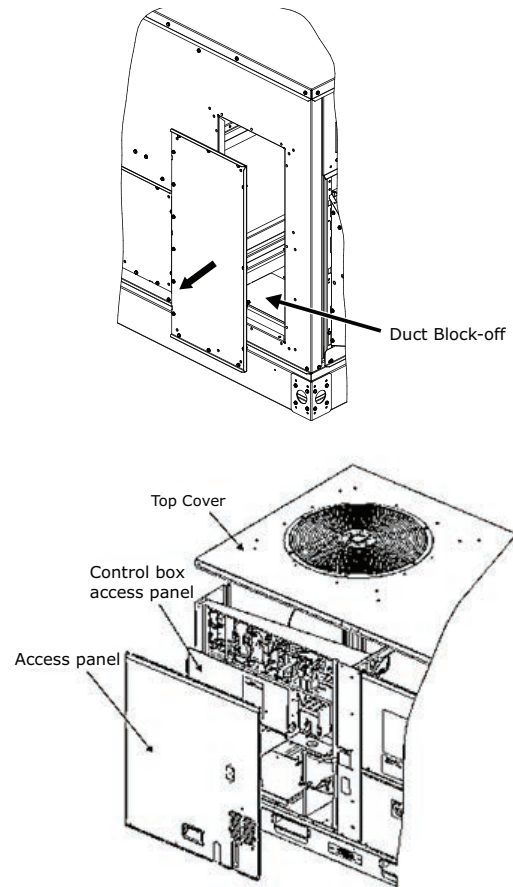

4. Remove packing material and parts from the box.
5. Build internal hood assembly as shown in [Figure 3, p. 6](#):
 - a. Attach 2 to 1 and 3 using 4 screws.
 - b. Apply gasket 4 and 5 to 1 and 3 respectively as shown in [Figure 3, p. 6](#) and [Figure 4, p. 7](#).

Figure 3. Internal hood assembly

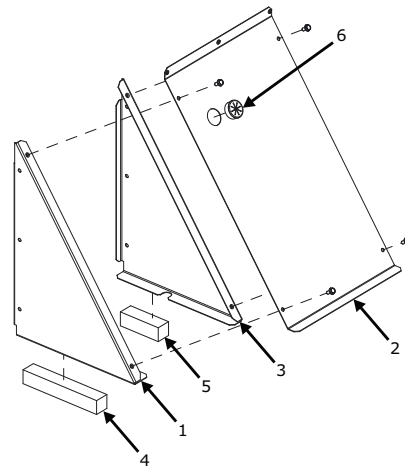
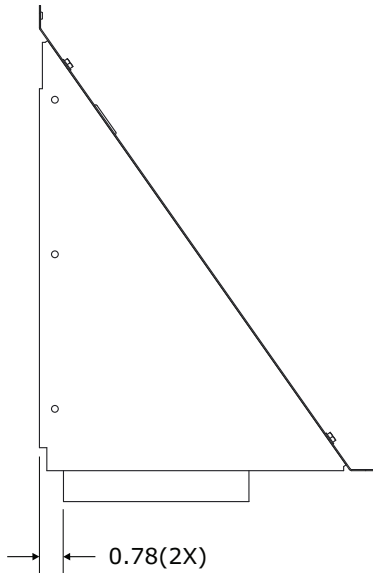
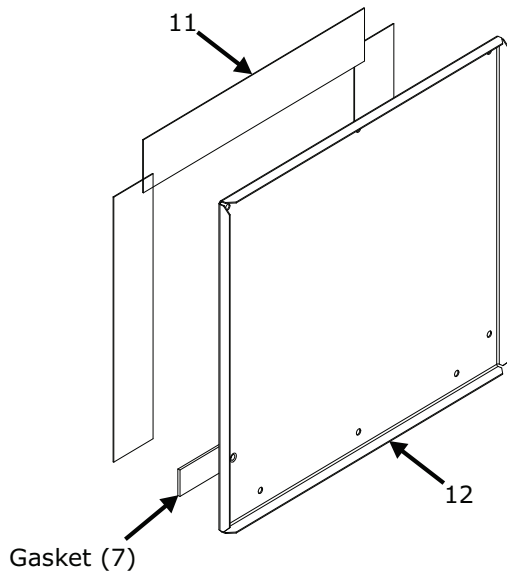

Figure 4. Bottom gasket installation



6. Build top block off assembly as shown in [Figure 5, p. 7](#):
 - a. Apply gasket 7 to the bottom of 12.
 - b. Apply 11 to prevent insulation from coming off.

Figure 5. Build top block-off assembly



7. Using six screws secure the internal hood assembly built in [Step 5](#) to side flanges of return opening. See [Figure 6, p. 7](#).

Figure 6. Attach internal hood assembly to unit

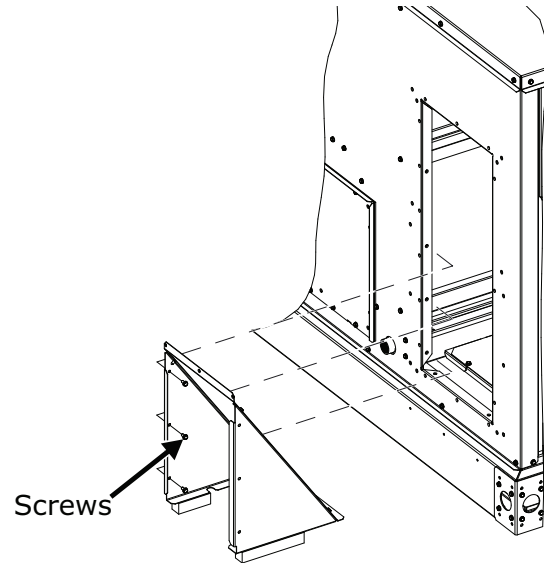

8. Apply gasket 14 to return opening around the dimples as shown in [Figure 7, p. 7](#).

Figure 7. Apply gasket

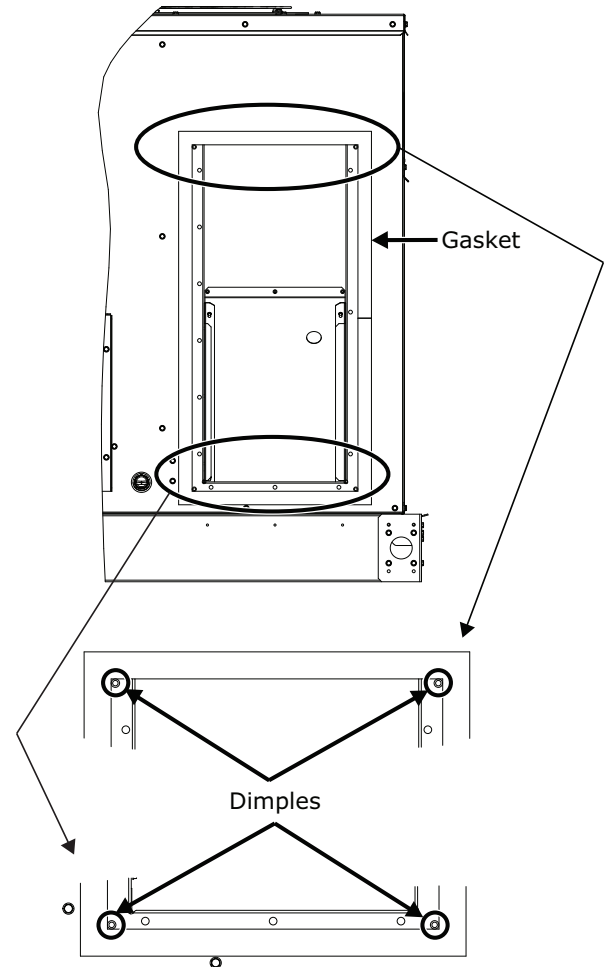

Installation

9. Attach support and alignment bracket to base rail using three screws. See [Figure 8, p. 8](#).

Figure 8. Install support and alignment bracket

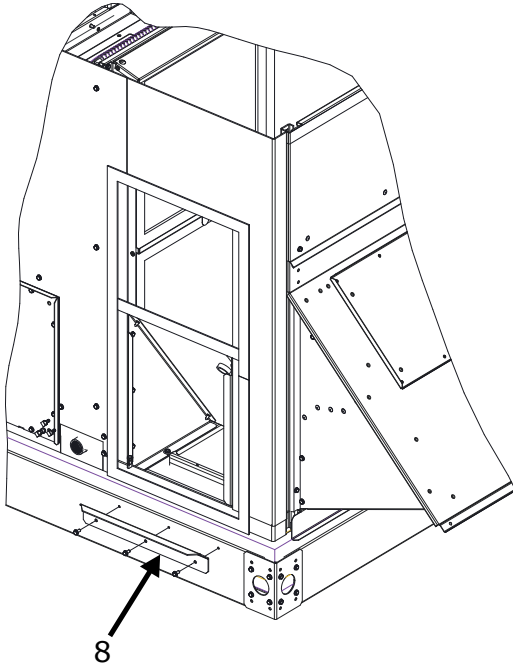

13. Install power exhaust assembly onto the side of unit using 6 screws. See [Figure 10, p. 8](#).

Figure 10. Attach power exhaust to side of unit

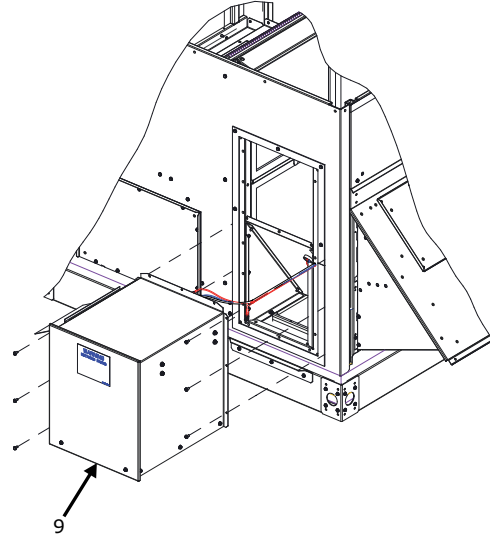

10. Set the power exhaust housing adjacent to the return duct opening.
11. Uncoil the wires and route them through the grommet in the internal block off (feed terminals through bushing one at a time). See [Figure 9, p. 8](#).
12. Insert wire tie into closest hole in the economizer front panel and secure the power and control wires. See [Figure 9, p. 8](#).

Figure 9. Standard economizer wire routing

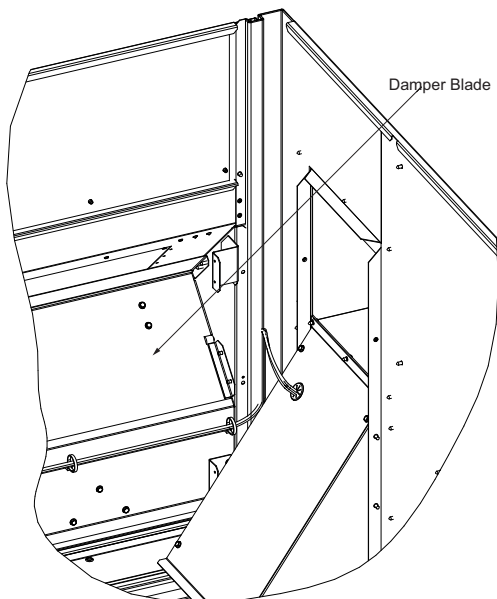

14. Using 8 screws attach horizontal return block-off to unit end panel. See [Figure 11, p. 8](#).

Figure 11. Attach horizontal return block-off

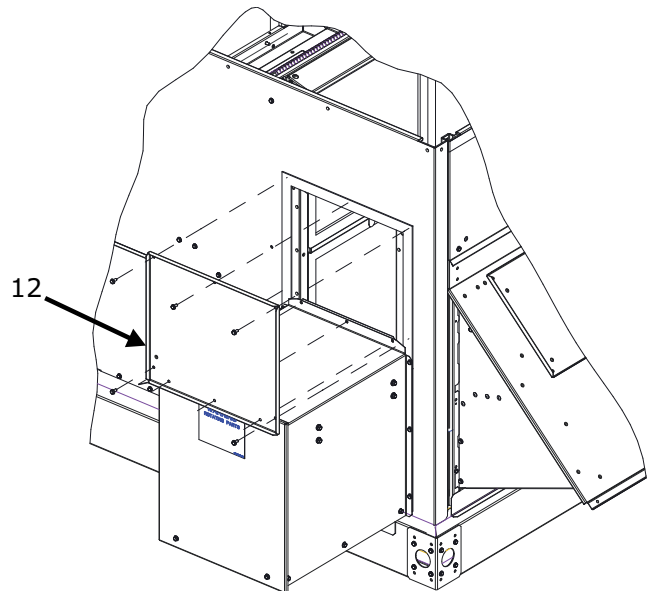

- Using field supplied silicone sealant, seal each corner of the power exhaust as well as all seams and make sure they are all water-tight. See [Figure 12, p. 9](#).

Figure 12. Seal seams and corners

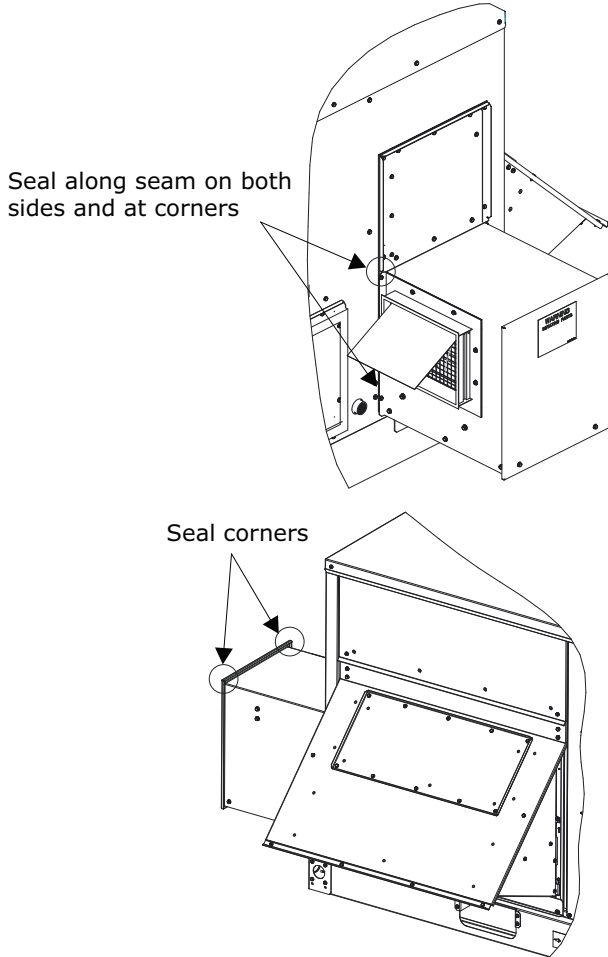

- Proceed to [“Wiring Connection,” p. 11](#) for wire routing and connections.
- Do not adjust damper blade manually while installing power exhaust and during wire routing and connections.

Low Leak Economizer (Downflow Units Only)

⚠ WARNING

Hazardous Voltage w/Capacitors!

Failure to disconnect power and discharge capacitors before servicing could result in death or serious injury. Disconnect all electric power, including remote disconnects and discharge all motor start/run capacitors before servicing. Follow proper lockout/tagout procedures to ensure the power cannot be inadvertently energized. Verify with a CAT III or IV voltmeter rated per NFPA 70E that all capacitors have discharged.

- Open and lock unit disconnect.
- Remove the parts from the box.
- Discard all the items except item 9. Refer to [Figure 1, p. 5](#) and [Table 1, p. 5](#).
- Remove block off and discard as shown in [Figure 13, p. 9](#).

Figure 13. Remove block-off

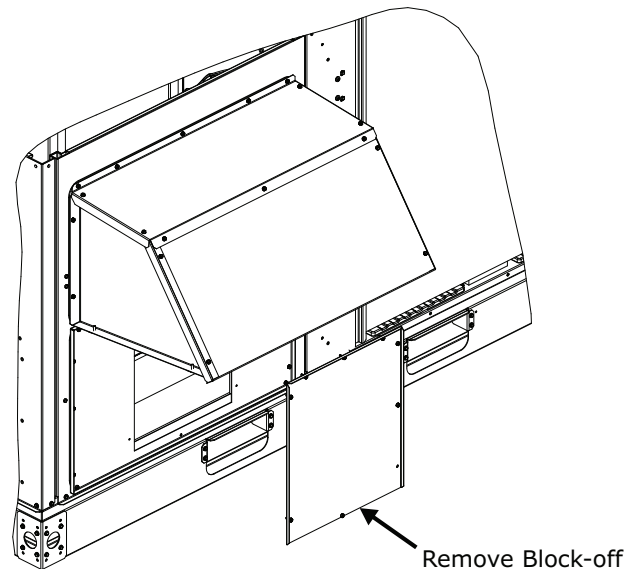

- Apply gasket to the power exhaust assembly as shown in [Figure 14, p. 10](#).

Installation

Figure 14. Apply gasket

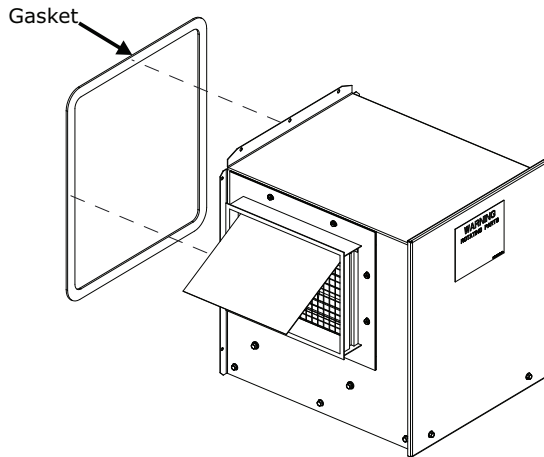

6. Install the power exhaust onto the unit using 9 screws as shown in [Figure 15, p. 10](#).

Figure 15. Assemble power exhaust

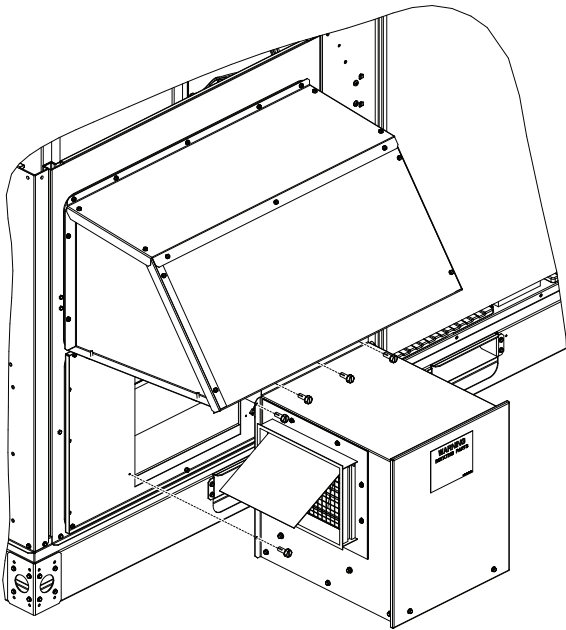

7. Using field supplied silicone sealant, seal all seams on the power exhaust and make sure they are all water-tight. See [Figure 16, p. 10](#).

Figure 16. Seal seams on power exhaust

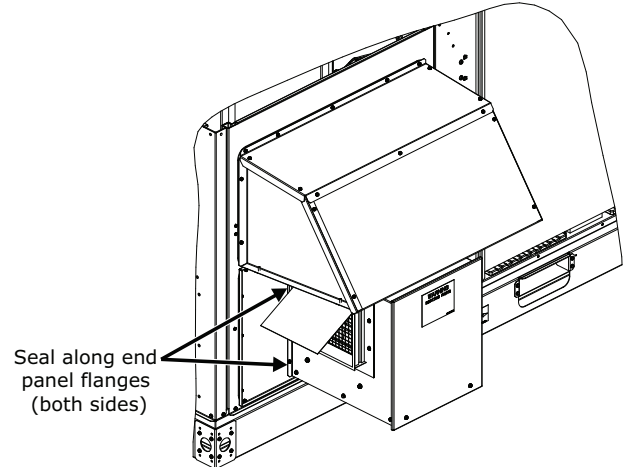

8. Proceed to "[Wiring Connection,](#)" [p. 11](#) for wire routing and connections.

Close Out Installation

Once all the wiring connections are made, replace the filter access panel and close the unit disconnect switch.

Wiring Connection

Power Wiring

⚠ WARNING

Hazardous Voltage w/Capacitors!

Failure to disconnect power and discharge capacitors before servicing could result in death or serious injury. Disconnect all electric power, including remote disconnects and discharge all motor start/run capacitors before servicing. Follow proper lockout/tagout procedures to ensure the power cannot be inadvertently energized. Verify with a CAT III or IV voltmeter rated per NFPA 70E that all capacitors have discharged.

1. Open and lock unit disconnect.
2. Remove the top cover, access panel and control box access panel from the unit.
3. Route the power harness.
 - a. **Standard Economizer:** Route power harness 1M and 3M through wire ties in the indoor section all the way to the control box, and connect them to HTB as shown in [Figure 17, p. 11](#) and [Figure 18, p. 11](#).

Figure 17. Power wiring for standard economizer

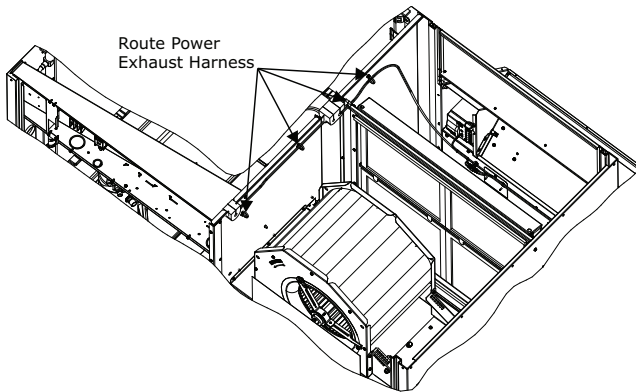
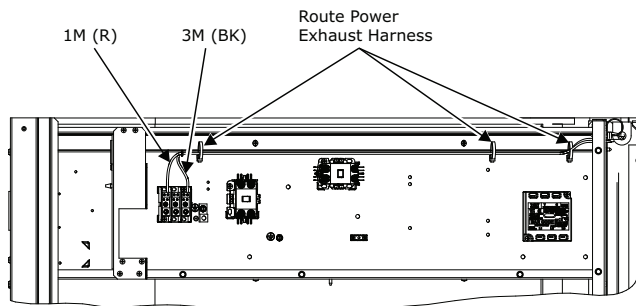

Figure 18. Connect power wiring to HTB



b. Low Leak Economizer:

- i. Take the low leak economizer labeled harness out of the box and route the harness as shown in [Figure 19, p. 11](#) from the control box to the return section of the economizer.

Figure 19. Power wiring for low leak economizer

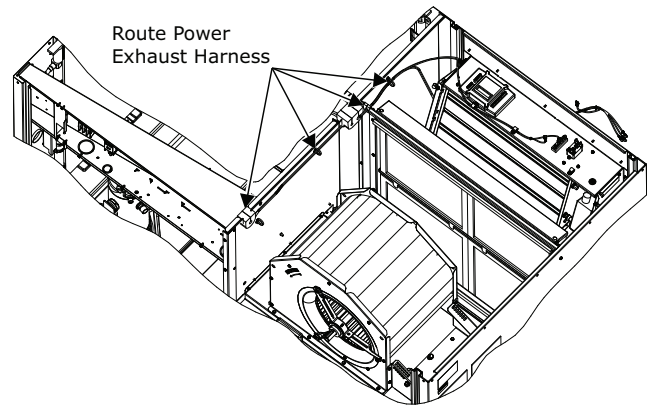

- ii. Connect the power harness 1M and 3M to HTB in the control box (see [Figure 19, p. 11](#)) and route through the control box and indoor section wire ties and along the side of economizer and pass through the bushing as shown in [Figure 19, p. 11](#) and [Figure 20, p. 11](#).

Figure 20. Power wiring through low leak economizer

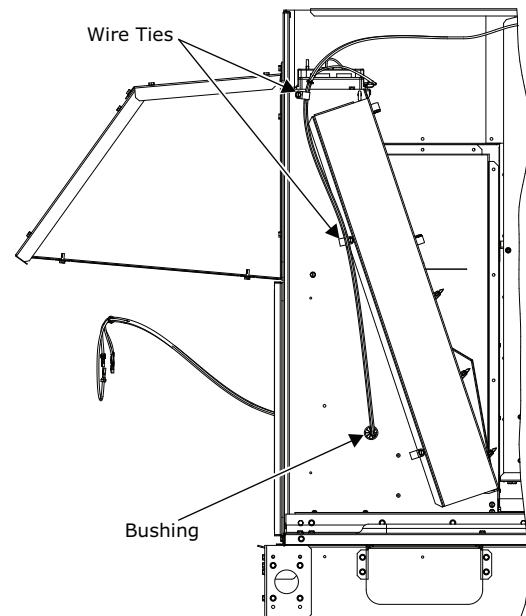

4. Take the back panel off from the power exhaust, remove the 4 wire harness connected and discard.
5. Connect the supplied harness to respective exhaust fan relay (XFR) and capacitor exhaust fan (CFX) as shown [Figure 21, p. 12](#).

Wiring Connection

Figure 21. Wiring connection - power exhaust

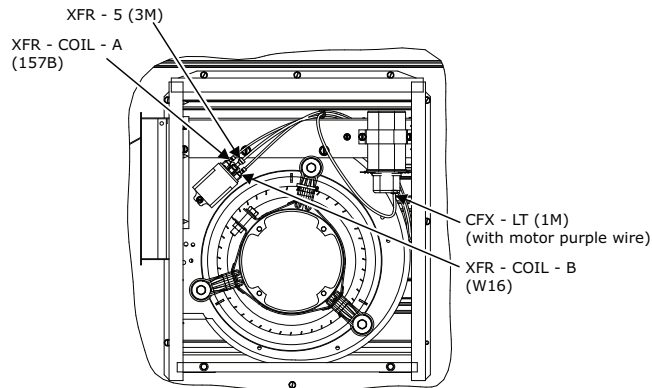
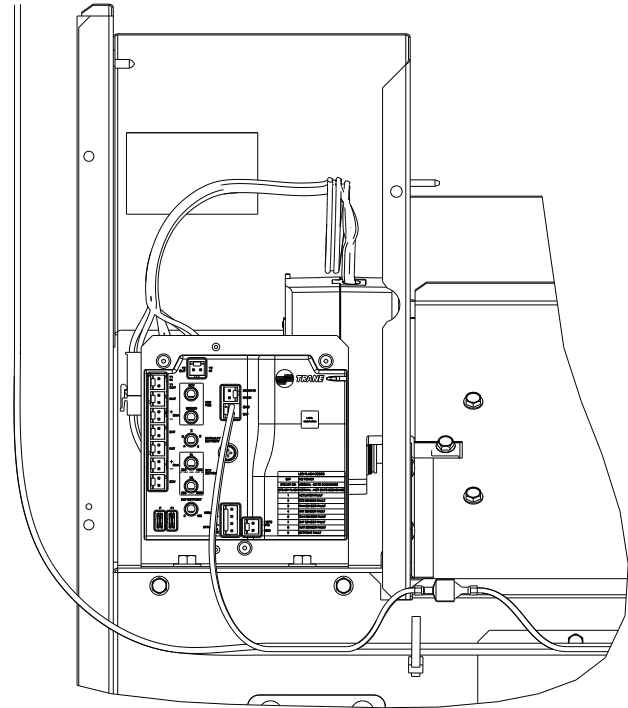

Figure 22. Connecting to RTEM



Control Wiring

⚠ WARNING

Hazardous Voltage w/Capacitors!

Failure to disconnect power and discharge capacitors before servicing could result in death or serious injury. Disconnect all electric power, including remote disconnects and discharge all motor start/run capacitors before servicing. Follow proper lockout/tagout procedures to ensure the power cannot be inadvertently energized. Verify with a CAT III or IV voltmeter rated per NFPA 70E that all capacitors have discharged.

Standard Economizer

Note: Refer to [Figure 24, p. 13](#) for connections.

Connect power exhaust PPF7 plug, wires #157A and 158A, to EXF on actuator module. See [Figure 22, p. 12](#).

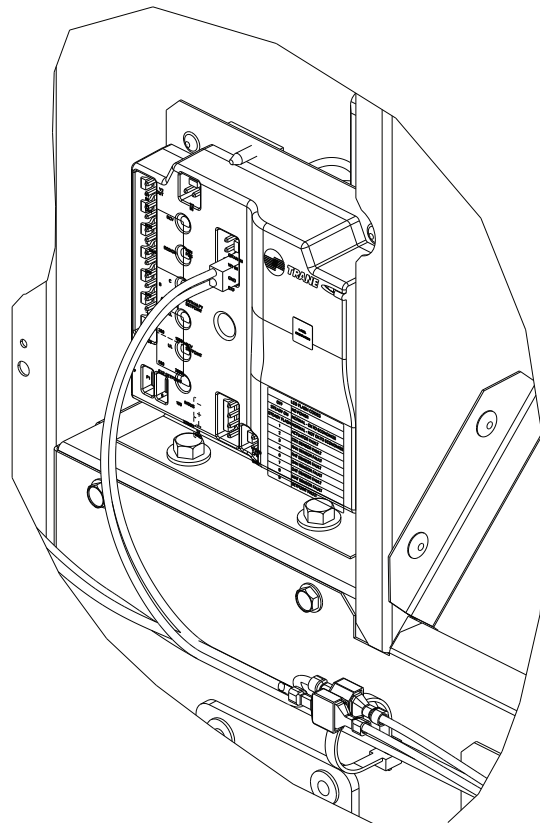

Low Leak Economizer

Note: Refer to [Figure 24, p. 13](#) for connections.

1. Connect wire W16 to LTB2-2 located next to the JADE controller.
2. Connect wire 157B to wire 157C which is connected to EXH1 on the economizer controller.

Figure 23. JADE controller connections

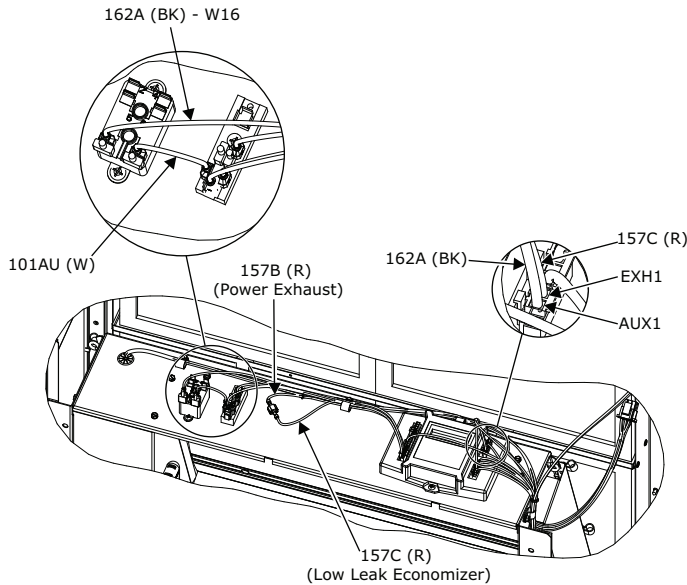
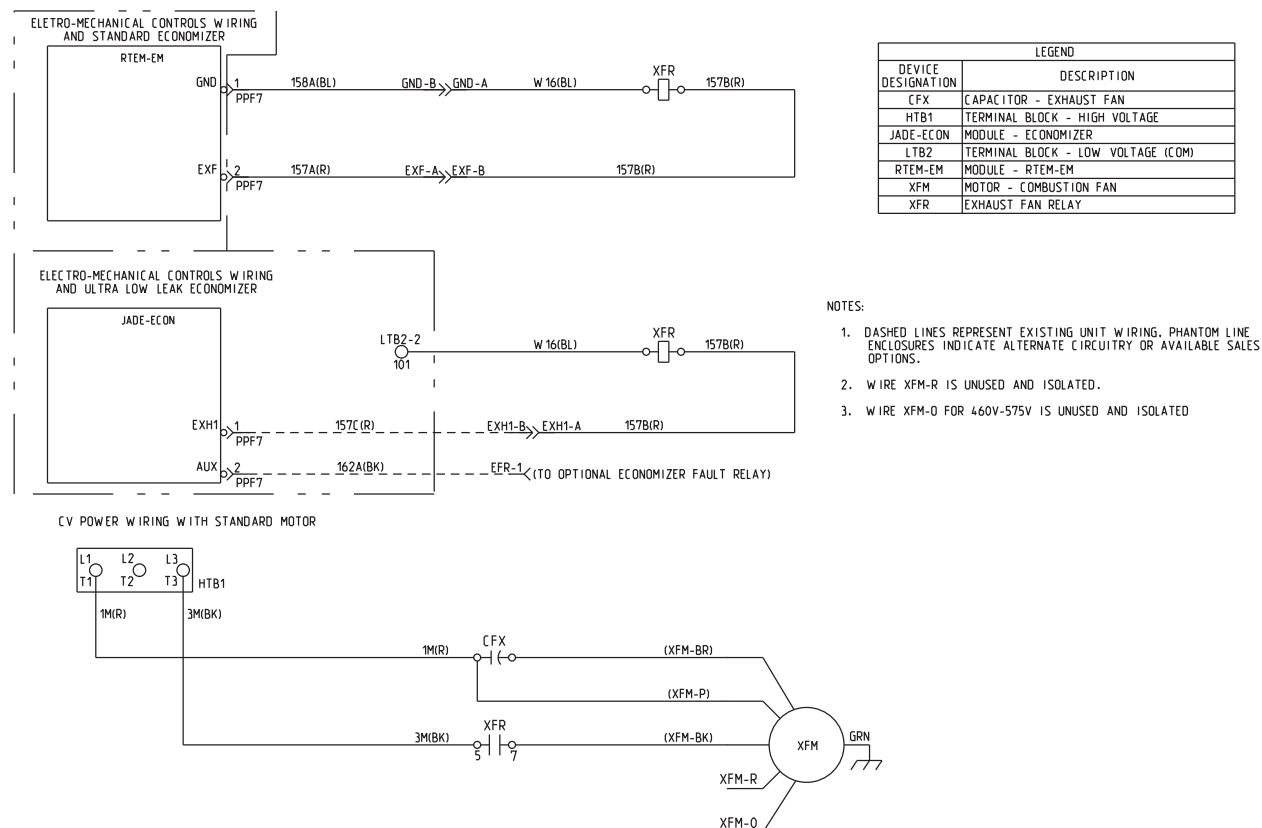

Figure 24. Wiring diagram



Power Exhaust Operation and Settings

Standard Economizer

The Power Exhaust setpoint (point at which the Power Exhaust is turned on) is adjustable from 0% to 100% economizer damper outside air setting, corresponding to the setting of the "exhaust setpoint" potentiometer on the RTEM-EM. The Power Exhaust is turned on when the indoor blower is running and the damper position is greater than the Power Exhaust setpoint.

Low Leak Economizer

The Power Exhaust setpoint (point at which the Power Exhaust is turned on) is adjustable from 0% to 100% economizer damper outside air setting, corresponding to the setting of the **EXH1 SET** value in the **SETPOINTS** menu in the **JADE** controller.

The **JADE** display will display **EXH1 OUT** as **ON** when the Power Exhaust is turned on. Power Exhaust is turned on when the damper position is greater than the Power Exhaust setpoint.

Trane and American Standard create comfortable, energy efficient indoor environments for commercial and residential applications. For more information, please visit trane.com or americanstandardair.com.

Trane and American Standard have a policy of continuous product and product data improvement and reserve the right to change design and specifications without notice. We are committed to using environmentally conscious print practices.