

## Installation Instructions

# Drain Pan Overflow Switch

Foundation™ Packaged Rooftop Units

3 to 5 Tons

Model Number: BAYCOSW320\*  
Used With: E/GB\*036-060  
E/GD\*036-060

### SAFETY WARNING

Only qualified personnel should install and service the equipment. The installation, starting up, and servicing of heating, ventilating, and air-conditioning equipment can be hazardous and requires specific knowledge and training. Improperly installed, adjusted or altered equipment by an unqualified person could result in death or serious injury. When working on the equipment, observe all precautions in the literature and on the tags, stickers, and labels that are attached to the equipment.

August 2024

ACC-SVN271B-EN

©2024

## Warnings, Cautions, and Notices

Read this manual thoroughly before operating or servicing this unit. Safety advisories appear throughout this manual as required. Your personal safety and the proper operation of this machine depend upon the strict observance of these precautions.

The three types of advisories are defined as follows:

### WARNING

Indicates a potentially hazardous situation which, if not avoided, could result in death or serious injury.

### CAUTION

Indicates a potentially hazardous situation which, if not avoided, could result in minor or moderate injury. It could also be used to alert against unsafe practices.

### NOTICE

Indicates a situation that could result in equipment or property-damage only accidents.

### Important Environmental Concerns

Scientific research has shown that certain man-made chemicals can affect the earth's naturally occurring stratospheric ozone layer when released to the atmosphere. In particular, several of the identified chemicals that may affect the ozone layer are refrigerants that contain Chlorine, Fluorine and Carbon (CFCs) and those containing Hydrogen, Chlorine, Fluorine and Carbon (HCFCs). Not all refrigerants containing these compounds have the same potential impact to the environment. Trane advocates the responsible handling of all refrigerants.

### Important Responsible Refrigerant Practices

Trane believes that responsible refrigerant practices are important to the environment, our customers, and the air conditioning industry. All technicians who handle refrigerants must be certified according to local rules. For the USA, the Federal Clean Air Act (Section 608) sets forth the requirements for handling, reclaiming, recovering and recycling of certain refrigerants and the equipment that is used in these service procedures. In addition, some states or municipalities may have additional requirements that must also be adhered to for responsible management of refrigerants. Know the applicable laws and follow them.

2

### WARNING

#### Proper Field Wiring and Grounding Required!

Failure to follow code could result in death or serious injury. All field wiring MUST be performed by qualified personnel. Improperly installed and grounded field wiring poses FIRE and ELECTROCUTION hazards. To avoid these hazards, you MUST follow requirements for field wiring installation and grounding as described in NEC and your local/state/national electrical codes.

### WARNING

#### Personal Protective Equipment (PPE) Required!

Failure to wear proper PPE for the job being undertaken could result in death or serious injury. Technicians, in order to protect themselves from potential electrical, mechanical, and chemical hazards, MUST follow precautions in this manual and on the tags, stickers, and labels, as well as the instructions below:

- Before installing/servicing this unit, technicians MUST put on all PPE required for the work being undertaken (Examples; cut resistant gloves/sleeves, butyl gloves, safety glasses, hard hat/bump cap, fall protection, electrical PPE and arc flash clothing). ALWAYS refer to appropriate Safety Data Sheets (SDS) and OSHA guidelines for proper PPE.
- When working with or around hazardous chemicals, ALWAYS refer to the appropriate SDS and OSHA/GHS (Global Harmonized System of Classification and Labeling of Chemicals) guidelines for information on allowable personal exposure levels, proper respiratory protection and handling instructions.
- If there is a risk of energized electrical contact, arc, or flash, technicians MUST put on all PPE in accordance with OSHA, NFPA 70E, or other country-specific requirements for arc flash protection, PRIOR to servicing the unit. NEVER PERFORM ANY SWITCHING, DISCONNECTING, OR VOLTAGE TESTING WITHOUT PROPER ELECTRICAL PPE AND ARC FLASH CLOTHING. ENSURE ELECTRICAL METERS AND EQUIPMENT ARE PROPERLY RATED FOR INTENDED VOLTAGE.

3

### WARNING

#### Follow EHS Policies!

Failure to follow instructions below could result in death or serious injury.

- All Trane personnel must follow the company's Environmental, Health and Safety (EHS) policies when performing work such as hot work, electrical, fall protection, lockout/tagout, refrigerant handling, etc. Where local regulations are more stringent than these policies, those regulations supersede these policies.
- Non-Trane personnel should always follow local regulations.

### WARNING

#### R-454B Flammable A2L Refrigerant!

Failure to use proper equipment or components as described below could result in equipment failure, and possibly fire, which could result in death, serious injury, or equipment damage. The equipment described in this manual uses R-454B refrigerant which is flammable (A2L). Use ONLY R-454B rated service equipment and components. For specific handling concerns with R-454B, contact your local representative.

### Copyright

This document and the information in it are the property of Trane, and may not be used or reproduced in whole or in part without written permission. Trane reserves the right to revise this publication at any time, and to make changes to its content without obligation to notify any person of such revision or change.

### Trademarks

All trademarks referenced in this document are the trademarks of their respective owners.

### Inspection

1. Check carefully for shipping damage. If any damage is found, report it immediately, and file a claim against the transportation company. Replace damaged parts with authorized parts only.

4

2. Compare the order number on the shipping label with the accessory identification information on the ordering and shipping documents to verify that the correct accessory has been received.

## Parts List

Table 1. Parts list

Qty	Description
1	DP Float Switch Mounting Bracket
1	Drain Pan Overflow Switch
1	Time Delay, Solid State
1	Relay, SPDT, 30 Amp
2	Harness assembly
	Phillips panhead screws 0.5-inch thread rolling zinc plate 8-32
	Phillips panhead screw 1-inch thread rolling zinc plate 8-32
	Wire ties

## Installation

### WARNING

#### Hazardous Voltage w/Capacitors!

Failure to disconnect power and discharge capacitors before servicing could result in death or serious injury. Disconnect all electric power, including remote disconnects and discharge all motor start/run capacitors before servicing. Follow proper lockout/ tagout procedures to ensure the power cannot be inadvertently energized. Verify with a CAT III or IV voltmeter rated per NFPA 70E that all capacitors have discharged.

5

1. Open and lock unit disconnect.
2. Remove the screws around the unit top panel assembly. Refer to Figure 1.

Figure 1. Remove screws around top panel assembly

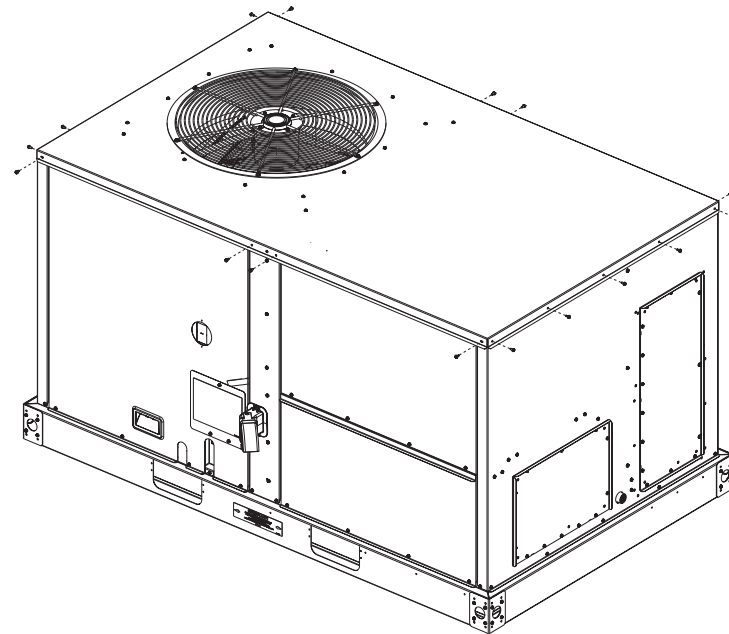

6

3. Rotate the top assembly. Refer to Figure 2.

Figure 2. Rotate top assembly

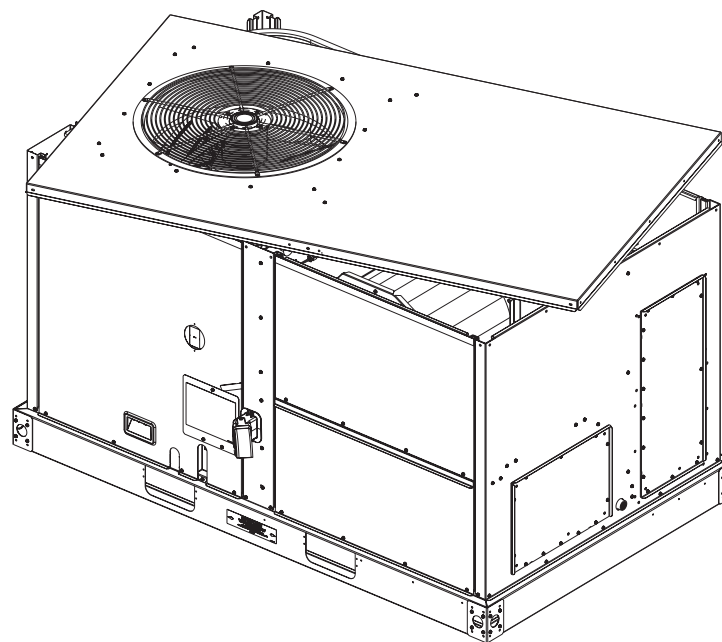

7

4. Remove the indoor section access panel. Refer to Figure 3.

Figure 3. Remove indoor section access panel

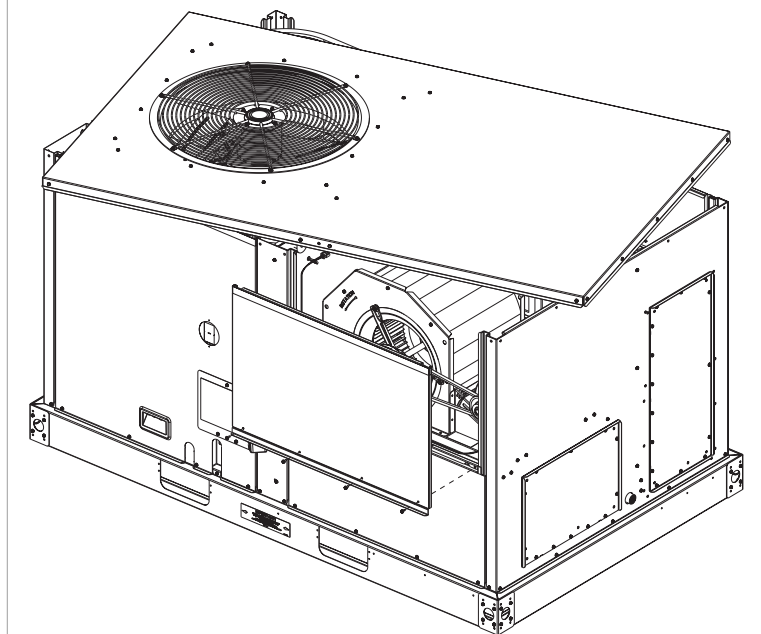

8

5. Remove the screw from the top right hand side corner of the supply panel. Refer to [Figure 4](#).

**Figure 4. Remove screw from supply panel**

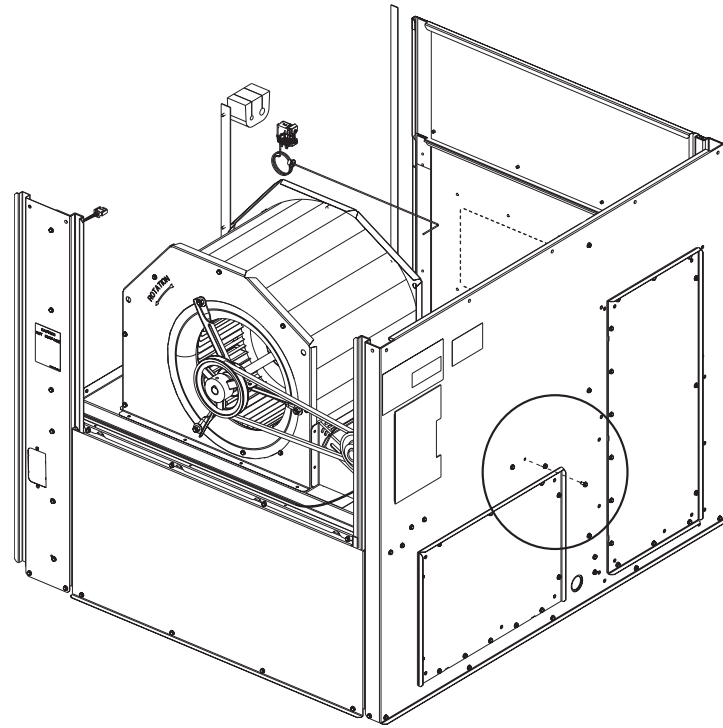

9

6. Locate drain pan below the evaporator coil and place the switch in the slot provided in the overflow bracket. See [Figure 6](#). Install the drain pan overflow switch using the screw removed in previous step. Refer to [Figure 5](#).

**Figure 5. Install drain pan switch**

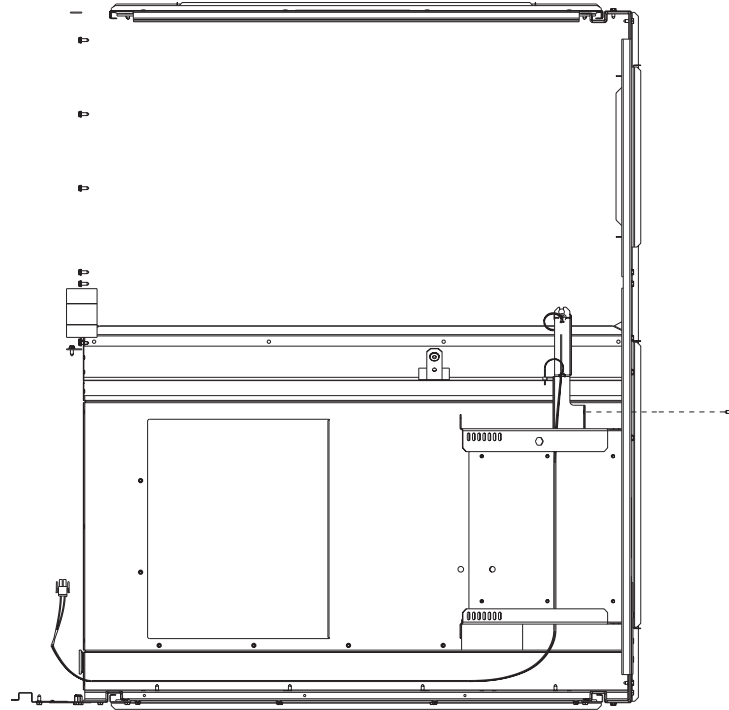

10

7. Connect PPF99 from the harness kit to the connector on the switch pigtail.

**Figure 6. Switch pigtail connection**

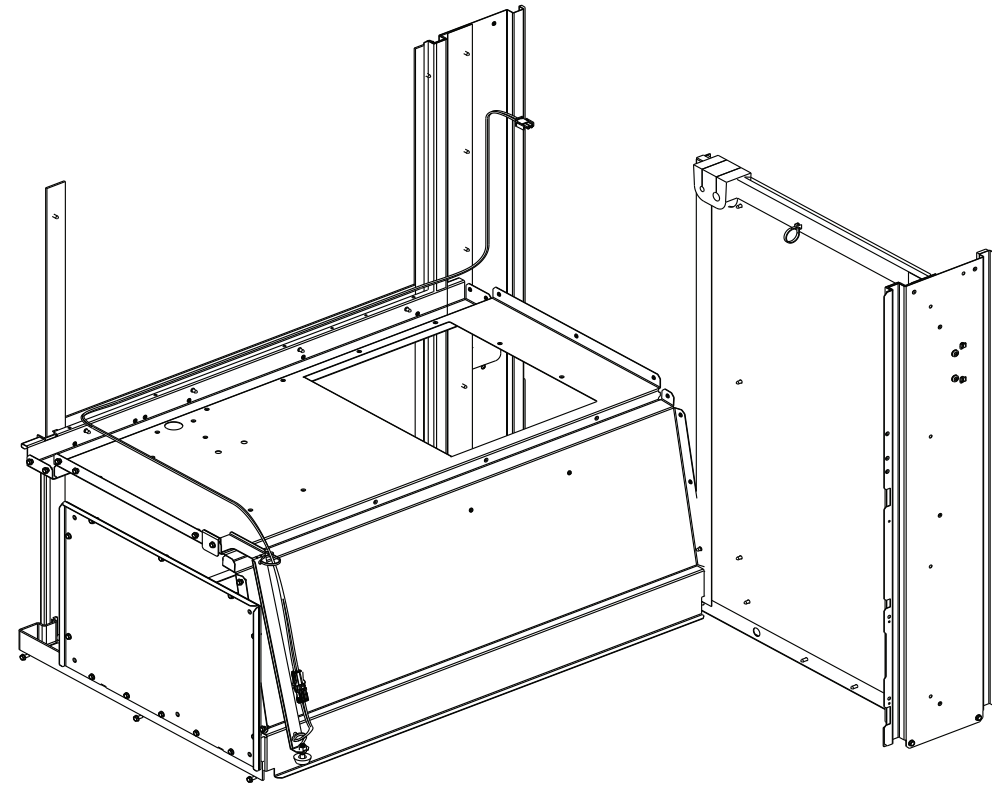

11

8. Install the relay and timer on the left side of the control panel. Refer to [Figure 7](#).

**Figure 7. Install relay and timer**

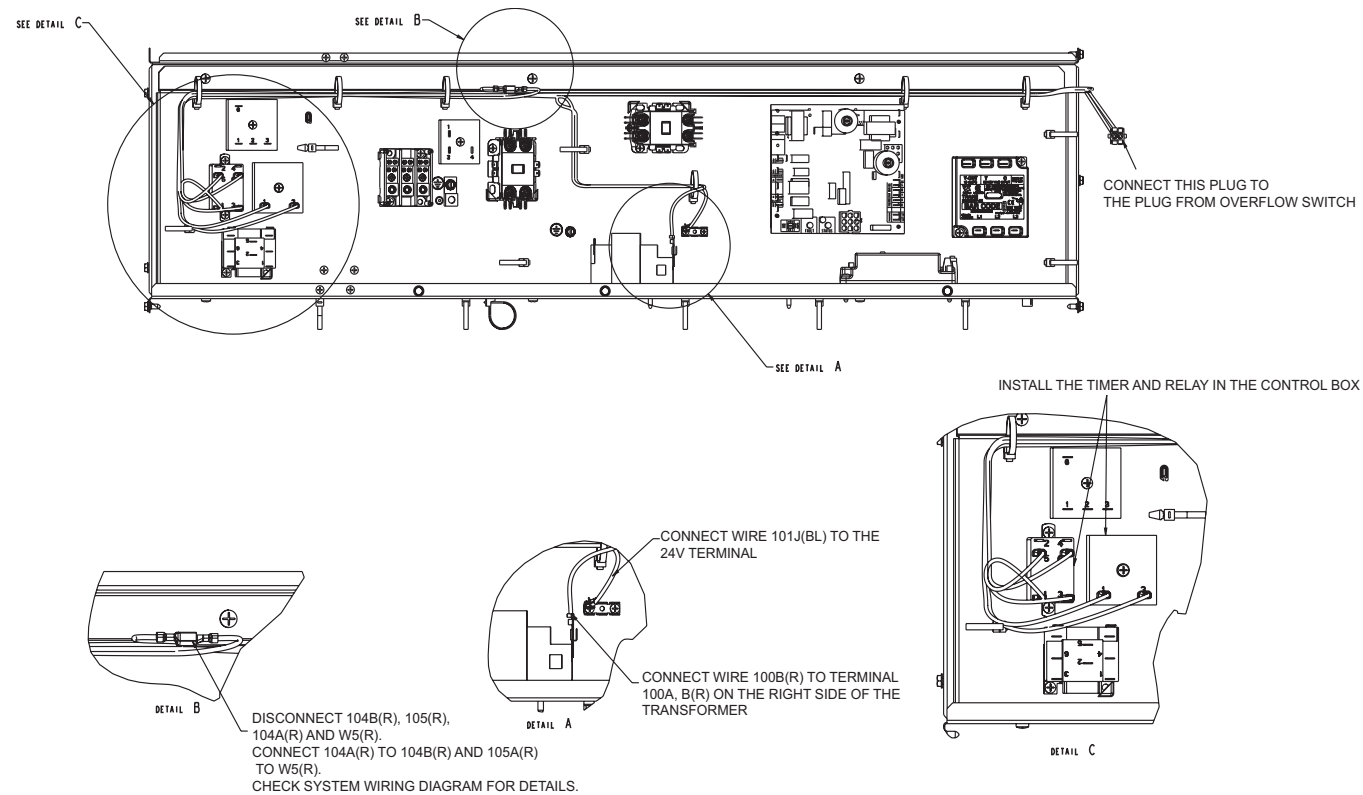

12

9. Route drain pan overflow switch wiring along the indoor fan deck. Refer to [Figure 8](#) and [Figure 9](#).

**Figure 8. Route drain pan overflow switch wiring**

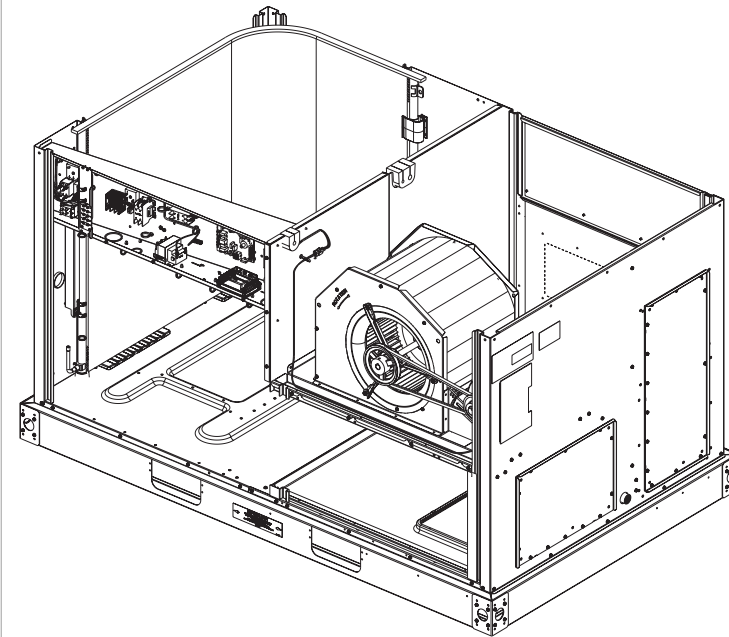

13

**Figure 9. Route drain pan overflow switch wiring - top view**

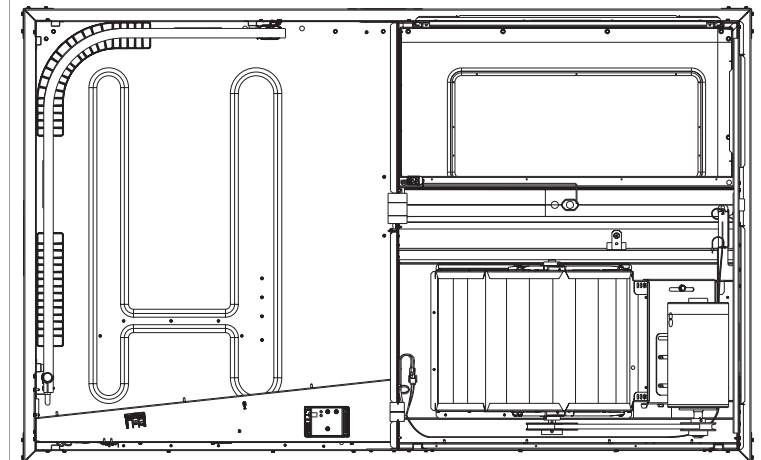

Trane and American Standard create comfortable, energy efficient indoor environments for commercial and residential applications. For more information, please visit [trane.com](http://trane.com) or [americanstandardair.com](http://americanstandardair.com).

Trane and American Standard have a policy of continuous product and product data improvement and reserve the right to change design and specifications without notice. We are committed to using environmentally conscious print practices.

ACC-SVN271B-EN 23 Aug 2024  
Supersedes ACC-SVN271A-EN (Jul 2024)

©2024