

# Installation Instructions

# **LP Conversion Kit**

## Precedent™ Packaged Rooftop Units

## 6 to 25 Tons

**Model Number:**  
FIALPKTM\*\*\*

**Used With:**  
Precedent with modulating gas heat (Digit 10 = B)

### **▲ SAFETY WARNING**

Only qualified personnel should install and service the equipment. The installation, starting up, and servicing of heating, ventilating, and air-conditioning equipment can be hazardous and requires specific knowledge and training. Improperly installed, adjusted or altered equipment by an unqualified person could result in death or serious injury. When working on the equipment, observe all precautions in the literature and on the tags, stickers, and labels that are attached to the equipment.

# Introduction

Read this manual thoroughly before operating or servicing this unit.

## Warnings, Cautions, and Notices

Safety advisories appear throughout this manual as required. Your personal safety and the proper operation of this machine depend upon the strict observance of these precautions.

The three types of advisories are defined as follows:



Indicates a potentially hazardous situation which, if not avoided, could result in death or serious injury.



Indicates a potentially hazardous situation which, if not avoided, could result in minor or moderate injury. It could also be used to alert against unsafe practices.

**NOTICE**

Indicates a situation that could result in equipment or property-damage only accidents.

## Important Environmental Concerns

Scientific research has shown that certain man-made chemicals can affect the earth's naturally occurring stratospheric ozone layer when released to the atmosphere. In particular, several of the identified chemicals that may affect the ozone layer are refrigerants that contain Chlorine, Fluorine and Carbon (CFCs) and those containing Hydrogen, Chlorine, Fluorine and Carbon (HCFCs). Not all refrigerants containing these compounds have the same potential impact to the environment. Trane advocates the responsible handling of all refrigerants.

## Important Responsible Refrigerant Practices

Trane believes that responsible refrigerant practices are important to the environment, our customers, and the air conditioning industry. All technicians who handle refrigerants must be certified according to local rules. For the USA, the Federal Clean Air Act (Section 608) sets forth the requirements for handling, reclaiming, recovering and recycling of certain refrigerants and the equipment that is used in these service procedures. In addition, some states or municipalities may have additional requirements that must also be adhered to for responsible management of refrigerants. Know the applicable laws and follow them.

### **WARNING**

#### **Proper Field Wiring and Grounding Required!**

Failure to follow code could result in death or serious injury.

**All field wiring MUST be performed by qualified personnel. Improperly installed and grounded field wiring poses FIRE and ELECTROCUTION hazards. To avoid these hazards, you MUST follow requirements for field wiring installation and grounding as described in NEC and your local/state/national electrical codes.**

### **WARNING**

#### **Personal Protective Equipment (PPE) Required!**

Failure to wear proper PPE for the job being undertaken could result in death or serious injury.

Technicians, in order to protect themselves from potential electrical, mechanical, and chemical hazards, **MUST follow precautions in this manual and on the tags, stickers, and labels, as well as the instructions below:**

- **Before installing/servicing this unit, technicians MUST put on all PPE required for the work being undertaken (Examples; cut resistant gloves/sleeves, butyl gloves, safety glasses, hard hat/bump cap, fall protection, electrical PPE and arc flash clothing). ALWAYS refer to appropriate Safety Data Sheets (SDS) and OSHA guidelines for proper PPE.**
- **When working with or around hazardous chemicals, ALWAYS refer to the appropriate SDS and OSHA/GHS (Global Harmonized System of Classification and Labelling of Chemicals) guidelines for information on allowable personal exposure levels, proper respiratory protection and handling instructions.**
- **If there is a risk of energized electrical contact, arc, or flash, technicians MUST put on all PPE in accordance with OSHA, NFPA 70E, or other country-specific requirements for arc flash protection, PRIOR to servicing the unit. NEVER PERFORM ANY SWITCHING, DISCONNECTING, OR VOLTAGE TESTING WITHOUT PROPER ELECTRICAL PPE AND ARC FLASH CLOTHING. ENSURE ELECTRICAL METERS AND EQUIPMENT ARE PROPERLY RATED FOR INTENDED VOLTAGE.**

**⚠ WARNING****Follow EHS Policies!**

Failure to follow instructions below could result in death or serious injury.

- All Trane personnel must follow the company's Environmental, Health and Safety (EHS) policies when performing work such as hot work, electrical, fall protection, lockout/tagout, refrigerant handling, etc. Where local regulations are more stringent than these policies, those regulations supersede these policies.
- Non-Trane personnel should always follow local regulations.

**⚠ WARNING****R-454B Flammable A2L Refrigerant!**

Failure to use proper equipment or components as described below could result in equipment failure, and possibly fire, which could result in death, serious injury, or equipment damage.

The equipment described in this manual uses R-454B refrigerant which is flammable (A2L). Use ONLY R-454B rated service equipment and components. For specific handling concerns with R-454B, contact your local representative.

**⚠ WARNING****Cancer and Reproductive Harm!**

This product can expose you to chemicals including lead and bisphenol A (BPA), which are known to the State of California to cause cancer and birth defects or other reproductive harm. For more information go to [www.P65Warnings.ca.gov](http://www.P65Warnings.ca.gov).

**Copyright**

This document and the information in it are the property of Trane, and may not be used or reproduced in whole or in part without written permission. Trane reserves the right to revise this publication at any time, and to make changes to its content without obligation to notify any person of such revision or change.

**Trademarks**

All trademarks referenced in this document are the trademarks of their respective owners.

**Revision History**

Table 1 - Updated gas orifice diameter values for FIALPKTM05\*-07\*.

# General Information

Carefully review installation instructions. These instructions describe converting natural gas package unit models from natural gas to propane (LP) gas.

**Important:** Gas type conversion is a critical procedure, so these instructions must be followed.

## Inspection

1. Unpack all components of the kit.
2. Check carefully for shipping damage. If any damage is found, report it immediately, and file a claim against the transportation company.

**Important:**

- Furnaces are shipped from the factory pre-configured for natural gas at 0 to 10,000 feet of elevation.
- For a specific furnace configuration, each kit will have all parts to complete the conversion. See [Table 1, p. 4](#) for the bill of materials for each individual kit. If there is a blank cell for the component, the component listed is not applicable to that specific kit.
- For a complete conversion, the gas orifices, circuit board ID chip, inducer plate, and spring kits must be applied. No pressure switches are included in the kits.

**Table 1. Parts list for natural gas to LP conversion kits – modulating gas – 0 to 10,000 feet elevation**

FIA Kit	Furnace Configuration				LP Kit Bill of Materials								Application Notes
	Furnace BTUH	Cabinet	Fuel	LP Turn Down Ratio	Gas Orifice (Diameter)	Gas Orifice (Qty)	VB1285 Program Chip (Heatco Part Number)	Inducer Plate Size (Ins.)	Inducer Gasket (Qty.)	Rivets (Qty.)	Spring Kits (Qty.)	Instructions ACC-SVN-269 (Qty.)	
FIALPKTM01*	80,000	B	LP	4:1	# 49 DS	2	3025.1 HP080 - 10 LP	2.313	1	—	2	1	—
FIALPKTM02*	120,000	B	LP	5:1	# 52 DS	4	3028.0 HP120 - 10 LP	2.438	1	—	2	1	—
FIALPKTM03*	150,000	B	LP	6:1	1.8 mm	4	3029.0 HP150 - 10 LP	2.688	1	—	2	1	—
FIALPKTM04*	200,000	B	LP	6:1	1.7 mm	6	3024.1 HP200 - 10 LP	3.375	1	—	2	1	—
FIALPKTM05*	240,000	B	LP	6:1	# 49 DS	6	3013.2 HP240 - 10 LP	3.625	1	—	2	1	—
FIALPKTM06*	150,000	C	LP	6:1	1.8 mm	4	3020.2 HQ150 - 10 LP	2.875	1	—	2	1	—
FIALPKTM07*	250,000	C	LP	6:1	# 48 DS	6	3012.1 HQ250 - 10 LP	4.500	1	—	2	1	—
FIALPKTM08*	250,000	D	LP	6:1	1.9 mm	6	3021.1 HR250 - 10 LP	2.375	1	7	2	1	12.5 ton only
FIALPKTM09*	250,000	D	LP	6:1	1.9 mm	6	3017.1 HR250 - 10 LP	2.438	1	7	2	1	—
FIALPKTM010*	400,000	D	LP	6:1	2.05 mm	8	3011.3 HR400 - 10 LP	4.625	1	7	2	1	—

# Installation

**Figure 1. Location of gas heat components and connections – B and C cabinet**

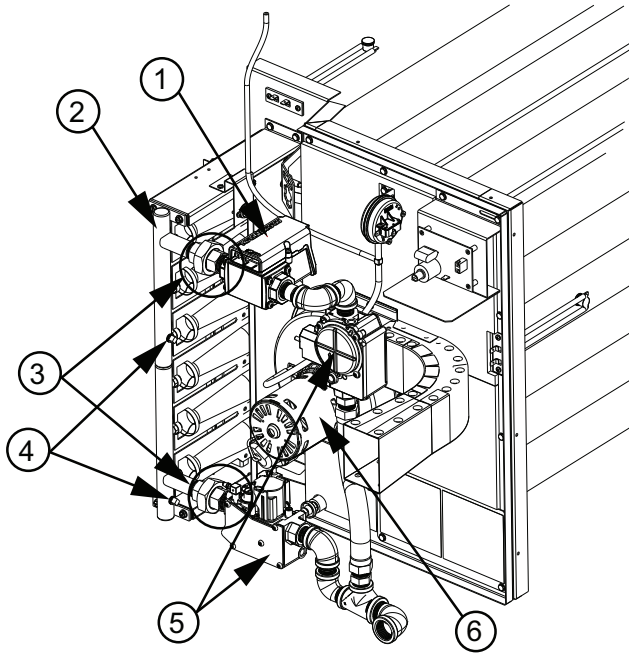

**Table 2. Parts list**

Item	Component
1	Modulating gas valve
2	Gas manifold and gas orifices
3	Disconnect these pipe unions to remove the gas valve assembly.
4	Manifold pressure tap plugs
5	Regulating gas valves (2)
6	Inducer fan

**Figure 2. Location of gas heat components and connections – D cabinet**

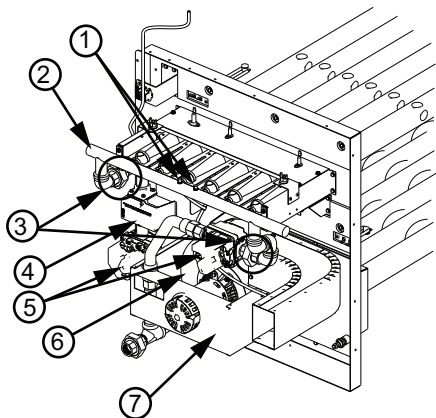

**Table 3. Parts list**

Item	Component
1	Manifold pressure tap plugs
2	Gas manifold and gas orifices
3	Disconnect these pipe unions to remove the gas valve assembly.
4	Modulating gas valve
5	Regulating gas valves (2)
6	Inducer fan
7	Inducer fan support bracket

1. Shut-off all gas supply to the unit using the manual shut-off valve before proceeding with the conversion.
2. Disconnect or shut off all electrical power to the module and turn thermostat to lowest temperature setting.

See [Figure 1, p. 5](#) and [Figure 2, p. 5](#) for locations of components and connections.

## Manifold and Gas Train

1. Remove the access panels for the heating compartment and the control box.

### **⚠ WARNING**

#### **Hazardous Voltage and Gas!**

**Failure to turn off gas or disconnect power before servicing could result in an explosion or electrocution which could result in death or serious injury.**

**Turn off the gas supply and disconnect all electric power, including remote disconnects, before servicing the unit. Follow proper lockout/tagout procedures to ensure the power can not be inadvertently energized.**

2. Shut-off all gas supply to the unit using the manual shut-off valve before proceeding with the conversion.
3. Disconnect or shut-off all electrical power to the module and turn thermostat to lowest temperature setting.
4. If an inducer fan support bracket is present, remove the nuts securing it and remove the bracket.
5. Loosen the two gas pipe unions at the manifold pipe. Unions locations are as follows:
  - Between the manifold assembly and a regulating gas valve.
  - Between the manifold assembly and the modulating gas valve.
6. Separate the modulating gas valve and regulating gas valves assembly from the gas manifold assembly.

## Installation

7. Remove four screws securing the manifold pipe assembly to the burner assembly.
8. Remove the natural gas orifices from manifold.
9. Install all propane gas orifices provided with the LP kit.
10. Open the gas valve spring conversion kits and follow the instructions provided.
11. Convert the two regulating gas valves to LP operation.
12. Using the four screws removed in [Step 7.](#), secure the manifold assembly to the burner assembly. Confirm orifices align with the opening on each burner.
13. Tighten the two gas pipe unions and secure the modulating gas valve and regulating gas valves assembly to the gas manifold.
14. Remove the blue cover from the EXA E55 modulating gas valve. In the group of five DIP switches, change switch number DS1-2 from **OFF** to **ON**.

**Figure 3. Modulating gas valve**

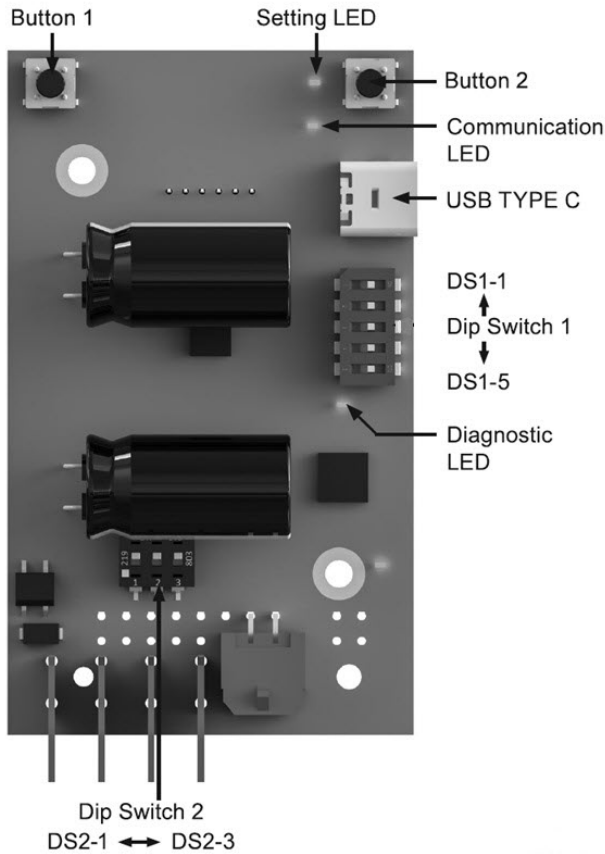

15. Replace the blue cover on the modulating gas valve.
16. Apply the labels provided in spring kits to the gas valves to indicate the furnace has been converted to LP operation.
17. Attach the LP conversion label to the inside of the gas heat access panel.

18. Open the manual shut-off gas valves and use a soap solution to leak-check gas piping to the gas valve.

**Figure 4. Inducer, gasket, and orifice plate assembly – B and C cabinet**

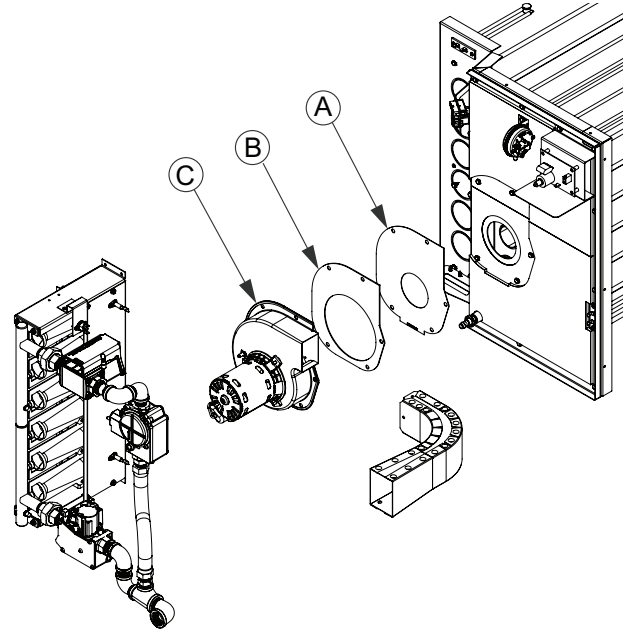

**Table 4. Parts list – B and C cabinet**

Item	Component
A	Inducer orifice plate
B	Gasket
C	Draft fan

**Figure 5. Inducer, gasket, and orifice plate assembly – D cabinet**

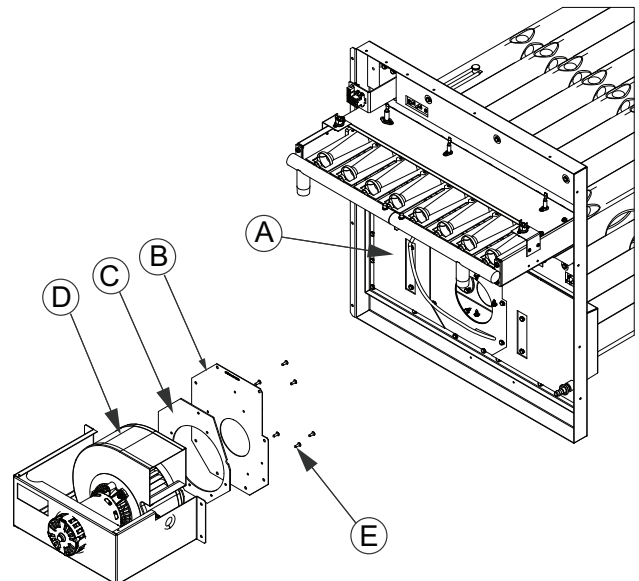

**Table 5. Parts list – D cabinet**

Item	Component
A	Face plate insulation/gasket
B	Inducer orifice plate
C	Fan to orifice gasket
D	Draft fan
E	Qty 7 steel 5/32 rivet 0.188 to 0.250 grip range

## Inducer Orifice Plate

- Unplug the inducer fan wiring (black, white, and brown wires) from the heating unit harness. Remove the inducer pressure tubing from the inducer.  
**Note:** *The brown wire will not be present on 80 and 120 MBh inputs.*
- If an inducer fan support bracket is present, remove the nuts securing it and remove the bracket.
- Remove the nuts holding the inducer fan assembly to the heater flue collector box. Note the placement of the inducer gasket as the assembly is removed. See [Figure 4, p. 6](#) and [Figure 5, p. 6](#).
- If the inducer orifice plate is secured to the inducer fan housing using rivets, follow [Step 5.](#) to [Step 7.](#) below. If no rivets are present, proceed to [Step 8.](#)
- Using a 0.156-inch bit, drill out the rivets to remove the inducer orifice plate from the inducer fan housing.
- Position the LP kit inducer orifice plate in the same orientation as the previous orifice plate.
- Using rivets provided in the kit, secure the LP kit inducer orifice plate onto the inducer fan housing. Proceed to [Step 10.](#)
- Separate the inducer orifice plate from the inducer fan housing.
- Position the LP kit inducer orifice plate in the same orientation as the previous orifice plate.
- Install inducer fan to the heater flue collector box. Use the inducer gasket included in the kit.
- Confirm the flue screen is in place at end of the flue pipe.
- If an inducer fan support bracket was removed in [Step 2.](#), reinstall the bracket.
- Plug the inducer fan wires into to heating unit harness. Reconnect the inducer pressure tubing to the inducer.

## ID Chip

- Remove the natural gas ID chip from the VB1285 heater control. Using a precision tip flat heat screwdriver, deflect the holding clip back from the ID chip and pull the ID chip up and away from the control board.

**Note:** *The control is located inside the unit control box. The location of the ID chip on the board is shown in [Figure 6, p. 8.](#)*

- Install the provided propane gas ID chip on the VB1285 heater control.

## LP Modulating System with VB1285

- Remove plugs from manifold pressure taps and connect manometers or pressure gauges capable of measuring at least 10-inch w.c. to tapping (see [Figure 1, p. 5](#) and [Figure 2, p. 5](#)).
- With the DIP switch change on the modulating valve ([Step 14.](#)), the modulating valve will utilize the propane operating parameters that are already programmed within the valve. No other adjustments are necessary.
- Turn on power to unit.
- Verify proper LED callout from VB1285 control board.
  - First flash is the model of unit (H-P, H-Q, H-R).
  - Next flash is MBh input (080, 120, 150, 200, 240, 250, or 400).
  - Next flash is turndown (-10).
  - With change to propane, next flash is (-LP).
  - All callouts should match the rating sticker located on the heater fan support bracket.
- Initiate a call for heat – Provide a Modbus® signal of 100 percent.
- Draft fan will start at high speed and run for a 30 second pre-purge period.
- At the end of pre-purge period, an ignition cycle is initiated opening the regulating gas valve. It starts a 10 second sequence through VB1285 control to establish a warm-up period. No adjustments can be made during the warm-up period.
- At the end of the warm-up period, with Modbus signal at 100 percent, the draft fan will stay at high speed.
- Adjust maximum input manifold pressure to 9.5-in. to 10-in. w.c. at both manifold pressure taps on the gas manifold pipe. Remove the screw cap(s) for access, turn the adjustment screw on the regulating gas valve (s) clockwise to increase manifold pressure or counterclockwise to decrease pressure.
- Decrease the Modbus signal to 0.5 percent. Verify minimum input manifold pressure to 0.9-inch to 1.2-inch w.c. Contact manufacturer if manifold pressure is not correct.
- Remove Modbus signal to the heating unit.
- Reinstall screw cap(s) on the regulating gas valves.
- Shut-off power to system.
- Remove pressure gauges from the manifold taps and replace pipe plugs.

## Installation

---

15. Turn gas and power **ON** and reset thermostat or controller.

16. Replace the access panels.

The unit is now ready to operate from building or zone controller.

**Figure 6. Control board with ID chip and ID plug**

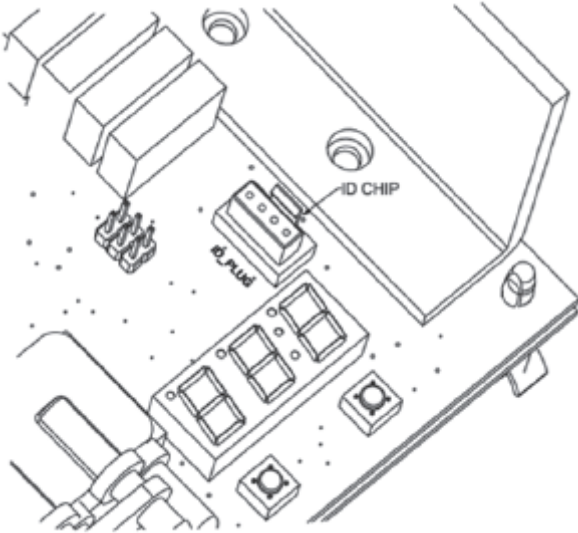







Trane and American Standard create comfortable, energy efficient indoor environments for commercial and residential applications. For more information, please visit [trane.com](http://trane.com) or [americanstandardair.com](http://americanstandardair.com).

Trane and American Standard have a policy of continuous product and product data improvement and reserve the right to change design and specifications without notice. We are committed to using environmentally conscious print practices.

ACC-SVN269E-EN 30 Mar 2026  
Supersedes ACC-SVN269D-EN (September 2025)

©2026