

Installation Instructions

Roof Curb

Precedent™ Packaged Rooftop Units 10 to 12.5 Tons

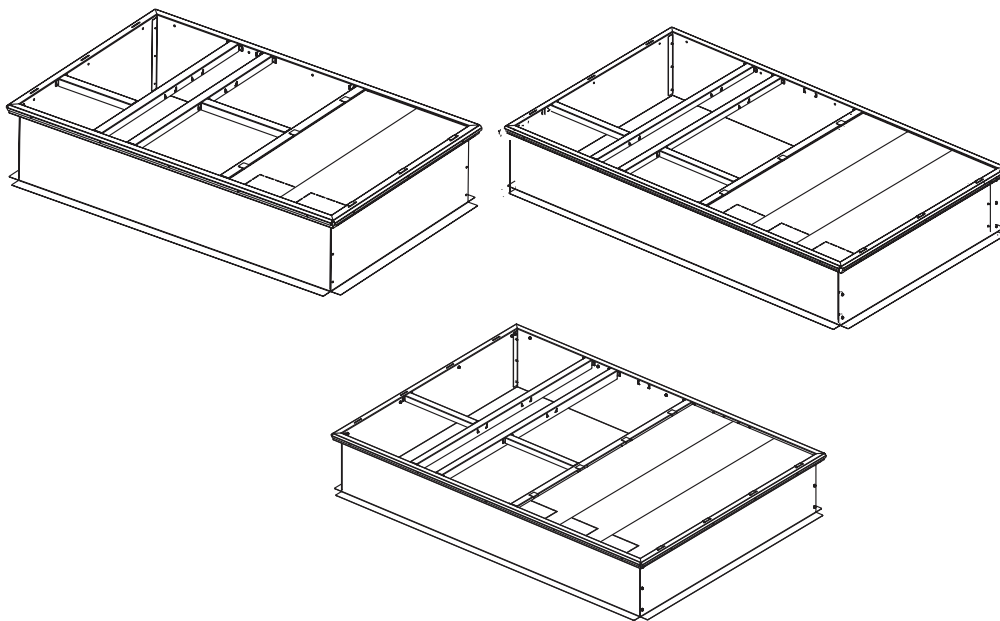

Model Number:

FIACURB403*

FIACURB803*

Used With:

Precedent C cabinet (Digit 39 = C) with 14-inch curb

Precedent C cabinet (Digit 39 = C) with 18-inch curb

SAFETY WARNING

Only qualified personnel should install and service the equipment. The installation, starting up, and servicing of heating, ventilating, and air-conditioning equipment can be hazardous and requires specific knowledge and training. Improperly installed, adjusted or altered equipment by an unqualified person could result in death or serious injury. When working on the equipment, observe all precautions in the literature and on the tags, stickers, and labels that are attached to the equipment.

Introduction

Read this manual thoroughly before operating or servicing this unit.

Warnings, Cautions, and Notices

Safety advisories appear throughout this manual as required. Your personal safety and the proper operation of this machine depend upon the strict observance of these precautions.

The three types of advisories are defined as follows:

- ⚠ WARNING** Indicates a potentially hazardous situation which, if not avoided, could result in death or serious injury.
- ⚠ CAUTION** Indicates a potentially hazardous situation which, if not avoided, could result in minor or moderate injury. It could also be used to alert against unsafe practices.
- NOTICE** Indicates a situation that could result in equipment or property-damage only accidents.

Important Environmental Concerns

Scientific research has shown that certain man-made chemicals can affect the earth's naturally occurring stratospheric ozone layer when released to the atmosphere. In particular, several of the identified chemicals that may affect the ozone layer are refrigerants that contain Chlorine, Fluorine and Carbon (CFCs) and those containing Hydrogen, Chlorine, Fluorine and Carbon (HCFCs). Not all refrigerants containing these compounds have the same potential impact to the environment. Trane advocates the responsible handling of all refrigerants.

Important Responsible Refrigerant Practices

Trane believes that responsible refrigerant practices are important to the environment, our customers, and the air conditioning industry. All technicians who handle refrigerants must be certified according to local rules. For the USA, the Federal Clean Air Act (Section 608) sets forth the requirements for handling, reclaiming, recovering and recycling of certain refrigerants and the equipment that is used in these service procedures. In addition, some states or municipalities may have additional requirements that must also be adhered to for responsible management of refrigerants. Know the applicable laws and follow them.

⚠ WARNING

Proper Field Wiring and Grounding Required!

Failure to follow code could result in death or serious injury. All field wiring **MUST** be performed by qualified personnel. Improperly installed and grounded field wiring poses **FIRE** and **ELECTROCUTION** hazards. To avoid these hazards, you **MUST** follow requirements for field wiring installation and grounding as described in **NEC** and your local/state/national electrical codes.

⚠ WARNING

Personal Protective Equipment (PPE) Required!

Failure to wear proper PPE for the job being undertaken could result in death or serious injury. Technicians, in order to protect themselves from potential electrical, mechanical, and chemical hazards, **MUST** follow precautions in this manual and on the tags, stickers, and labels, as well as the instructions below:

- Before installing/servicing this unit, technicians **MUST** put on all PPE required for the work being undertaken (Examples; cut resistant gloves/sleeves, butyl gloves, safety glasses, hard hat/bump cap, fall protection, electrical PPE and arc flash clothing). **ALWAYS** refer to appropriate Safety Data Sheets (SDS) and OSHA guidelines for proper PPE.
- When working with or around hazardous chemicals, **ALWAYS** refer to the appropriate SDS and OSHA/GHS (Global Harmonized System of Classification and Labeling of Chemicals) guidelines for information on allowable personal exposure levels, proper respiratory protection and handling instructions.
- If there is a risk of energized electrical contact, arc, or flash, technicians **MUST** put on all PPE in accordance with OSHA, NFPA 70E, or other country-specific requirements for arc flash protection, **PRIOR** to servicing the unit. **NEVER PERFORM ANY SWITCHING, DISCONNECTING, OR VOLTAGE TESTING WITHOUT PROPER ELECTRICAL PPE AND ARC FLASH CLOTHING. ENSURE ELECTRICAL METERS AND EQUIPMENT ARE PROPERLY RATED FOR INTENDED VOLTAGE.**

⚠ WARNING

Follow EHS Policies!

Failure to follow instructions below could result in death or serious injury.

- All Trane personnel must follow the company's Environmental, Health and Safety (EHS) policies when performing work such as hot work, electrical, fall protection, lockout/tagout, refrigerant handling, etc. Where local regulations are more stringent than these policies, those regulations supersede these policies.
- Non-Trane personnel should always follow local regulations.

⚠ WARNING

R-454B Flammable A2L Refrigerant!

Failure to use proper equipment or components as described below could result in equipment failure, and possibly fire, which could result in death, serious injury, or equipment damage.

The equipment described in this manual uses R-454B refrigerant which is flammable (A2L). Use ONLY R-454B rated service equipment and components. For specific handling concerns with R-454B, contact your local representative.

Copyright

This document and the information in it are the property of Trane, and may not be used or reproduced in whole or in part without written permission. Trane reserves the right to revise this publication at any time, and to make changes to its content without obligation to notify any person of such revision or change.

Trademarks

All trademarks referenced in this document are the trademarks of their respective owners.

Revision History

- Added tonnage information on Front cover page.
- Updated Installation chapter.
- Updated Weights and Center of Gravity chapter.

General Information

Carefully review installation instructions.

- This manual describes the layout and installation procedures required to properly assemble and install the roof curb.
- Each curb package ships unassembled, along with the required hardware and gasketing material.
- Roof insulation, cant strips, flashing (if desired), nails, and sheet metal screws must be furnished by the installing contractor.

Important: *DO NOT discard EPS foam panels included in this kit. They are used for insulating the condenser section of the roof curb. Follow instructions for installation.*

Inspection

1. Unpack all components of the kit.
2. Check carefully for shipping damage. If any damage is found, report it immediately, and file a claim against the transportation company.

Clearances

The recommended clearances for single-unit installations (minimum requirements) are not only an important consideration when determining unit placement, but they are also essential to ensure adequate serviceability, maximum capacity, and peak operation efficiency.

Any reduction of the unit clearances indicated in these illustrations may result in condenser coil starvation, or the recirculation of warm condenser air. Actual clearances which appear to be inadequate should be reviewed with a local sales engineer.

Installation

- Carefully review installation instructions.
- If the curb will be mounted on a new building, assemble the curb before roof support members are in place.
- Place the curb directly on the roof support members.
- Use tack welding or other suitable fastening method to secure the roof curb in place.

Notes:

- If the curb will be mounted on a roof deck, additional nailing plates must be provided directly below the flanges of the curb for additional support, and to minimize vibration.
- When the installation is on an existing building, hoist the shipping container directly onto the roof.

Supply and Return Air Ductwork

Before setting the unit in place, run ductwork and attach to the curb.

All ductwork must be fabricated and installed by the installing contractor. To verify proper duct construction and installation, SMACNA recommendations should be closely followed.

Note: All field fabricated panels used must be insulated. See [Step 10](#).

Roof Opening

For safety and sound considerations, do not cut out the entire roof deck within the curb area.

Roof Support

⚠ WARNING

Heavy Objects!

Failure to follow instructions below could result in unit dropping which could result in death or serious injury, and equipment or property-only damage. Ensure that all the lifting equipment used is properly rated for the weight of the unit being lifted. Each of the cables (chains or slings), hooks, and shackles used to lift the unit must be capable of supporting the entire weight of the unit. Lifting cables (chains or slings) may not be of the same length. Adjust as necessary for even unit lift.

Important: Refer to weight tables for specific weights within this piece.

- Units may be set either lateral or parallel to the roof support members.
- The combined weight of the unit, accessories, and curb should be evenly spaced between a minimum of two supports.

- Verify the curb position on the roof supports does not interfere with the clearance required for the supply/return ductwork. See [Figure 2](#).

Note: It is recommended that the starting collars for the supply and return duct work be installed before the curb is placed into position.

Roof Curb Installation

Parts List

Table 1. Parts list

Qty	Description
2	Ends
2	Sides
3	Long Duct Supports
2	Short Duct Supports
4	Insulation Supports
3	EPS Foam Insulation Sheets
–	Gasket

There are more attachment locations (raised triangular shaped corner slots) than actual component attachments. To assemble the roof curb, use a tape measure to verify components are in the correct orientation. Use the dimensions from the diagram to locate the correct attachment slots for the internal supports.

- Set the two sides and two ends on a flat surface to form a square, with the wood nailers facing the outside. See the following figure.

Note: Assembling a long duct support will hold the sides in place while fastening ends.

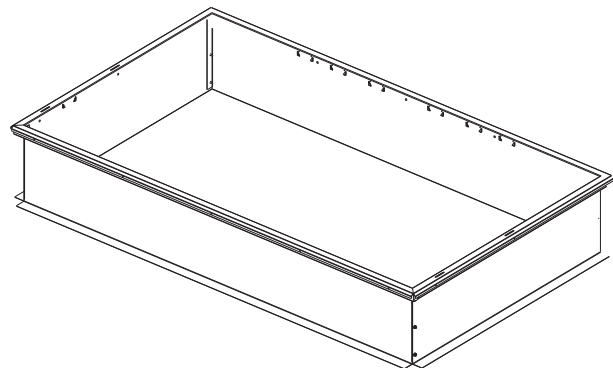

- Join the sides and ends together with the 1/4 x 5/8 screws provided.
- Assemble a long (56.42 inches) duct support between the two sides (return section).

Installation

4. Insert the first duct support 18.46 inches from either end by inserting the tabs on each end of the duct support into the appropriate triangular shaped slots. See the following figure.
5. Insert the other two long duct supports as shown on the top view (supply section). See the following figure. Verify the 5.10-inch and 18.45-inch dimensions between long duct supports.

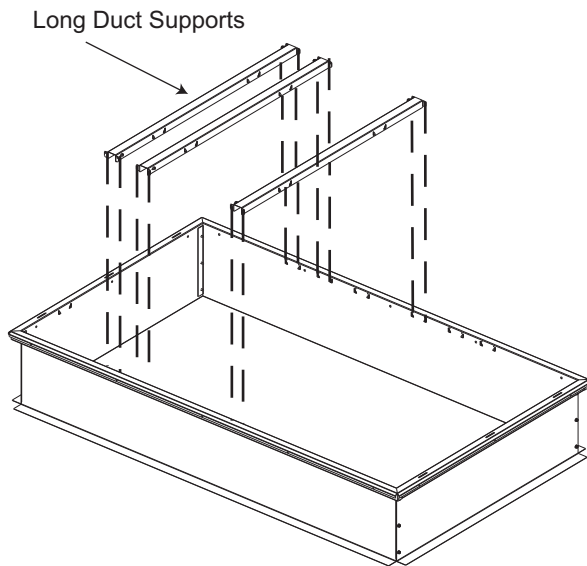

6. At 20.25 inches from the side, locate the position for the short duct support that fits between the first long duct support and the end.
7. Insert the support flanges into the appropriate corner catches. Verify the 20.25-inch dimension. See the following figure.
8. Insert the second short duct support between the middle and right long duct supports. Verify the 20.25-inch dimension from the duct support to the side (in line with previously assembled short duct support). See the following figure.

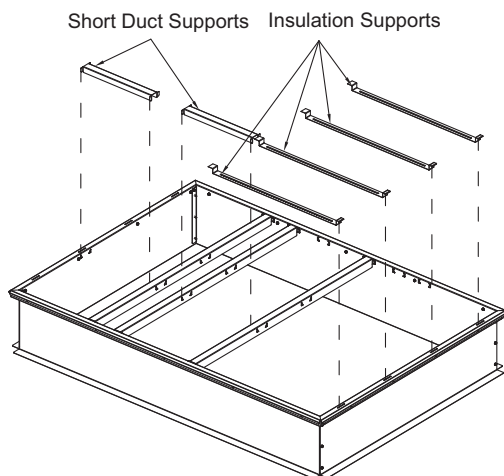

9. Insert the four insulation supports between the right end and the closest long duct support and insert the tabs into the slots in the top of the end piece. See the following figure.

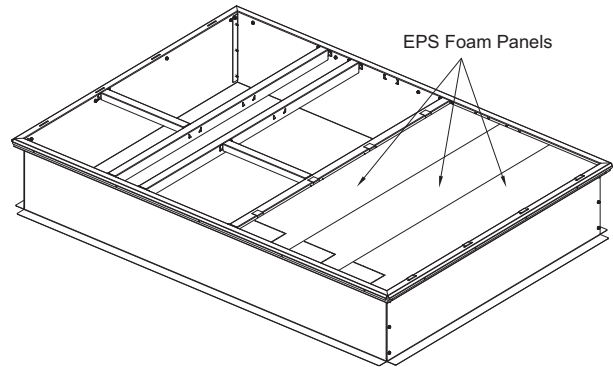

10. Install three pieces of foam insulation and gasket. See the following figure.

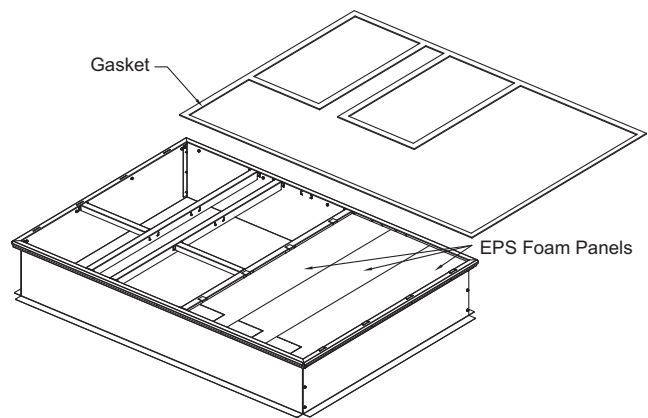

Installation

Figure 1. Curb dimensional data

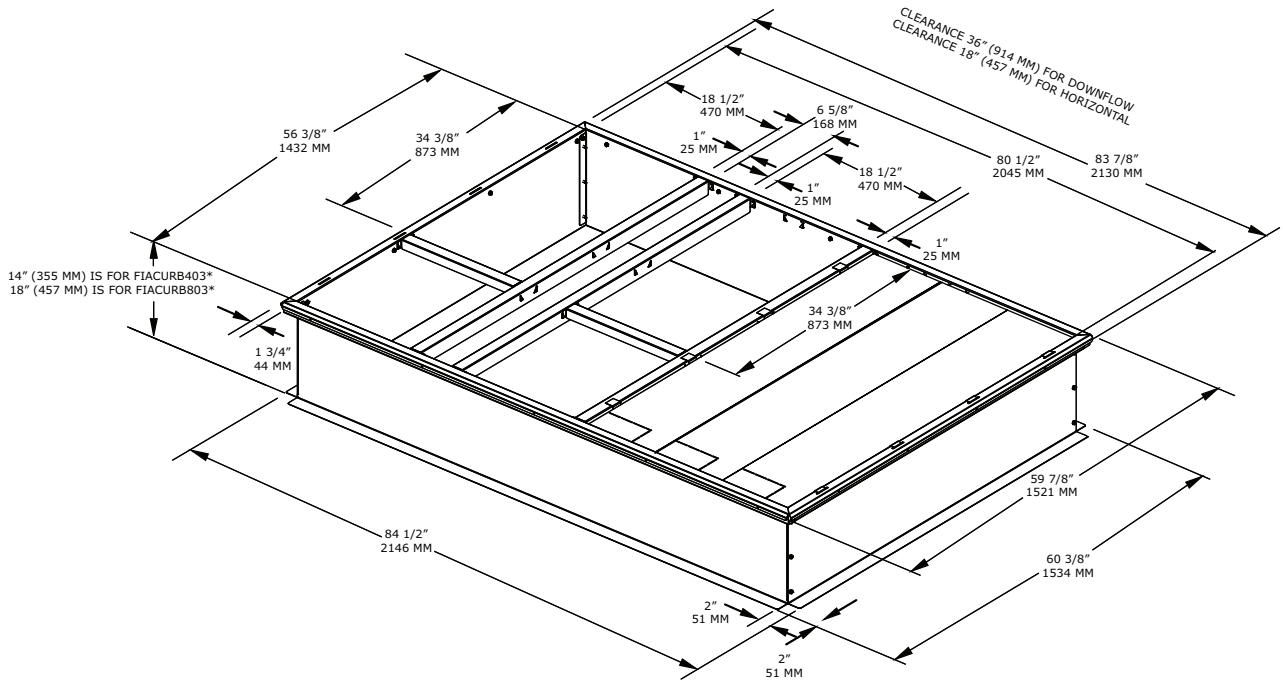

Note: Curb plenum drops/duct inserts are designed and tested to hold 250 lbs. Verify duct drops are supported per local building codes.

Figure 2. Curb dimensional data

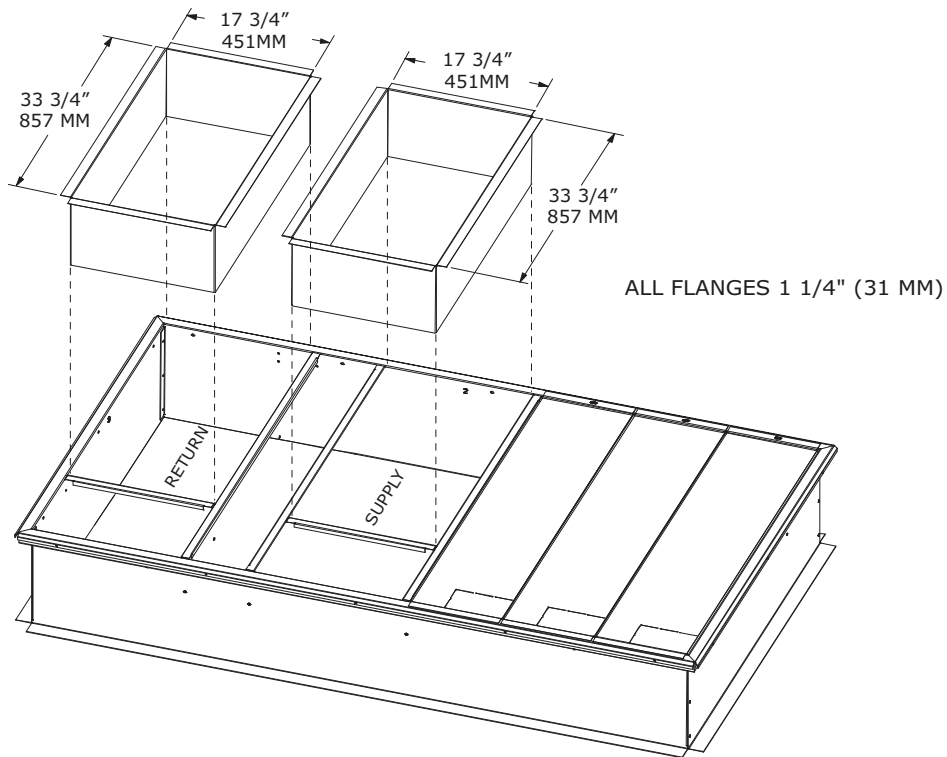

Installation

Figure 3. Roof construction

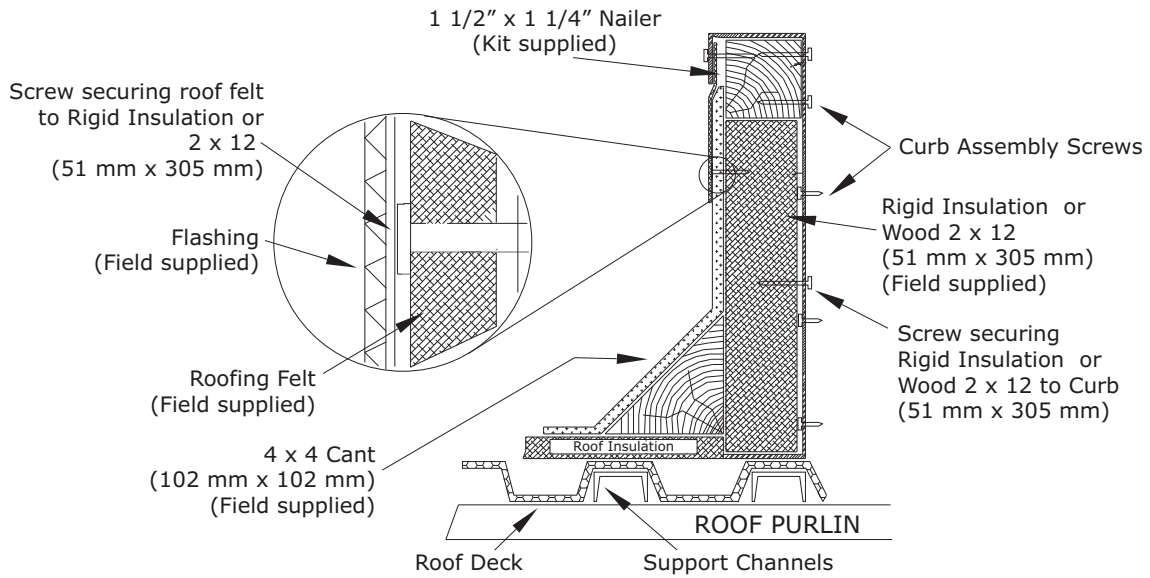
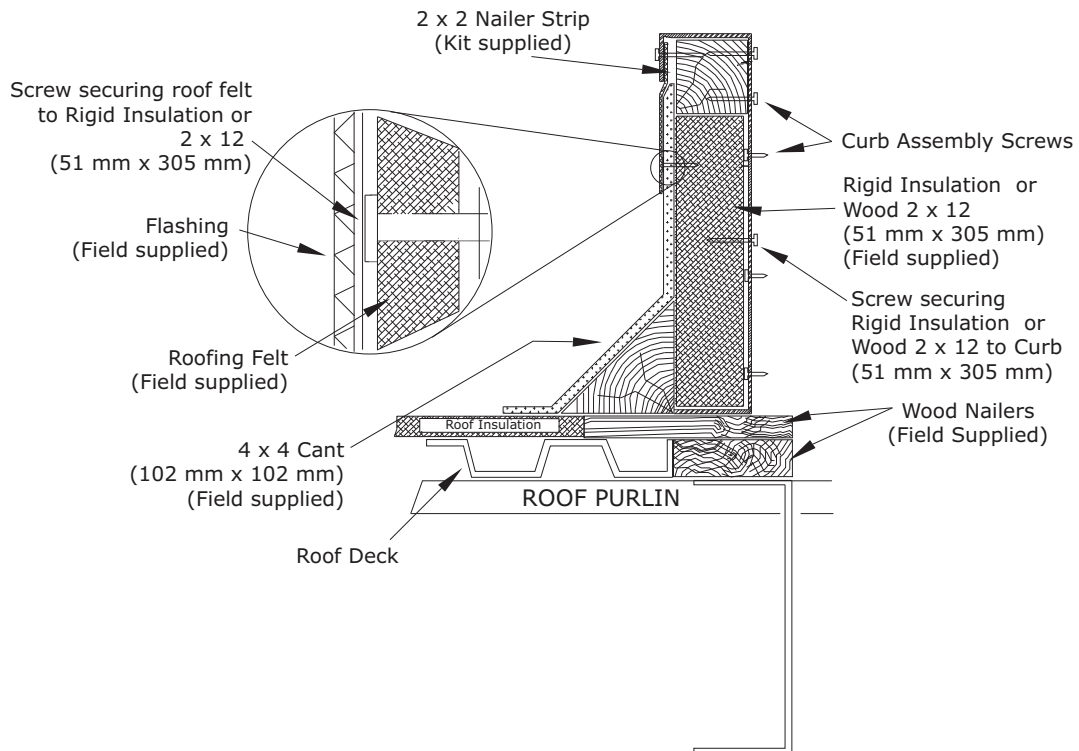

Figure 4. Existing roof construction



Weights and Center of Gravity

Table 2. Model weights, corner weights (lbs) and center of gravity dimensions (in.) - cooling models

Tons	Unit Model No.	Model Weights ^(a)		Corner Weights ^(b)				Center of Gravity (in.)	
		Shipping	Net	A	B	C	D	Length	Width
Standard Efficiency									
12.5	TS*150	1412	1218	464	343	175	236	43	21
Ultra High Efficiency									
10	TZ*120	1372	1178	345	347	244	243	50	26

(a) Weights are approximate. Weights do not include additional factory or field installed options/accessories. For option/accessory additional weights to be added to unit weight, refer to [Table 6](#).

(b) Corner weights are given for information only.

Table 3. Model weights, corner weights (lbs) and center of gravity dimensions (in.) - gas/electric models

Tons	Unit Model No.	Model Weights ^(a)		Corner Weights ^(b)				Center of Gravity (in.)	
		Shipping	Net	A	B	C	D	Length	Width
Standard Efficiency									
12.5	YS*150	1412	1218	464	343	175	236	43	21
Ultra High Efficiency									
10	YZ*150	1439	1245	377	371	246	250	50	25

(a) Weights are approximate. Weights do not include additional factory or field installed options/accessories. For option/accessory additional weights to be added to unit weight, refer to [Table 6](#).

(b) Corner weights are given for information only.

Table 4. Model weights, corner weights (lbs) and center of gravity dimensions (in.) - heat pump/electric

Tons	Unit Model No.	Model Weights ^(a)		Corner Weights ^(b)				Center of Gravity (in.)	
		Shipping	Net	A	B	C	D	Length	Width
Standard Efficiency									
10	WS*120	1433	1239	363	380	249	247	48	30
High Efficiency									
10	WH*150	1433	1239	363	380	249	247	48	30

(a) Weights are approximate. Weights do not include additional factory or field installed options/accessories. For option/accessory additional weights to be added to unit weight, refer to [Table 6](#).

(b) Corner weights are given for information only.

Table 5. Model weights, corner weights (lbs) and center of gravity dimensions (in.) - heat pump/gas – dual fuel

Tons	Unit Model No.	Model Weights ^(a)		Corner Weights ^(b)				Center of Gravity (in.)	
		Shipping	Net	A	B	C	D	Length	Width
Standard Efficiency									
10	DS*120	1500	1306	356	328	299	323	48	30
High Efficiency									
10	DH*120	1500	1306	356	328	299	323	48	30

(a) Weights are approximate. Weights do not include additional factory or field installed options/accessories. For option/accessory additional weights to be added to unit weight, refer to [Table 6](#).

(b) Corner weights are given for information only.

Weights and Center of Gravity

Figure 5. Center of gravity

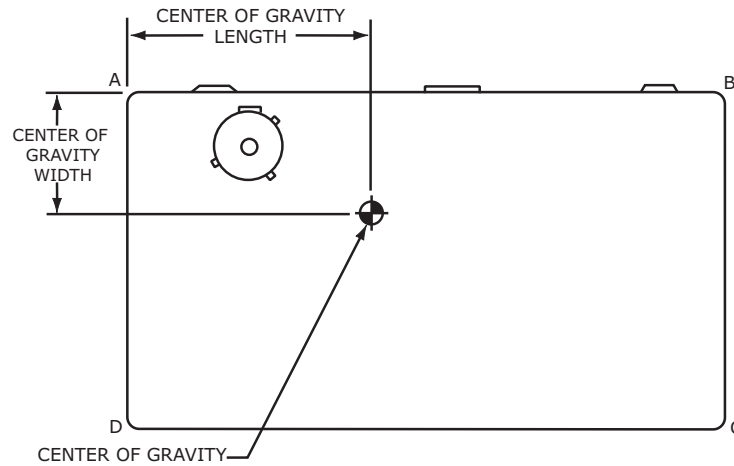

Figure 6. Center of gravity

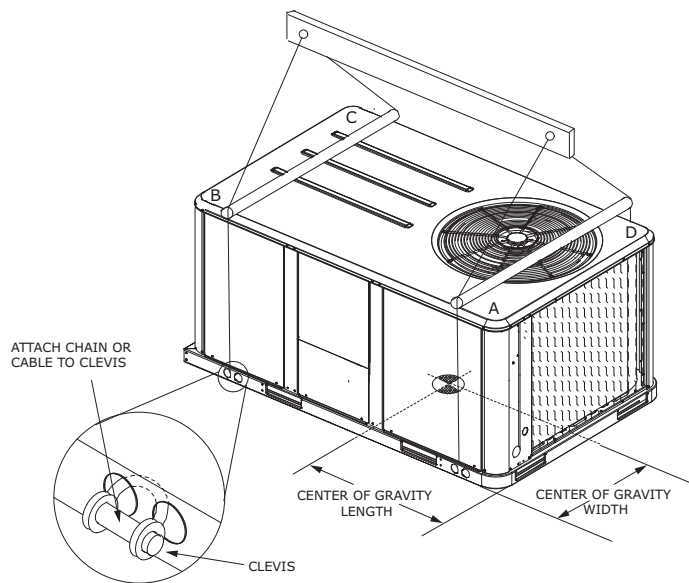

Table 6. Factory installed options (fiops)/accessory net weights (lbs)

Accessory	10 to 12.5 Tons
Barometric Relief	10
Economizer	36
Electric Heaters ^(a)	50
Hinged Doors	12
Low Leak Economizer - Downflow	91
Low Leak Economizer - Horizontal	186
Manual Outside Air Damper	26
Motorized Outside Air Damper	30
Oversized Motor ^(b)	14
Powered Convenience Outlet	50
Powered Exhaust	80
Reheat Coil	20

Table 6. Factory installed options (fiops)/accessory net weights (lbs) (continued)

Accessory	10 to 12.5 Tons
Roof Curb	111
Smoke Detector, Supply ^(b)	5
Smoke Detector, Return	7
Stainless Steel Heat Exchanger ^(c)	6
Through-the-Base Electrical	13
Through-the-Base Gas ^(c)	5
Unit Mounted Circuit Breaker	5
Unit Mounted Disconnect	5

Notes:

1. Weights for options not listed are less than 5 pounds.
2. Net weight should be added to unit weight when ordering factory-installed accessories.
3. Weights are approximate.

(a) Only applies to T/W*K models.

(b) Not available on all models.

(c) Only applies to Y/D*K models.

Trane and American Standard create comfortable, energy efficient indoor environments for commercial and residential applications. For more information, please visit trane.com or americanstandardair.com.

Trane and American Standard have a policy of continuous product and product data improvement and reserve the right to change design and specifications without notice. We are committed to using environmentally conscious print practices.