

Installation Guide

Symbio™ 700 Customer Connection Module

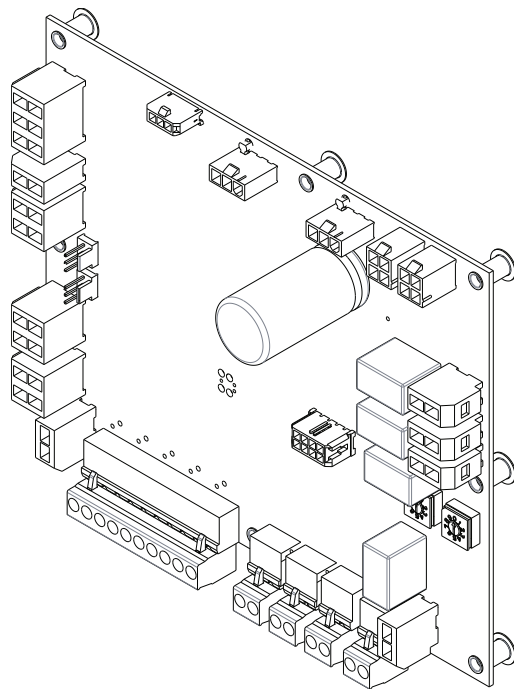

Model Number: FIASCCM001* **Used With:** Precedent™ and Voyager™ 3 with Symbio™ 700 Controls

⚠ SAFETY WARNING

Only qualified personnel should install and service the equipment. The installation, starting up, and servicing of heating, ventilating, and air-conditioning equipment can be hazardous and requires specific knowledge and training. Improperly installed, adjusted or altered equipment by an unqualified person could result in death or serious injury. When working on the equipment, observe all precautions in the literature and on the tags, stickers, and labels that are attached to the equipment.

Introduction

Read this manual thoroughly before operating or servicing this unit.

Warnings, Cautions, and Notices

Safety advisories appear throughout this manual as required. Your personal safety and the proper operation of this machine depend upon the strict observance of these precautions.

The three types of advisories are defined as follows:



Indicates a potentially hazardous situation which, if not avoided, could result in death or serious injury.



Indicates a potentially hazardous situation which, if not avoided, could result in minor or moderate injury. It could also be used to alert against unsafe practices.

NOTICE

Indicates a situation that could result in equipment or property-damage only accidents.

Important Environmental Concerns

Scientific research has shown that certain man-made chemicals can affect the earth's naturally occurring stratospheric ozone layer when released to the atmosphere. In particular, several of the identified chemicals that may affect the ozone layer are refrigerants that contain Chlorine, Fluorine and Carbon (CFCs) and those containing Hydrogen, Chlorine, Fluorine and Carbon (HCFCs). Not all refrigerants containing these compounds have the same potential impact to the environment. Trane advocates the responsible handling of all refrigerants-including industry replacements for CFCs and HCFCs such as saturated or unsaturated HFCs and HCFCs.

Important Responsible Refrigerant Practices

Trane believes that responsible refrigerant practices are important to the environment, our customers, and the air conditioning industry. All technicians who handle refrigerants must be certified according to local rules. For the USA, the Federal Clean Air Act (Section 608) sets forth the requirements for handling, reclaiming, recovering and recycling of certain refrigerants and the equipment that is used in these service procedures. In addition, some states or municipalities may have additional requirements that must also be adhered to for responsible management of refrigerants. Know the applicable laws and follow them.

⚠ WARNING

Proper Field Wiring and Grounding Required!

Failure to follow code could result in death or serious injury.

All field wiring **MUST** be performed by qualified personnel. Improperly installed and grounded field wiring poses **FIRE** and **ELECTROCUTION** hazards. To avoid these hazards, you **MUST** follow requirements for field wiring installation and grounding as described in **NEC** and your local/state/national electrical codes.

⚠ WARNING

Personal Protective Equipment (PPE) Required!

Failure to wear proper PPE for the job being undertaken could result in death or serious injury.

Technicians, in order to protect themselves from potential electrical, mechanical, and chemical hazards, **MUST** follow precautions in this manual and on the tags, stickers, and labels, as well as the instructions below:

- **Before installing/servicing this unit, technicians MUST put on all PPE required for the work being undertaken (Examples; cut resistant gloves/sleeves, butyl gloves, safety glasses, hard hat/bump cap, fall protection, electrical PPE and arc flash clothing). ALWAYS refer to appropriate Safety Data Sheets (SDS) and OSHA guidelines for proper PPE.**
- **When working with or around hazardous chemicals, ALWAYS refer to the appropriate SDS and OSHA/GHS (Global Harmonized System of Classification and Labelling of Chemicals) guidelines for information on allowable personal exposure levels, proper respiratory protection and handling instructions.**
- **If there is a risk of energized electrical contact, arc, or flash, technicians MUST put on all PPE in accordance with OSHA, NFPA 70E, or other country-specific requirements for arc flash protection, PRIOR to servicing the unit. NEVER PERFORM ANY SWITCHING, DISCONNECTING, OR VOLTAGE TESTING WITHOUT PROPER ELECTRICAL PPE AND ARC FLASH CLOTHING. ENSURE ELECTRICAL METERS AND EQUIPMENT ARE PROPERLY RATED FOR INTENDED VOLTAGE.**

⚠ WARNING

Follow EHS Policies!

Failure to follow instructions below could result in death or serious injury.

- All Trane personnel must follow the company's Environmental, Health and Safety (EHS) policies when performing work such as hot work, electrical, fall protection, lockout/tagout, refrigerant handling, etc. Where local regulations are more stringent than these policies, those regulations supersede these policies.
- Non-Trane personnel should always follow local regulations.

Copyright

This document and the information in it are the property of Trane, and may not be used or reproduced in whole or in part without written permission. Trane reserves the right to revise this publication at any time, and to make changes to its content without obligation to notify any person of such revision or change.

Trademarks

All trademarks referenced in this document are the trademarks of their respective owners.

Revision History

Added reference to Customer Connection Module in figure 3.

General Information

This kit is only used with ventilation override (Precedent™ only), remote minimum position, external auto/stop features, humidstat, and alarm indicator.

Inspection

1. Unpack all components of the kit.
2. Check carefully for shipping damage. If any damage is found, report it immediately, and file a claim against the transportation company.
3. Visually inspect the components for shipping damage as soon as possible after delivery, before it is stored. Concealed damage must be reported within 15 days.

4. If concealed damage is discovered, stop unpacking the shipment.
5. Do not remove damaged material from the receiving location. Take photos of the damage, if possible. The owner must provide reasonable evidence that the damage did not occur after delivery.
6. Notify the carrier's terminal of damage immediately by phone and by mail. Request an immediate joint inspection of the damage by the carrier and the consignee.

Note: Do not attempt to repair any damaged parts until the parts are inspected by the carrier's representative.

Table 1. Specifications

Operating Temperature Range	-40 to 70°C (24 Vac)	
LEDs	Color	Description
	Green	Status
	Red	Status
	Green	TX
	Yellow	RX
Agency	UL/CSA 60730 listed UL94-5V Flammability FCC Part 15, Class B Emissions	

Parts List

Figure 1. Kit contents

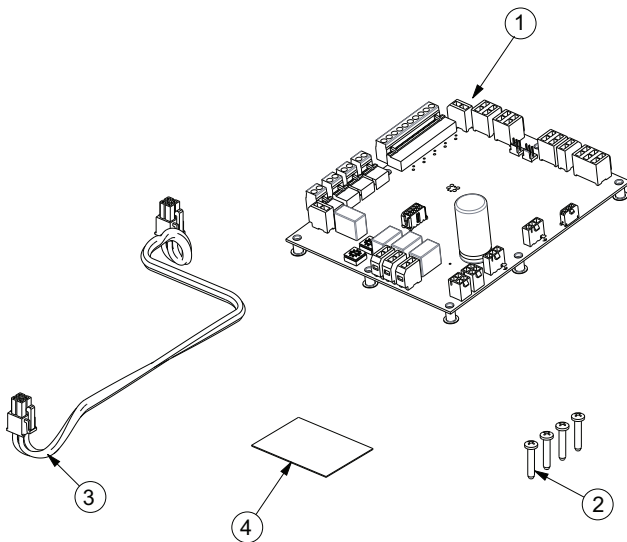

Table 2. Parts list

Item	Description	Quantity
1	Customer Connection module	1
2	Screws	4
3	Harness IMC communication (product dependent)	2
4	Information label	1

Installation

⚠ WARNING

Hazardous Voltage!

Failure to disconnect power before servicing could result in death or serious injury.

Disconnect all electric power, including remote disconnects before servicing. Follow proper lockout/tagout procedures to ensure the power can not be inadvertently energized. Verify that no power is present with a voltmeter.

1. Confirm power to the unit has been disconnected and locked out.
2. For Precedent™ units, open the access panel to gain access to the right side of the main unit control box. For Voyager™ 3 units, access is on the left side of the main control unit.
3. Install the Customer Connection module and secure the board with four screws (provided in kit) (see [Figure 2, p. 5](#) or [Figure 3, p. 5](#)). Ensure P5 connector is orientated to the top right position.

Figure 2. Precedent™ - customer connection module



Figure 3. Voyager™ 3 - customer connection module

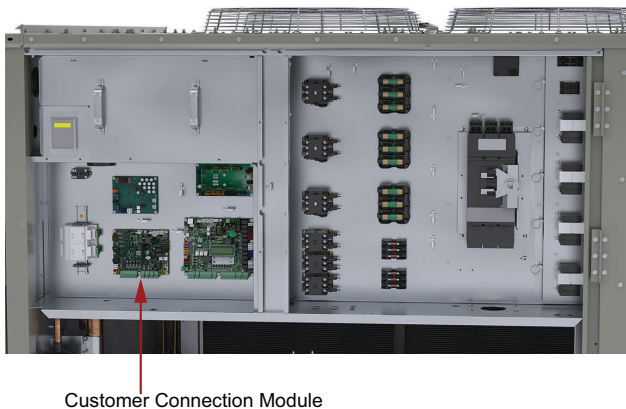

4. On the Customer Connection module, set the address rotary switches to 78. This is required to integrate the Customer Connection module with the Symbio™ controller. After installation is complete, the Symbio™ 700 UC configuration will need to be updated to enable this installed feature.

UC configuration needs to be updated to enable this installed feature using Symbio™ Service and Installation Mobile application or Symbio™ 700 User Interface.

5. This kit includes harnesses for Precedent™ and Voyager™ 3:
 - For Precedent™, connect one of the harnesses included in kit (harness with blue connector) to Customer Connection module P5 and adapter board J19 per unit diagram.
 - For Voyager™ 3, connect one of the harnesses included in kit (harness with similar color connectors on both ends) to Customer Connection module P5 and unit controller P2 (Symbio™ 700) per unit diagram.

Note: The unit wiring diagram is located on the control box high voltage door.

6. Close the access panel.
7. Apply the information label next to the unit nameplate.
8. Connect power to the unit. Refer to the troubleshooting section in the unit installation guide, if needed.

Trane and American Standard create comfortable, energy efficient indoor environments for commercial and residential applications. For more information, please visit trane.com or americanstandardair.com.

Trane and American Standard have a policy of continuous product and product data improvement and reserve the right to change design and specifications without notice. We are committed to using environmentally conscious print practices.

ACC-SVN245B-EN 12 Nov 2022
Supersedes ACC-SVN245A-EN (August 2022)

©2022