

# Installation Instructions

## Low Ambient Control

### Precedent™ Packaged Rooftop Units

### 3 to 25 Tons

**Model Numbers:**

FIALOAM001\*

FIALOAM002\*

**Used With:**

3 to 25 tons T/Y models with Symbio™ controls

3 to 25 tons W/D models with Symbio controls

#### SAFETY WARNING

Only qualified personnel should install and service the equipment. The installation, starting up, and servicing of heating, ventilating, and air-conditioning equipment can be hazardous and requires specific knowledge and training. Improperly installed, adjusted or altered equipment by an unqualified person could result in death or serious injury. When working on the equipment, observe all precautions in the literature and on the tags, stickers, and labels that are attached to the equipment.

# Introduction

Read this manual thoroughly before operating or servicing this unit.

## Warnings, Cautions, and Notices

Safety advisories appear throughout this manual as required. Your personal safety and the proper operation of this machine depend upon the strict observance of these precautions.

The three types of advisories are defined as follows:

- ⚠ WARNING** Indicates a potentially hazardous situation which, if not avoided, could result in death or serious injury.
- ⚠ CAUTION** Indicates a potentially hazardous situation which, if not avoided, could result in minor or moderate injury. It could also be used to alert against unsafe practices.
- NOTICE** Indicates a situation that could result in equipment or property-damage only accidents.

## Important Environmental Concerns

Scientific research has shown that certain man-made chemicals can affect the earth's naturally occurring stratospheric ozone layer when released to the atmosphere. In particular, several of the identified chemicals that may affect the ozone layer are refrigerants that contain Chlorine, Fluorine and Carbon (CFCs) and those containing Hydrogen, Chlorine, Fluorine and Carbon (HCFCs). Not all refrigerants containing these compounds have the same potential impact to the environment. Trane advocates the responsible handling of all refrigerants.

## Important Responsible Refrigerant Practices

Trane believes that responsible refrigerant practices are important to the environment, our customers, and the air conditioning industry. All technicians who handle refrigerants must be certified according to local rules. For the USA, the Federal Clean Air Act (Section 608) sets forth the requirements for handling, reclaiming, recovering and recycling of certain refrigerants and the equipment that is used in these service procedures. In addition, some states or municipalities may have additional requirements that must also be adhered to for responsible management of refrigerants. Know the applicable laws and follow them.

**⚠ WARNING**

**Proper Field Wiring and Grounding Required!**

Failure to follow code could result in death or serious injury. All field wiring **MUST** be performed by qualified personnel. Improperly installed and grounded field wiring poses **FIRE** and **ELECTROCUTION** hazards. To avoid these hazards, you **MUST** follow requirements for field wiring installation and grounding as described in **NEC** and your local/state/national electrical codes.

**⚠ WARNING**

**Personal Protective Equipment (PPE) Required!**

Failure to wear proper PPE for the job being undertaken could result in death or serious injury. Technicians, in order to protect themselves from potential electrical, mechanical, and chemical hazards, **MUST** follow precautions in this manual and on the tags, stickers, and labels, as well as the instructions below:

- Before installing/servicing this unit, technicians **MUST** put on all PPE required for the work being undertaken (Examples; cut resistant gloves/sleeves, butyl gloves, safety glasses, hard hat/bump cap, fall protection, electrical PPE and arc flash clothing). **ALWAYS** refer to appropriate Safety Data Sheets (SDS) and OSHA guidelines for proper PPE.
- When working with or around hazardous chemicals, **ALWAYS** refer to the appropriate SDS and OSHA/GHS (Global Harmonized System of Classification and Labeling of Chemicals) guidelines for information on allowable personal exposure levels, proper respiratory protection and handling instructions.
- If there is a risk of energized electrical contact, arc, or flash, technicians **MUST** put on all PPE in accordance with OSHA, NFPA 70E, or other country-specific requirements for arc flash protection, **PRIOR** to servicing the unit. **NEVER PERFORM ANY SWITCHING, DISCONNECTING, OR VOLTAGE TESTING WITHOUT PROPER ELECTRICAL PPE AND ARC FLASH CLOTHING. ENSURE ELECTRICAL METERS AND EQUIPMENT ARE PROPERLY RATED FOR INTENDED VOLTAGE.**

**⚠ WARNING**

**Follow EHS Policies!**

Failure to follow instructions below could result in death or serious injury.

- All Trane personnel must follow the company's Environmental, Health and Safety (EHS) policies when performing work such as hot work, electrical, fall protection, lockout/tagout, refrigerant handling, etc. Where local regulations are more stringent than these policies, those regulations supersede these policies.
- Non-Trane personnel should always follow local regulations.

**⚠ WARNING**

**R-454B Flammable A2L Refrigerant!**

Failure to use proper equipment or components as described below could result in equipment failure, and possibly fire, which could result in death, serious injury, or equipment damage.

The equipment described in this manual uses R-454B refrigerant which is flammable (A2L). Use ONLY R-454B rated service equipment and components. For specific handling concerns with R-454B, contact your local representative.

## Copyright

This document and the information in it are the property of Trane, and may not be used or reproduced in whole or in part without written permission. Trane reserves the right to revise this publication at any time, and to make changes to its content without obligation to notify any person of such revision or change.

## Trademarks

All trademarks referenced in this document are the trademarks of their respective owners.

## Revision History

- Used with model number information updated.
- Updated General Information chapter.
- Updated Temperature Sensor Installation and Control Box Wiring topics in Installation chapter.

# General Information

- Carefully review installation instructions.
- This instruction covers installation of the low ambient kit on Precedent units with 3 phase fixed speed condenser fan motor(s).

## **NOTICE**

### **Motor Damage**

**Use of this kit on units with variable speed condenser fan motors could cause motor damage.  
Do NOT use on units with variable speed condenser fan motors.**

## Inspection

1. Unpack all components of the kit.
2. Check carefully for shipping damage. If any damage is found, report it immediately, and file a claim against the transportation company.

## Parts List

**Table 1. Parts list**

<b>Qty</b>	<b>Description</b>
1	Low ambient control module
1	Control mounting bracket
2	8-32 x 1 in. screws
2	10-16 x 0.5 in. screws
1	Temperature sensor
1	Pressure transducer
1	Pressure tap tee
1	Rubber grommet
1	Outdoor motor power harness
1	Control power harness
1	Temperature sensor harness
1	Temperature sensor extension harness
1	Schematic
1	Installation instructions
1	Installed accessory label
1	Valve control harness (FIALOAM002* only)

# Installation

**Table 2. Low ambient controller ratings**

Volts, AC	208, 240, 380, 415, 480, 600
Control voltage	18-30 Vac
Frequency	50-60 Hz
Operating temperature	-40°F + 140°F (-40°C to 60°C)
Full load Amps	10 Amps
Transducer pressure control range	0-500 psi

## Controller

**⚠ WARNING**

**Hazardous Voltage w/Capacitors!**

Failure to disconnect power and discharge capacitors before servicing could result in death or serious injury. Disconnect all electric power, including remote disconnects and discharge all motor start/run capacitors before servicing. Follow proper lockout/tagout procedures to ensure the power cannot be inadvertently energized. Verify with a CAT III or IV voltmeter rated per NFPA 70E that all capacitors have discharged.

1. Disconnect all power from the unit.
2. Remove the compressor and control box access panel(s).
3. Use 8-32 × 1-inch screws to mount the controller bracket. See [Figure 1](#) for orientation.

**Figure 1. Mounting location**



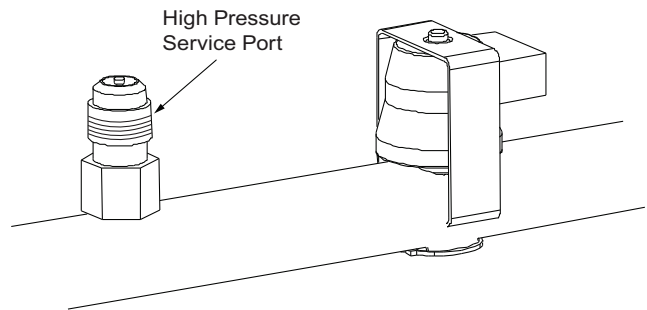
4. Open the left-side, low voltage door to access the high voltage section. This is where the controller/bracket will be mounted. See [Figure 1](#) for mounting location.
5. Use 10-16 × 0.5-inch screws to mount the assembly to the control box back panel.

**Note:** The right side of the assembly will slide into the slot in the back panel. Secure the left side with screws (supplied in the kit).

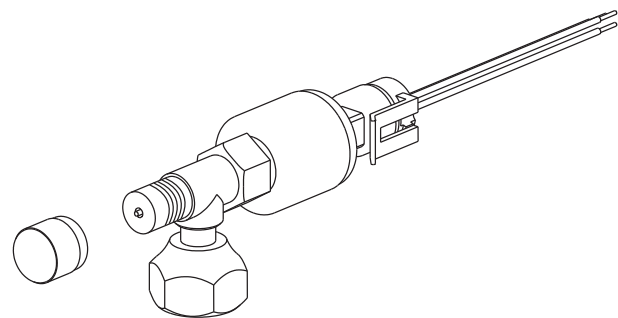
## Pressure Transducer

1. Install the supplied tee on the high pressure service port. See [Figure 2](#).
  - a. Remove cap nut from high pressure service port.
  - b. Install the pressure sensor on one of the Tee ports. See [Figure 3](#).
  - c. Place the tee flare nut with the valve core depressor on the high pressure tap. See [Figure 4](#).
  - d. Tighten flare nut securely to the high pressure service port and check for leaks.
  - e. Place cap nut on open port tee.
  - f. Route wires along with existing sensor wires into main control box. Refer to wire harness installation section for proper wire routing path back to controller mounting location.
  - g. Connect wires to the appropriate controller terminals. See schematic.

**Figure 2. High pressure service port**

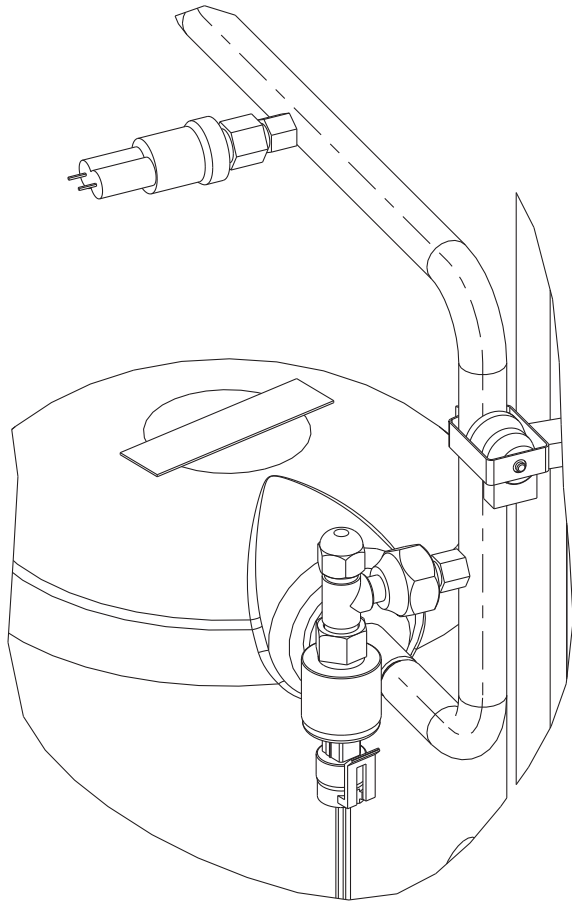


**Figure 3. Transducer to tee**



## Installation

**Figure 4. Tee and transducer installed on high pressure service port**



## Temperature Sensor Installation

### **⚠ WARNING**

#### **Hazardous Voltage w/Capacitors!**

Failure to disconnect power and discharge capacitors before servicing could result in death or serious injury. Disconnect all electric power, including remote disconnects and discharge all motor start/run capacitors before servicing. Follow proper lockout/tagout procedures to ensure the power cannot be inadvertently energized. Verify with a CAT III or IV voltmeter rated per NFPA 70E that all capacitors have discharged.

The existing thermistor, used by the unit controls, measures the outdoor ambient air temperature.

- 3 to 12.5 tons - existing thermistor is mounted on the condenser base pan in front of the compressors.
- 12.5 to 25 tons - existing thermistor is mounted in the lower, right corner of the main control box.

The low ambient controller requires a second thermistor. Both locations are factory designed with a second hole for the controller temperature sensor.

1. Install grommet in second hole located next to existing temperature.
2. Insert controller temperature sensor in grommet. Confirm majority of the sensor is pushed through the grommet.

## Control Box Wiring

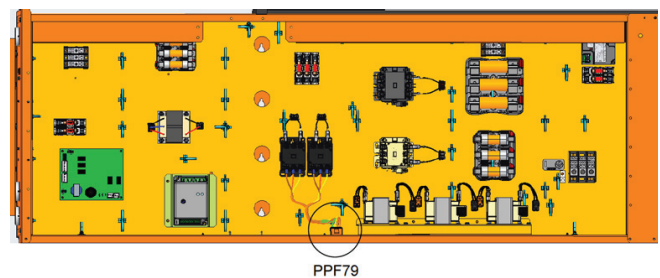
### **⚠ WARNING**

#### **Hazardous Voltage w/Capacitors!**

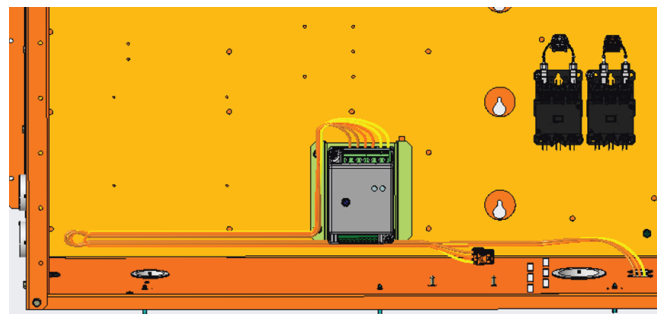
Failure to disconnect power and discharge capacitors before servicing could result in death or serious injury. Disconnect all electric power, including remote disconnects and discharge all motor start/run capacitors before servicing. Follow proper lockout/tagout procedures to ensure the power cannot be inadvertently energized. Verify with a CAT III or IV voltmeter rated per NFPA 70E that all capacitors have discharged.

1. Disconnect outdoor motor (ODM1) from power circuit.
  - a. Unplug orange fan motor connector (PPM79) from underneath control box.
  - b. Remove orange fan motor connector (PPF79) from sheet metal opening in control box wrapper.

**Figure 5. Panel mount connector location**

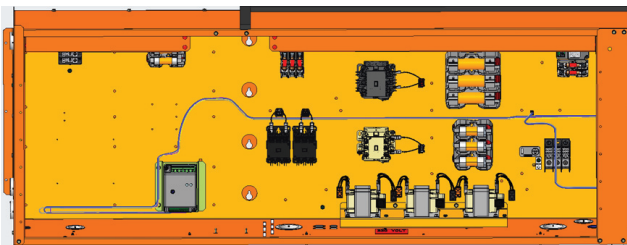


**Figure 6. Outdoor motor power harness**



2. Install outdoor motor harness in control box as shown in [Figure 6](#).
  - a. Plug (PPF79) from outdoor fan contactor 1 (OFC1) into kit supplied power harness (PPM79B).
  - b. Snap kit supplied (PPF79B) into the control box wrapper where fan motor connector (PPF79) was originally placed.
  - c. Plug fan motor connector (PPM79) into power harness (PPF79B).
  - d. Refer to schematic for connection points and install remaining strip lead connections into controller.

**Figure 7. Control power harness**



3. Install control power harness in control box as shown in [Figure 7](#).
  - a. Install gray and blue wires for control power harness to controller. Refer to schematic for wire connections.
    - i. For heat pump units, install black wire from valve control harness to REV VALVE terminal at this time.
  - b. Route harness across back panel and up onto right low voltage door to the adapter board.
    - i. Route valve control harness with control power harness to the adapter board.

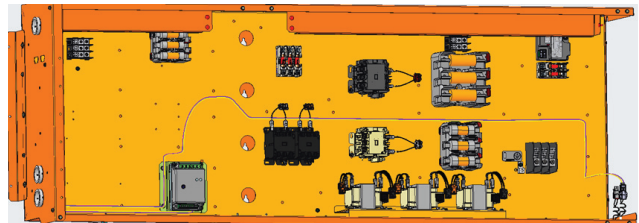
**Note:** Following existing wiring paths to adapter board but routing through horseshoe shaped opening on low voltage door. All harnesses in this kit utilize the factory installed releasable wire ties in all wiring paths. To release zip ties, pull up on tab near head of zip tie and push loose end of zip tie.

  - c. Connect P6 from control power harness to AB-J6. Refer to main unit schematic sheet 4.
  - d. For heat pump units, remove J11 connector from Symbio™ controller and plug into PPM11 plug on valve control harness. Plug J11 from valve control harness into Symbio P11 plug.
4. Temperature sensor harness
  - a. Install temperature sensor harness in control box as shown in [Figure 8](#).
  - b. Refer to schematic and connect wires to appropriate terminals on the controller.
  - c. Route harness across back panel and into lower right corner.
    - 3 to 12.5 tons - use temperature sensor extension harness to continue routing down to sensor location.
    - 15 to 25 tons - connect to sensor previously mounted in control box.
  - d. Connect harness to temperature sensor connector.

### 5. Final wiring

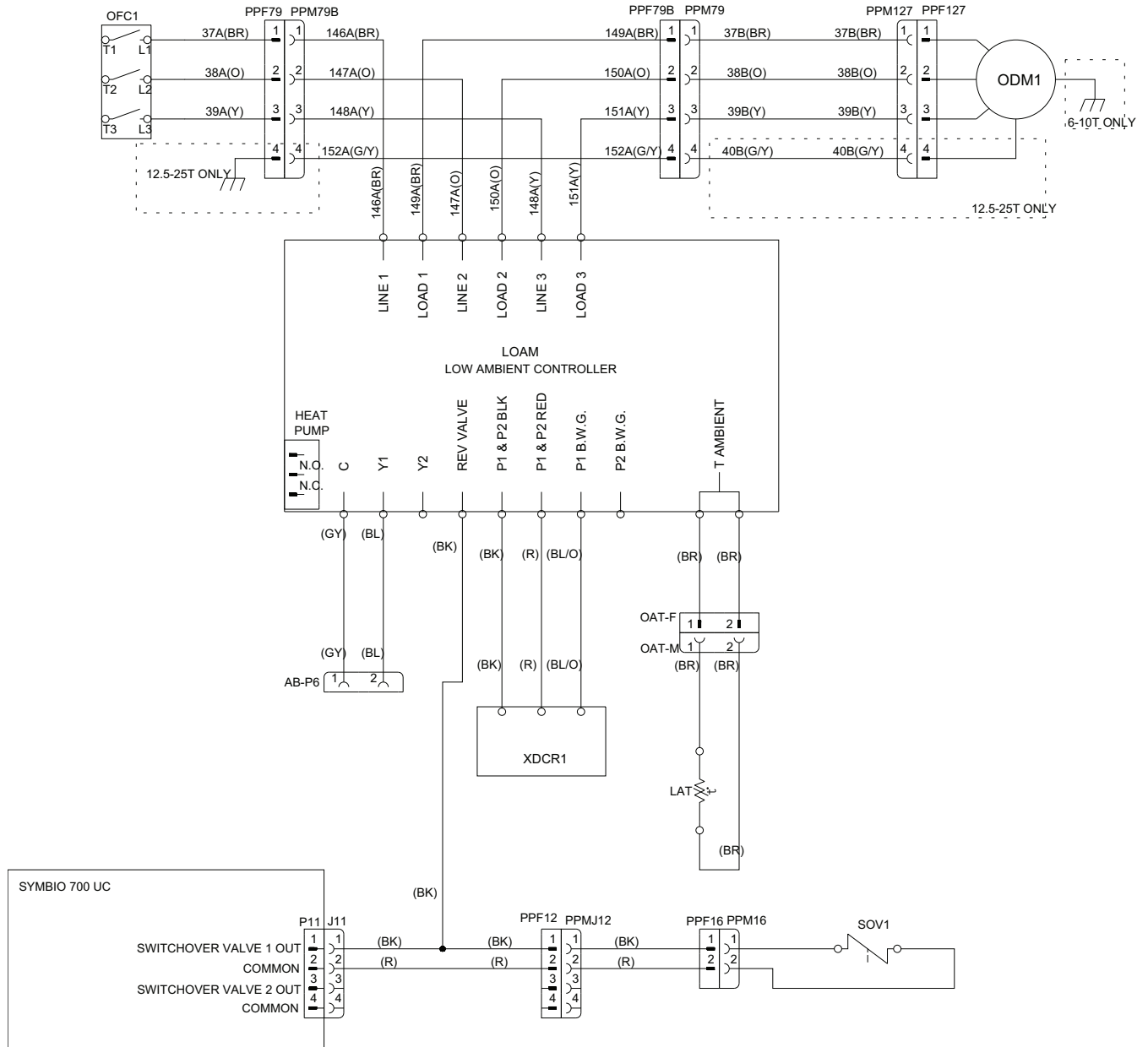
Secure installed wires with wire ties.

**Figure 8. Temperature sensor harness**



# Installation

**Figure 9. Low ambient controller**



REF DES	DESCRIPTION	LINE NO
LAT	LOW AMBIENT TEMP SENSOR	38
LOAM	LOW AMBIENT MODULE	24
ODM1	OUTDOOR FAN MOTOR	19
OFC1	OUTDOOR FAN CONTACTOR	18
SOV1	SWITCH OVER VALVE	40
SYMBIO	SYMBIO 700 UC	41
XDCR1	PRESSURE TRANSDUCER CKT1	34

CODE	COLOR	CODE	COLOR
BK	BLACK	PK	PINK
BL	BLUE	R	RED
BR	BROWN	TQ	TURQUOISE
G	GREEN	V(PR)	PURPLE
GY	GREY	W	WHITE
O	ORANGE	Y	YELLOW

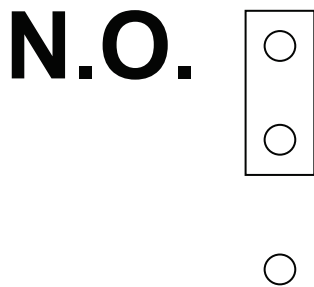


# Controller Settings and Operation

## Jumper Position

- For non-heat pump applications, the heat pump select jumper must be in the default normally open (N.O.) position, and the **REV. VALVE** terminal must not be connected.
- For heat pump applications, move the jumper to the normally closed (N.C.) position and wire the **REV. VALVE** terminal with the REV Valve harness included in the kit.

Figure 10. Default jumper position



## Controller Operation

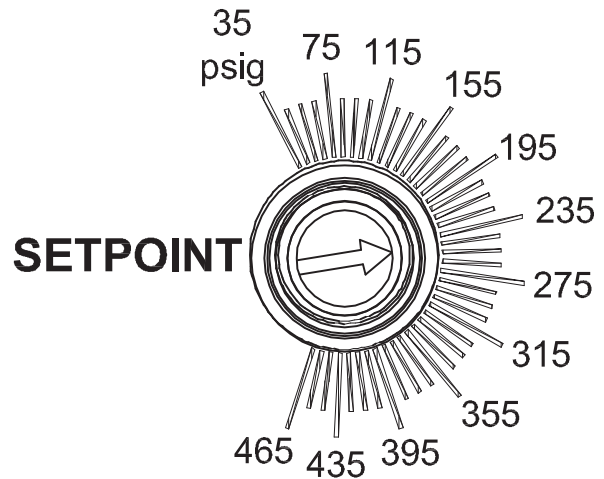
- The LOAM controller is used to maintain head pressure within an acceptable range when ambient temperature falls below 50°F. It reads discharge pressures from refrigeration circuits.
- It cycles outdoor fan motors on and off to maintain the highest of the two discharge pressures at the selected setpoint anytime one or more compressors are operating. Above 50° F, fans will be energized continuously.

## Pressure Setpoint

Set the pressure setpoint to the recommended value of 245 psig (see [Figure 11, p. 9](#)).

At ambient temperatures lower than 50°F, the controller will maintain discharge pressures between 15 psig above and 15 psig below dialed pressure setpoint.

Figure 11. Pressure setpoint



## Labels

Apply self-adhesive labels supplied with the kit to the inside of the panel covering the main control box:

1. Accessory label: Apply near the unit nameplate.
2. Supplementary wiring diagram label: Schematic can be placed in schematic pouch already located on back of right side low voltage door that contains all main unit schematics.

## Close-Up, Fan Inspection, and Restart

1. Inspect condenser fans:
  - a. Manually rotate the condenser fans to ensure free movement and check motor bearings for wear.
  - b. Verify that all fan mounting hardware and fan hubs are tight.
2. Connect all power to the unit.

# Troubleshooting

Confirm the unit is operating properly through the desired pressure range.

**Table 3. Troubleshooting guide**

Problem	Possible Cause	Possible Solution
No fan operation	No 24 volt control voltage	Check for 24 Vac at control and verify correct wiring. If wired correctly, check voltage across the transformer.
	No line voltage	Check voltage across the brown, orange, and yellow OD motor leads. If no line voltage is present, verify all wiring is correct.
Improper fan operation	Heat pump jumper not configured correctly	Refer to the IOM or correct hook-up diagram and verify the heat pump jumper is configured correctly.
	Control is not wired correctly	See wiring diagrams. Ensure that the 24 Vac power supply is connected in-phase with the motor power supply.
No fan modulation	No need to modulate the fan	If pressure is equal to or greater than the head pressure control setpoint, the fan will be operating at full speed.
	No input pressure to control	Check for proper transducer and Tee installation. Schrader valve depressor must depress Schrader valve enough to allow refrigerant into pressure transducer.
	Miswired	Check that the 24Vac signal and the transducer are wired up correctly into the controller.
Erratic fan operation	Control is not wired correctly	See wiring diagrams.
	Pressure transducer problem	Check for proper transducer and Tee installation. Schrader valve depressor must depress Schrader valve enough to allow refrigerant into pressure transducer.
	Dirty or blocked condenser coil	Clean condenser coil.
Fan motor is cycling on thermal overload	Dirty or blocked condenser coil	Clean condenser coil.
Unit fails to start	Incorrect/No voltage present	Using an AC voltmeter, measure the voltage between the 24 Vac terminals. It should read approximately 24 volts. Measure line voltage between LINE1, LINE2 and LINE 3 to confirm that line voltage is present.
	Transducer malfunction or not installed	If lights are flashing alternatively, then no probe is connected or the probe is malfunctioning. When using a pressure transducer, with power applied to the control, use a voltmeter to measure volts DC between COMM and P1 or P2, where the wire is connected. The reading should be according to <a href="#">Table 4</a> .
The fuse is blown and/or signs of damage on the unit	Miswired	The unit has been mis-wired and may be permanently damaged.

**Table 4. Pressure vs. voltage**

Pressure (psig)	Voltage (Vdc)
0	0.5
50	0.9
100	1.3
150	1.7
200	2.1
250	2.5
300	2.9
350	3.3
400	3.7
450	4.1
500	4.5



Trane and American Standard create comfortable, energy efficient indoor environments for commercial and residential applications. For more information, please visit [trane.com](http://trane.com) or [americanstandardair.com](http://americanstandardair.com).

Trane and American Standard have a policy of continuous product and product data improvement and reserve the right to change design and specifications without notice. We are committed to using environmentally conscious print practices.