

Installation Instructions

Power Exhaust Kit – Standard and Low Leak Economizers

Precedent™ Packaged Rooftop Units 3 to 25 Tons

Note: See “Wiring Installation – FIAPWRX*01/02*” on page 9 for economizer actuator note.

Model Numbers:	Used With:
FIAPWRX301*	Precedent A cabinet (Digit 39 = A), 230V (Digit 7 = 3)
FIAPWRX302*	Precedent B and C cabinet (Digit 39 = B, C), 230V (Digit 7 = 3)
FIAPWRX303*	Precedent D cabinet (Digit 39 = D), 230V (Digit 7 = 3)
FIAPWRX401*	Precedent A cabinet (Digit 39 = A), 460V (Digit 7 = 4)
FIAPWRX402*	Precedent B and C cabinet (Digit 39 = B, C), 460V (Digit 7 = 4)
FIAPWRX403*	Precedent D cabinet (Digit 39 = D), 460V (Digit 7 = 4)
FIAPWRXW01*	Precedent A cabinet (Digit 39 = A), 575V (Digit 7 = W)
FIAPWRXW02*	Precedent B and C cabinet (Digit 39 = B, C), 575V (Digit 7 = W)
FIAPWRXW03*	Precedent D cabinet (Digit 39 = D), 575V (Digit 7 = W)

SAFETY WARNING

Only qualified personnel should install and service the equipment. The installation, starting up, and servicing of heating, ventilating, and air-conditioning equipment can be hazardous and requires specific knowledge and training. Improperly installed, adjusted or altered equipment by an unqualified person could result in death or serious injury. When working on the equipment, observe all precautions in the literature and on the tags, stickers, and labels that are attached to the equipment.

Introduction

Read this manual thoroughly before operating or servicing this unit.

Warnings, Cautions, and Notices

Safety advisories appear throughout this manual as required. Your personal safety and the proper operation of this machine depend upon the strict observance of these precautions.

The three types of advisories are defined as follows:

- ⚠ WARNING** Indicates a potentially hazardous situation which, if not avoided, could result in death or serious injury.
- ⚠ CAUTION** Indicates a potentially hazardous situation which, if not avoided, could result in minor or moderate injury. It could also be used to alert against unsafe practices.
- NOTICE** Indicates a situation that could result in equipment or property-damage only accidents.

Important Environmental Concerns

Scientific research has shown that certain man-made chemicals can affect the earth's naturally occurring stratospheric ozone layer when released to the atmosphere. In particular, several of the identified chemicals that may affect the ozone layer are refrigerants that contain Chlorine, Fluorine and Carbon (CFCs) and those containing Hydrogen, Chlorine, Fluorine and Carbon (HCFCs). Not all refrigerants containing these compounds have the same potential impact to the environment. Trane advocates the responsible handling of all refrigerants.

Important Responsible Refrigerant Practices

Trane believes that responsible refrigerant practices are important to the environment, our customers, and the air conditioning industry. All technicians who handle refrigerants must be certified according to local rules. For the USA, the Federal Clean Air Act (Section 608) sets forth the requirements for handling, reclaiming, recovering and recycling of certain refrigerants and the equipment that is used in these service procedures. In addition, some states or municipalities may have additional requirements that must also be adhered to for responsible management of refrigerants. Know the applicable laws and follow them.

⚠ WARNING

Proper Field Wiring and Grounding Required!

Failure to follow code could result in death or serious injury. All field wiring **MUST** be performed by qualified personnel. Improperly installed and grounded field wiring poses **FIRE** and **ELECTROCUTION** hazards. To avoid these hazards, you **MUST** follow requirements for field wiring installation and grounding as described in **NEC** and your local/state/national electrical codes.

⚠ WARNING

Personal Protective Equipment (PPE) Required!

Failure to wear proper PPE for the job being undertaken could result in death or serious injury. Technicians, in order to protect themselves from potential electrical, mechanical, and chemical hazards, **MUST** follow precautions in this manual and on the tags, stickers, and labels, as well as the instructions below:

- Before installing/servicing this unit, technicians **MUST** put on all PPE required for the work being undertaken (Examples; cut resistant gloves/sleeves, butyl gloves, safety glasses, hard hat/bump cap, fall protection, electrical PPE and arc flash clothing). **ALWAYS** refer to appropriate Safety Data Sheets (SDS) and OSHA guidelines for proper PPE.
- When working with or around hazardous chemicals, **ALWAYS** refer to the appropriate SDS and OSHA/GHS (Global Harmonized System of Classification and Labeling of Chemicals) guidelines for information on allowable personal exposure levels, proper respiratory protection and handling instructions.
- If there is a risk of energized electrical contact, arc, or flash, technicians **MUST** put on all PPE in accordance with OSHA, NFPA 70E, or other country-specific requirements for arc flash protection, **PRIOR** to servicing the unit. **NEVER PERFORM ANY SWITCHING, DISCONNECTING, OR VOLTAGE TESTING WITHOUT PROPER ELECTRICAL PPE AND ARC FLASH CLOTHING. ENSURE ELECTRICAL METERS AND EQUIPMENT ARE PROPERLY RATED FOR INTENDED VOLTAGE.**

⚠ WARNING

Follow EHS Policies!

Failure to follow instructions below could result in death or serious injury.

- All Trane personnel must follow the company's Environmental, Health and Safety (EHS) policies when performing work such as hot work, electrical, fall protection, lockout/tagout, refrigerant handling, etc. Where local regulations are more stringent than these policies, those regulations supersede these policies.
- Non-Trane personnel should always follow local regulations.

⚠ WARNING

R-454B Flammable A2L Refrigerant!

Failure to use proper equipment or components as described below could result in equipment failure, and possibly fire, which could result in death, serious injury, or equipment damage.

The equipment described in this manual uses R-454B refrigerant which is flammable (A2L). Use ONLY R-454B rated service equipment and components. For specific handling concerns with R-454B, contact your local representative.

Copyright

This document and the information in it are the property of Trane, and may not be used or reproduced in whole or in part without written permission. Trane reserves the right to revise this publication at any time, and to make changes to its content without obligation to notify any person of such revision or change.

Trademarks

All trademarks referenced in this document are the trademarks of their respective owners.

Revision History

- Used with information updated on the front cover.
- Updated installation instructions for FIAPWRX*01/02*.
- Updated Wiring Installation FIAPWRX*01/02*/03*.

Table of Contents

General Information	5
Inspection	5
Parts List	5
Installation – FIAPWRX*01/02*	6
Pre-Installation	6
Standard Economizer	6
Low Leak Economizer	8
Power Exhaust	8
Wiring Installation – FIAPWRX*01/02*	9
Symbio™ Controls Wiring	10
Power Wiring	10
Close Out	10
Installation – FIAPWRX*03*	11
Parts List	11
Internal Block-off Gasket Seals	12
Comparative Enthalpy Install	12
Block-off Assembly	12
Power Exhaust Assembly	13
Wiring Installation – FIAPWRX*03*	16
Power Wiring	16
Control Wiring	16
Power Exhaust Settings with Single Zone VAV and Multi-Speed Units	18
Weights and Dimensions	18

General Information

Carefully review installation instructions. Power exhaust is designed for downflow applications¹. If the installation is for horizontal duct connections, the power exhaust may be mounted on the horizontal return duct. An economizer or motorized damper must be installed and functional before attempting to install the power exhaust.

The power exhaust can be turned **ON** at infinite fresh air damper settings depending on how the unit is configured.

Inspection

1. Unpack all components of the kit.
2. Check carefully for shipping damage. If any damage is found, report it immediately, and file a claim against the transportation company.

Parts List

Table 1. Parts list

Qty	Description
1	Power exhaust assembly
1	Power exhaust hood (three pieces)
1	Template drawing
1	Gasket
1	Sealant; silicone rubber
14	10-16 x 0.50; Screw
12	#10 - 0.62 (self tapping); Screw
2	Bushing
1	Edge protector
1	Label
8	Wire tie; pop-in
2	Wire tie
1	# 6-19 x 0.625; Econ logic mounting screw

¹ Downflow application only is possible for units with low leak economizers.

Installation – FIAPWRX*01/02*

⚠ WARNING

Hazardous Voltage w/Capacitors!

Failure to disconnect power and discharge capacitors before servicing could result in death or serious injury. Disconnect all electric power, including remote disconnects and discharge all motor start/run capacitors before servicing. Follow proper lockout/tagout procedures to ensure the power cannot be inadvertently energized. For variable frequency drives or other energy storing components provided by Trane or others, refer to the appropriate manufacturer's literature for allowable waiting periods for discharge of capacitors. Verify with a CAT III or IV voltmeter rated per NFPA 70E that all capacitors have discharged.

Pre-Installation

1. Open and lock unit disconnect before attempting to install this accessory.
2. Remove the filter access panel from front side of the unit.
3. Remove the compressor access panel from front side of the unit.
4. Remove the return air panel from back side of the unit.

Standard Economizer

Use the template for the return air panel provided in the hardware kit to locate positions to drill holes and cut required new opening.

Note: Use template that corresponds to unit/return panel size. Do not cut a hole for units that have a low leak economizer installed.

Recommended Procedure

Place the template into position for drilling and cutting, and secure it with pieces of duct tape (field supplied).

Important: Alignment of the template is critical. Instructions for alignment and cutting are printed on the template.

1. Drill three 1/8-inch holes in the template and panel for engagement holes. Refer to template.

Figure 1. Power exhaust hood installation for standard economizer

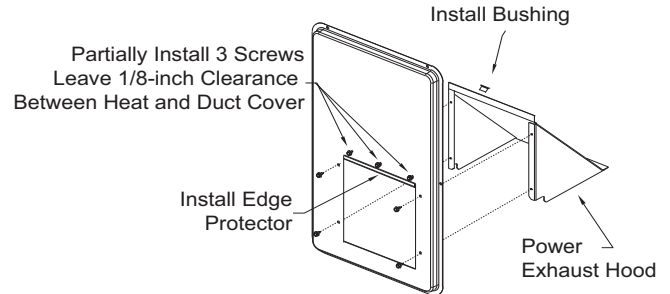

2. Drill four holes through the template and panel for saw cutting starter holes. Cut through the template and panel at the same time to create the new opening; discard the scrap metal.
3. Install edge protector (supplied) along the down-facing top edge of the new cutout. See [Figure 1](#).
4. Assemble required power exhaust hood with screws provided as shown in [Figure 1](#).
5. Mount hood to duct cover with four screws. See [Figure 1](#).
6. Insert 1-inch bushing into hood. See [Figure 1](#).
7. Partially insert screws into the three engagement holes drilled in the duct cover. Leave approximately 1/8-inch gap between the screw head and duct cover. These will act as alignment hangers. See [Figure 1](#).

Important: Remove the return duct block-off. Refer to [Figure 2](#).

Figure 2. Duct block-off

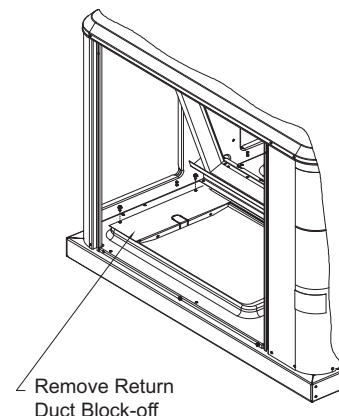

8. Install duct cover back on unit.
9. Apply gasket to face of power exhaust assembly. See [Figure 3](#).

Figure 3. Gasket to power exhaust assembly

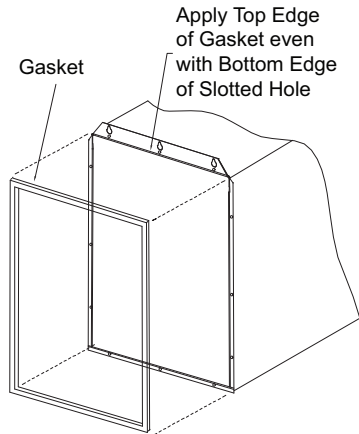

10. Pull wiring harness out from power exhaust assembly and insert through bushing in the hood.
11. Lift power exhaust assembly up and align slots in the top flange with screws in duct cover.
12. Secure the three screws.
13. Use the seven clearance holes on the perimeter flange and secure to the duct panel with seven self drilling screws.
14. Route the wire harness along the top edge of the economizer and secure with pop-in wire ties. See Figure 4.

Figure 4. Wire harness routing

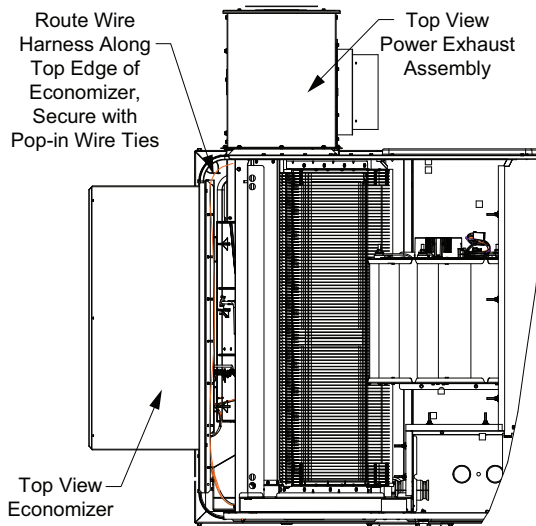

15. For all units, route the wires for the power exhaust into the return control box located in the return section of the unit. Refer to Figure 5.

Figure 5. Return control box location



Figure 6. Return control box view

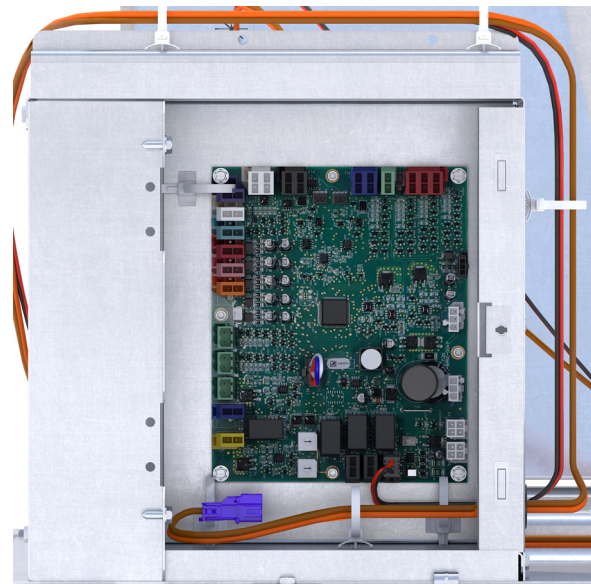

⚠ WARNING

Hazardous Voltage w/Capacitors!

Failure to disconnect power and discharge capacitors before servicing could result in death or serious injury. Disconnect all electric power, including remote disconnects and discharge all motor start/run capacitors before servicing. Follow proper lockout/tagout procedures to ensure the power cannot be inadvertently energized. For variable frequency drives or other energy storing components provided by Trane or others, refer to the appropriate manufacturer's literature for allowable waiting periods for discharge of capacitors. Verify with a CAT III or IV voltmeter rated per NFPA 70E that all capacitors have discharged.

Low Leak Economizer

Figure 7. Low leak install

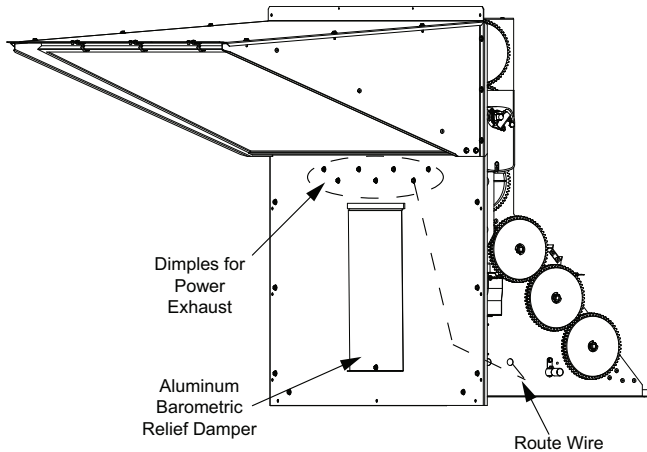

Power Exhaust

1. Remove aluminum barometric relief hood blade (if installed) and discard.
2. Open 1-inch hole near the gear side of the economizer and install 1-inch grommet.

Note: Grommet in economizer parts bag.

Figure 8. Gear side of the economizer

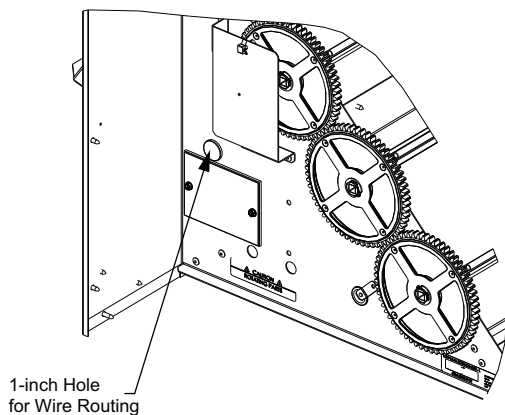

3. Partially insert self-drilling screws in three dimples above power exhaust opening and just below top economizer hood. See [Figure 9](#).

Note: Do not re-use barometric relief damper holes.

4. Install gasketing around perimeter of power exhaust assembly.
5. Route the power exhaust wire harness through the 1-inch hole near the gear side of the economizer.
6. Hang power exhaust on three partially inserted screws and remove the slack in wire harness.
7. Attach power exhaust with self-drilling screws. See [Figure 9](#).

8. Verify wire harness is clear of gears, doors, and any sharp edges of metal.
9. Route the wires for the power exhaust to the return control box location at the return portion of the unit. Refer to [Figure 5](#).

Figure 9. Power exhaust

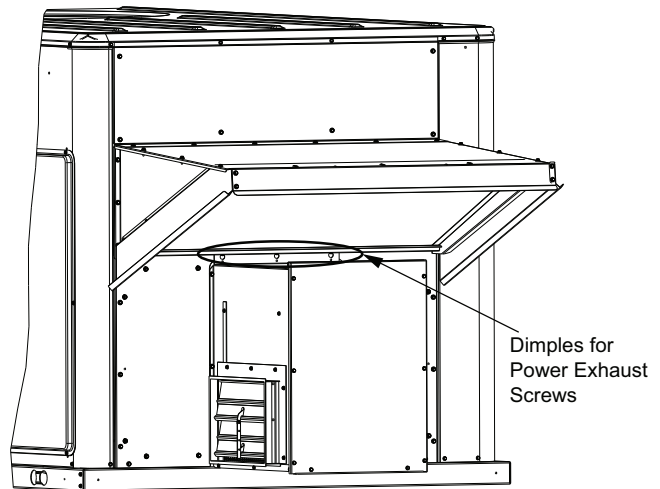

Wiring Installation – FIAPWRX*01/02*

⚠ WARNING

Proper Field Wiring and Grounding Required!

Failure to follow code could result in death or serious injury. All field wiring **MUST** be performed by qualified personnel. Improperly installed and grounded field wiring poses **FIRE** and **ELECTROCUTION** hazards. To avoid these hazards, you **MUST** follow requirements for field wiring installation and grounding as described in **NEC** and your local/state/national electrical codes.

NOTICE

Wire Damage!

Failure to follow instructions below could result in damaged wires. Use provided wire ties to make sure wires are secured and protected from sharp edges and hot surfaces.

Figure 10. Wiring

POWER WIRING

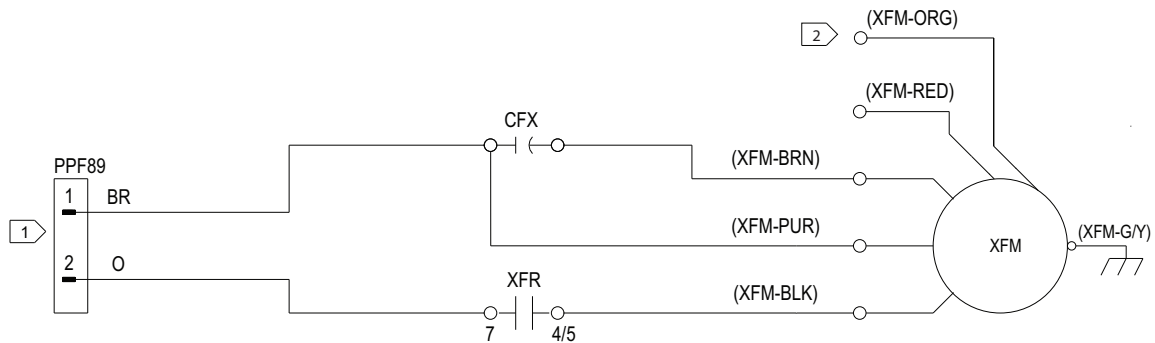

CONTROL WIRING

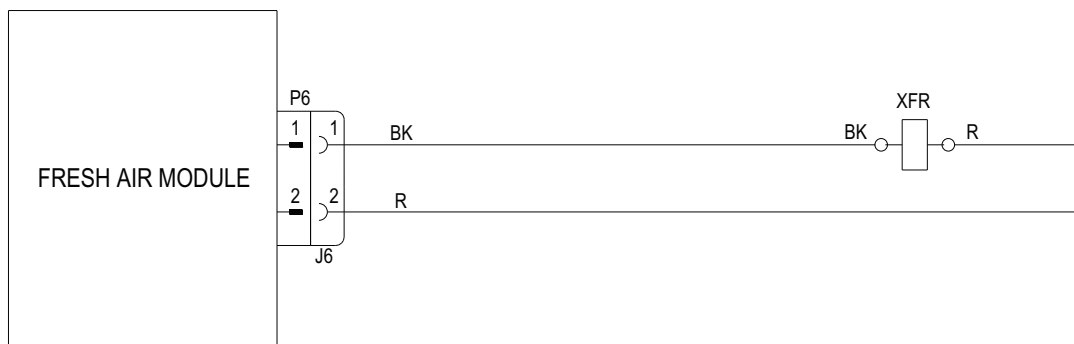

REF	DESCRIPTION
CFX	XFM CAPACITOR
XFM	EXHAUST FAN MOTOR
XFR	EXHAUST FAN RELAY

NOTES:

- 1 MATING CONNECTOR PPM89 IS LOCATED IN THE RETURN ENCLOSURE PANEL
- 2 460V/575V

Symbio™ Controls Wiring

⚠ WARNING

Hazardous Voltage w/Capacitors!

Failure to disconnect power and discharge capacitors before servicing could result in death or serious injury. Disconnect all electric power, including remote disconnects and discharge all motor start/run capacitors before servicing. Follow proper lockout/tagout procedures to ensure the power cannot be inadvertently energized. For variable frequency drives or other energy storing components provided by Trane or others, refer to the appropriate manufacturer's literature for allowable waiting periods for discharge of capacitors. Verify with a CAT III or IV voltmeter rated per NFPA 70E that all capacitors have discharged.

Refer to controls wiring diagram (Figure 10) for connections.

1. Route controls wiring (black and red) and connector J6 along the top of the return control box and down the right side and enter enclosure through the top hole for Precedent B/C/D cabinets or hole towards rear of enclosure for Precedent A cabinet.
2. Connect wire connector J6 to P6 on the fresh air options module in the return control box (brown connector). Secure wiring with pop-in wire ties. See Figure 6, p. 7.
3. After installation is complete, the Symbio™ 700 UC configuration will need to be updated to enable this installed feature.

Power Wiring

⚠ WARNING

Hazardous Voltage w/Capacitors!

Failure to disconnect power and discharge capacitors before servicing could result in death or serious injury. Disconnect all electric power, including remote disconnects and discharge all motor start/run capacitors before servicing. Follow proper lockout/tagout procedures to ensure the power cannot be inadvertently energized. For variable frequency drives or other energy storing components provided by Trane or others, refer to the appropriate manufacturer's literature for allowable waiting periods for discharge of capacitors. Verify with a CAT III or IV voltmeter rated per NFPA 70E that all capacitors have discharged.

Refer to the power diagrams for connections (Figure 10).

Important: Use provided wire ties to secure and protect wires from sharp edges, rotating parts, and hot surfaces.

1. Route the high voltage wiring (brown and orange) and purple connector (PPF89) along the top of the return control box and down the right side and enter enclosure through the bottom wire hole for Precedent B/C/D cabinets

or hole closest to front of enclosure for Precedent A cabinet.

2. Connect PPF89 to PPM89 (purple connector) and secure the wires with pop-in wire ties.

Close Out

⚠ WARNING

Hazardous Voltage w/Capacitors!

Failure to disconnect power and discharge capacitors before servicing could result in death or serious injury. Disconnect all electric power, including remote disconnects and discharge all motor start/run capacitors before servicing. Follow proper lockout/tagout procedures to ensure the power cannot be inadvertently energized. For variable frequency drives or other energy storing components provided by Trane or others, refer to the appropriate manufacturer's literature for allowable waiting periods for discharge of capacitors. Verify with a CAT III or IV voltmeter rated per NFPA 70E that all capacitors have discharged.

1. Open and lock unit disconnect.
2. Replace the filter access panel.
3. Place the 1-inch x 3-inch label (power exhaust installed) next to the main unit wiring diagram inside the compressor access panel.
4. Check all seams on the power exhaust and confirm they are all sealed water-tight with provided silicone rubber sealant.
5. Close the unit disconnect switch.

Installation – FIAPWRX*03*

Parts List

Figure 11. Major power exhaust components

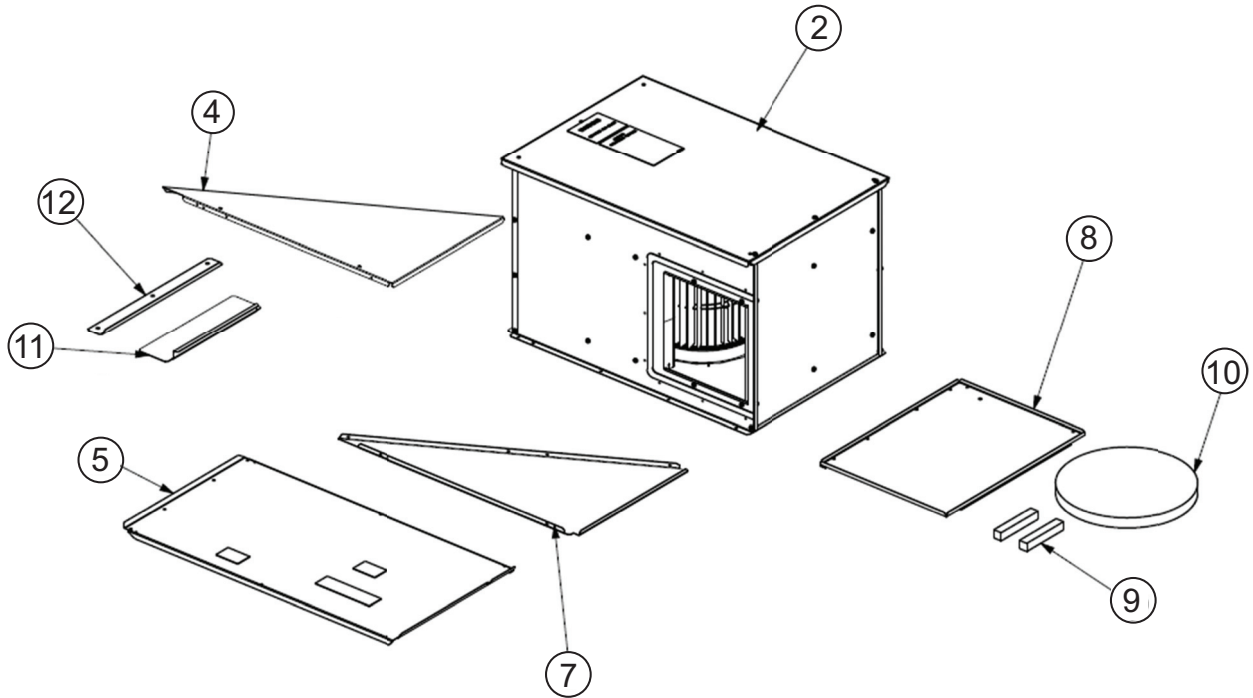

Table 2. Parts list

Item	Description	Qty
2	Power Exhaust Assembly	1
4	Internal Block-off, Right	1
5	Internal Block-off, Center	1
7	Internal Block-off, Left	1
8	Horizontal Return Block-off	1
9	1 in. x 1 in. x 6 in. Gasket	2
10	0.25 in. x 1.0 in. x 13 ft. Gasket	1
11	Internal Base Duct Block-off	1
12	Power Exhaust Alignment Bracket	1

Components not shown

Qty	Description
–	1/4 x 20 x 5/8, Screws
–	#10 x 14 x 3/4, Screws
1	7.78-in. Wire Tie
1	11.0-in. Wire Tie
1	0.94-in. ID; Bushing
1	0.56-in. ID; Bushing
1	1-in. x 3-in. power exhaust installed label

⚠ WARNING

Hazardous Service Procedures!

Failure to follow instructions could result in death or serious injury. The procedures recommended in this section of the manual could result in exposure to electrical, mechanical or other potential safety hazards. Always refer to the safety warnings provided throughout this manual concerning these procedures. When possible, disconnect all electrical power including remote disconnect and discharge all energy storing devices such as capacitors before servicing. Follow proper lockout/tagout procedures to ensure the power can not be inadvertently energized. When necessary to work with live electrical components, have a qualified licensed electrician or other individual who has been trained in handling live electrical components perform these tasks.

1. Open and lock unit disconnect before attempting to install this accessory.
2. Remove the filter access panel from front side of the unit.
3. Remove the horizontal duct cover.
4. Remove the economizer duct block-off.

Internal Block-off Gasket Seals

The following are two types of economizers:

1. Standard economizer: Attach one gasket (9) to the base, aligned with the economizer return air damper (RAD) bracket. See [Figure 12](#).

Figure 12. Attach gasket to base and block-off panel

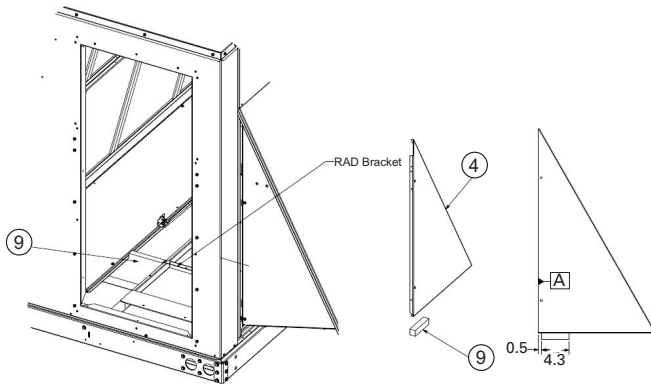

2. Low leak economizer: Align gasket with the return air damper flange. See [Figure 13](#).

Figure 13. Align gasket with RAD flange

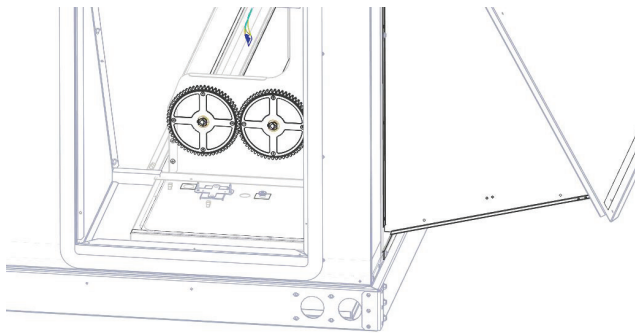

3. Cut one piece of gasket (9) to a length of 4.3-inch and attach to (4) leaving a gap of 0.5-inch from face A. See [Figure 12](#).

Comparative Enthalpy Install

1. Install humidity and temperature sensors as required. See [Figure 14](#).

Figure 14. Install comparative enthalpy and bushing

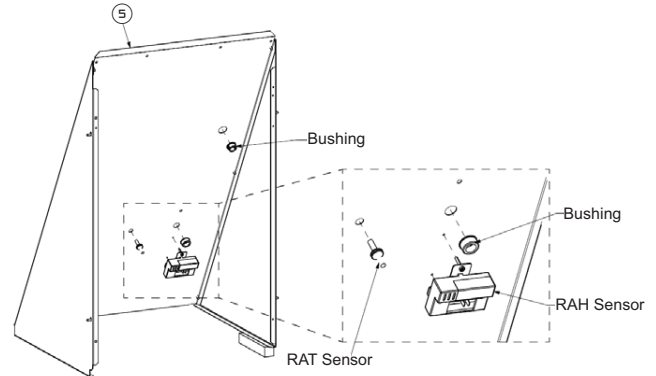

2. Install bushing in internal block-off panel. See [Figure 14](#).
3. Connect wires to humidity sensor and route wires through bushing. Wire tie leads to block-off to provide strain relief. (Wires to be routed with power exhaust leads back to the fresh air options module as described in later steps).

Block-off Assembly

1. Install internal base duct block-off using two screws.

Figure 15. Install base duct block-off panel

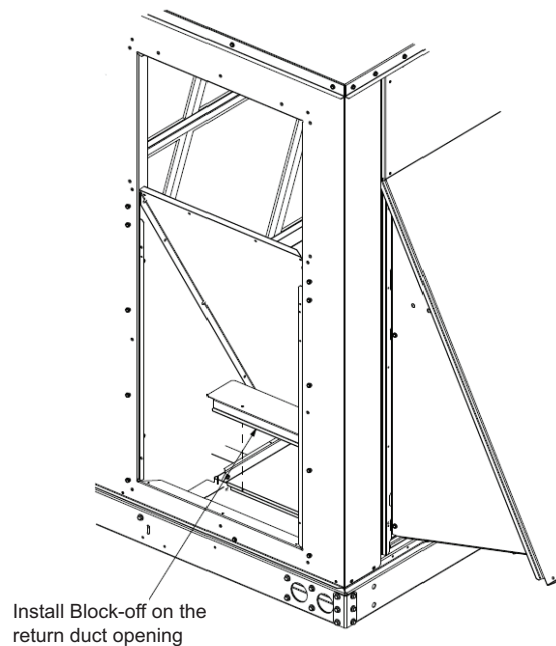

2. Attach internal block-off (4, 5 and 7) using six screws.

Figure 16. Block-off assembly

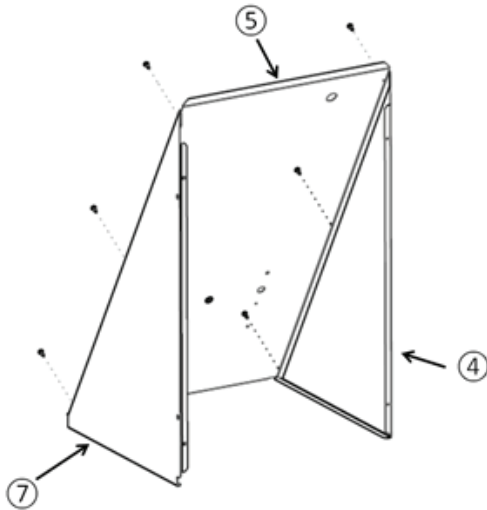

3. Install internal block-off assembly using four screws to secure to side flanges of return opening.

Figure 17. Secure internal block-off assembly

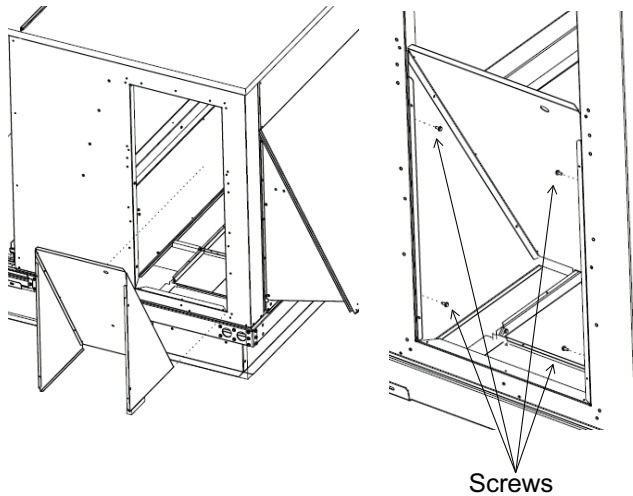

Power Exhaust Assembly

1. Remove center screw at bottom of rear panel duct opening.
2. Attach gasket (11) to unit back panel. Start gasket below the return horizontal duct opening, centered on the opening and aligned with the flange at the base rail. Route gasket to cover holes and dimples along sides and top of the duct opening. Gasket should be one continuous piece overlapping 1-inch at bottom center.

Figure 18. Remove screw and attach gasket

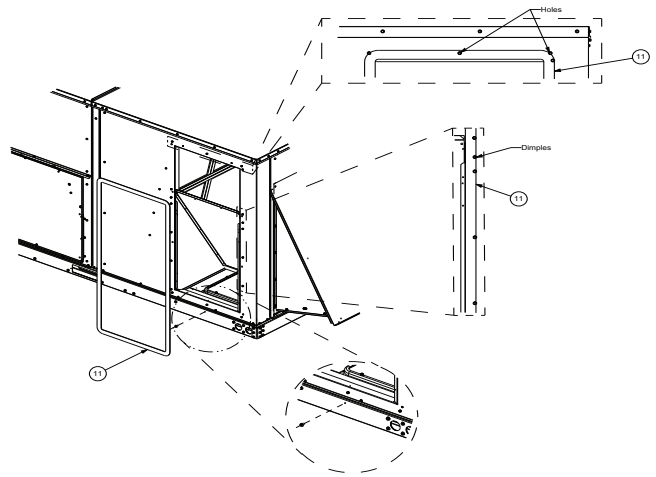

3. Install support and alignment bracket to base rail below return duct opening with three screws (1/4 x 5/8).

Figure 19. Install support and alignment bracket

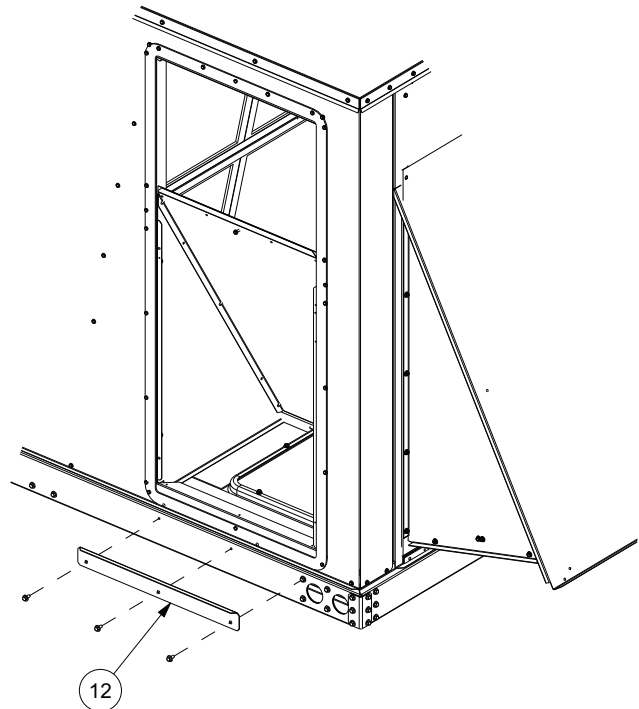

Installation – FIAPWRX*03*

4. Set power exhaust housing adjacent to return duct opening.
5. Uncoil wires and route through grommet in internal block-off. (Feed terminals through bushing one at a time).

The following are two types of economizers:

6. Standard economizer: Insert wire tie into closest hole in the economizer support channel and secure the power and control wires. See [Figure 20](#).

Figure 20. Standard economizer wire routing

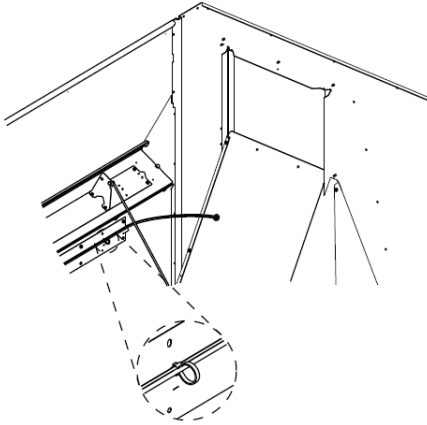

7. Low leak economizer: Route wiring along the bottom of the return air damper and secure the power and control wire. See [Figure 21](#).

Figure 21. Low leak economizer wire routing

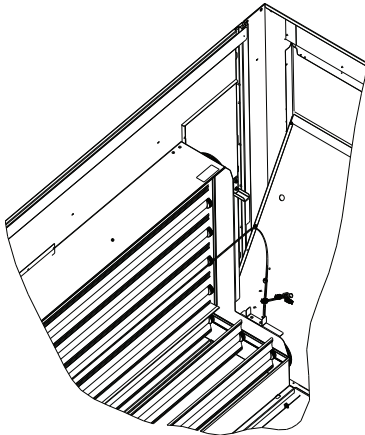

8. Attach power exhaust to side of unit using 10 screws.

Figure 22. Attach power exhaust to side of unit

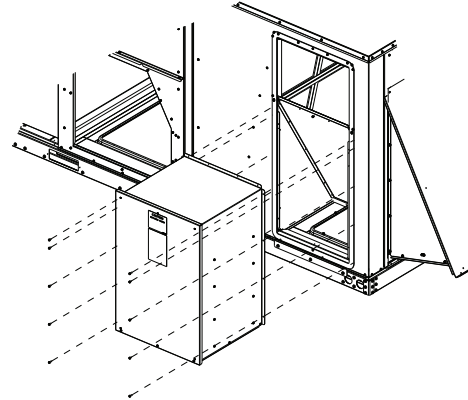

9. Using 10 screws, attach horizontal return block-off to unit rear panel.

Figure 23. Attach horizontal return block-off

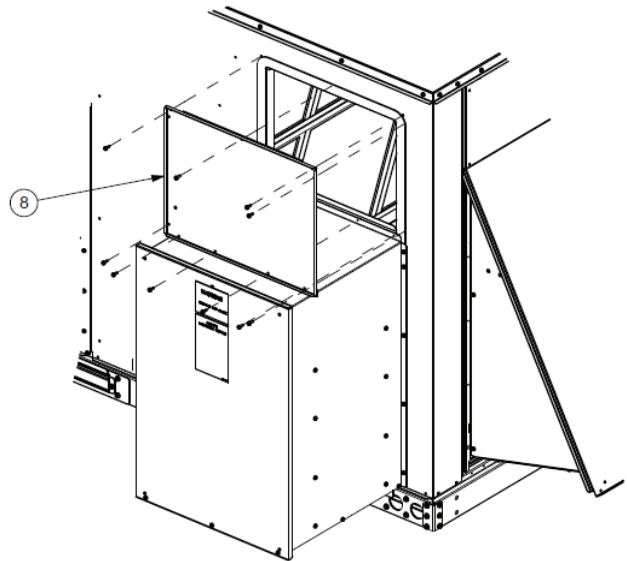

The following are two types of economizers:

10. Standard economizer: Continue to route two power and two control wires (with comparative enthalpy sensor wiring if present) along economizer support channel and secure with four pop-in wire ties. See [Figure 24](#), p. 15.

Figure 24. Route wires along standard economizer support bracket

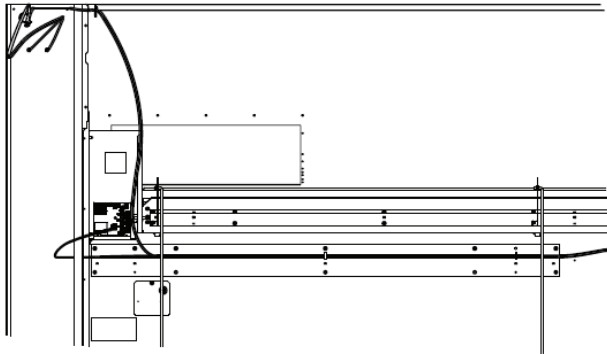

11. Low leak economizer: Route two power and two control wires down the top center block-off panel and secure wires with the four pop-in wire ties that will already be installed across the bottom of the return air damper. See [Figure 25](#).

Figure 25. Route wires along economizer support bracket

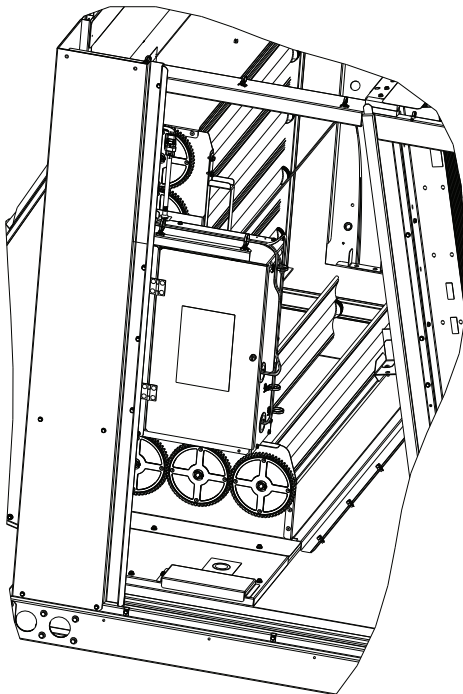

Wiring Installation – FIAPWRX*03*

⚠ WARNING

Hazardous Voltage with Capacitors!

Failure to follow instructions below could result in death or serious injury. Disconnect all electric power, including remote disconnects and wait for DC capacitors to discharge before servicing. Refer to the manufacturer's recommendations for proper discharge time as DC bus capacitors retain hazardous voltages after input power has been disconnected. Follow proper lockout/ tagout procedures to ensure the power cannot be inadvertently energized. Verify with a CAT III or IV voltmeter rated per NFPA 70E that all capacitors have discharged before touching any internal components.

Important: Use provided wire ties to secure and protect wires from sharp edges, rotating parts, and hot surfaces.

Power Wiring

1. See [Figure 26](#), route the high voltage wiring (brown and orange wires) and connector PPF89 (purple connector) along the top of the return control box and down the right side and enter enclosure through bottom wire hole. Connect PPF89 to PPM89 (purple connector) on the fresh air options module and secure wires with pop-in wire ties.
2. Confirm that all wires are protected from damage by moving parts. Secure the wires with wire ties (provided).
3. After installation is complete, the Symbio™ 700 UC configuration will need to be updated to enable this installed feature.

Figure 26. Power connection to return control box - all units

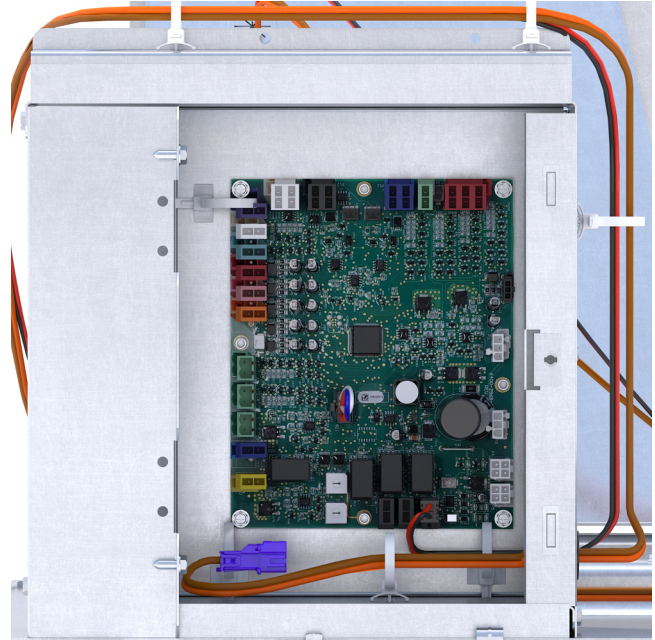

Control Wiring

Units with Standard and Low Leak Economizer

Note: Refer to [Figure 27, p. 17](#) for connections.

Connect power exhaust wire connector J6 to P6 on the fresh air options module in the return control box (brown connector).

1. Route controls wiring (black and red wires) and connector J6 along the top of the return control box and down the right side and enter enclosure through top hole for Precedent B/C/D cabinets or hole towards the back of the enclosure for Precedent A cabinet.
2. Connect wire connector J6 to P6 on the fresh air options module in the return control box (brown connector). Secure wiring with pop-in wire ties. See [Figure 26](#).
3. After installation is complete, the Symbio™ 700 UC configuration will need to be updated to enable this installed feature.

Figure 27. Control wiring diagram

POWER WIRING

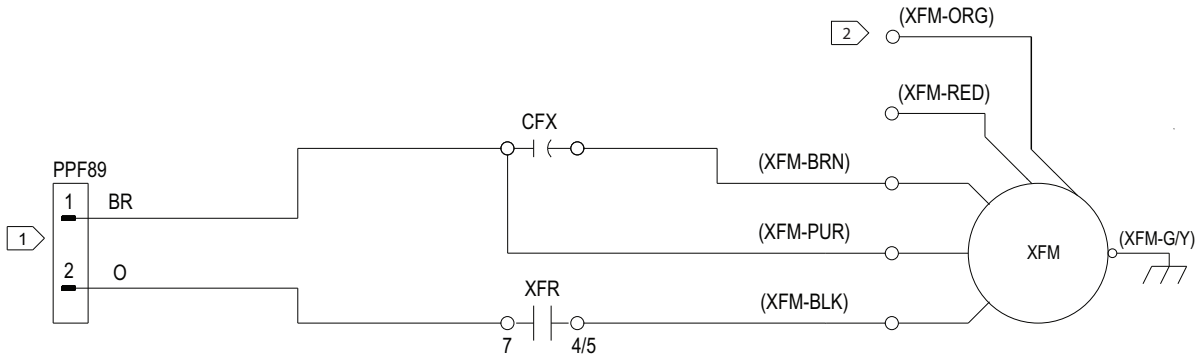

CONTROL WIRING

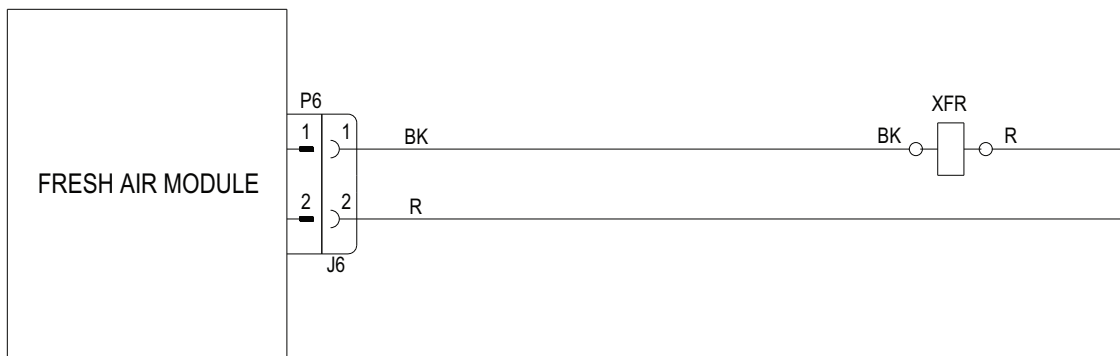

REF	DESCRIPTION
CFX	XFM CAPACITOR
XFM	EXHAUST FAN MOTOR
XFR	EXHAUST FAN RELAY

NOTES:

- 1 MATING CONNECTOR PPM89 IS LOCATED IN THE RETURN ENCLOSURE PANEL
- 2 460V/575V

Power Exhaust Settings with Single Zone VAV and Multi-Speed Units

Set power exhaust setpoint with the fan at maximum speed. Maximum speed can be obtained in full cooling or any heating modes.

Weights and Dimensions

Table 3. Weights and dimensions

Model number	L (inch)	W (inch)	H (inch)	Weight (lbs)
FIAPWRX*02*	20.25	18.25	24.50	80
FIAPWRX*03*	21.50	23.25	34.25	110

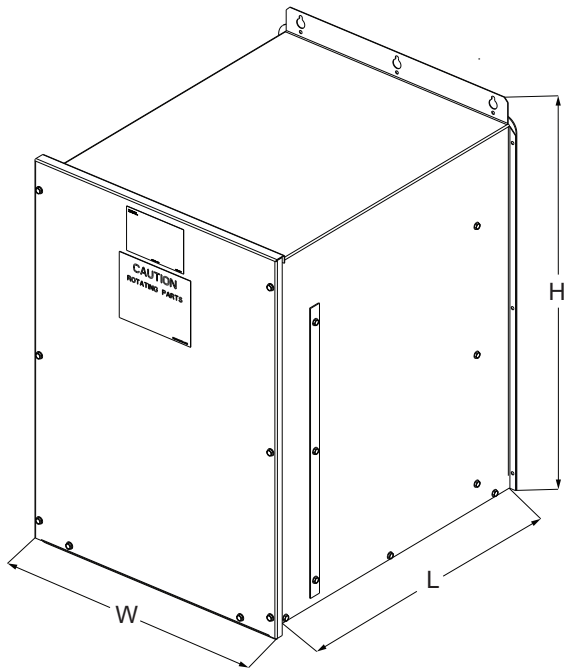

Trane and American Standard create comfortable, energy efficient indoor environments for commercial and residential applications. For more information, please visit trane.com or americanstandardair.com.

Trane and American Standard have a policy of continuous product and product data improvement and reserve the right to change design and specifications without notice. We are committed to using environmentally conscious print practices.