

Installation Instructions

Electric Heaters

Precedent™ Packaged Rooftop Units

3 to 25 Tons

Model Number: Used With:
See General Information

SAFETY WARNING

Only qualified personnel should install and service the equipment. The installation, starting up, and servicing of heating, ventilating, and air-conditioning equipment can be hazardous and requires specific knowledge and training. Improperly installed, adjusted or altered equipment by an unqualified person could result in death or serious injury. When working on the equipment, observe all precautions in the literature and on the tags, stickers, and labels that are attached to the equipment.

September 2024

ACC-SVN228D-EN

Introduction

Read this manual thoroughly before operating or servicing this unit.

Warnings, Cautions, and Notices

Safety advisories appear throughout this manual as required. Your personal safety and the proper operation of this machine depend upon the strict observance of these precautions.

The three types of advisories are defined as follows:

⚠ WARNING Indicates a potentially hazardous situation which, if not avoided, could result in death or serious injury.

⚠ CAUTION Indicates a potentially hazardous situation which, if not avoided, could result in minor or moderate injury. It could also be used to alert against unsafe practices.

NOTICE Indicates a situation that could result in equipment or property–damage only accidents.

Important Environmental Concerns

Scientific research has shown that certain man–made chemicals can affect the earth’s naturally occurring stratospheric ozone layer when released to the atmosphere. In particular, several of the identified chemicals that may affect the ozone layer are refrigerants that contain Chlorine, Fluorine and Carbon (CFCs) and those containing Hydrogen, Chlorine, Fluorine and Carbon (HCFCs). Not all refrigerants containing these compounds have the same potential impact to the environment. Trane advocates the responsible handling of all refrigerants.

Important Responsible Refrigerant Practices

Trane believes that responsible refrigerant practices are important to the environment, our customers, and the air conditioning industry. All technicians who handle refrigerants must be certified according to local rules. For the USA, the Federal Clean Air Act (Section 608) sets forth the requirements for handling, reclaiming, recovering and recycling of certain refrigerants and the equipment that is used in these service procedures. In addition, some states or municipalities may have additional requirements that must also be adhered to for responsible management of refrigerants. Know the applicable laws and follow them.

⚠ WARNING

Proper Field Wiring and Grounding Required!

Failure to follow code could result in death or serious injury. All field wiring **MUST** be performed by qualified personnel. Improperly installed and grounded field wiring poses **FIRE** and **ELECTROCUTION** hazards. To avoid these hazards, you **MUST** follow requirements for field wiring installation and grounding as described in **NEC** and your local/state/national electrical codes.

⚠ WARNING

Personal Protective Equipment (PPE) Required!

Failure to wear proper PPE for the job being undertaken could result in death or serious injury. Technicians, in order to protect themselves from potential electrical, mechanical, and chemical hazards, **MUST** follow precautions in this manual and on the tags, stickers, and labels, as well as the instructions below:

- Before installing/servicing this unit, technicians **MUST** put on all PPE required for the work being undertaken (Examples; cut resistant gloves/sleeves, butyl gloves, safety glasses, hard hat/bump cap, fall protection, electrical PPE and arc flash clothing). **ALWAYS** refer to appropriate Safety Data Sheets (SDS) and OSHA guidelines for proper PPE.
- When working with or around hazardous chemicals, **ALWAYS** refer to the appropriate SDS and OSHA/GHS (Global Harmonized System of Classification and Labeling of Chemicals) guidelines for information on allowable personal exposure levels, proper respiratory protection and handling instructions.
- If there is a risk of energized electrical contact, arc, or flash, technicians **MUST** put on all PPE in accordance with OSHA, NFPA 70E, or other country–specific requirements for arc flash protection, **PRIOR** to servicing the unit. **NEVER PERFORM ANY SWITCHING, DISCONNECTING, OR VOLTAGE TESTING WITHOUT PROPER ELECTRICAL PPE AND ARC FLASH CLOTHING. ENSURE ELECTRICAL METERS AND EQUIPMENT ARE PROPERLY RATED FOR INTENDED VOLTAGE.**

⚠ WARNING

Follow EHS Policies!

Failure to follow instructions below could result in death or serious injury.

- All Trane personnel must follow the company's Environmental, Health and Safety (EHS) policies when performing work such as hot work, electrical, fall protection, lockout/tagout, refrigerant handling, etc. Where local regulations are more stringent than these policies, those regulations supersede these policies.
- Non-Trane personnel should always follow local regulations.

⚠ WARNING

R-454B Flammable A2L Refrigerant!

Failure to use proper equipment or components as described below could result in equipment failure, and possibly fire, which could result in death, serious injury, or equipment damage.

The equipment described in this manual uses R-454B refrigerant which is flammable (A2L). Use ONLY R-454B rated service equipment and components. For specific handling concerns with R-454B, contact your local representative.

Copyright

This document and the information in it are the property of Trane, and may not be used or reproduced in whole or in part without written permission. Trane reserves the right to revise this publication at any time, and to make changes to its content without obligation to notify any person of such revision or change.

Trademarks

All trademarks referenced in this document are the trademarks of their respective owners.

Revision History

- Used with information updated to meet A2L standards.
- Updated tables in General information chapter.
- Revised Installation chapter to add A.0 Cabinet and A2L information.
- Updated Temperature Rise Data table.

Table of Contents

General Information	5
Inspection	5
Installation	9
Precedent A.0 Cabinet	9
Digit 39 = A	9
Precedent B.0/C.0 Cabinet	10
Digit 39 = B/C	10
Precedent D.0/D.1 Cabinet	12
Digit 39 = D	12
Temperature Rise Data	17

General Information

Inspection

1. Unpack all components of the kit.
2. Check carefully for shipping damage. If any damage is found, report it immediately, and file a claim against the transportation company.

Important: Confirm that the available power supply and the unit nameplate comply with the heater nameplate model number being installed.

Notes: Discharge air sensing kit is required for proper simultaneous all heating operation with all heat pump units.

- FIADAST0003 – B0 Cabinet
- FIADAST0005 – C0 Cabinet
- FIADAST0008 – D0/D1 Cabinet

Table 1. Cabinet matrix

Unit Size (Tons)	Model Number Digits 4, 5, 6	Model					
		TSK, YSK	THK, YHK	TZK, YZK	WSK, DSK	WHK, DHK	
3	036	A.0	A.0	B.0	A.0	B.0	
4	048		B.0				B.0
5	060				C.0		C.0
6	072	B.0	B.0	C.0	D.0	D.0	
7.5	090						
8.5	102						
10	120	C.0	D.0	D.1	D.1	D.1	
12.5	150	D.0	D.0				D.0
15	180						D.1
17.5	210	D.0	D.0	D.1	D.1	D.1	
20	240						
25	300						

Table 2. Heaters – 3 to 5 tons

Model Number	Used With		
FIAEHTA306*	T/W/GSK036*3 THK036*3	T/W/GSK048*3	T/W/GSK060*3
FIAEHTA312*			
FIAEHTA318*			
FIAEHTA323*	-	-	
FIAEHTA406*	T/W/GSK036*4 THK036*4	T/W/GSK048*4	T/W/GSK060*4
FIAEHTA412*			
FIAEHTA418*			
FIAEHTA423*	-	-	
FIAEHTAW06*	T/W/GSK036*W THK036*W	T/W/GSK048*W	T/W/GSK060*W
FIAEHTAW12*			
FIAEHTAW18*			
FIAEHTAW23*	-	-	
FIAEHTB306*	TZK036*3	TH/ZK048*3	TH/ZK060*3
FIAEHTB312*			
FIAEHTB318*			
FIAEHTB327*	-	-	

General Information

Table 2. Heaters – 3 to 5 tons (continued)

Model Number	Used With		
FIAEHTB406*	TZK036*4	TH/ZK048*4	TH/ZK060*4
FIAEHTB412*			
FIAEHTB418*			
FIAEHTB427*			
FIAEHTBW06*	TZK036*W	TH/ZK048*W	TH/ZK060*W
FIAEHTBW12*			
FIAEHTBW18*			
FIAEHTBW27*			
FIAEHWB306*	W/GHK036*3	W/GHK048*3	W/GHK060*3
FIAEHWB312*			
FIAEHWB318*			
FIAEHWB327*			
FIAEHWB406*	W/GHK036*4	W/GHK048*4	W/GHK060*4
FIAEHWB412*			
FIAEHWB418*			
FIAEHWB427*			
FIAEHWBW06*	W/GHK036*W	W/GHK048*W	W/GHK060*W
FIAEHWBW12*			
FIAEHWBW18*			
FIAEHWBW27*			

Table 3. Heaters – 6 to 12.5 tons

Model Number	Used With			
FIAEHTB309*	T*J072*3 T*K072*3	T*J090*3 T*K090*3	T*J102*3 T*J102*3	–
FIAEHTB318*				TSJ/K120*3 THK120*3
FIAEHTB327*				
FIAEHTB336*				
FIAEHTB354*	–	–	–	–
FIAEHTC318*	TSJ/K150*3	TZK120*3	–	–
FIAEHTC327*			–	–
FIAEHTC336*			–	–
FIAEHTC354*			–	–
FIAEHTB409*	T*J072*4 T*K072*4	T*J090*4 T*K090*4	T*J102*4 T*K102*4	–
FIAEHTB418*				TSJ/K120*4 THK120*4
FIAEHTB427*				
FIAEHTB436*				
FIAEHTB454*	–	–	–	–
FIAEHTC418*	TSJ/K150*4	TZK120*4	–	–
FIAEHTC427*			–	–
FIAEHTC436*			–	–
FIAEHTC454*			–	–

Table 3. Heaters – 6 to 12.5 tons (continued)

Model Number	Used With			
FIAEHTBW09*	T*J072*W T*K072*W	T*J090*W T*K090*W	T*J102*W T*K102*W	–
FIAEHTBW18*				TSJ/K120*W THK120*W
FIAEHTBW27*				
FIAEHTBW36*				
FIAEHTBW54*	–	–	–	–
FIAEHTCW18*	TSJ/K150*W	TZK120*W	–	–
FIAEHTCW27*			–	–
FIAEHTCW36*			–	–
FIAEHTCW54*			–	–
FIAEHWB309*	W/G*K072*3	W/G*K090*3	W/G*K102*3	–
FIAEHWB318*				–
FIAEHWB327*				–
FIAEHWB336*				–
FIAEHWB354*	–	–	–	–
FIAEHWC318*	W/G*K120*3	–	–	–
FIAEHWC327*		–	–	–
FIAEHWC336*		–	–	–
FIAEHWC354*		–	–	–
FIAEHWB409*	W/G*K072*4	W/G*K090*4	W/G*K102*4	–
FIAEHWB418*				–
FIAEHWB427*				–
FIAEHWB436*				–
FIAEHWB454*	–	–	–	–
FIAEHWC418*	W/G*K120*4	–	–	–
FIAEHWC427*		–	–	–
FIAEHWC436*		–	–	–
FIAEHWC454*		–	–	–
FIAEHWBW09*	W/G*K072*W	W/G*K090*W	W/G*K102*W	–
FIAEHWBW18*				–
FIAEHWBW27*				–
FIAEHWBW36*				–
FIAEHWBW54*	–	–	–	–
FIAEHWCW18*	W/G*K120*W	–	–	–
FIAEHWCW27*		–	–	–
FIAEHWCW36*		–	–	–
FIAEHWCW54*		–	–	–

General Information

Table 4. Heaters – 12.5 to 25 tons

Model Number	Used with				
FIAEHTD318*	THK150*3 TZJ/K150*3	T*J180*3 T*K180*3	–	–	–
FIAEHTD336*			T*J210*3 T*K210*3	T*J240*3 T*K240*3	T*J300*3 T*K300*3
FIAEHTD354*					
FIAEHTD372*	–	–	–	–	–
FIAEHTD418*	THK150*4 TZJ/K150*4	T*J180*4 T*K180*4	–	–	–
FIAEHTD436*			T*J210*4 T*K210*4	T*J240*4 T*K240*4	T*J300*4 T*K300*4
FIAEHTD454*					
FIAEHTD472*	–	–	–	–	–
FIAEHTDW18*	THK150*W TZJ/K150*W	T*J180*W T*K180*W	–	–	–
FIAEHTDW36*			T*J210*W T*K210*W	T*J240*W T*K240*W	T*J300*W T*K300*W
FIAEHTDW54*					
FIAEHTDW72*	–	–	–	–	–
FIAEHWD318*	W/G*J150*3 W/G*K150*3	W/G*J180*3 W/G*K180*3	–	–	–
FIAEHWD336*			W/G*K210*3	W/G*J240*3 W/G*K240*3	W/G*J300*3 W/G*K300*3
FIAEHWD354*					
FIAEHWD372*	–	–	–	–	–
FIAEHWD418*	W/G*J150*4 W/G*K150*4	W/G*J180*4 W/G*K180*4	–	–	–
FIAEHWD436*			W/G*K210*4	W/G*J240*4 W/G*K240*4	W/G*J300*4 W/G*K300*4
FIAEHWD454*					
FIAEHWD472*	–	–	–	–	–
FIAEHWDW18*	W/G*J150*W W/G*K150*W	W/G*J180*W W/G*K180*W	–	–	–
FIAEHWDW36*			W/G*K210*W	W/G*J240*W W/G*K240*W	W/G*J300*W W/G*K300*W
FIAEHWDW54*					
FIAEHWDW72*	–	–	–	–	–

Installation

Precedent A.0 Cabinet

Digit 39 = A

1. Remove heater compartment access panel and unit control box access panel.
2. Remove insulation to expose perimeter of removable panel in the vestibule panel.
3. Clip or cut the retaining tabs around the perimeter of the removable panel.
4. Remove the panel.

Figure 1. A.0 heater

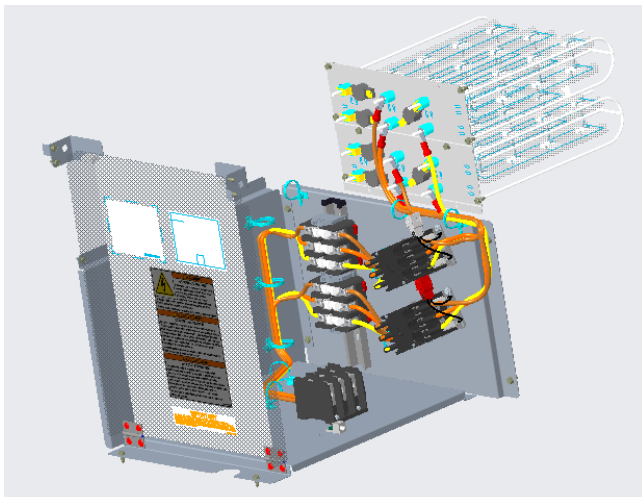

5. Check the opening in the vestibule panel. Remove any metal burrs or slivers that could damage or pinch the heater elements resulting in a short circuit when elements are installed in the opening.
6. The electric heater element assembly has **BOTTOM** stamped in the mounting panel to identify the proper position for mounting.
7. Slide heater assembly along guide rails until heater is fully seated in opening.
8. Secure the electric heater element assembly with the necessary number of screws.
9. Slide the electric heater control panel/access door assembly in until the rear edge engages with retaining clips. Secure the control panel with screws at the top against the vestibule panel and against the indoor divider panel.
10. To install the hinged door stops, loosen one existing screw from the upper left side of the electric heater compartment opening. Position each door stop with outer tab flush against center post and secure each door stop with one or two screws.
11. Wire control voltage harness to Symbio™ 700 using the supplied controls harness.

- a. Route wires from heater assembly to Symbio 700 in main control box. See Figure 2 below for wire routing paths.

Figure 2. Control wiring

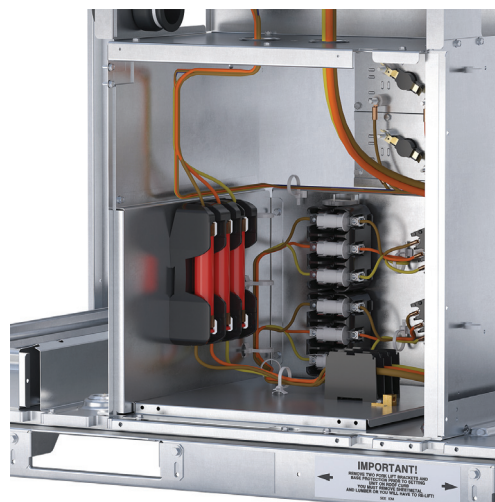
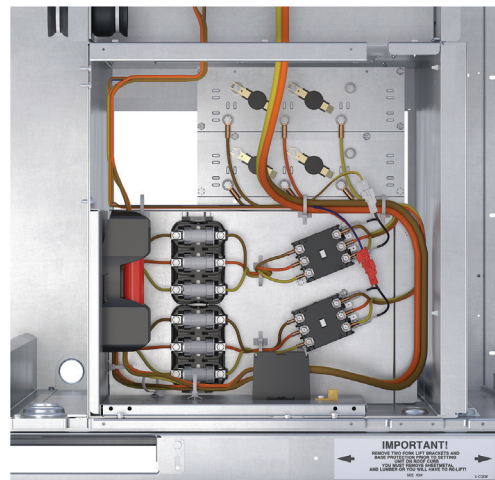
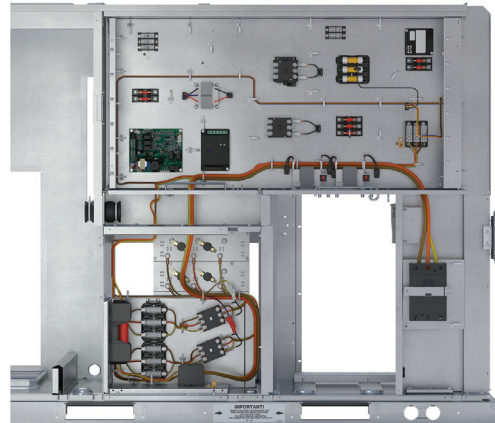

Installation

- b. Connect controls harness to UC-J7.
 - c. Refer to schematic included in this kit and main unit sheet 3 for remaining balance of circuit.
12. After heater is installed and before applying power:
- a. Verify heating elements are not damaged or pinched.
 - b. Verify heating elements are not short circuited to each other or to the heater frame or equipment cabinet.
 - i. Test every heater element with meter and verify heater element terminals are electrically isolated from cabinet and ground (infinite resistance).
 - ii. On downflow units with or without duct work installed or horizontal units without ductwork installed, remove horizontal supply cover and carefully inspect elements after installation for damage or proximity to supporting structure or cabinet. At least 1/4-inch clearance is required around electric heater coils.
 - c. Check tightness of all terminal connections, clamps, screws, etc., as these may have become loose in shipment.
 - d. Tighten all electrical connections after equipment has been in operation and components have reached operating temperature.
13. Install the magnets into the door. The magnets should lock into place once installed.
14. Close electric heater control panel access door, replace heat section access panel, and unit control box access panel.
15. Carefully replace horizontal supply cover. Verify gasketing is not torn or missing. Gasket must make a watertight seal.
16. Scratch out the square on unit nameplate showing heater model installed in unit.

Precedent B.0/C.0 Cabinet

Digit 39 = B/C

⚠ WARNING

Hazardous Voltage w/Capacitors!

Failure to disconnect power and discharge capacitors before servicing could result in death or serious injury. Disconnect all electric power, including remote disconnects and discharge all motor start/run capacitors before servicing. Follow proper lockout/tagout procedures to ensure the power cannot be inadvertently energized. Verify with a CAT III or IV voltmeter rated per NFPA 70E that all capacitors have discharged.

1. Remove heater compartment access panel and unit control box access panel. See [Figure 3](#).

Figure 3. Control covers and access panels

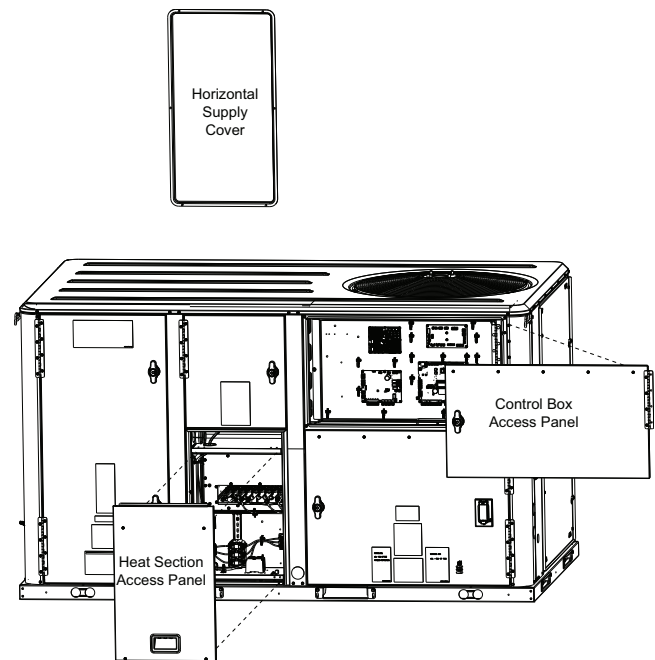

Note: On downflow units with or without duct work installed or horizontal units without ductwork installed, remove horizontal supply cover from the rear of the heater compartment.

2. In the vestibule panel, remove the insulation to expose the perimeter of the removable panel. See [Figure 4](#).
3. Clip the retaining tabs around the perimeter of the removable panel.
4. Remove the panel.

Figure 4. Heater element mounting

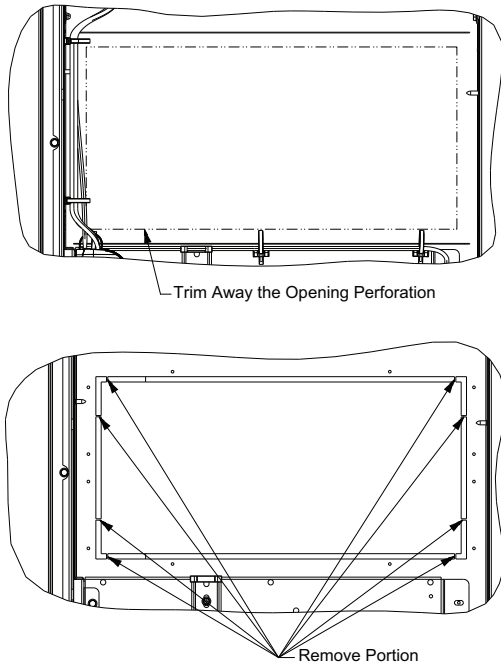

5. Check the opening in the vestibule panel. Remove any metal burrs or slivers that could damage or pinch the heater elements resulting in a short circuit when elements are installed in the opening.
6. The electric heater element assembly has **BOTTOM** stamped in the mounting panel to identify the proper position for mounting.
7. Slide heater assembly along guide rails until heater is fully seated in opening.

Figure 5. Electric heater assembly

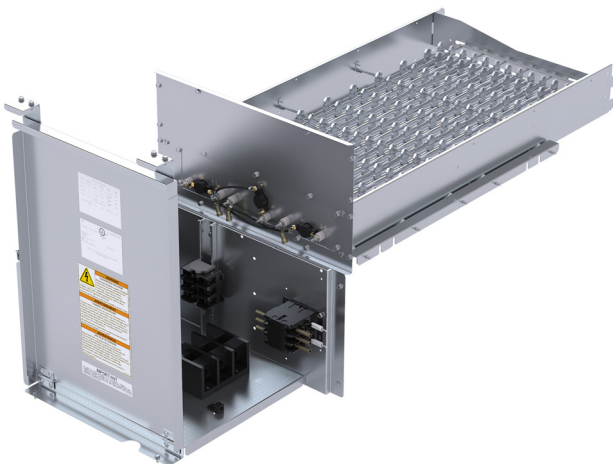

8. Secure the electric heater element assembly with the necessary amount of screws.
9. Remove two screws in base pan of unit.

10. Slide the electric heater control box assembly into unit. Secure with two screws in base (removed in step 9). One screw into divider panel and two screws into electric heat vestibule.

Figure 6. Electric heater control panel/access door assembly

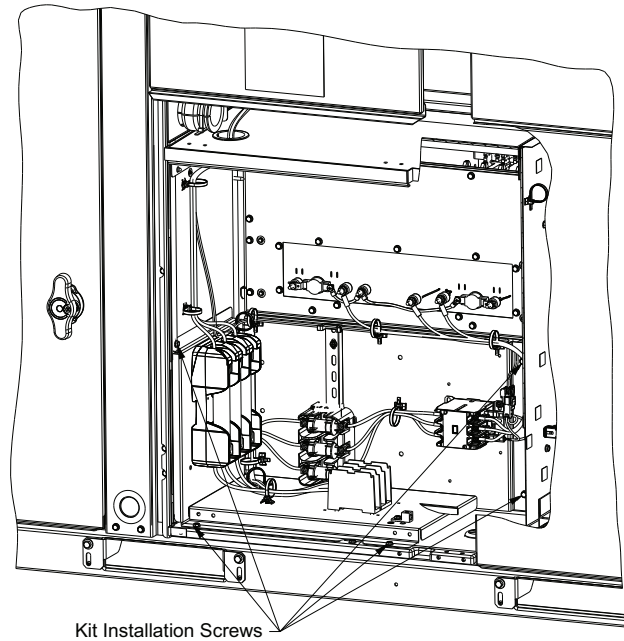

11. To install the hinged door stops, loosen one existing screw from the upper left side of the electric heater compartment opening. Position each door stop with outer tab flush against center post and secure each door stop with one or two screws.

Figure 7. Hinged door stops

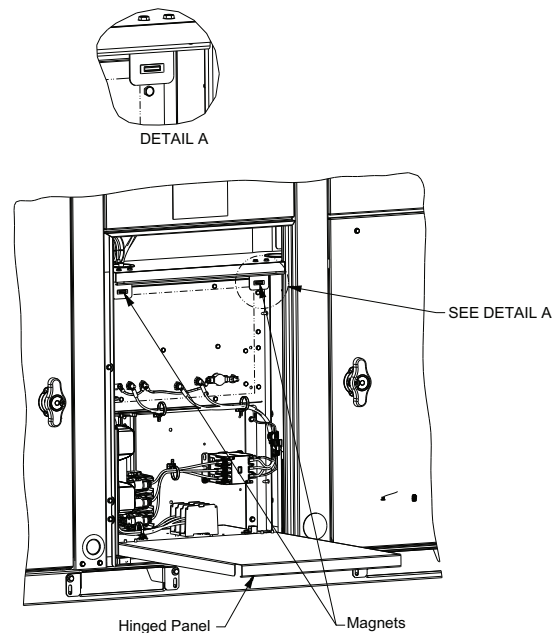

Installation

12. Wire control voltage to indoor options module using the supplied harness. Route wires from heater assembly to indoor options module in main control box. See [Figure 20](#) for indoor option module location. Stage 1 to J6 and stage 2 (if installed) to J7. Refer to included schematic and main unit sheet 5 for remaining balance of circuit.

NOTICE

Use Copper Conductors Only!

Failure to use copper conductors could result in equipment damage as the equipment was not designed or qualified to accept other types of conductors.

⚠ WARNING

Proper Field Wiring and Grounding Required!

Failure to follow code could result in death or serious injury.

All field wiring **MUST** be performed by qualified personnel. Improperly installed and grounded field wiring poses **FIRE** and **ELECTROCUTION** hazards. To avoid these hazards, you **MUST** follow requirements for field wiring installation and grounding as described in **NEC** and your local/state/national electrical codes.

13. After the heater is installed and before applying power, verify the following:
 - a. Heating elements are not damaged or pinched.
 - b. Heating elements are not short circuited to each other or to the heater frame or equipment cabinet.
 - c. Test every heater element with ohmmeter and verify heater element terminals are electrically isolated from cabinet and ground (infinite resistance).
 - i. On downflow units with or without duct work installed or horizontal units without ductwork installed, remove horizontal supply cover and carefully inspect elements after installation for damage or proximity to supporting structure or cabinet.
 - ii. At least 1/4-inch clearance is required around electric heater coils.
 - d. Check tightness of all terminal connections, clamps, screws, etc.
 - e. Tighten all electrical connections after equipment has been in operation and components have reached operating temperature.
14. Install the magnets into the door. The magnets should lock into place once installed.
15. Close electric heater control panel access door, replace heat section access panel, and unit control box access panel.

16. Replace horizontal supply cover. Be careful when replacing cover and verify gasketing is not torn or missing. Gasket must make a water tight seal.
17. Scratch out the square on unit nameplate showing heater model installed in unit.

Precedent D.0/D.1 Cabinet

Digit 39 = D

⚠ WARNING

Hazardous Voltage w/Capacitors!

Failure to disconnect power and discharge capacitors before servicing could result in death or serious injury. Disconnect all electric power, including remote disconnects and discharge all motor start/run capacitors before servicing. Follow proper lockout/tagout procedures to ensure the power cannot be inadvertently energized. Verify with a CAT III or IV voltmeter rated per NFPA 70E that all capacitors have discharged.

NOTICE

Use Copper Conductors Only!

Failure to use copper conductors could result in equipment damage as the equipment was not designed or qualified to accept other types of conductors.

⚠ WARNING

Proper Field Wiring and Grounding Required!

Failure to follow code could result in death or serious injury.

All field wiring **MUST** be performed by qualified personnel. Improperly installed and grounded field wiring poses **FIRE** and **ELECTROCUTION** hazards. To avoid these hazards, you **MUST** follow requirements for field wiring installation and grounding as described in **NEC** and your local/state/national electrical codes.

1. To access the electric heat section, remove the four screws securing the heat section access panel. See [Figure 8](#).

Figure 8. Heat access panel

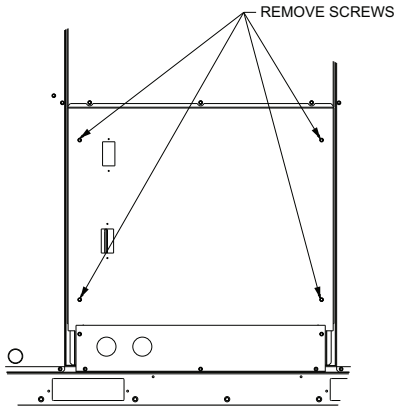

- Remove five screws securing the bottom through-the-base electrical (TBUE) panel. See Figure 9.

Figure 9. Lower TBUE panel

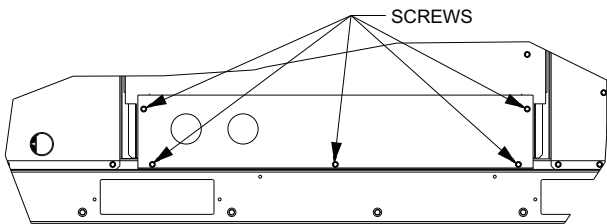

- Remove the bulkhead post by removing screws along the exterior of the post, at the roof, base, and behind the access panel near the top of the unit as shown in Figure 10 below.

Figure 10. Bulkhead post

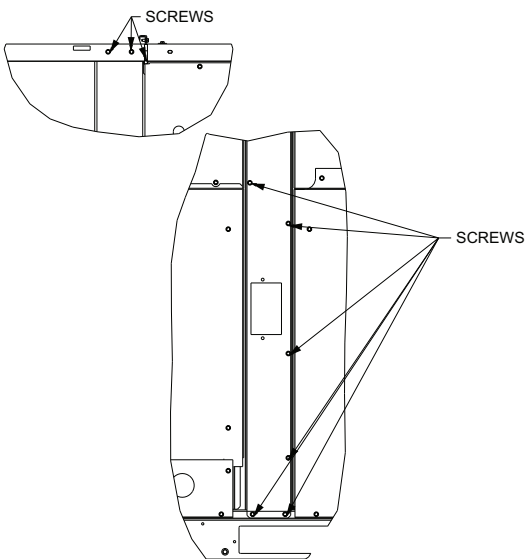

- Once the post is removed, there is clear access to the heat compartment for installation of the FIA electric heater kit.

- Before installing the heater(s) into the unit, complete the following steps:

- Identify the top of each heater element by using the airflow direction label on the terminal plate. When oriented correctly, the airflow arrow will point down. Refer to the Table 5 for heater identification based on overall kit kW.

Table 5. Heater identification

Total Heater kW	Heater 1 kW	Heater 2 kW
18 kW	18	N/A
36 kW	18	18
54 kW	36	18
72 kW	36	36

- If the heater is a dual heater, adjoin the two heaters end to end with the provided screws in eight locations (four screws on each side). Heater 1 has the faceplate installed.

Note: For W/G 150–300 models: Heater 1 has 140°F/180°F limits and Heater 2 has 150°F/180°F limits installed.

Figure 11. Dual heater connection

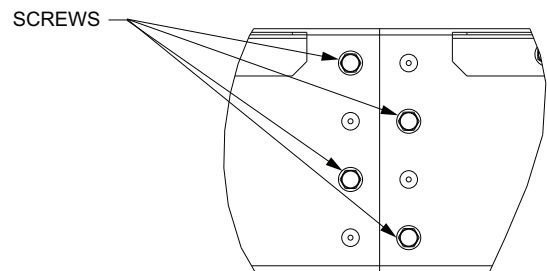

- For a dual heater, install the ring bushing into the faceplate. For a single heater, install the plastic cap.

Dual Heaters Only:

- To install the wire chase, place the wire harness next to the heaters that were just assembled. The wire chase is in two pieces.
- Route the Heater 2 wires through the bushing and run the wires to Heater 2. Heater 2 wires are labeled 2A or 2B.
- Install the other plastic ring bushing in the wire chase hole so it is installed from the inside out to allow access to the wire tie.

Installation

Figure 12. Rear wire chase connection

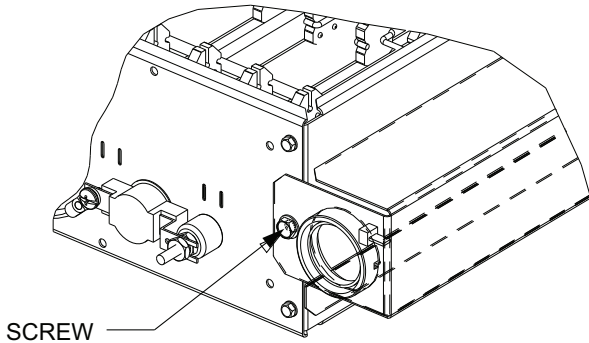

6. Attach the two piece wire chase together using two screws.

Figure 13. Wire chase assembly

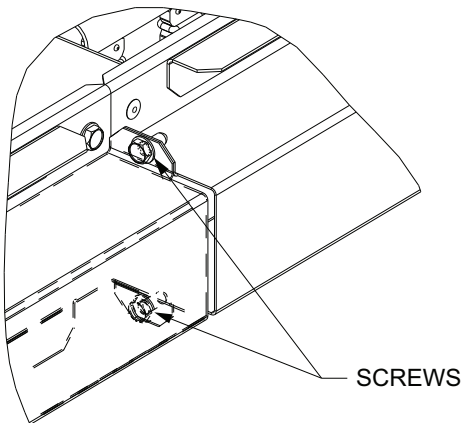

7. Attach the wire chase to the heater assembly. Verify the wire harness is inside the wire chase and not trapped between the chase and heater side channels. This step will require:

- Two screws to the terminal plate.
- One screw in the center on the bottom of the wire chase.
- One screw on the back heater.

Figure 14. Wire chase connection

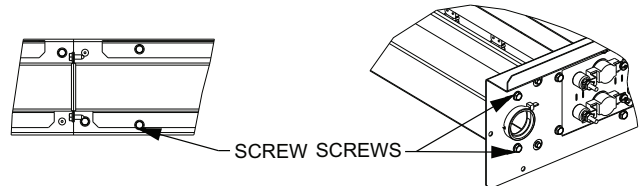

8. Connect the wire harness to the correct terminals on Heater 2 (reference the wiring schematic on the hinged door inside the kit), and cinch the wire tie on the back wire chase. Verify the wires are not trapped between the heater assembly and the wire chase and cinch the front wire tie at the front bushing.
9. Connect the wire harness to the correct terminals on Heater 1 (reference the wiring schematic on the hinged door inside the kit). The heater assembly is now ready to be installed into the unit.

Important: Torque all terminal connections to 15 to 20 in-lbs.

10. Trim away the heater opening perforation in the insulation to expose the removable portion of the sheet metal.
11. Clip the sheet metal tabs to remove the sheet metal to allow the heater assembly to be installed into the unit.

Figure 15. Heater element mounting

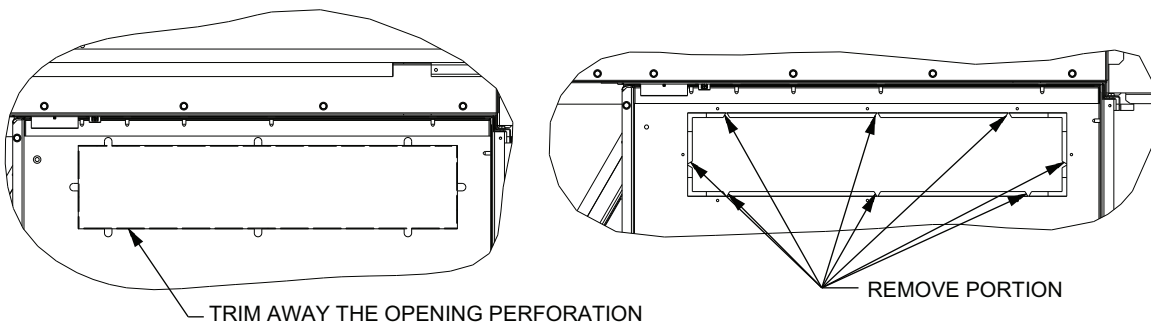

12. Slide the heater assembly into the unit by tipping the back of the assembly up slightly and engaging the heater side brackets between the guide rails. Verify the free end of the wire harness is away from the heater opening as the assembly is guided into place.
13. Secure the heater assembly to the heater vestibule using eight screws.

Figure 16. Heater front panel

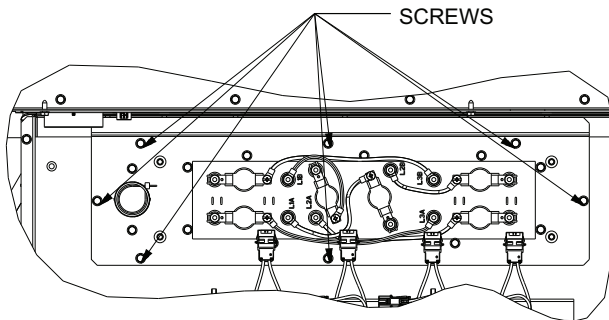

14. Install the magnet bracket in the unit at the top of the heat section with two screws.

Figure 17. Magnet bracket assembly

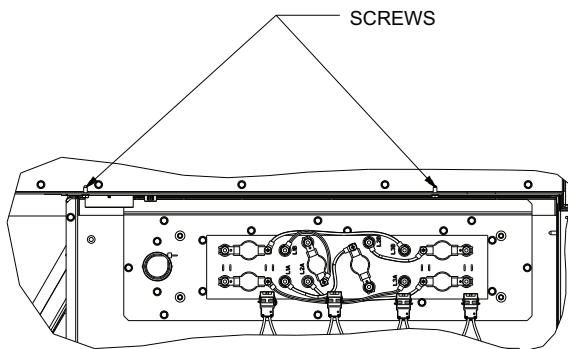

15. Install the heater control panel in the unit using four screws. There are holes in the insulation to assist in locating the screw hole locations.

Figure 18. Electric heat control panel mounting

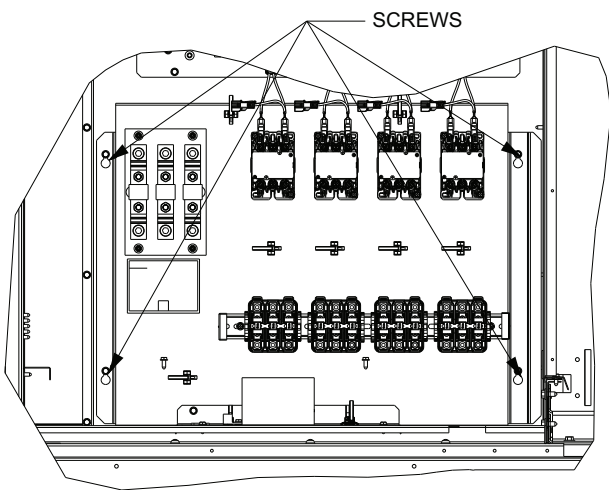

16. Install the heater terminal block plate to the unit base rail and heater control panel.

Figure 19. Terminal plate mounting

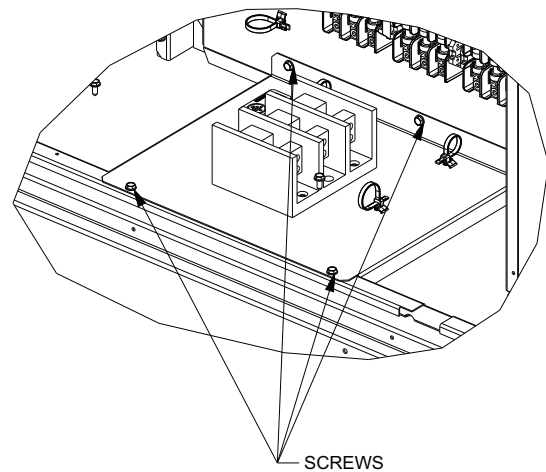

17. Connect the heater element wire harness(es) to the contactors.
18. Connect the wire harness from the terminal block to the bottom side of the heater fuse blocks. Pay close attention to the proper L1/L2/L3 connections for each circuit and wire number (for heater 1A, 1B, 2A or 2B).
19. Connect the wire harness from the terminal block to the main power fuse block.
20. Route wires from Fuse 6–8 (control box fusing) up through top opening in heater directly into closest opening in main control box. Route wire across lower section of main control box to HTB1. Refer to unit level device location sheet for HTB1 location. Be sure pressure lugs on HTB1 are torqued to spec. Refer to label on side of HTB1 for the proper torque based on wire gauge being installed.
21. Connect control harness to connectors on the electric heat contactors and route harness to the main control box.
 - a. Refer to [Figure 20](#) for indoor option module location. Wire control voltage harnesses from contactors to indoor options module. Stage 1 to J6 and Stage 2 (if installed) to J7.
 - b. Refer to schematic for electrical connections. Harness routes out of upper opening in heat assembly then directly into the lower left opening in main control box. Indoor options module is located on left side low voltage door. Route harness through the U-shaped opening located in lower left corner of low voltage door and use wire ties already installed.

Installation

Figure 20. Indoor options access



22. Install the bulkhead post.

23. Install lower TBUE panel to the base.

Figure 21. Lower TBUE panel

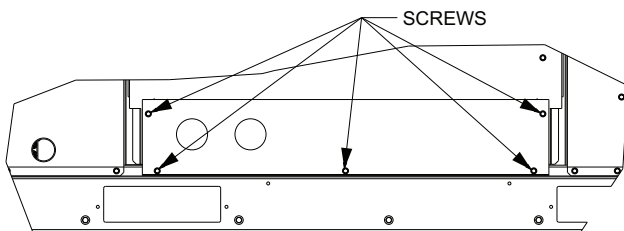

24. Install the heater door assembly. Mount the bracket on the bottom rail with two screws so the schematic labels are on the inside of the door facing the heater control panel and the warning label is facing out.

Figure 22. Hinged access door mounting

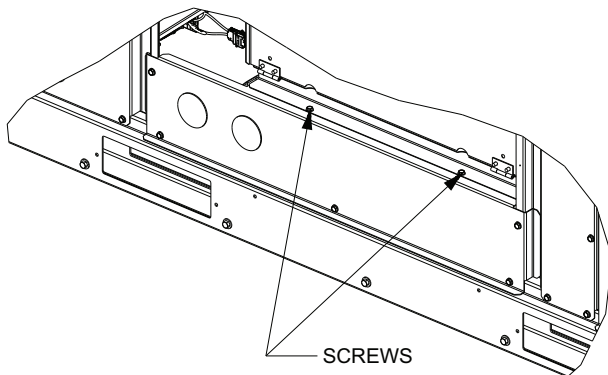

25. Install the four screws that secure the heat section access panel to close access to the electric heat section.

26. Scratch out the square on unit nameplate showing heater model installed in unit.

Temperature Rise Data

Table 6. Air temperature rise^(a)

kW	Stages	3 Tons 900 cfm	4 Tons 1200 cfm	5 Tons 1500 cfm	6 Tons 1800 cfm	7.5 Tons 2250 cfm	8.5 Tons 2550 cfm	10 Tons 3000 cfm	12.5 Tons 3750 cfm	15 Tons 4500 cfm	17.5 Tons 5250 cfm	20 Tons 6000 cfm	25 Tons 7500 cfm
6.00	1	21.07	15.81	12.64	–	–	–	–	–	–	–	–	–
9.00	1	–	–	–	15.81	12.64	11.16	–	–	–	–	–	–
12.00	2	42.15	31.61	25.29	–	–	–	–	–	–	–	–	–
18.00	1 ^(b)	63.22	47.42	37.93	31.61	25.29	22.31	18.97	15.17	12.64	–	–	–
23.00	2	–	–	48.47 ^(c)	–	–	–	–	–	–	–	–	–
27.00	2	–	–	56.90	47.42	37.93	33.47	28.45	22.76	–	–	–	–
36.00	2	–	–	–	63.22	50.58	44.63	37.93	30.35	25.29	21.68	18.97	15.17
54.00	2	–	–	–	–	–	–	56.90	45.52	37.93	32.51	28.45	22.76
72.00	2	–	–	–	–	–	–	–	–	–	43.35	37.93	30.35

(a) For minimum design airflow, see airflow performance table for each unit. To calculate temp rise at different airflow, use the following formula:

$$\text{Temp. rise across Electric Heater} = (\text{kW} \times 3414) / (1.08 \times \text{cfm}).$$

(b) 18kw heater is 2 stages in all B.0 cabinet units.

(c) 23kW heater only applies in 5T standard efficient units.

Notes

Trane and American Standard create comfortable, energy efficient indoor environments for commercial and residential applications. For more information, please visit trane.com or americanstandardair.com.

Trane and American Standard have a policy of continuous product and product data improvement and reserve the right to change design and specifications without notice. We are committed to using environmentally conscious print practices.