

## Installation Guide

# Split System Air Conditioners

## Odyssey™

### MERV 13 Filter Accessory Kits for Odyssey Air Handler – 5 to 25 Tons

**BAYFILT006\***: Used with Odyssey D Cabinet - TWE051, TWE060

**BAYFILT007\***: Used with Odyssey E Cabinet - TWE072, TWE076, TWE090

**BAYFILT008\***: Used with Odyssey F Cabinet - TWE101, TWE120

**BAYFILT009\***: Used with Odyssey G Cabinet - TWE126, TWE150, TWE156, TWE180

**BAYFILT010\***: Used with Odyssey H Cabinet - TWE201, TWE240, TWE251, TWE300

#### SAFETY WARNING

Only qualified personnel should install and service the equipment. The installation, starting up, and servicing of heating, ventilating, and air-conditioning equipment can be hazardous and requires specific knowledge and training. Improperly installed, adjusted or altered equipment by an unqualified person could result in death or serious injury. When working on the equipment, observe all precautions in the literature and on the tags, stickers, and labels that are attached to the equipment.

# Introduction

Read this manual thoroughly before operating or servicing this unit.

## Warnings, Cautions, and Notices

Safety advisories appear throughout this manual as required. Your personal safety and the proper operation of this machine depend upon the strict observance of these precautions.

The three types of advisories are defined as follows:



Indicates a potentially hazardous situation which, if not avoided, could result in death or serious injury.



Indicates a potentially hazardous situation which, if not avoided, could result in minor or moderate injury. It could also be used to alert against unsafe practices.

**NOTICE**

Indicates a situation that could result in equipment or property-damage only accidents.

## Important Environmental Concerns

Scientific research has shown that certain man-made chemicals can affect the earth's naturally occurring stratospheric ozone layer when released to the atmosphere. In particular, several of the identified chemicals that may affect the ozone layer are refrigerants that contain Chlorine, Fluorine and Carbon (CFCs) and those containing Hydrogen, Chlorine, Fluorine and Carbon (HCFCs). Not all refrigerants containing these compounds have the same potential impact to the environment. Trane advocates the responsible handling of all refrigerants.

## Important Responsible Refrigerant Practices

Trane believes that responsible refrigerant practices are important to the environment, our customers, and the air conditioning industry. All technicians who handle refrigerants must be certified according to local rules. For the USA, the Federal Clean Air Act (Section 608) sets forth the requirements for handling, reclaiming, recovering and recycling of certain refrigerants and the equipment that is used in these service procedures. In addition, some states or municipalities may have additional requirements that must also be adhered to for responsible management of refrigerants. Know the applicable laws and follow them.

### **WARNING**

#### **Proper Field Wiring and Grounding Required!**

Failure to follow code could result in death or serious injury.

**All field wiring MUST be performed by qualified personnel. Improperly installed and grounded field wiring poses FIRE and ELECTROCUTION hazards. To avoid these hazards, you MUST follow requirements for field wiring installation and grounding as described in NEC and your local/state/national electrical codes.**

### **WARNING**

#### **Personal Protective Equipment (PPE) Required!**

Failure to wear proper PPE for the job being undertaken could result in death or serious injury.

Technicians, in order to protect themselves from potential electrical, mechanical, and chemical hazards, **MUST** follow precautions in this manual and on the tags, stickers, and labels, as well as the instructions below:

- **Before installing/servicing this unit, technicians MUST put on all PPE required for the work being undertaken (Examples; cut resistant gloves/sleeves, butyl gloves, safety glasses, hard hat/bump cap, fall protection, electrical PPE and arc flash clothing). ALWAYS refer to appropriate Safety Data Sheets (SDS) and OSHA guidelines for proper PPE.**
- **When working with or around hazardous chemicals, ALWAYS refer to the appropriate SDS and OSHA/GHS (Global Harmonized System of Classification and Labelling of Chemicals) guidelines for information on allowable personal exposure levels, proper respiratory protection and handling instructions.**
- **If there is a risk of energized electrical contact, arc, or flash, technicians MUST put on all PPE in accordance with OSHA, NFPA 70E, or other country-specific requirements for arc flash protection, PRIOR to servicing the unit. NEVER PERFORM ANY SWITCHING, DISCONNECTING, OR VOLTAGE TESTING WITHOUT PROPER ELECTRICAL PPE AND ARC FLASH CLOTHING. ENSURE ELECTRICAL METERS AND EQUIPMENT ARE PROPERLY RATED FOR INTENDED VOLTAGE.**

**⚠ WARNING****Follow EHS Policies!**

Failure to follow instructions below could result in death or serious injury.

- All Trane personnel must follow the company's Environmental, Health and Safety (EHS) policies when performing work such as hot work, electrical, fall protection, lockout/tagout, refrigerant handling, etc. Where local regulations are more stringent than these policies, those regulations supersede these policies.
- Non-Trane personnel should always follow local regulations.

**⚠ WARNING****R-454B Flammable A2L Refrigerant!**

Failure to use proper equipment or components as described below could result in equipment failure, and possibly fire, which could result in death, serious injury, or equipment damage.

The equipment described in this manual uses R-454B refrigerant which is flammable (A2L). Use ONLY R-454B rated service equipment and components. For specific handling concerns with R-454B, contact your local representative.

**Copyright**

This document and the information in it are the property of Trane, and may not be used or reproduced in whole or in part without written permission. Trane reserves the right to revise this publication at any time, and to make changes to its content without obligation to notify any person of such revision or change.

**Trademarks**

All trademarks referenced in this document are the trademarks of their respective owners.

**Parts List**

X21130286120 - gasket

Table 1. BAYFILT\* parts list

Cabinet	Model	Used with	Filter Part #	Nominal Size			Qty.	Location	Replace Direction of Filter	Kit Label Part #	
				L	H	D					
D	TWE051, 060	BAYFILT006*	X09011832040	16	20	2	1	SAME LEVEL	LEFT SIDE	436733948600	
			X09011832050	20	20	2	1				
E	TWE072, 076, 090	BAYFILT007*	X09011832010	16	25	2	3		LEFT OR RIGHT SIDE	436733948700	
F	TWE101, 120	BAYFILT008*	X09011832010	16	25	2	4		LEFT OR RIGHT SIDE	436733948800	
G	TWE126, 150, 156, 180	BAYFILT009*	X09011832140	20	15	2	4		UPPER LEVEL	LEFT OR RIGHT SIDE	436733948900
			X09011832140	20	15	2	4		LOWER LEVEL		
H	TWE201, 240, 251, 300	BAYFILT010*	X09011832010	25	16	2	2	UPPER LEVEL	RIGHT SIDE	436733949000	
			X09011832040	20	16	2	2				
			X09011832010	25	16	2	2	LOWER LEVEL			
			X09011832040	20	16	2	2				

# Installation

**Table 2. Static pressure drop through accessories (inch W.G.) — standard air handler**

Tons	Unit Model Number	CFM	2" MERV 13 FILTER
5	TWE060**A/B	1600	0.22
		2000	0.29
		2400	0.36
6	TWE072**B	1920	0.15
		2400	0.19
		2880	0.24
7.5	TWE090**A/B	2400	0.19
		3000	0.25
		3600	0.31
10	TWE120**A/B	3200	0.19
		4000	0.25
		4800	0.31
12.5	TWE150**B	4000	0.15
		5000	0.20
		6000	0.25
15	TWE180**B	4800	0.19
		6000	0.25
		7200	0.31
20	TWE240**B	6400	0.22
		8000	0.29
		9600	0.36
25	TWE300**B	8000	0.29
		1000-0	0.37
		1200-0	0.47

## Installation for 5-10 Ton Air Handlers

1. Refer to parts list for corresponding unit model and correct part number/quantity.
2. Locate kit label and place next to an open spot near the nameplate. See [Figure 1, p. 4](#).
3. From [Figure 1, p. 4](#), loosen the two screws on panel. Set panel aside.

**Figure 1. Panel removal and label location**

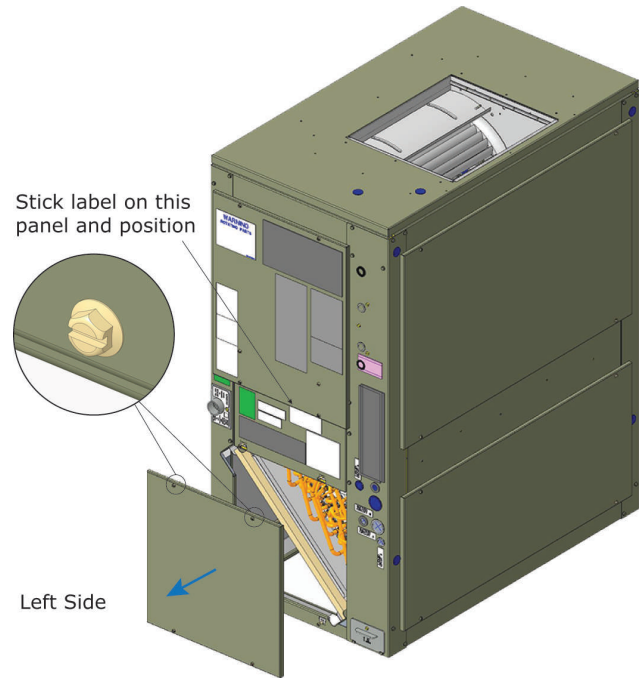

4. Remove original air filters. See [Figure 2, p. 4](#).

**Figure 2. Remove filter**

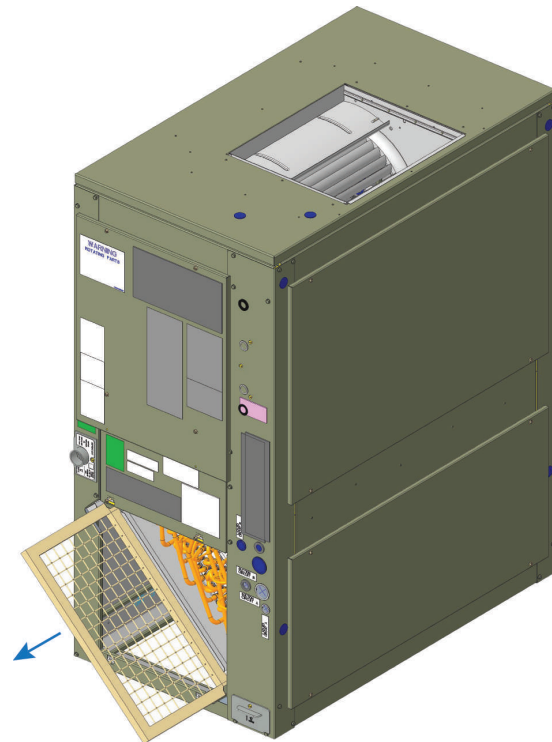

5. Locate two filter racks and loosen four screws on filter rack. [Figure 3, p. 5](#).

**Figure 3. Remove filter rack screws**

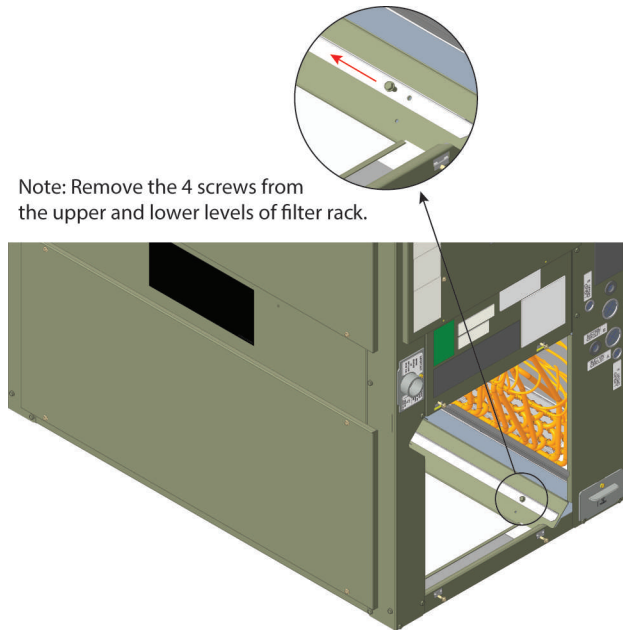

Note: Remove the 4 screws from the upper and lower levels of filter rack.

6. Move filter rack to position shown in [Figure 4, p. 5](#), tighten the four screws.

**Figure 4. Reposition filter rack**

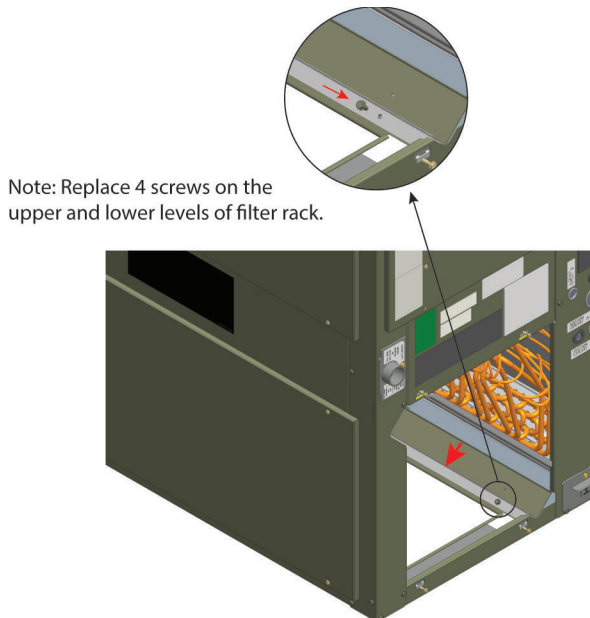

Note: Replace 4 screws on the upper and lower levels of filter rack.

7. Install the new air filter per parts list. Pay attention to length direction of filter and filter rack. See [Figure 5, p. 5](#).

**Figure 5. Install new air filter**

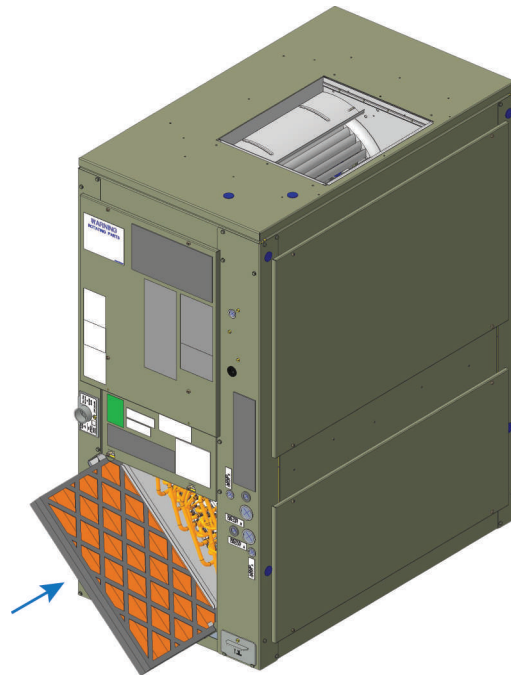

8. Cut the provided gasket to size and paste on the side panel insulation so that it aligns with the location of the filter (for installation in Title 24 compliant regions).

**Figure 6. Add gasket**

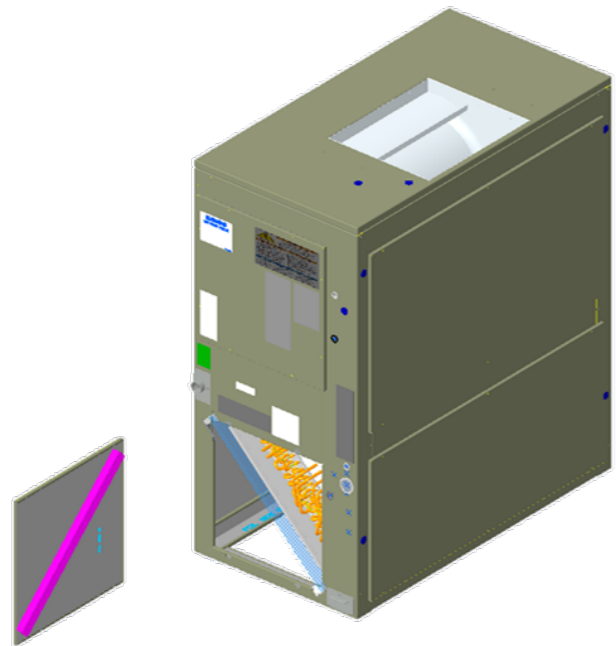

9. Push the filters to the end. Check for gap between filter and newly installed gasket. If there is gap, repeat [Step 7](#) on the side panel on opposite side (for installation in Title 24 compliant regions). See [Figure 7, p. 6](#)

Figure 7. Add gasket on the other side

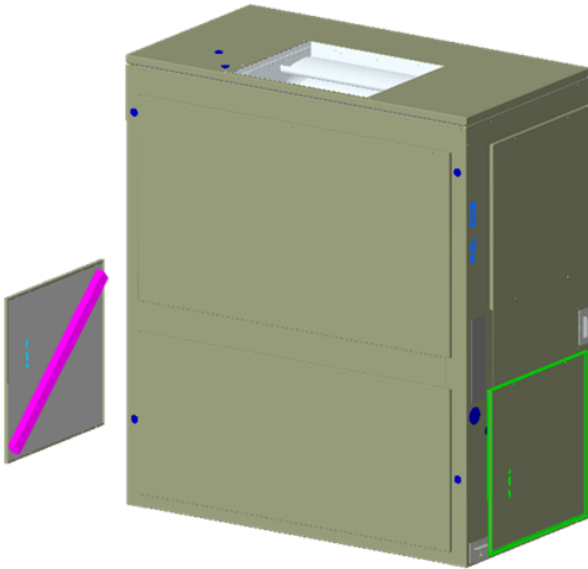

10. Install panel and tighten screws to close the unit. See [Figure 8, p. 6](#).

Figure 8. Panel replacement

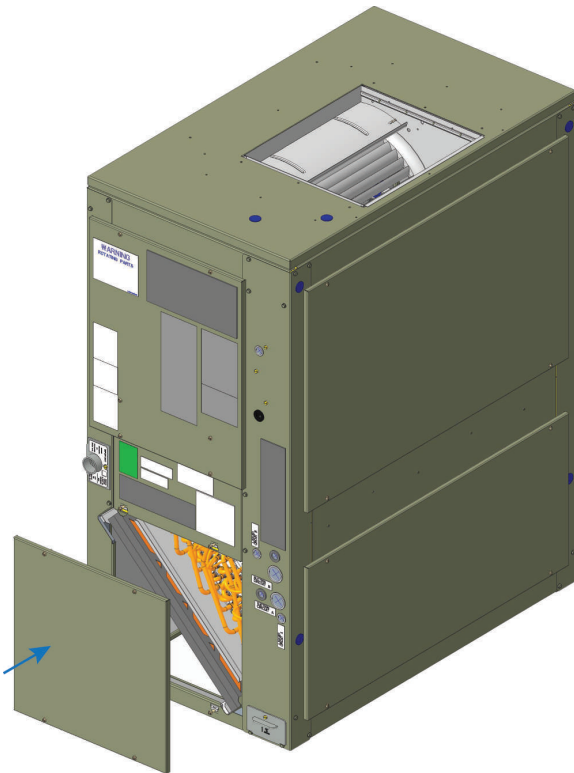

11. Dispose of filter and package.

## Installation for 12.5-25 Ton Air Handlers

1. Refer to parts list for corresponding unit model and correct part number/quantity.
2. Locate kit label and place next to an open spot near the nameplate. See [Figure 9, p. 6](#).

Figure 9. Panel removal and label location

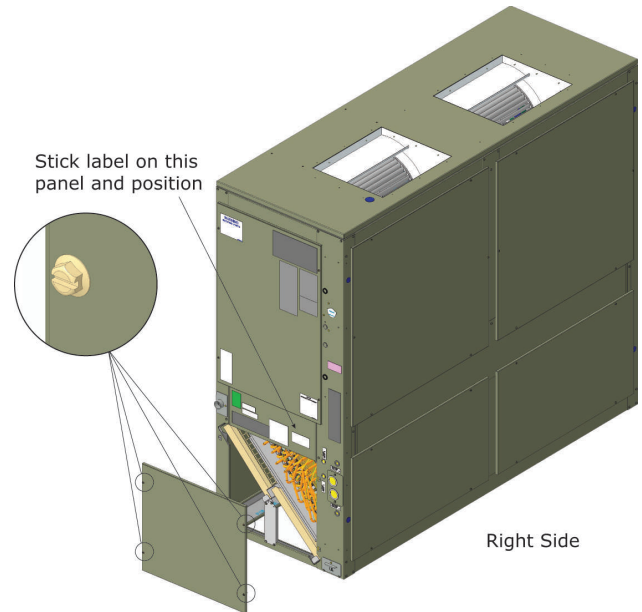

3. From pic shown direction, loosen the four screws on panel. Set panel aside.
4. Remove original air filters. See [Figure 10, p. 7](#).

Figure 10. Filter rack removal

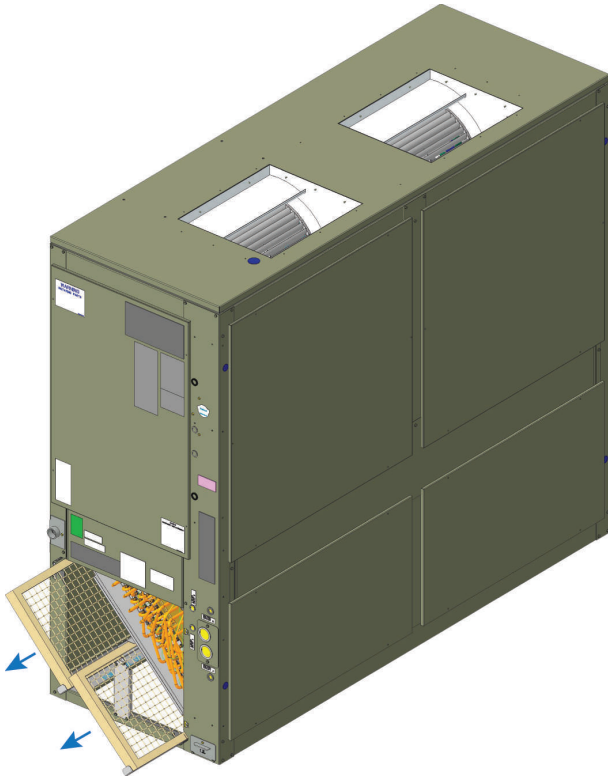

5. Install the new air filter per parts list table.

**Notes:**

- Pay attention to the difference between upper and lower level. See [Figure 11, p. 7](#)
- Pay attention to length direction of filter and filter rack.

Figure 11. Install new filters

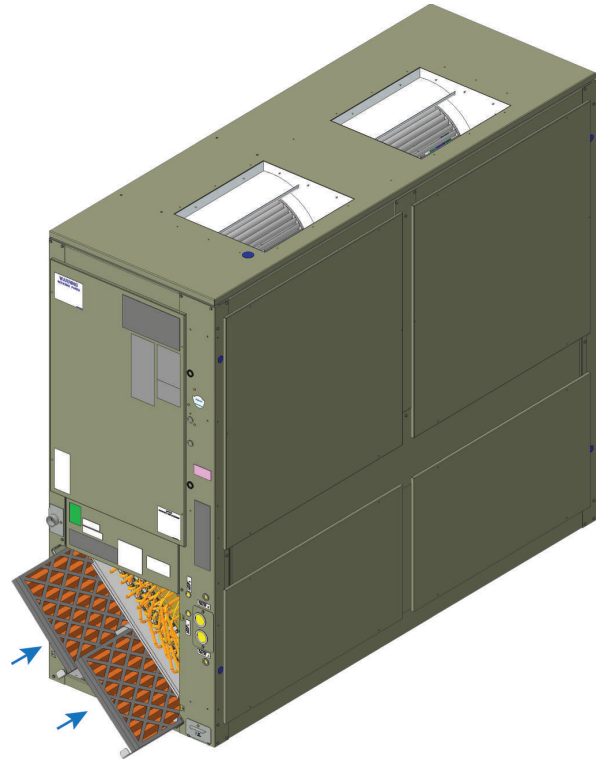

6. Install panel and tighten screws to close the unit. See [Figure 12, p. 7](#).

Figure 12. Install panel

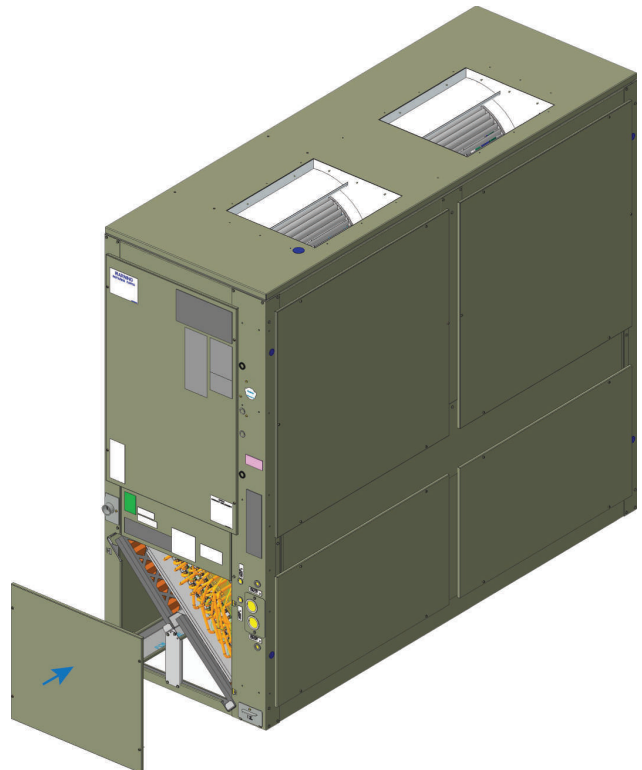

## Installation

---

7. Dispose of filter and package.
8. Cut the provided gasket to size and paste on the side panel insulation so that it aligns with the location of the filter (for installation in Title 24 compliant regions). See [Figure 13, p. 8](#).

**Figure 13. Add gasket**

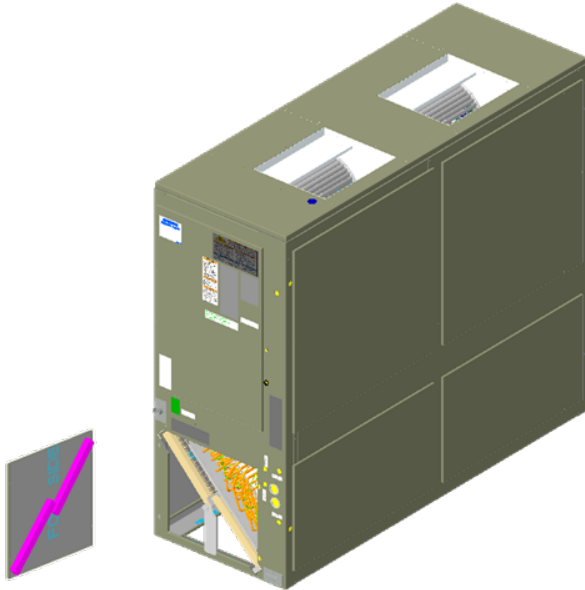

9. Push the filters to the end. Check for gap between filter and newly installed gasket. If there is gap, repeat [Step 8](#) on the side panel on opposite side (for installation in Title 24 compliant regions). See [Figure 14, p. 8](#).

**Figure 14. Add gasket on the other side**

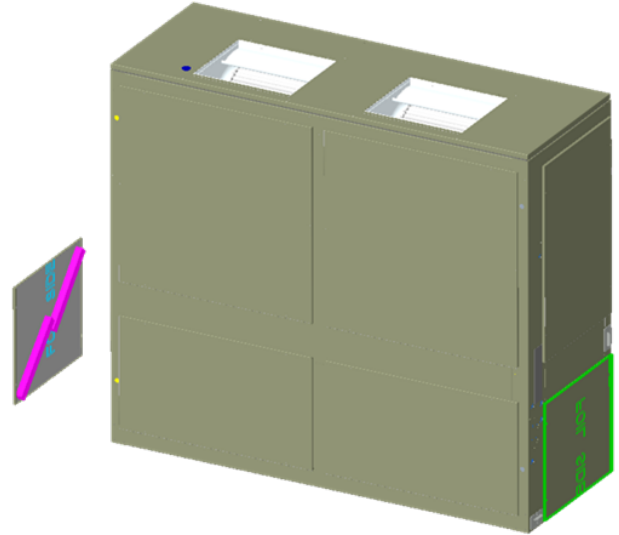









Trane and American Standard create comfortable, energy efficient indoor environments for commercial and residential applications. For more information, please visit [trane.com](http://trane.com) or [americanstandardair.com](http://americanstandardair.com).

Trane and American Standard have a policy of continuous product and product data improvement and reserve the right to change design and specifications without notice. We are committed to using environmentally conscious print practices.

ACC-SVN218C-EN 11 Aug 2024  
Supersedes ACC-SVN218B-EN (April 2020)

©2024