

Installation Instructions

Horizontal and Downflow Standard Economizer

Foundation™ Packaged Rooftop Units
3 to 5 Tons

Model Number:
BAYECON320*

Used With:
E/GB*036-060
E/GD*036-060

SAFETY WARNING

Only qualified personnel should install and service the equipment. The installation, starting up, and servicing of heating, ventilating, and air-conditioning equipment can be hazardous and requires specific knowledge and training. Improperly installed, adjusted or altered equipment by an unqualified person could result in death or serious injury. When working on the equipment, observe all precautions in the literature and on the tags, stickers, and labels that are attached to the equipment.

August 2024

ACC-SVN208G-EN

Introduction

Read this manual thoroughly before operating or servicing this unit.

Warnings, Cautions, and Notices

Safety advisories appear throughout this manual as required. Your personal safety and the proper operation of this machine depend upon the strict observance of these precautions.

The three types of advisories are defined as follows:

- ⚠ WARNING** Indicates a potentially hazardous situation which, if not avoided, could result in death or serious injury.
- ⚠ CAUTION** Indicates a potentially hazardous situation which, if not avoided, could result in minor or moderate injury. It could also be used to alert against unsafe practices.
- NOTICE** Indicates a situation that could result in equipment or property-damage only accidents.

Important Environmental Concerns

Scientific research has shown that certain man-made chemicals can affect the earth's naturally occurring stratospheric ozone layer when released to the atmosphere. In particular, several of the identified chemicals that may affect the ozone layer are refrigerants that contain Chlorine, Fluorine and Carbon (CFCs) and those containing Hydrogen, Chlorine, Fluorine and Carbon (HCFCs). Not all refrigerants containing these compounds have the same potential impact to the environment. Trane advocates the responsible handling of all refrigerants.

Important Responsible Refrigerant Practices

Trane believes that responsible refrigerant practices are important to the environment, our customers, and the air conditioning industry. All technicians who handle refrigerants must be certified according to local rules. For the USA, the Federal Clean Air Act (Section 608) sets forth the requirements for handling, reclaiming, recovering and recycling of certain refrigerants and the equipment that is used in these service procedures. In addition, some states or municipalities may have additional requirements that must also be adhered to for responsible management of refrigerants. Know the applicable laws and follow them.

⚠ WARNING

Proper Field Wiring and Grounding Required!

Failure to follow code could result in death or serious injury. All field wiring **MUST** be performed by qualified personnel. Improperly installed and grounded field wiring poses **FIRE** and **ELECTROCUTION** hazards. To avoid these hazards, you **MUST** follow requirements for field wiring installation and grounding as described in **NEC** and your local/state/national electrical codes.

⚠ WARNING

Personal Protective Equipment (PPE) Required!

Failure to wear proper PPE for the job being undertaken could result in death or serious injury. Technicians, in order to protect themselves from potential electrical, mechanical, and chemical hazards, **MUST** follow precautions in this manual and on the tags, stickers, and labels, as well as the instructions below:

- Before installing/servicing this unit, technicians **MUST** put on all PPE required for the work being undertaken (Examples; cut resistant gloves/sleeves, butyl gloves, safety glasses, hard hat/bump cap, fall protection, electrical PPE and arc flash clothing). **ALWAYS** refer to appropriate Safety Data Sheets (SDS) and OSHA guidelines for proper PPE.
- When working with or around hazardous chemicals, **ALWAYS** refer to the appropriate SDS and OSHA/GHS (Global Harmonized System of Classification and Labeling of Chemicals) guidelines for information on allowable personal exposure levels, proper respiratory protection and handling instructions.
- If there is a risk of energized electrical contact, arc, or flash, technicians **MUST** put on all PPE in accordance with OSHA, NFPA 70E, or other country-specific requirements for arc flash protection, **PRIOR** to servicing the unit. **NEVER PERFORM ANY SWITCHING, DISCONNECTING, OR VOLTAGE TESTING WITHOUT PROPER ELECTRICAL PPE AND ARC FLASH CLOTHING. ENSURE ELECTRICAL METERS AND EQUIPMENT ARE PROPERLY RATED FOR INTENDED VOLTAGE.**

⚠ WARNING

Follow EHS Policies!

Failure to follow instructions below could result in death or serious injury.

- All Trane personnel must follow the company's Environmental, Health and Safety (EHS) policies when performing work such as hot work, electrical, fall protection, lockout/tagout, refrigerant handling, etc. Where local regulations are more stringent than these policies, those regulations supersede these policies.
- Non-Trane personnel should always follow local regulations.

⚠ WARNING

R-454B Flammable A2L Refrigerant!

Failure to use proper equipment or components as described below could result in equipment failure, and possibly fire, which could result in death, serious injury, or equipment damage.

The equipment described in this manual uses R-454B refrigerant which is flammable (A2L). Use ONLY R-454B rated service equipment and components. For specific handling concerns with R-454B, contact your local representative.

Copyright

This document and the information in it are the property of Trane, and may not be used or reproduced in whole or in part without written permission. Trane reserves the right to revise this publication at any time, and to make changes to its content without obligation to notify any person of such revision or change.

Trademarks

All trademarks referenced in this document are the trademarks of their respective owners.

Table of Contents

General Information	5
Inspection	5
Parts List	5
Field Supplied Part	6
Installation	7
Reconfigure the Damper (Horizontal Configuration Only)	7
Install Optional Sensors	7
Install Duct Block-off Plate	7
Economizer Installation	8
Install Mixed Air Sensor	9
Factory Installed Economizer Set-Up	10
Downflow Configuration	10
Horizontal Configuration	11
Mist eliminator servicing	11
Minimum Position Setting	12
Dry Bulb Settings	12
Reference Enthalpy Settings	12

General Information

Inspection

1. Check carefully for shipping damage. If any damage is found, report it immediately, and file a claim against the transportation company. Replace damaged parts with authorized parts only.

2. Compare the order number on the shipping label with the accessory identification information on the ordering and shipping documents to verify that the correct accessory has been received.

Figure 1. Economizer components

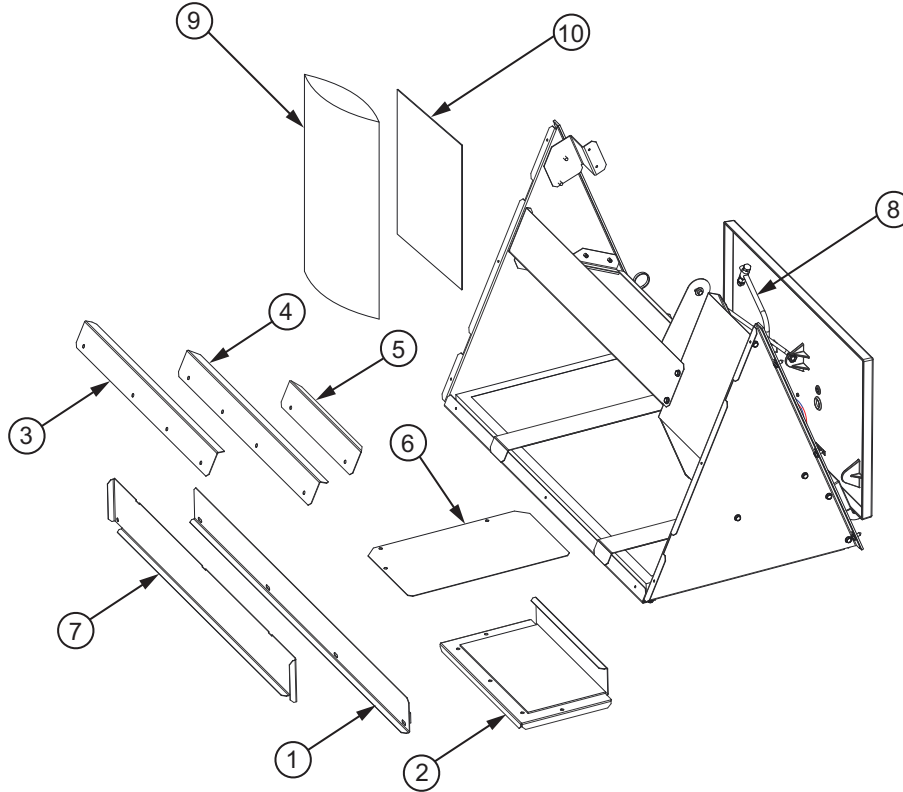

Parts List

Each economizer ships partially assembled. The steps for installation are illustrated throughout this guide. Refer to the figures as the steps are performed. Figure 1, p. 5 illustrates the major components of the economizer when shipped for field installation. Uncrate the economizer and check for the following parts.

Table 1. Economizer component parts list

Item	Description	Qty
1	Rain block-off	1
2	Duct block-off	1
3	Horizontal return air bracket	1
4	Horizontal return air bracket	1
5	Horizontal return air bracket	1
6	Duct block-off	1
7	Duct block-off	1
8	Horizontal linkage rod assembly secured in plastic damper ^(a)	1

Table 1. Economizer component parts list (continued)

Item	Description	Qty
9	Plastic bag of miscellaneous parts:	1
	Screws	—
	Outdoor air temperature sensor	1
	Installation and operation manual	1
	Rubber grommet	1
	Pop-in wire ties	1
10		1
	Economizer assembly (with wire harness)	1
Field supplied parts list		
	Tube Sealant - Trane recommends Sikaflex 221 (SEL00439)	1

(a) For downflow installation, remove this rod from assembly and discard.

Note: Confirm there are no missing parts before starting installation.

General Information

Field Supplied Part

NOTICE

Corrosion Damage!

Failure to use recommended caulking/sealant could cause corrosion related failures to refrigerant components.

Note: While installing and servicing economizer, avoid manual adjustments of damper blade as much as possible. Refer to [Figure 2, p. 6](#). If only required conditions, decouple actuator and shaft connection before manual adjustments of damper blade. Confirm the coupler properly engaged after installation and service. Refer to [Figure 2, p. 6](#).

Figure 2. Economizer damper blade

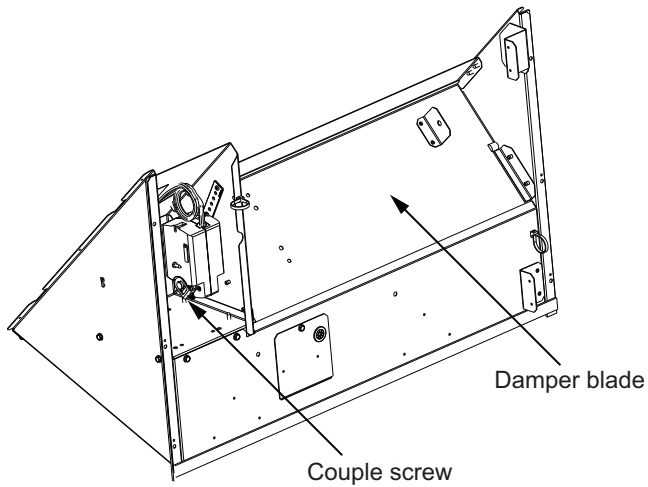

Installation

Reconfigure the Damper (Horizontal Configuration Only)

The economizer damper is shipped from the factory in downflow configuration. Follow steps below to reconfigure it for horizontal installation.

1. Remove two screws from 11. See [Figure 3, p. 7](#).
2. Remove nut and disassemble 12. See [Figure 3, p. 7](#).
3. Remove six screws from 13 (three on each side) and attach to horizontal hinge mounting brackets as shown in [Figure 4, p. 7](#).
4. Connect 8. Do not allow more than 0.25 in. (6.25 mm) of rod to protrude through ball joint at 14.
5. Tape areas shown in [Figure 4, p. 7](#).

Figure 3. Economizer in downflow configuration

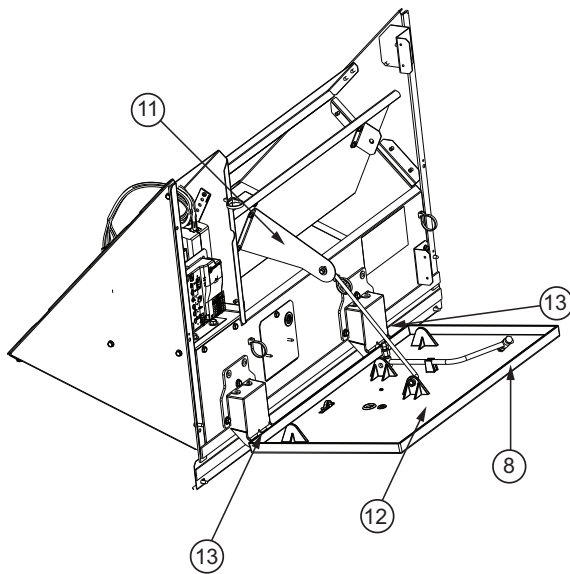
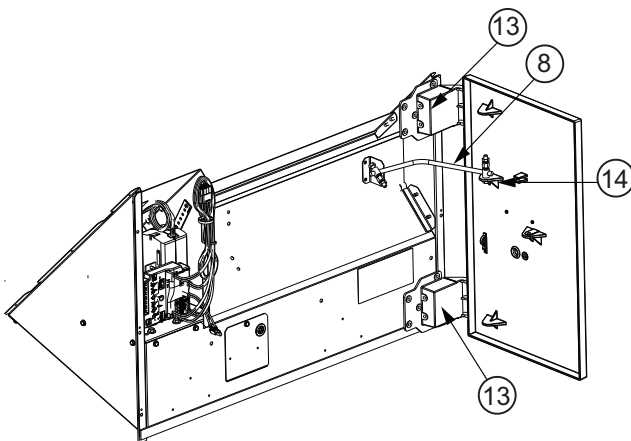

Figure 4. Economizer - horizontal setup



Install Optional Sensors

If optional sensors for humidity and temperature monitoring will be used (BAYENTH320* and BAYENTH321*), install using instructions provided in kits.

Install Duct Block-off Plate

Install duct block-off plate as shown in [Figure 5, p. 7](#) and [Figure 6, p. 7](#).

Important: On downflow units, if power exhaust or barometric relief accessory kits are installed along with an economizer, do not install the duct block-off plate item 6 and 7 shown in [Figure 5, p. 7](#).

Figure 5. Install duct block-off plate - downflow

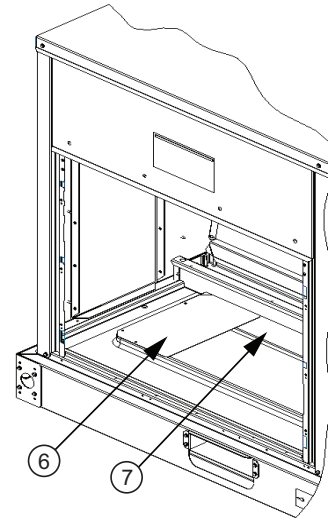
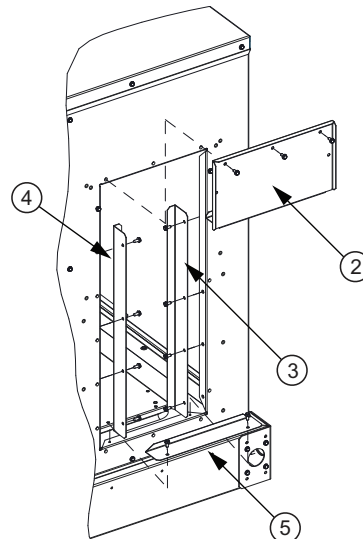

Figure 6. Install duct block-off plate - horizontal



Economizer Installation

⚠ WARNING

Hazardous Service Procedures!

Failure to follow all precautions in this manual and on the tags, stickers, and labels could result in death or serious injury.

Technicians, in order to protect themselves from potential electrical, mechanical, and chemical hazards, **MUST** follow precautions in this manual and on the tags, stickers, and labels, as well as the following instructions: Unless specified otherwise, disconnect all electrical power including remote disconnect and discharge all energy storing devices such as capacitors before servicing. Follow proper lockout/tagout procedures to ensure the power can not be inadvertently energized. When necessary to work with live electrical components, have a qualified licensed electrician or other individual who has been trained in handling live electrical components perform these tasks.

1. Remove unit end panel from the unit.

Figure 7. Remove end panel

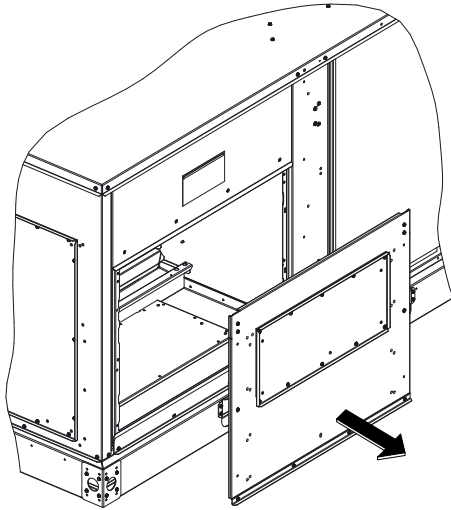

2. Apply gasket on the left hand and right hand posts as shown in [Figure 8, p. 8](#).
3. Remove approximately 3-inch of gasket material from the bottom of each corner post to expose the holes used to attach the economizer assembly to the unit. Make marks on LH and RH post engagement holes (through gasket) for shooting screws during economizer assembly onto unit.

Note: There are 12 holes on LH and RH post for installation; six large clearance holes and six small engagement holes. The following steps will describe how to use them.

Figure 8. Apply gasket

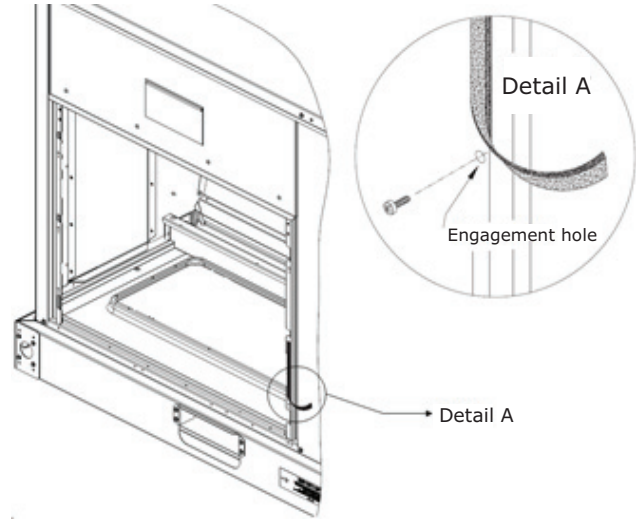

4. Install block-off onto unit base rail as shown in [Figure 9, p. 8](#) using four screws.

Figure 9. Install block-off

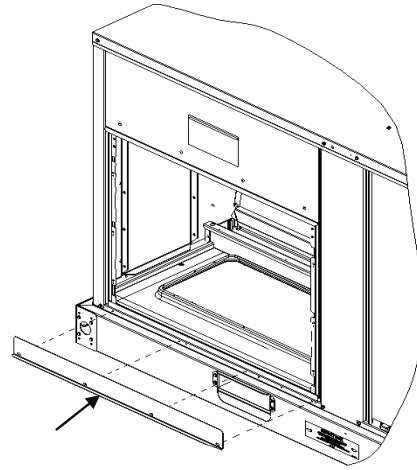

5. Install the economizer assembly onto the unit and secure it by inserting six screws (three on each side) through the clearance holes in the economizer end panel and into the engagement holes on the LH and RH post. Refer to [Figure 10, p. 9](#).

Figure 10. Install economizer

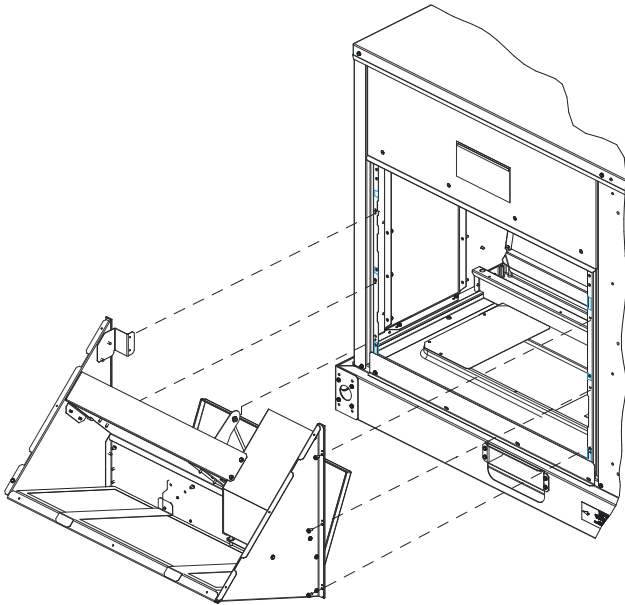

6. Install the end panel onto the economizer assembly. Use four screws at the top, six screws (three on each side) along the sides, and three screws at the bottom. Refer to [Figure 11, p. 9](#) and [Figure 12, p. 9](#).

Figure 11. Reinstall end panel

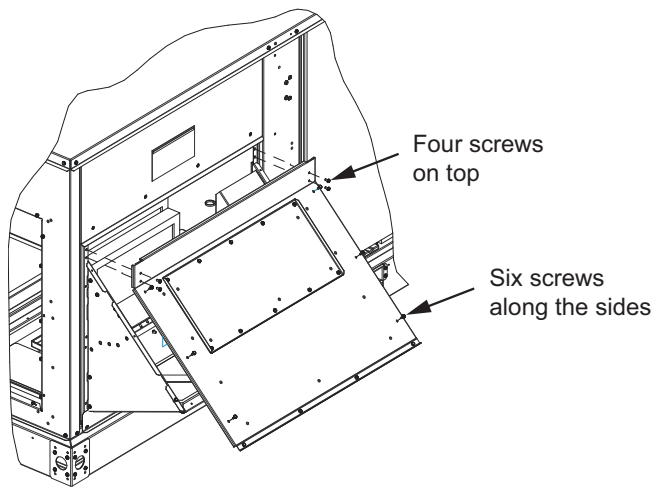
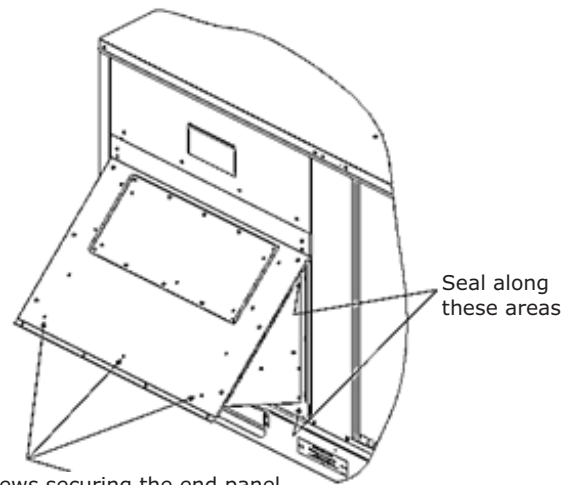

Figure 12. Apply sealant along economizer



3 screws securing the end panel to the economizer frame.

7. Using field supplied silicone, apply sealant around economizer hood.

Install Mixed Air Sensor

1. Install MAS sensor as shown in [Figure 13, p. 9](#) and connect wires 121A and 122A to it.

Figure 13. Install MAS sensor

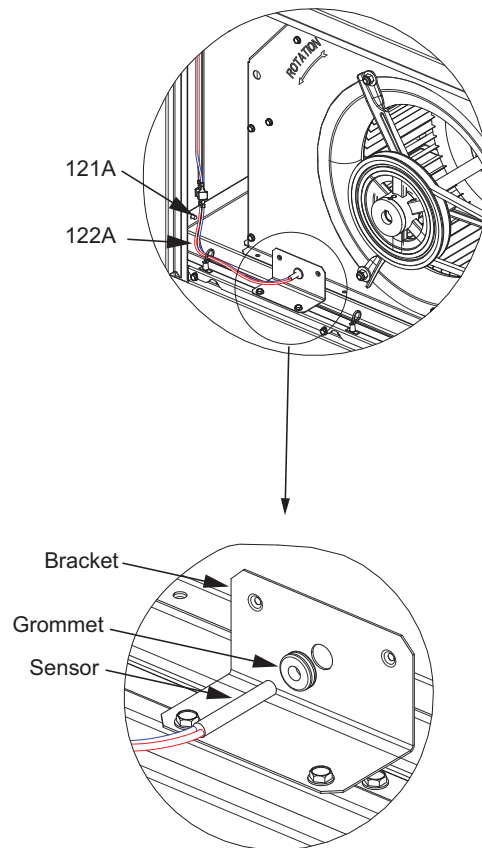

Installation

2. Confirm wires 121A and 122A are connected to MAS terminals on RTEM. See [Figure 14, p. 10](#).

Figure 14. RTEM-MAS

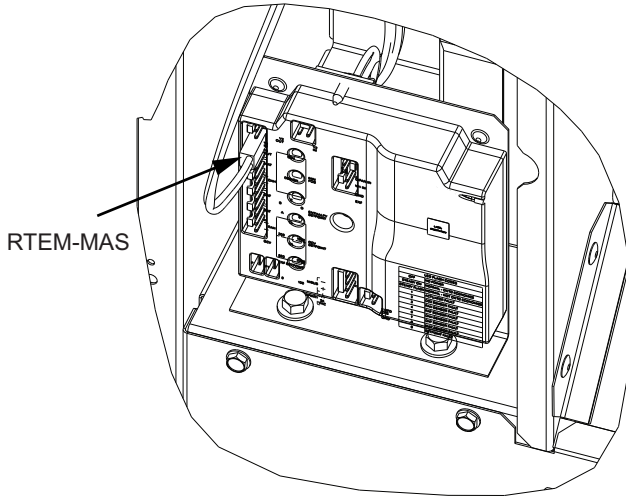

Factory Installed Economizer Setup

This section covers setup of economizer units factory-installed in the unit.

Downflow Configuration

1. Remove horizontal return duct cover.
2. Remove two filters inside the economizer section and set aside for later installation.

Figure 15. Remove parts from indoor section

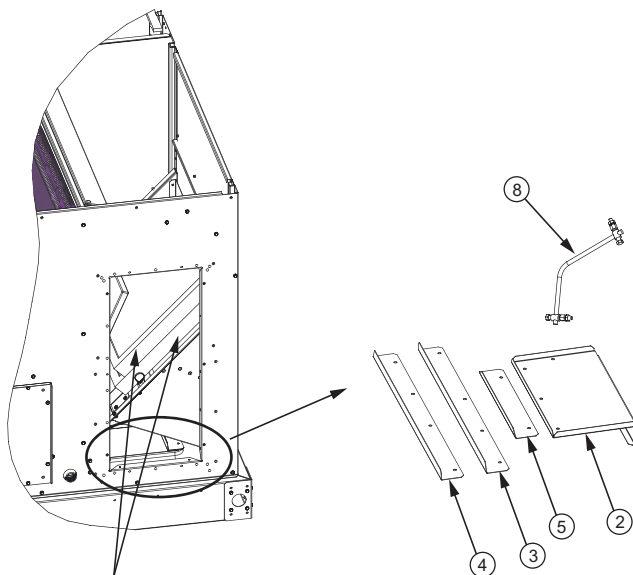

Remove the tape and take filters out for later installation

3. Remove items 2, 3, 4, 5, and 8 from the economizer section as shown in [Figure 15, p. 10](#) and discard. These parts are required only for horizontal economizer configuration.
4. Remove rain block-off out from inside the indoor section.
5. Pull the economizer assembly out into operating position. Using the screws provided, secure each side of the economizer assembly by inserting two screws on each side through the clearance holes in the corner post and into the engagement holes in the economizer assembly.

Figure 16. Pull economizer outward

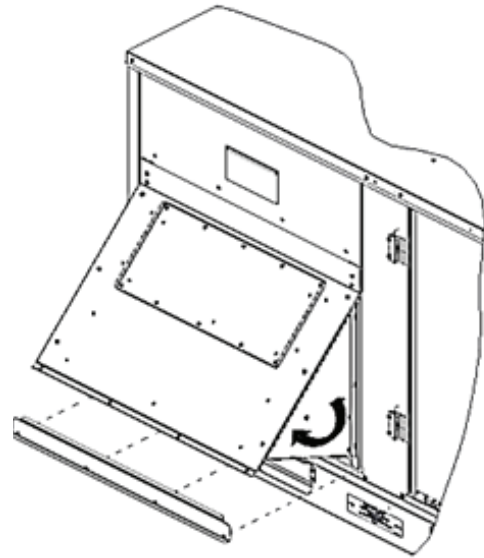

6. Install filters taken out in [Step 2](#) in the bottom filter rack as shown in [Figure 17, p. 10](#).

Figure 17. Install filters

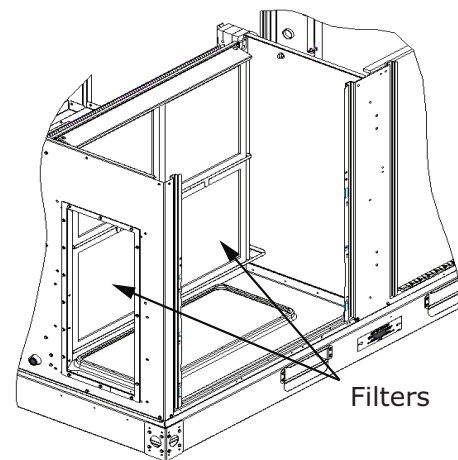

7. Install the block-off angle underneath the economizer. The block off angle is designed to close the opening created between the economizer and the unit base refer [Figure 18, p. 11](#).

Figure 18. Install block-off angle

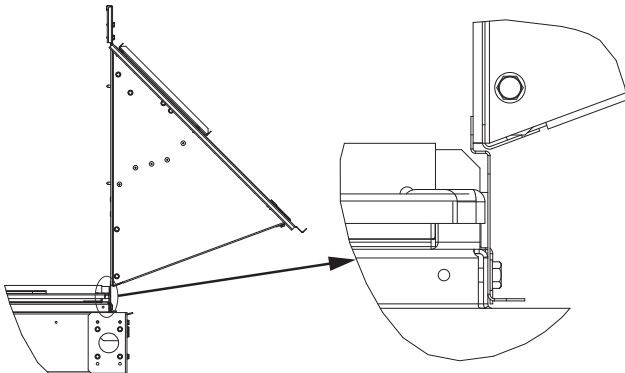

8. Using field supplied silicone, seal around the economizer hood. Refer to [Figure 12, p. 9](#).
9. Reinstall horizontal return duct cover.

Horizontal Configuration

1. Follow [Step 1 to Step 8](#) from “[Downflow Configuration](#),” [p. 10](#).
2. Install the horizontal block-off parts 2, 3, 4, and 5 shown in [Figure 6, p. 7](#).
3. Apply gasket around block-off as shown in [Figure 19, p. 11](#).

Figure 19. Apply gasket

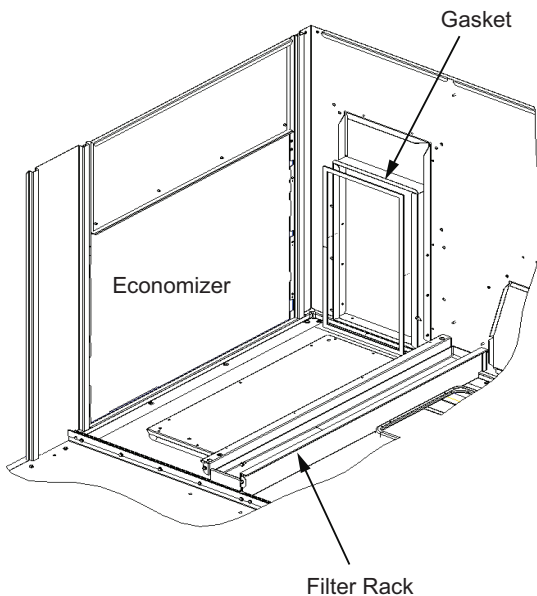

4. Reconfigure the damper for horizontal operation as economizer can not be taken off from unit. See “[Reconfigure the Damper \(Horizontal Configuration Only\)](#),” [p. 7](#) for instructions.

5. If optional sensors for humidity and temperature monitoring are to be used (BAYENTH320* and BAYENTH321*), install them. Use the instructions provided in the kits.
6. Remove return duct cover from the horizontal opening and install over the downflow opening.
7. Using field supplied silicone apply sealant around economizer hood as shown in [Figure 12, p. 9](#).

Mist Eliminator Servicing

1. Remove screws securing end panel to the unit and the economizer and set panel aside.
2. Remove mist eliminator brackets.
3. Remove mist eliminator and clean.
4. Reinstall mist eliminator and secure with brackets.
5. Reinstall end panel and secure it to the unit and the economizer using the screws removed in [Step 1](#).

Figure 20. Mist eliminator servicing

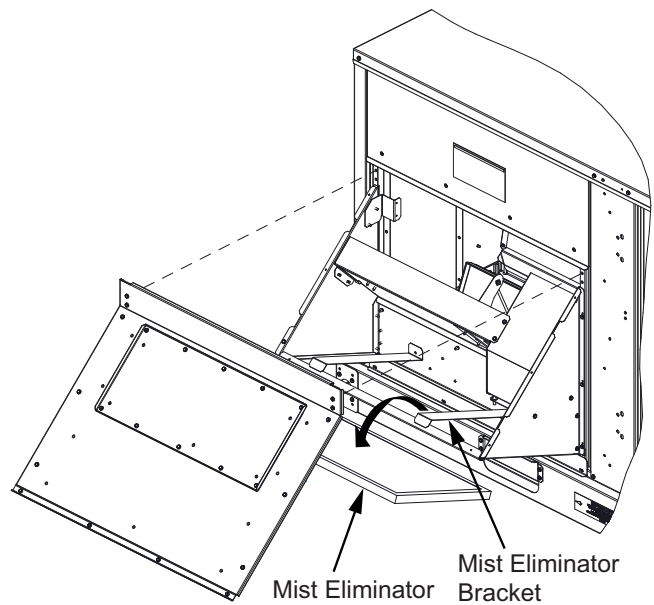

Installation

Minimum Position Setting

To adjust the minimum position setting and check out the economizer, the power must be connected.

1. Close the unit disconnect and place the zone sensor fan selector in the fan **ON** position and the heat/cool selector in the **OFF** position. This will place the damper in the minimum ventilation position.
2. To adjust the minimum position setting for the required ventilation air, turn the potentiometer (on the ECA) clockwise to open (to increase the amount of ventilation) or counterclockwise to close (to decrease the amount of ventilation). The damper will open to this setting each time the blower circuit is energized.

Note: *When adjusting minimum position, the damper may move to the new setting in several small steps. Once the damper has remained in position for 10 to 15 seconds without movement, it can be assumed it is at the new position.*

3. Replace the filter access panel. The damper will close when the blower circuit is de-energized.

Dry Bulb Settings

Standard economizer dry bulb changeover is field selectable to 5 outdoor temperatures. See [Table 2, p. 12](#) for potentiometer settings. The selection is made on the ECA.

Reference Enthalpy Settings

Economizer enthalpy changeover is field selectable to 5 points. See [Table 2, p. 12](#) for potentiometer settings. The selection is made on the ECA.

Table 2. Potentiometer settings

Potentiometer Setting	Dry Bulb	Enthalpy
A	73°F (22.8°C)	27 Btu/lb (63 kJ/kg)
B	70°F (21.1°C)	25 Btu/lb (58 kJ/kg)
C ^(a)	67°F (19.4°C)	23 Btu/lb (53 kJ/kg)
D	63°F (17.2°C)	22 Btu/lb (51 kJ/kg)
E	55°F (12.8°C)	19 Btu/lb (44 KJ/Kg)

(a) Factory setting.

Table 3. Economizer control options

Control Option	Enable Conditions ^(a)	Optional Sensors Required ^(b)
Dry Bulb (standard)	See Table 2, p. 12 .	Outdoor Air Temp. (OAT)
Reference Enthalpy	See Table 2, p. 12 .	Outdoor Humidity (BAYENTH320*)
Comparative Enthalpy	Outdoor Air Enthalpy 3.0 BTU/lb. less than Return Air Enthalpy	Outdoor Humidity Return Humidity Return Temperature

(a) Economizing is enabled when these conditions are met.

(b) Conditions level will be self configured when optional sensors are connected.

Notes

Trane and American Standard create comfortable, energy efficient indoor environments for commercial and residential applications. For more information, please visit trane.com or americanstandardair.com.

Trane and American Standard have a policy of continuous product and product data improvement and reserve the right to change design and specifications without notice. We are committed to using environmentally conscious print practices.