

# Installation Guide

# Head Pressure Control Kit

## Odyssey™ Split System with Symbio™ Controls, 13 to 25 Tons

**BAYLOAMS20:**  
TTA156/180/201/240/251/300  
TWA156/180/201/240

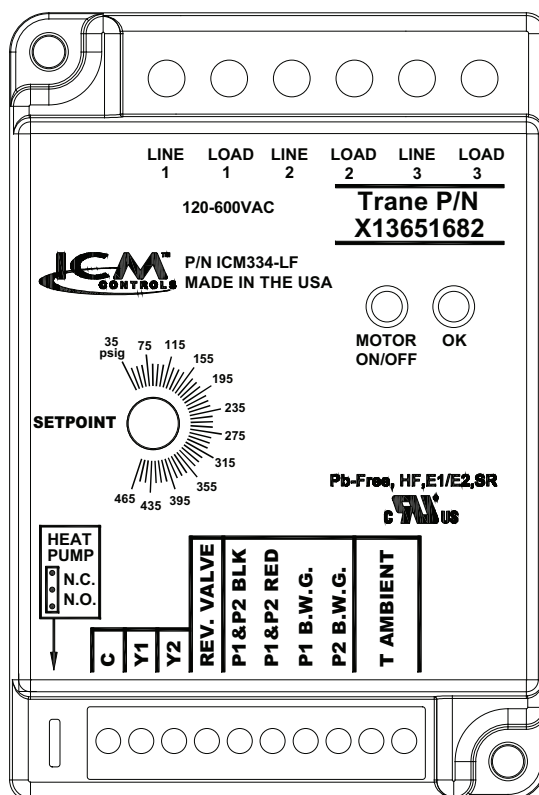

### ⚠ SAFETY WARNING

Only qualified personnel should install and service the equipment. The installation, starting up, and servicing of heating, ventilating, and air-conditioning equipment can be hazardous and requires specific knowledge and training. Improperly installed, adjusted or altered equipment by an unqualified person could result in death or serious injury. When working on the equipment, observe all precautions in the literature and on the tags, stickers, and labels that are attached to the equipment.

# Introduction

Read this manual thoroughly before operating or servicing this unit.

## Warnings, Cautions, and Notices

Safety advisories appear throughout this manual as required. Your personal safety and the proper operation of this machine depend upon the strict observance of these precautions.

The three types of advisories are defined as follows:



Indicates a potentially hazardous situation which, if not avoided, could result in death or serious injury.



Indicates a potentially hazardous situation which, if not avoided, could result in minor or moderate injury. It could also be used to alert against unsafe practices.

**NOTICE**

Indicates a situation that could result in equipment or property-damage only accidents.

## Important Environmental Concerns

Scientific research has shown that certain man-made chemicals can affect the earth's naturally occurring stratospheric ozone layer when released to the atmosphere. In particular, several of the identified chemicals that may affect the ozone layer are refrigerants that contain Chlorine, Fluorine and Carbon (CFCs) and those containing Hydrogen, Chlorine, Fluorine and Carbon (HCFCs). Not all refrigerants containing these compounds have the same potential impact to the environment. Trane advocates the responsible handling of all refrigerants.

## Important Responsible Refrigerant Practices

Trane believes that responsible refrigerant practices are important to the environment, our customers, and the air conditioning industry. All technicians who handle refrigerants must be certified according to local rules. For the USA, the Federal Clean Air Act (Section 608) sets forth the requirements for handling, reclaiming, recovering and recycling of certain refrigerants and the equipment that is used in these service procedures. In addition, some states or municipalities may have additional requirements that must also be adhered to for responsible management of refrigerants. Know the applicable laws and follow them.

### **⚠ WARNING**

#### **Proper Field Wiring and Grounding Required!**

Failure to follow code could result in death or serious injury.

**All field wiring MUST be performed by qualified personnel. Improperly installed and grounded field wiring poses FIRE and ELECTROCUTION hazards. To avoid these hazards, you MUST follow requirements for field wiring installation and grounding as described in NEC and your local/state/national electrical codes.**

### **⚠ WARNING**

#### **Personal Protective Equipment (PPE) Required!**

Failure to wear proper PPE for the job being undertaken could result in death or serious injury.

Technicians, in order to protect themselves from potential electrical, mechanical, and chemical hazards, **MUST follow precautions in this manual and on the tags, stickers, and labels, as well as the instructions below:**

- **Before installing/servicing this unit, technicians MUST put on all PPE required for the work being undertaken (Examples; cut resistant gloves/sleeves, butyl gloves, safety glasses, hard hat/bump cap, fall protection, electrical PPE and arc flash clothing). ALWAYS refer to appropriate Safety Data Sheets (SDS) and OSHA guidelines for proper PPE.**
- **When working with or around hazardous chemicals, ALWAYS refer to the appropriate SDS and OSHA/GHS (Global Harmonized System of Classification and Labelling of Chemicals) guidelines for information on allowable personal exposure levels, proper respiratory protection and handling instructions.**
- **If there is a risk of energized electrical contact, arc, or flash, technicians MUST put on all PPE in accordance with OSHA, NFPA 70E, or other country-specific requirements for arc flash protection, PRIOR to servicing the unit. NEVER PERFORM ANY SWITCHING, DISCONNECTING, OR VOLTAGE TESTING WITHOUT PROPER ELECTRICAL PPE AND ARC FLASH CLOTHING. ENSURE ELECTRICAL METERS AND EQUIPMENT ARE PROPERLY RATED FOR INTENDED VOLTAGE.**

**⚠ WARNING****Follow EHS Policies!**

Failure to follow instructions below could result in death or serious injury.

- All Trane personnel must follow the company's Environmental, Health and Safety (EHS) policies when performing work such as hot work, electrical, fall protection, lockout/tagout, refrigerant handling, etc. Where local regulations are more stringent than these policies, those regulations supersede these policies.
- Non-Trane personnel should always follow local regulations.

**⚠ WARNING****R-454B Flammable A2L Refrigerant!**

Failure to use proper equipment or components as described below could result in equipment failure, and possibly fire, which could result in death, serious injury, or equipment damage.

The equipment described in this manual uses R-454B refrigerant which is flammable (A2L). Use ONLY R-454B rated service equipment and components. For specific handling concerns with R-454B, contact your local representative.

## Copyright

This document and the information in it are the property of Trane, and may not be used or reproduced in whole or in part without written permission. Trane reserves the right to revise this publication at any time, and to make changes to its content without obligation to notify any person of such revision or change.

## Trademarks

All trademarks referenced in this document are the trademarks of their respective owners.

## Revision History

Updates throughout the document to includes the R454-B refrigerant.

# Table of Contents

Pre-Installation .....	5	Transducer and Tee .....	9
Parts List .....	5	Wiring .....	10
General Information .....	6	Control Box Wiring .....	10
Disable Evaporator Defrost Control .....	6	Controller Settings .....	15
Installation .....	7	Operation and Troubleshooting .....	17
Controller .....	7	Checkout Procedure .....	17

# Pre-Installation

## Parts List

Figure 1. Parts list

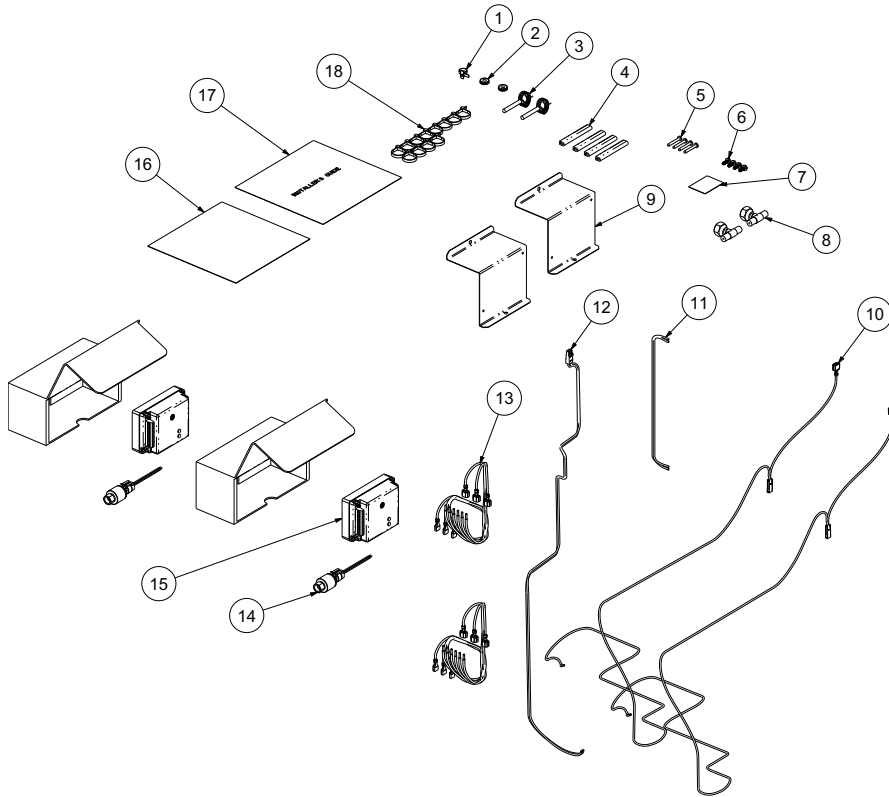

Item Number	Qty	Description
1	1	Pop-in Wire Tie
2	2	Grommet
3	2	Sensor; Thermistor Probe
4	4	Edge Protector
5	4	Screw; # 8-32 X 1.25 Pan Head
6	4	Screw; # 10-16 X .50 Hex Head
7	1	Label; Information BAYLOAMS20
8	2	Tee; Pressure Tap
9	2	Bracket; Support
10	2	Harness; Low Ambient Kit - SOV

Item Number	Qty	Description
11	1	Harness; 2 Kits Jumper
12	1	Harness; 24V UC Board to Loam
13	2	Harness; Power
14	2	Transducer
15	2	Controller; Low Ambient
16	1	Supplemental Wiring Diagram
17	1	Installation Guide
18	12	Wire Tie

## General Information

**Table 1. Low ambient controller specifications**

Volts, AC	208, 240, 380, 415, 480, 600
Control Voltage	18-30 Vac
Frequency	50-60 Hz
Operating Temperature	-40°F to 140°F (-40°C to 60°C)
Full Load Amps	10 Amps
Transducer Pressure Control Range	0-500 psi

## Disable Evaporator Defrost Control

**Important:** For proper operation of the low ambient head pressure control accessory in an Odyssey condenser, the Evaporator Defrost Control (EDC) function **MUST** be disabled.

To disable the EDC, navigate to the "Utilities" menu on the Symbio™ 700 user interface and change the configuration parameter "Evaporator Defrost Control" to "Disabled". The Symbio Service and Installation mobile application can also be used to edit this parameter.

# Installation

## Controller

### ⚠ WARNING

#### Hazardous Voltage w/Capacitors!

Failure to disconnect power and discharge capacitors before servicing could result in death or serious injury.

Disconnect all electric power, including remote disconnects and discharge all motor start/run capacitors before servicing. Follow proper lockout/tagout procedures to ensure the power cannot be inadvertently energized. For variable frequency drives or other energy storing components provided by Trane or others, refer to the appropriate manufacturer's literature for allowable waiting periods for discharge of capacitors. Verify with a CAT III or IV voltmeter rated per NFPA 70E that all capacitors have discharged.

### ⚠ WARNING

#### Proper Field Wiring and Grounding Required!

Failure to follow code could result in death or serious injury.

All field wiring **MUST** be performed by qualified personnel. Improperly installed and grounded field wiring poses **FIRE** and **ELECTROCUTION** hazards. To avoid these hazards, you **MUST** follow requirements for field wiring installation and grounding as described in NEC and your local/state/national electrical codes.

1. Prepare the unit for installation.
  - a. Disconnect and lock out all power from the unit.
  - b. Remove the compressor and control box access panel(s), see [Figure 2, p. 7](#).
2. Remove the Plug screws and install the two brackets with edge protection as shown in [Figure 3, p. 8](#) and [Figure 5, p. 8](#).
3. Mount one controller on each bracket using two 8-32 x 1.25 screws provided. Refer to [Figure 4, p. 8](#).

Figure 2. Removing the compressor and control box access panel

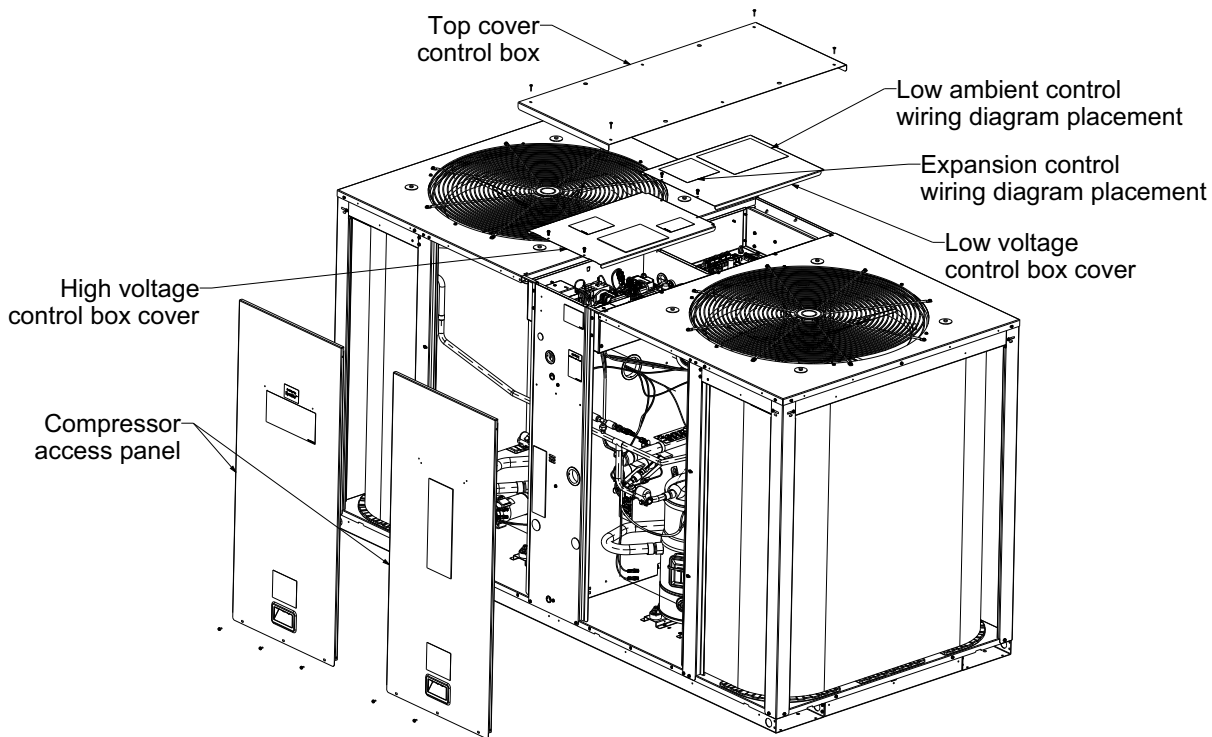

Figure 3. Removing the plug screws

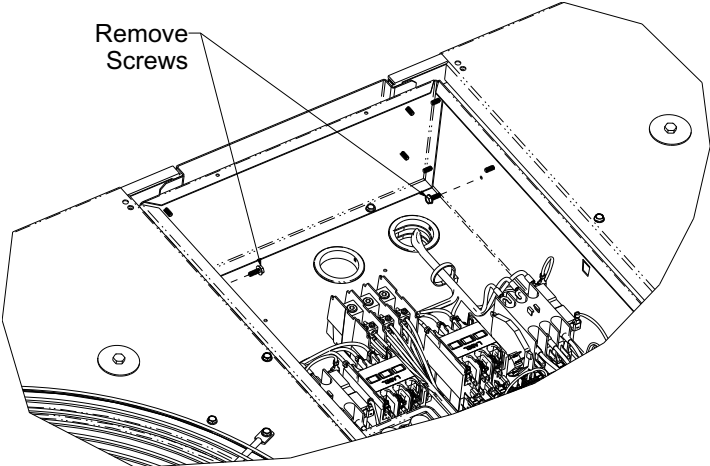

Figure 4. Mounting the controller

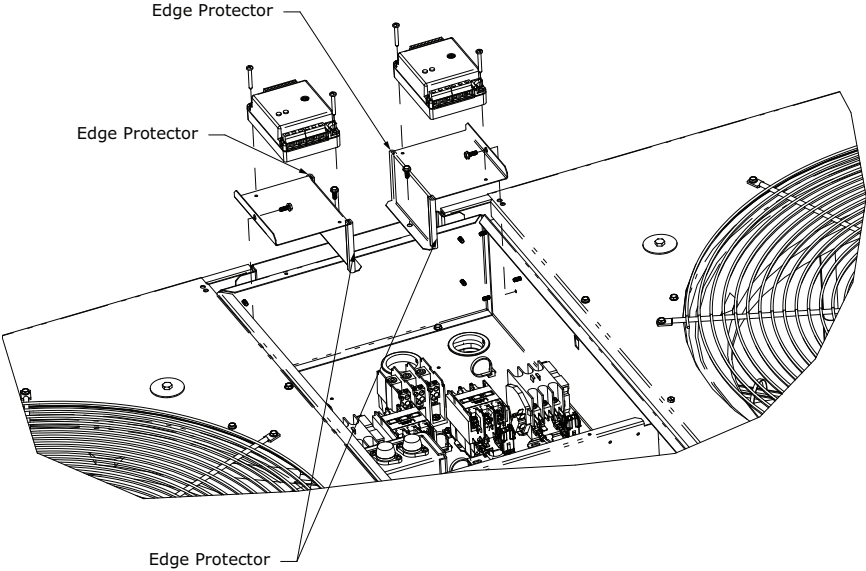
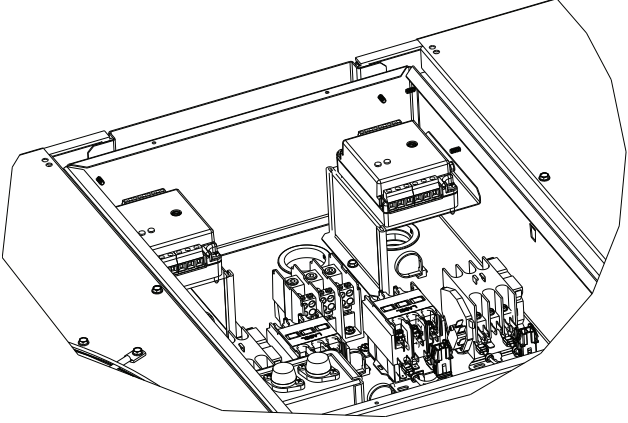

Figure 5. Mounted controller





## Transducer and Tee

### ⚠ WARNING

#### R-410A Refrigerant under Higher Pressure than R-22!

Failure to use proper equipment or components as described below, could result in equipment failing and possibly exploding, which could result in death, serious injury, or equipment damage.

The units described in this manual use R-410A refrigerant which operates at higher pressures than R-22. Use **ONLY R-410A** rated service equipment or components with these units. For specific handling concerns with R-410A, please contact your local Trane representative.

### ⚠ WARNING

#### R-454B Flammable A2L Refrigerant!

Failure to use proper equipment or components as described below could result in equipment failure, and possibly fire, which could result in death, serious injury, or equipment damage.

The equipment described in this manual uses R-454B refrigerant which is flammable (A2L). Use **ONLY R-454B** rated service equipment and components. For specific handling concerns with R-454B, contact your local representative.

### ⚠ WARNING

#### Risk of Fire — Flammable Refrigerant!

Failure to follow instructions below could result in death or serious injury, and equipment damage.

- To be repaired only by trained service personnel.
- Do not puncture refrigerant tubing.
- Dispose of properly in accordance with federal or local regulations.

### NOTICE

#### Wire Damage!

Failure to follow instructions below could result in damaged wires.

Use provided wire ties to make sure wire are secured and protected from sharp edges and hot surfaces.

Install a tee and pressure transducer on the discharge line service port at each compressor using the following instructions:

1. Remove red tags (applicable only for R-454B units) and cap nut from the unit's high pressure service port on the discharge line that runs from the compressor.

Figure 6. High pressure service port

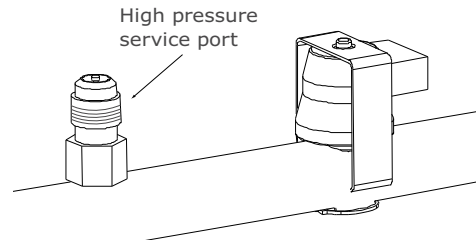

2. Install the transducer onto the Tee port without the valve core.

Figure 7. Transducer to tee

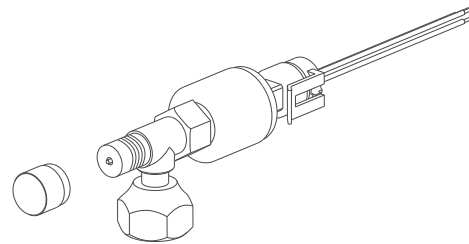

3. Place the Tee flare nut with valve core depressor on the unit high pressure tap, where the cap nut was located.

**Note:** If the high pressure service port is on another Tee, refer to [Figure 8, p. 9](#) for connection.

Figure 8. Tee and transducer installed on high pressure service port

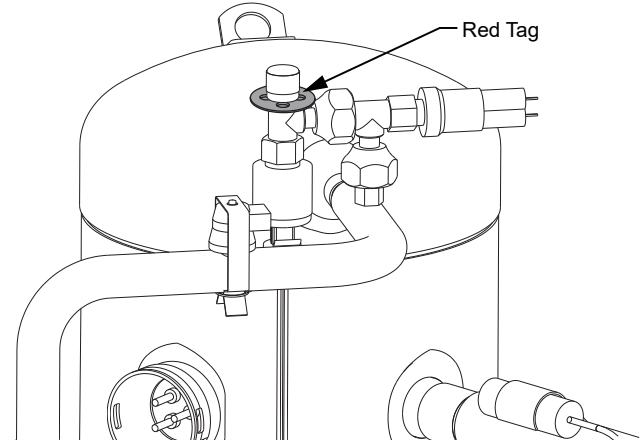

4. For R-454B units, install the red tag in the new service port location before installing the cap nut.
5. Tighten flare nut securely to the high pressure service port and check for leaks.

## Wiring

### NOTICE

#### Wire Damage!

Failure to follow instructions below could result in damaged wires.

Use provided wire ties to make sure wire are secured and protected from sharp edges and hot surfaces.

## Control Box Wiring

### ⚠ WARNING

#### Hazardous Voltage w/Capacitors!

Failure to disconnect power and discharge capacitors before servicing could result in death or serious injury.

Disconnect all electric power, including remote disconnects and discharge all motor start/run capacitors before servicing. Follow proper lockout/tagout procedures to ensure the power cannot be inadvertently energized. For variable frequency drives or other energy storing components provided by Trane or others, refer to the appropriate manufacturer's literature for allowable waiting periods for discharge of capacitors. Verify with a CAT III or IV voltmeter rated per NFPA 70E that all capacitors have discharged.

### ⚠ WARNING

#### Proper Field Wiring and Grounding Required!

Failure to follow code could result in death or serious injury.

All field wiring **MUST** be performed by qualified personnel. Improperly installed and grounded field wiring poses **FIRE** and **ELECTROCUTION** hazards. To avoid these hazards, you **MUST** follow requirements for field wiring installation and grounding as described in NEC and your local/state/national electrical codes.

1. Ensure Unit power has been disconnected and locked out.
2. Disconnect both fan motor harnesses from contactors, install 14 gauge wire harnesses (supplied in kit) between the controller, fan contactors and outdoor fan motor harnesses for both refrigeration circuits. See [Figure 9, p. 11](#).
3. FOR HEAT PUMP UNITS ONLY, connect Switchover valve 1 (SOV1) harness (supplied in kit) using the

following steps:

- a. Disconnect black wire from SOV1. See [Figure 10, p. 12](#).
  - b. Reconnect black wire to black wire in kit harness by making an in-line connection. Securely attach this in-line connection to adjacent wiring with wire ties. See [Figure 11, p. 12](#).
  - c. Connect terminal with black and orange wires to the open tab on SOV1. See [Figure 11, p. 12](#).
  - d. Connect orange wire with stripped end to Rev valve terminal on low amb controller 1. See [Figure 11, p. 12](#).
4. FOR HEAT PUMP UNITS ONLY, connect Switchover valve 2 (SOV2) harness (supplied in kit) using the following steps:
    - a. Disconnect blue wire from SOV2. See [Figure 10, p. 12](#).
    - b. Reconnect blue wire to black wire in kit harness by making an in-line connection. Securely attach this in-line connection to adjacent wiring with wire ties. See [Figure 11, p. 12](#).
    - c. Connect terminal with black and orange wires to the open tab on SOV2. See [Figure 11, p. 12](#).
    - d. Connect orange wire with strip end to Rev valve terminal on low amb controller 2. See [Figure 11, p. 12](#).
  5. Install jumper harness (supplied in kit) between the two controllers. See diagram for reference. See [Figure 12, p. 13](#).
  6. Install 24VAC harness (supplied in kit) between unit controller (UC-P5) and the Low Ambient Controller1. See [Figure 13, p. 13](#).
  7. For each refrigeration circuit install transducer wires to controller as per kit diagram. See [Figure 14, p. 14](#).
  8. For each refrigeration circuit install the thermistors on the outdoor air sensor bracket and connect on controller as per kit diagram. See [Figure 15, p. 15](#).
  9. Finish wiring installation.
    - a. Using wire ties, bundle and dress any excess wires away from sharp edges, moving parts, or hot tubes.
    - b. Apply the diagram (supplied in kit) to an open area on the low voltage access panel. See [Figure 2, p. 7](#) for proper replacement.
    - c. After the settings have been properly adjusted (see ["Controller Settings," p. 15](#)), reinstall the compressor and control box access panels and secure with screws that were removed.

Figure 9. Installing 14 gauge wire harness

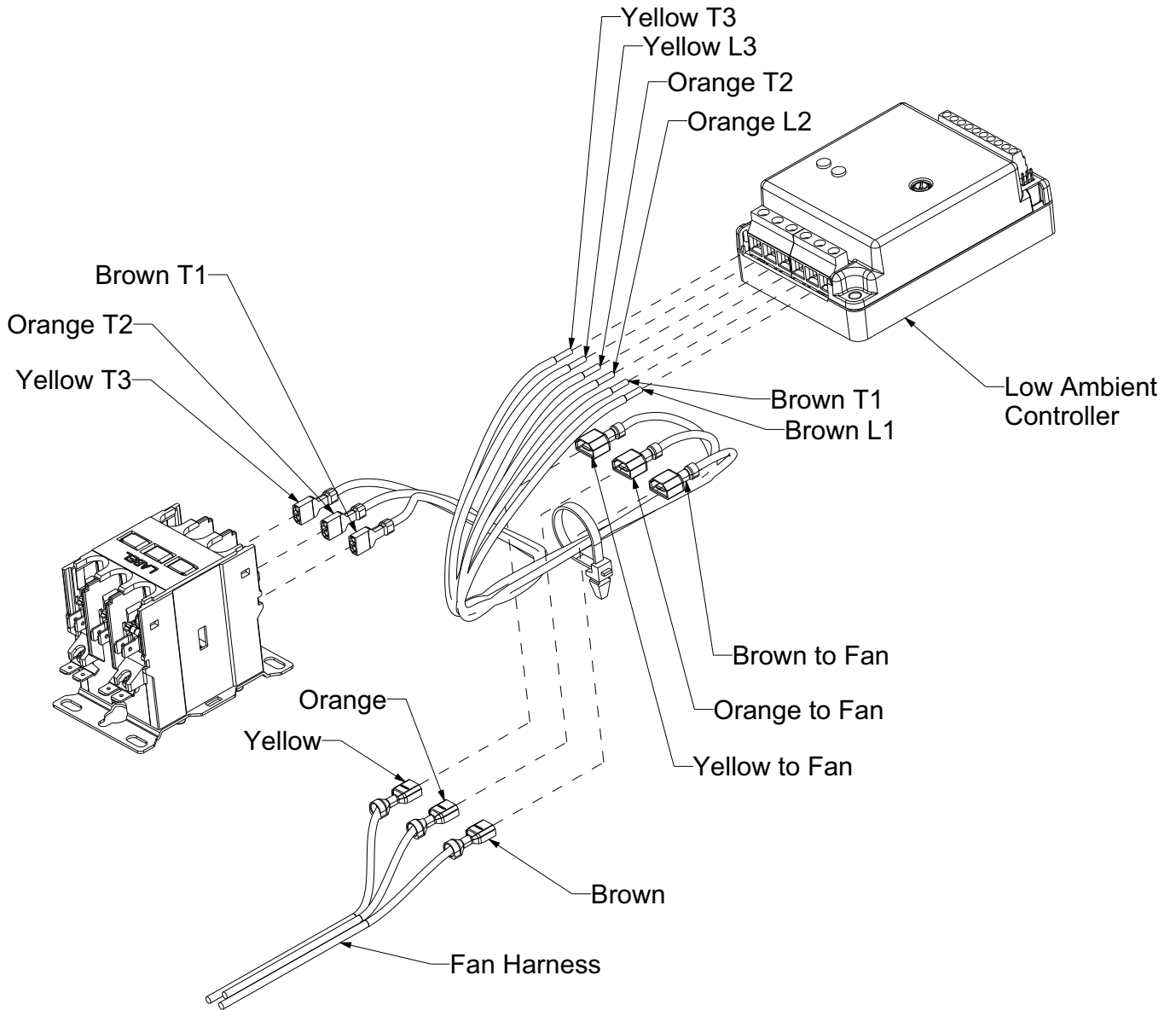

**Figure 10. Switch over valve connections 1**

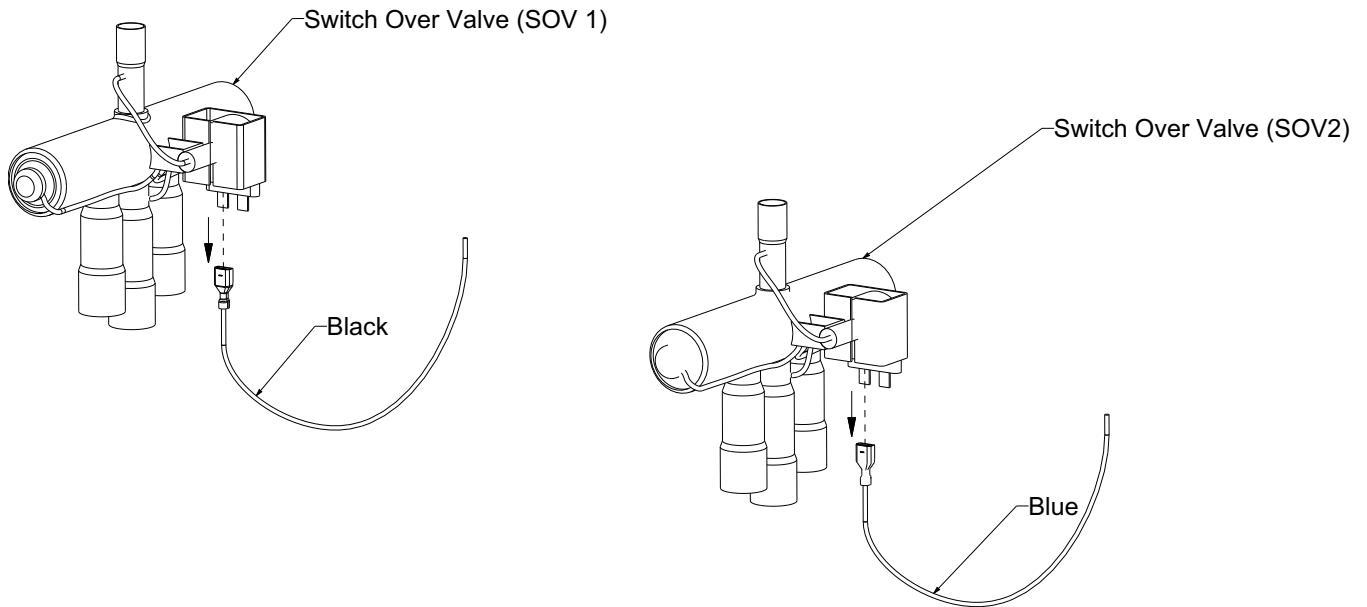

**Figure 11. Switch over connections**

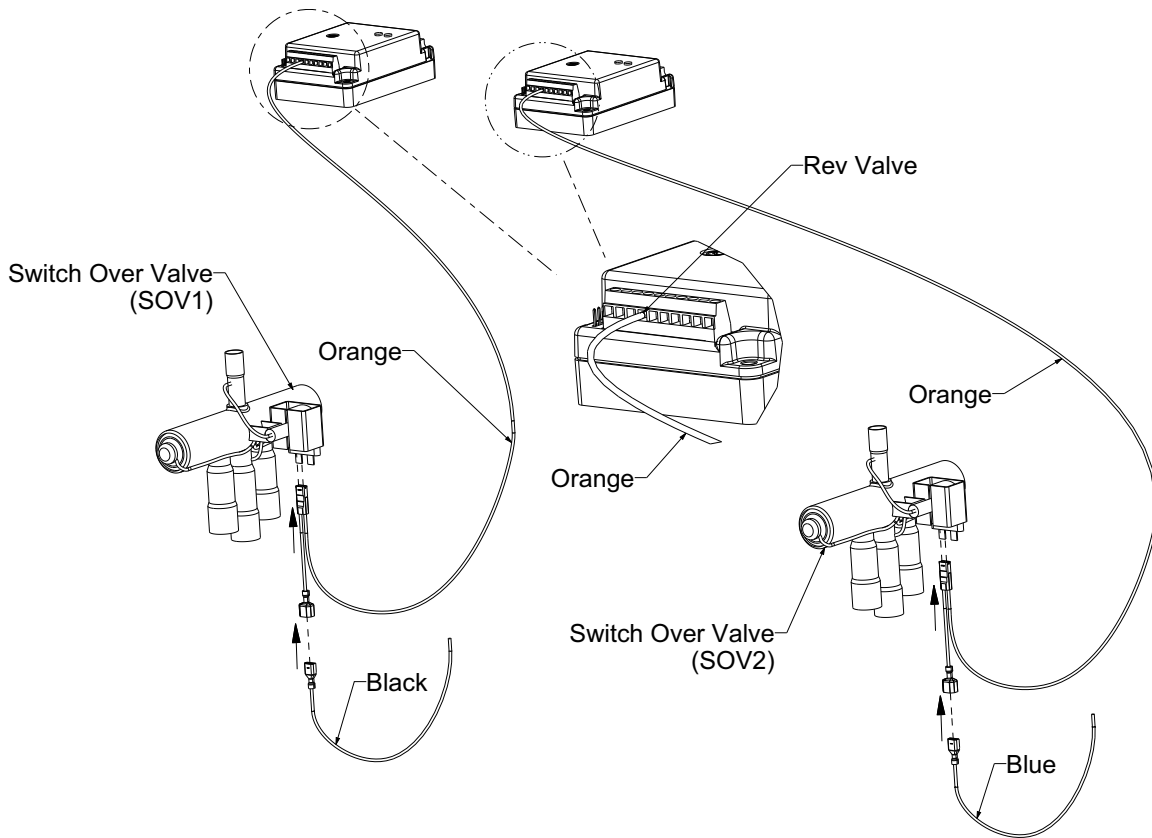

Figure 12. Jumper harness

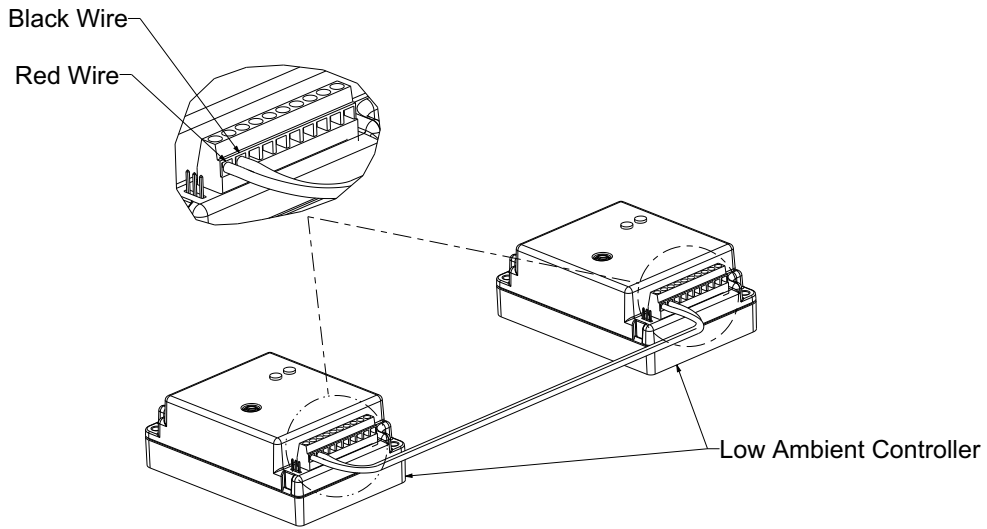

Figure 13. Installing 24VAC harness

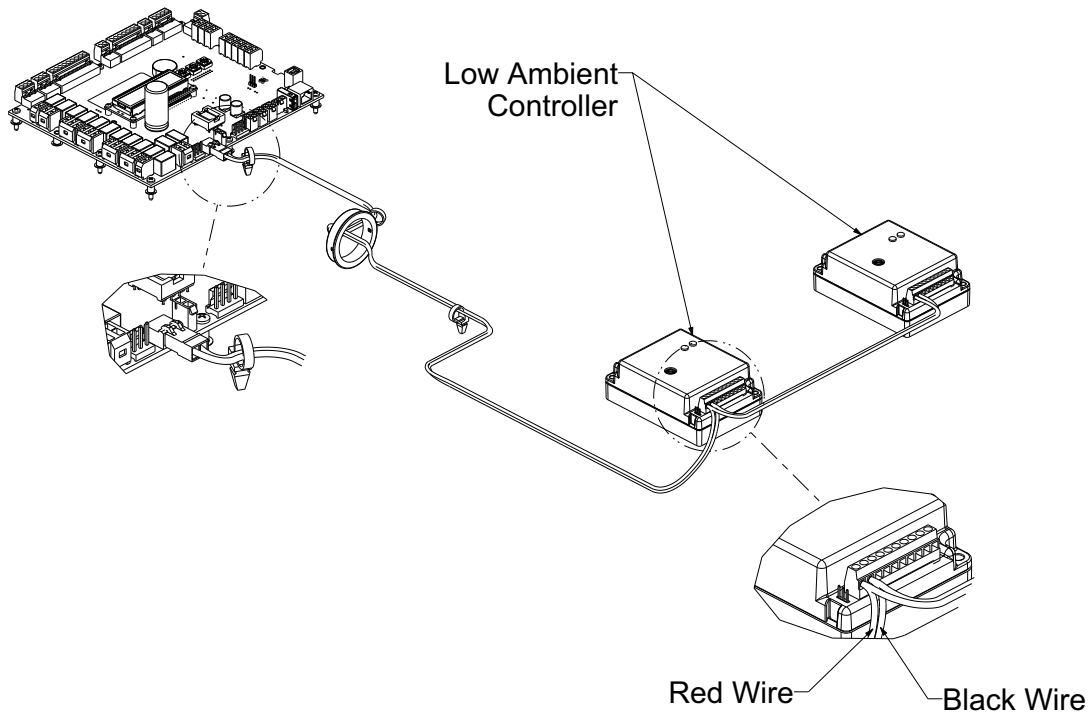

Figure 14. Transducer wires

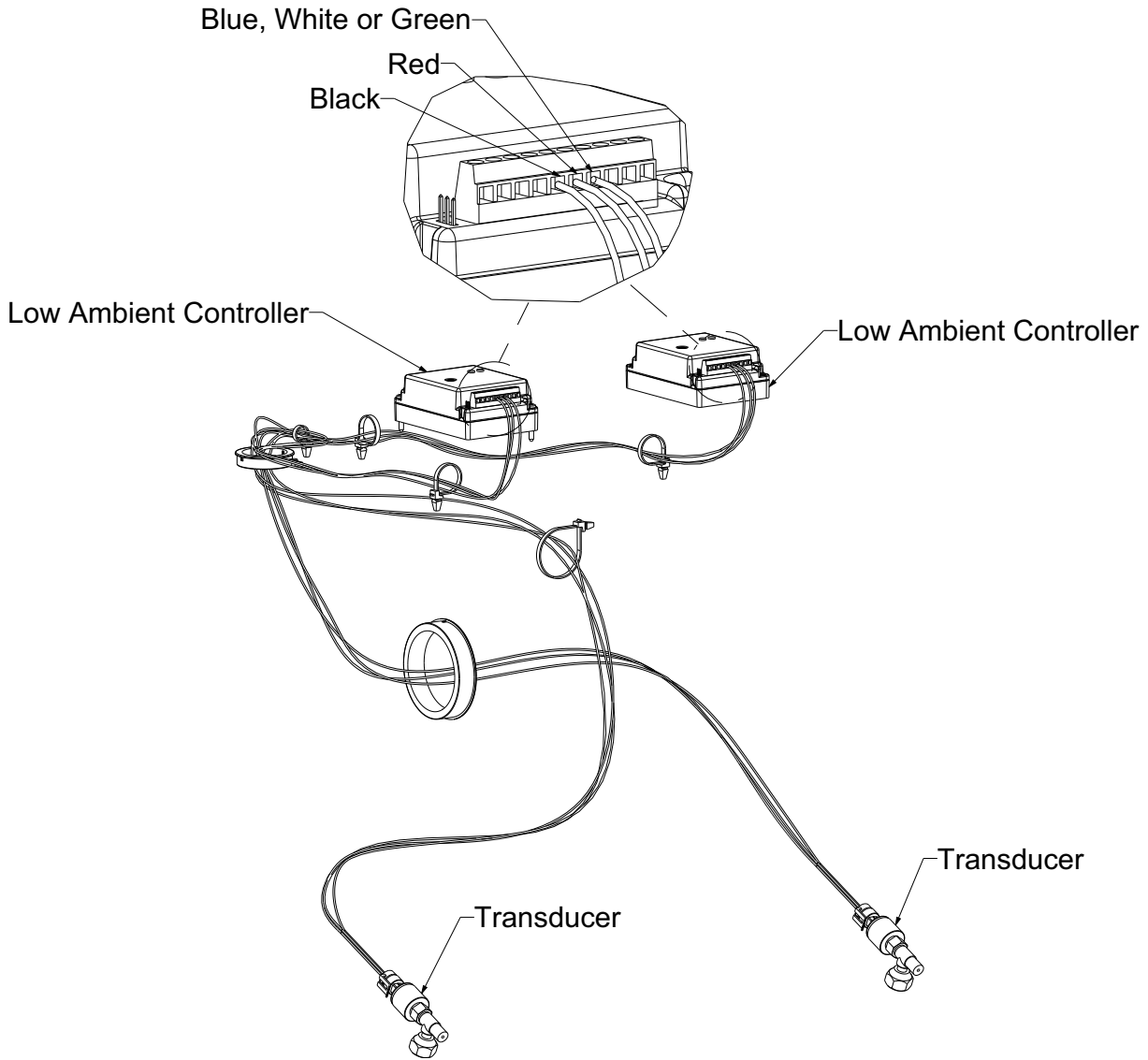
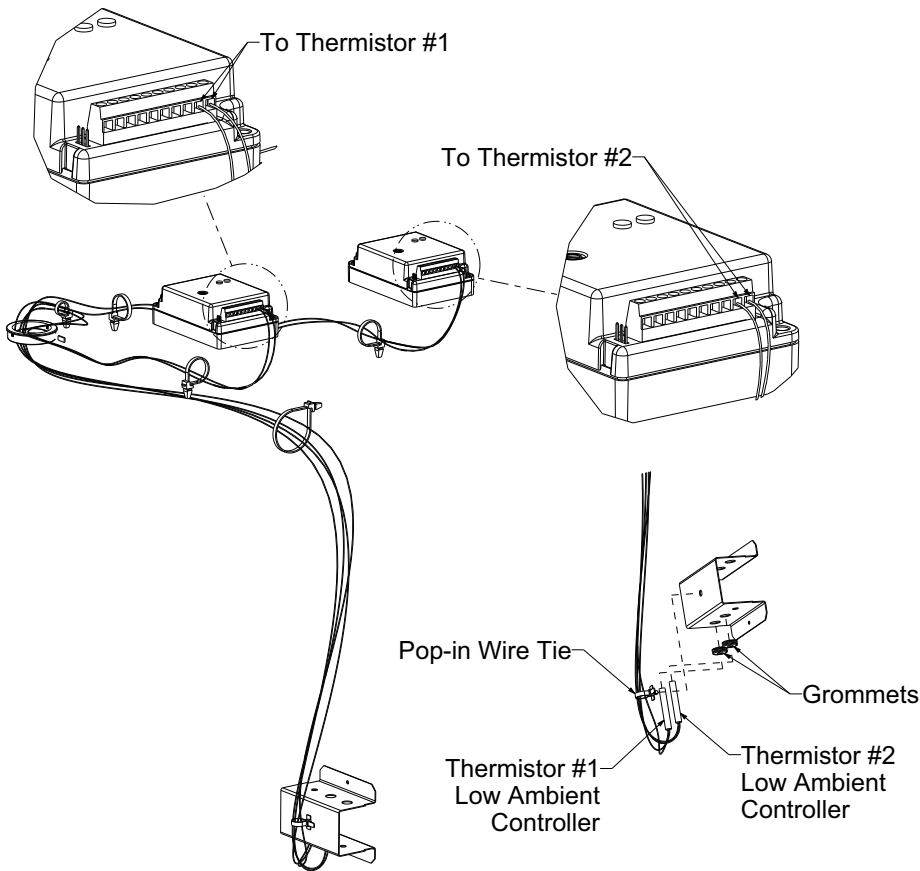

Figure 15. Thermistor wires



**Controller Settings**

**Jumper Position for TTA Models (Cooling Only)**

For non-heat pump applications, the heat pump select jumper must be in the Default (N.O.) position, and the HP terminals must be left unconnected. Refer to Figure 16, p. 15.

Figure 16. Jumper position for TTA

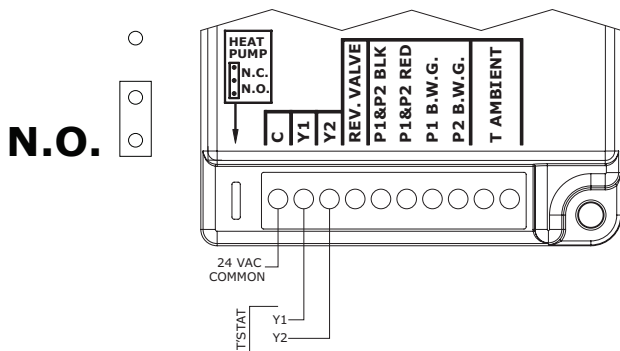

**Jumper Position for TWA Models (Heat Pump)**

For heat pump applications, the heat pump select jumper must be in the (N.C.) position, see Figure 17, p. 15.

Figure 17. Jumper position for TWA

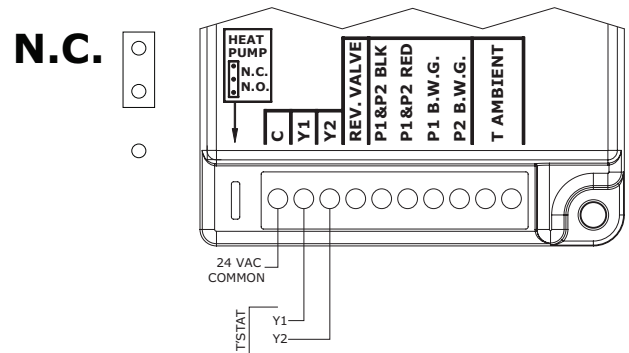

**Operation**

The low ambient controller is used to maintain head pressure within an acceptable range when ambient temperature falls below 50 °F. It reads discharge pressure from the refrigeration circuit and “cycles” the outdoor fan motor on and off to maintain the desired discharge

# Installation

pressure at the selected setpoint anytime the compressor is operating.

## Set Pressure Setpoint

The pressure setpoint should be adjusted to 250 psig for R-410A refrigerant and 230 psig for R-454B refrigerant. When the ambient temperature is above 50°F (10°C), the outdoor fan motor will be energized continuously. When the ambient temperature is below 50°F, the pressure sensor reading is used to switch the motor on or off. When the

pressure is 15psi below the set pressure the motor will be turned off. When the pressure is 15psi above the set pressure, the motor will be turned on.

After completion of installation and pressure setting adjustment), reinstall the compressor and control box access panels and secure with screws that were removed.

Reconnect all power to the unit. Refer to troubleshooting guide, if needed.

**Figure 18. Supplemental wiring diagram**

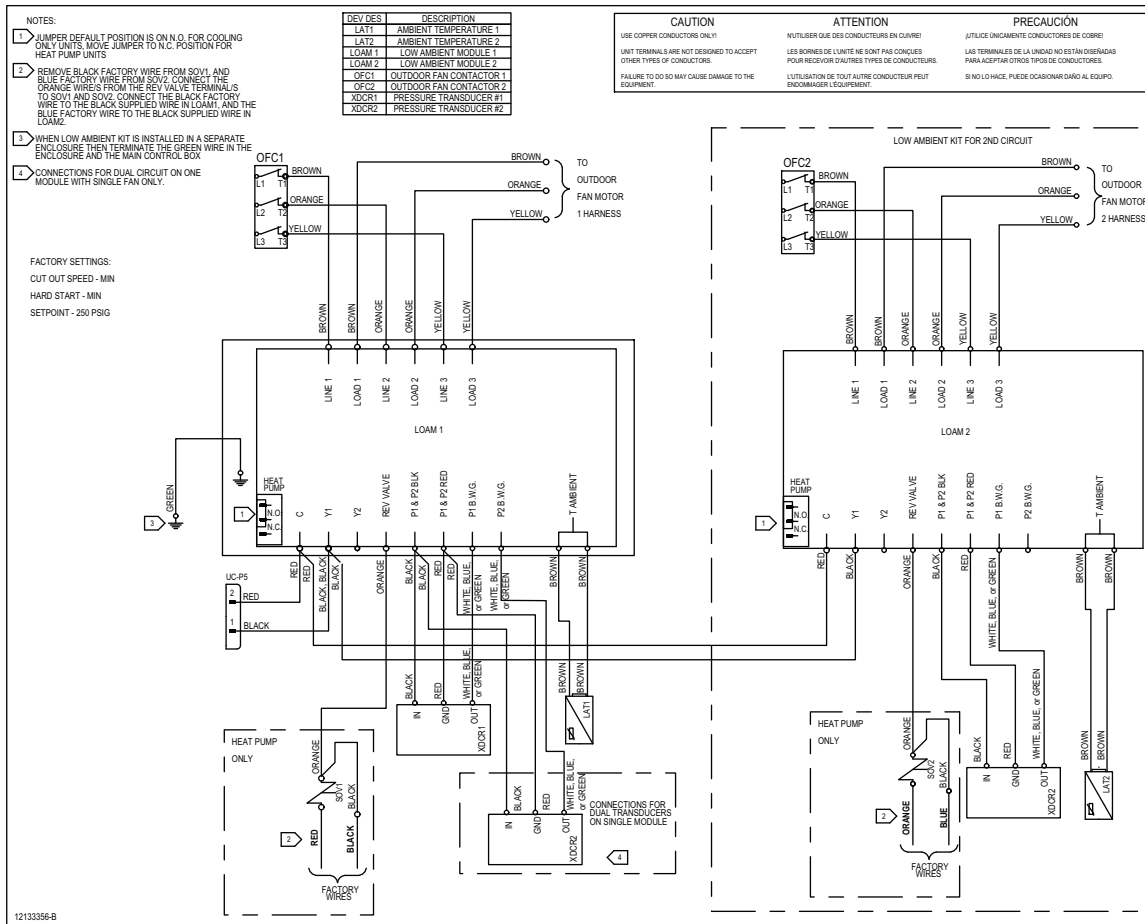



# Operation and Troubleshooting

## Checkout Procedure

Before leaving the installation, observe for correct operation through the desired pressure range (see [Table 3, p. 18](#)).

**⚠ WARNING**

**Hazardous Service Procedures!**  
 Failure to follow all precautions in this manual and on the tags, stickers, and labels could result in death or serious injury.  
 Technicians, in order to protect themselves from potential electrical, mechanical, and chemical hazards, **MUST** follow precautions in this manual and on the tags, stickers, and labels, as well as the following instructions: Unless specified otherwise, disconnect all electrical power including remote disconnect and discharge all energy storing devices such as capacitors before servicing. Follow proper lockout/tagout procedures to ensure the power can not be inadvertently energized. When necessary to work with live electrical components, have a qualified licensed electrician or other individual who has been trained in handling live electrical components perform these tasks.

**Table 2. Troubleshooting guide**

Problem	Possible Cause	Possible Solution
No fan operation	No 24 volt control voltage	Check for 24 Vac between Y1 or Y2 and C terminals - it should read 24 volts.
	No line voltage	Check voltage across brown, orange, and yellow motor leads. If no voltage is present verify all wiring is correct.
	Bad fan motor or controller	If fan does not start, motor is bad and should be replaced. If motor does start, check controller settings. If motor still fails to start, replace controller.
Improper fan operation	Heat pump jumper not configured correctly	Verify the heat pump jumper is configured correctly.
	Control is not wired correctly	See wiring diagrams. Ensure that the 24 Vac power supply is connected.
No fan modulation	No need to modulate the fan	If pressure is equal to or greater than the head pressure control setpoint, the fan will be operating at full speed.
	No input pressure to control	Check for proper transducer and Tee installation. Schrader valve depressor must depress Schrader valve enough to allow refrigerant into pressure transducer.
	Heat pump inputs wired incorrectly into the controller	Check diagram and verify heat pump inputs are properly wired into the controller.
	Miswired	Check that the 24 Vac signal and the transducer are wired up correctly into the controller.
Erratic fan operation	Control is not wired correctly	See wiring diagrams.
	Pressure transducer problem	Check for proper transducer and Tee installation. Schrader valve depressor must depress Schrader valve enough to allow refrigerant into pressure transducer.
	Dirty or blocked condenser coil	Clean condenser coil.
The high pressure switch trips off	Improper head pressure setpoint setting	See unit fails to start above.
		Check the setpoint and reduce it if needed.
Reduced cooling capacity at low Ambient	Evaporative Defrost Control is active	Disable EDC function in Symbio™ 700

Table 3. Pressure vs. voltage

Pressure (psig)	Voltage (Vdc)
0	0.5
50	0.9
100	1.3
150	1.7
200	2.1
250	2.5
300	2.9
350	3.3
400	3.7
450	4.1
500	4.5



Trane and American Standard create comfortable, energy efficient indoor environments for commercial and residential applications. For more information, please visit [trane.com](http://trane.com) or [americanstandardair.com](http://americanstandardair.com).

Trane and American Standard have a policy of continuous product and product data improvement and reserve the right to change design and specifications without notice. We are committed to using environmentally conscious print practices.

ACC-SVN190C-EN 11 Aug 2024  
Supersedes ACC-SVN190B-EN (August 2021)

©2024