

## Installation Instructions

# Reference Enthalpy

## Foundation™ Packaged Rooftop Units with Low Leak Economizer 15 to 25 Tons

Model Number: BAYENTH302\*  
Used With: E/GCC180-300

### SAFETY WARNING

Only qualified personnel should install and service the equipment. The installation, starting up, and servicing of heating, ventilating, and air-conditioning equipment can be hazardous and requires specific knowledge and training. Improperly installed, adjusted or altered equipment by an unqualified person could result in death or serious injury. When working on the equipment, observe all precautions in the literature and on the tags, stickers, and labels that are attached to the equipment.

August 2024

ACC-SVN179F-EN

©2024

## Warnings, Cautions, and Notices

Read this manual thoroughly before operating or servicing this unit. Safety advisories appear throughout this manual as required. Your personal safety and the proper operation of this machine depend upon the strict observance of these precautions.

The three types of advisories are defined as follows:

**WARNING** Indicates a potentially hazardous situation which, if not avoided, could result in death or serious injury.

**CAUTION** Indicates a potentially hazardous situation which, if not avoided, could result in minor or moderate injury. It could also be used to alert against unsafe practices.

**NOTICE** Indicates a situation that could result in equipment or property-damage only accidents.

### Important Environmental Concerns

Scientific research has shown that certain man-made chemicals can affect the earth's naturally occurring stratospheric ozone layer when released to the atmosphere. In particular, several of the identified chemicals that may affect the ozone layer are refrigerants that contain Chlorine, Fluorine and Carbon (CFCs) and those containing Hydrogen, Chlorine, Fluorine and Carbon (HCFCs). Not all refrigerants containing these compounds have the same potential impact to the environment. Trane advocates the responsible handling of all refrigerants.

### Important Responsible Refrigerant Practices

Trane believes that responsible refrigerant practices are important to the environment, our customers, and the air conditioning industry. All technicians who handle refrigerants must be certified according to local rules. For the USA, the Federal Clean Air Act (Section 608) sets forth the requirements for handling, reclaiming, recovering and recycling of certain refrigerants and the equipment that is used in these service procedures. In addition, some states or municipalities may have additional requirements that must also be adhered to for responsible management of refrigerants. Know the applicable laws and follow them.

## WARNING

**Proper Field Wiring and Grounding Required!** Failure to follow code could result in death or serious injury. All field wiring MUST be performed by qualified personnel. Improperly installed and grounded field wiring poses FIRE and ELECTROCUTION hazards. To avoid these hazards, you MUST follow requirements for field wiring installation and grounding as described in NEC and your local/state/national electrical codes.

## WARNING

**Personal Protective Equipment (PPE) Required!** Failure to wear proper PPE for the job being undertaken could result in death or serious injury. Technicians, in order to protect themselves from potential electrical, mechanical, and chemical hazards, MUST follow precautions in this manual and on the tags, stickers, and labels, as well as the instructions below:

- Before installing/servicing this unit, technicians MUST put on all PPE required for the work being undertaken (Examples; cut resistant gloves/sleeves, butyl gloves, safety glasses, hard hat/bump cap, fall protection, electrical PPE and arc flash clothing). ALWAYS refer to appropriate Safety Data Sheets (SDS) and OSHA guidelines for proper PPE.
- When working with or around hazardous chemicals, ALWAYS refer to the appropriate SDS and OSHA/GHS (Global Harmonized System of Classification and Labeling of Chemicals) guidelines for information on allowable personal exposure levels, proper respiratory protection and handling instructions.
- If there is a risk of energized electrical contact, arc, or flash, technicians MUST put on all PPE in accordance with OSHA, NFPA 70E, or other country-specific requirements for arc flash protection, PRIOR to servicing the unit. NEVER PERFORM ANY SWITCHING, DISCONNECTING, OR VOLTAGE TESTING WITHOUT PROPER ELECTRICAL PPE AND ARC FLASH CLOTHING. ENSURE ELECTRICAL METERS AND EQUIPMENT ARE PROPERLY RATED FOR INTENDED VOLTAGE.

## WARNING

- Follow EHS Policies!** Failure to follow instructions below could result in death or serious injury.
- All Trane personnel must follow the company's Environmental, Health and Safety (EHS) policies when performing work such as hot work, electrical, fall protection, lockout/tagout, refrigerant handling, etc. Where local regulations are more stringent than these policies, those regulations supersede these policies.
  - Non-Trane personnel should always follow local regulations.

### Copyright

This document and the information in it are the property of Trane, and may not be used or reproduced in whole or in part without written permission. Trane reserves the right to revise this publication at any time, and to make changes to its content without obligation to notify any person of such revision or change.

### Trademarks

All trademarks referenced in this document are the trademarks of their respective owners.

## Inspection

1. Unpack all components of the BAYENTH302\* kit.
2. Check carefully for shipping damage. If any damage is found, report it immediately, and file a claim against the transportation company.

### Parts List

Quantity	Description
1	Outside Air Temperature/Humidity Sensor
2	Screws 6-32 X 0.75
1	Outside Air Temperature/Humidity Sensor Wire Harness
2	Pop-in Wire Ties
1	Label (placed next to unit nameplate)

## Installation Procedure (Field Installed)

### WARNING

**Hazardous Voltage w/Capacitors!** Failure to disconnect power and discharge capacitors before servicing could result in death or serious injury. Disconnect all electric power, including remote disconnects and discharge all motor start/run capacitors before servicing. Follow proper lockout/tagout procedures to ensure the power cannot be inadvertently energized. Verify with a CAT III or IV voltmeter rated per NFPA 70E that all capacitors have discharged.

### NOTICE

**Electrostatic Discharge!** Electrostatic discharge can short equipment circuitry. Ensure that you are properly grounded before handling sensitive electronic equipment.

1. Remove filter access panel. See Figure 1.

Figure 1. Remove filter access panel

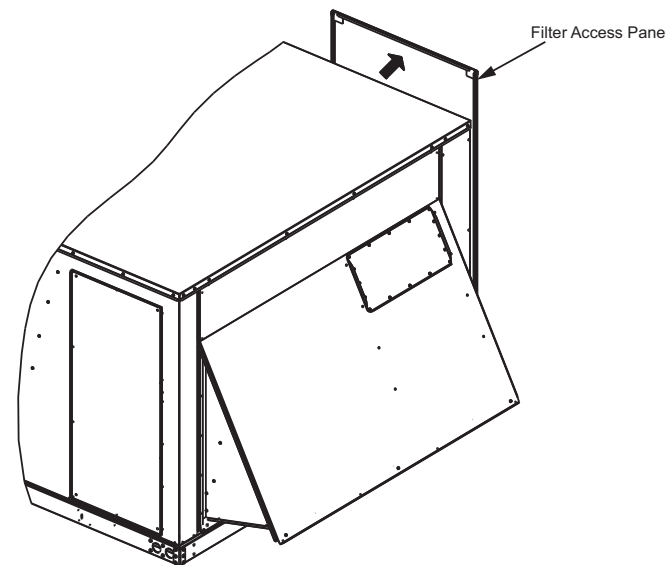

2. Remove the four screws from the outside air sensor plate located on the fresh air damper enclosure below the economizer controller. See Figure 2.
3. Remove current outdoor air temperature sensor attached to the plate and disconnect OAT sensor harness from the OAT pin on the controller. Discard the existing OAT and OAT harness.

**Note:** The new sensor in this kit reads both temperature and humidity. The OAT sensor harness must be removed from the OAT pin on the controller or the controller will display a configuration error.

2. Remove sensor

Figure 2. Remove sensor

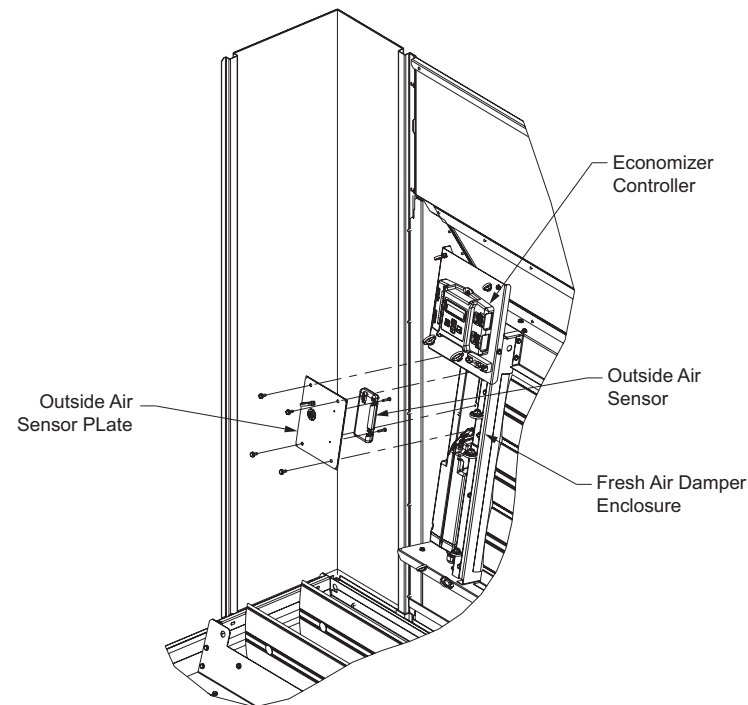

4. Remove new outside air temperature/humidity (OAE) sensor from box and verify DIP switch settings are set to OA per the label on the sensor. See Figure 3 and Table 1.

**Note:** The protective film on the DIP switch is only necessary during the factory assembly process. Simply push through the film to set the DIP switches; this will not harm the device.

Figure 3. Verify DIP switches on new sensor

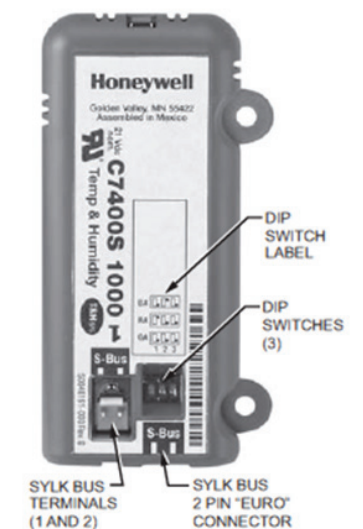

Table 1. Sensor DIP switch positions for switches 1, 2, and 3

Use	1	2	3
RA	ON	OFF	OFF
OA	OFF	OFF	OFF

RA = Return Air Temp/Humidity  
OA = Outside Air Temp/Humidity (Default Setting)

5. Secure the OAE sensor to plate using the screws provided in this kit as shown in Figure 4.

Figure 4. Attach outside sensor to plate

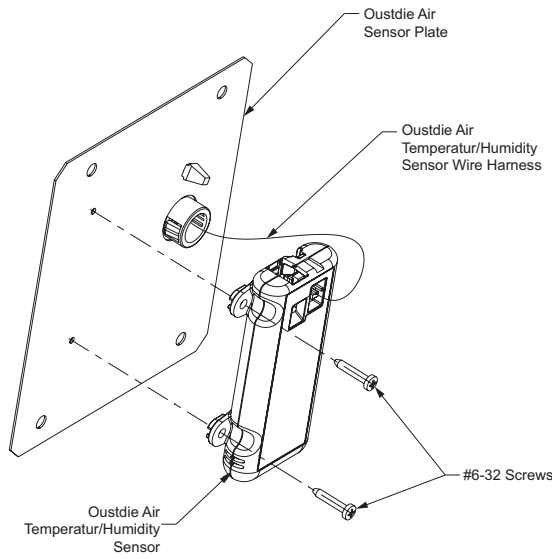

6. Connect OAE sensor harness (from this kit) to S-BUS pins on sensor and route through bushing in plate. See Figure 4.
7. Reattach plate with attached OAE sensor to fresh air damper enclosure with four screws. See Figure 2.
8. Route harness to controller using pop-in wire ties provided in locations shown in Figure 5.
9. Connect OAE harness (from this kit) to S-BUS pins on controller and route through bushing in plate. See Figure 5.

**Note:** The OAT, MAT and S-BUS pins on the controller are polarity insensitive.

Figure 5. Wire routing and connections

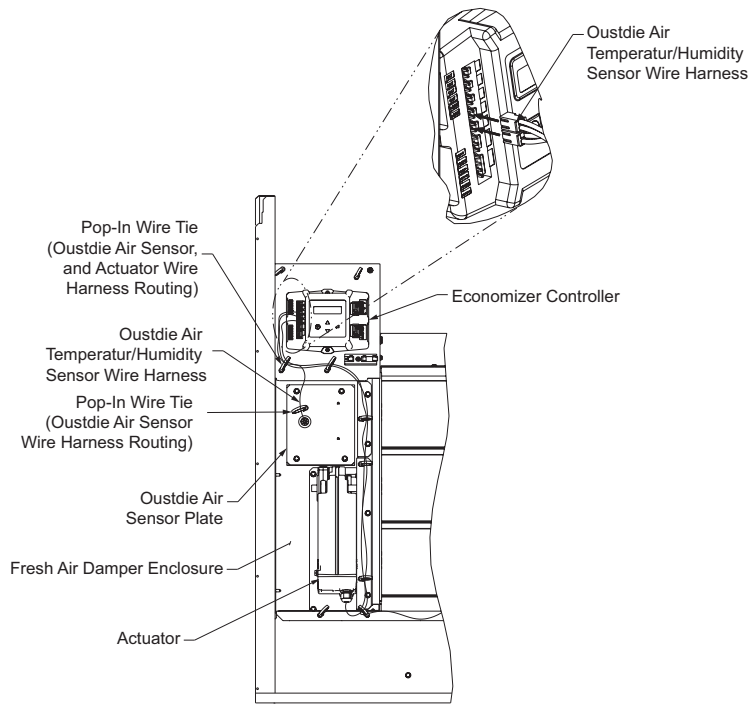

**Note:** The labels on the sensors and controller are color coded for ease of installation. Orange labeled sensors can only be wired to orange terminals on the controller. Brown labeled sensors can only be wired to the S-BUS (brown) terminals.

Controller Setup (Field and Factory Installed)

1. Verify the correct ENTH CURVE parameter is set in the economizer controller. See Table 2.

**Note:** The default parameter value for enthalpy is set to ES3 on the controller.

Table 2. Single enthalpy and dual enthalpy boundaries (parameters ES1 through ES5)

Enth. Curve	Temp. Dry-Bulb (°F)	Temp. Dew Point (°F)	Enthalpy (btu/lb/da)	Point P1		Point P2	
				Temp. °F	Humidity %RH	Temp. °F	Humidity %RH
ES1	80.0	60.0	28.0	80.0	36.8	66.3	80.1
ES2	75.0	57.0	26.0	75.0	39.6	63.3	80.0
ES3	70.0	54.0	24.0	70.0	42.3	59.7	81.4
ES4	65.0	51.0	22.0	65.0	44.8	55.7	84.2
ES5	60.0	48.0	20.0	60.0	46.9	51.3	88.5
HL	86.0	66.0	32.4	86.0	38.9	72.4	80.3

**Note:** For differential enthalpy there is a high limit boundary. The high limit boundary is ES1 when there are no stages of mechanical cooling energized and HL when a compressor stage is energized.

2. To change the enthalpy parameter on the controller use the down arrow, navigate to SETPOINTS, and press Enter. Then scroll down (using down arrow) to ENTH CURVE, press Enter and use the up/down arrow to view the parameter values. To select the parameter, press Enter to accept the displayed value and store it in non-volatile RAM. The screen will then display CHANGE STORED. Press the Menu (Up/Exit) button to return to the previous menu. See Table 2 and Figure 6.

Notes:

- During setup, the economizer module is live at all times.
  - Parameter OA T CAL and OA H CAL under Advanced Setup menu allow for the operator to adjust for an out of calibration sensor (see 0-100% Low Leak Economizer - Downflow/Horizontal Installation Instructions (ACC-SVN178\*-EN) for full list of set points).
  - There will be a slight delay during start-up while the controller and OAE sensor communicate.
3. Place label next to unit nameplate.
  4. Secure filter access panel back on to the unit.

Figure 6. Single enthalpy curve and boundaries

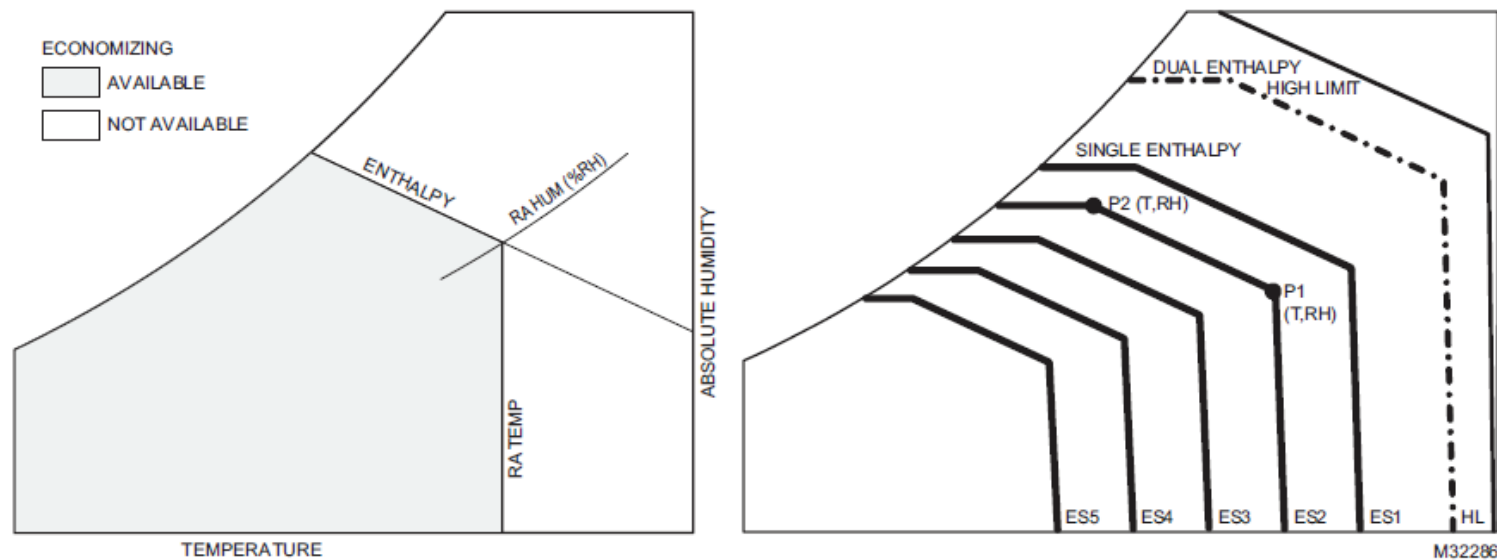

Trane and American Standard create comfortable, energy efficient indoor environments for commercial and residential applications. For more information, please visit [trane.com](http://trane.com) or [americanstandardair.com](http://americanstandardair.com).

Trane and American Standard have a policy of continuous product and product data improvement and reserve the right to change design and specifications without notice. We are committed to using environmentally conscious print practices.