

# Installation Instructions

## LonTalk® Communications Interface with ReliaTel™ Controls

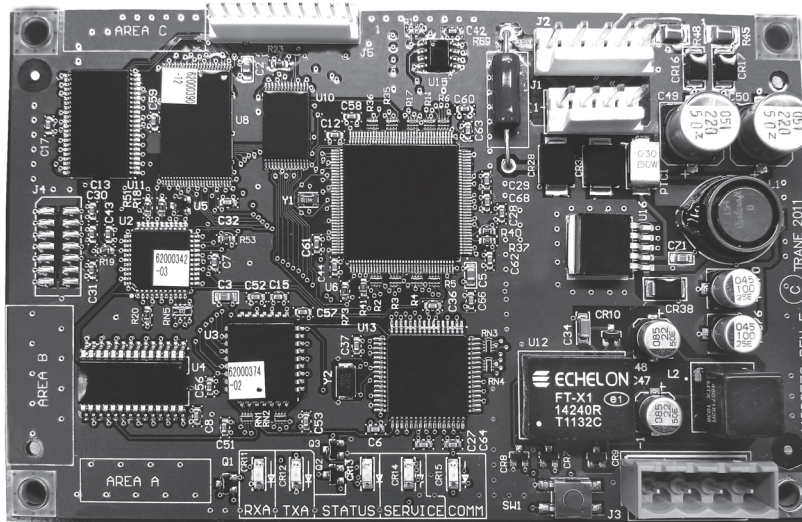

### CV\_ModelNum:

**BAYLTCI002\***

### Used With:

3 to 10 Tons Packaged Rooftop units with ReliaTel™ Communications Module,  
6 to 25 Tons Split System units with ReliaTel™ Communications Module

**BAYLTCI003\***

12.5 to 25 Tons Packaged Rooftop units with ReliaTel™ Communications Module,  
27.5 to 50 Tons Packaged Rooftop units with ReliaTel™ Communications Module

**BAYLTCI004\***

27.5 to 50 Tons Variable Air Volume (VAV) Packaged Rooftop Air Conditioners (YC, TC, TE)  
with ReliaTel™ Communications Module

### **⚠ SAFETY WARNING**

Only qualified personnel should install and service the equipment. The installation, starting up, and servicing of heating, ventilating, and air-conditioning equipment can be hazardous and requires specific knowledge and training. Improperly installed, adjusted or altered equipment by an unqualified person could result in death or serious injury. When working on the equipment, observe all precautions in the literature and on the tags, stickers, and labels that are attached to the equipment.

# Introduction

Read this manual thoroughly before operating or servicing this unit.

## Warnings, Cautions, and Notices

Safety advisories appear throughout this manual as required. Your personal safety and the proper operation of this machine depend upon the strict observance of these precautions.

The three types of advisories are defined as follows:

**⚠ WARNING** Indicates a potentially hazardous situation which, if not avoided, could result in death or serious injury.

**⚠ CAUTION** Indicates a potentially hazardous situation which, if not avoided, could result in minor or moderate injury. It could also be used to alert against unsafe practices.

**NOTICE** Indicates a situation that could result in equipment or property-damage only accidents.

## Important Environmental Concerns

Scientific research has shown that certain man-made chemicals can affect the earth's naturally occurring stratospheric ozone layer when released to the atmosphere. In particular, several of the identified chemicals that may affect the ozone layer are refrigerants that contain Chlorine, Fluorine and Carbon (CFCs) and those containing Hydrogen, Chlorine, Fluorine and Carbon (HCFCs). Not all refrigerants containing these compounds have the same potential impact to the environment. Trane advocates the responsible handling of all refrigerants-including industry replacements for CFCs and HCFCs such as saturated or unsaturated HFCs and HCFCs.

## Important Responsible Refrigerant Practices

Trane believes that responsible refrigerant practices are important to the environment, our customers, and the air conditioning industry. All technicians who handle refrigerants must be certified according to local rules. For the USA, the Federal Clean Air Act (Section 608) sets forth the requirements for handling, reclaiming, recovering and recycling of certain refrigerants and the equipment that is used in these service procedures. In addition, some states or municipalities may have additional requirements that must also be adhered to for responsible management of refrigerants. Know the applicable laws and follow them.

### ⚠ WARNING

#### Proper Field Wiring and Grounding Required!

Failure to follow code could result in death or serious injury. All field wiring **MUST** be performed by qualified personnel. Improperly installed and grounded field wiring poses **FIRE** and **ELECTROCUTION** hazards. To avoid these hazards, you **MUST** follow requirements for field wiring installation and grounding as described in **NEC** and your local/state electrical codes.

### ⚠ WARNING

#### Personal Protective Equipment (PPE) Required!

Failure to wear proper PPE for the job being undertaken could result in death or serious injury. Technicians, in order to protect themselves from potential electrical, mechanical, and chemical hazards, **MUST** follow precautions in this manual and on the tags, stickers, and labels, as well as the instructions below:

- Before installing/servicing this unit, technicians **MUST** put on all PPE required for the work being undertaken (Examples; cut resistant gloves/sleeves, butyl gloves, safety glasses, hard hat/bump cap, fall protection, electrical PPE and arc flash clothing). **ALWAYS** refer to appropriate Safety Data Sheets (SDS) and OSHA guidelines for proper PPE.
- When working with or around hazardous chemicals, **ALWAYS** refer to the appropriate SDS and OSHA/GHS (Global Harmonized System of Classification and Labeling of Chemicals) guidelines for information on allowable personal exposure levels, proper respiratory protection and handling instructions.
- If there is a risk of energized electrical contact, arc, or flash, technicians **MUST** put on all PPE in accordance with OSHA, NFPA 70E, or other country-specific requirements for arc flash protection, **PRIOR** to servicing the unit. **NEVER PERFORM ANY SWITCHING, DISCONNECTING, OR VOLTAGE TESTING WITHOUT PROPER ELECTRICAL PPE AND ARC FLASH CLOTHING. ENSURE ELECTRICAL METERS AND EQUIPMENT ARE PROPERLY RATED FOR INTENDED VOLTAGE.**

**⚠ WARNING**

**Follow EHS Policies!**

Failure to follow instructions below could result in death or serious injury.

- All Trane personnel must follow the company's Environmental, Health and Safety (EHS) policies when performing work such as hot work, electrical, fall protection, lockout/tagout, refrigerant handling, etc. Where local regulations are more stringent than these policies, those regulations supersede these policies.
- Non-Trane personnel should always follow local regulations.

## Copyright

This document and the information in it are the property of Trane, and may not be used or reproduced in whole or in part without written permission. Trane reserves the right to revise this publication at any time, and to make changes to its content without obligation to notify any person of such revision or change.

## Trademarks

All trademarks referenced in this document are the trademarks of their respective owners.

## Revision History

Addition of new heat pump and eFlex™ models.

# Table of Contents

General Information .....	5	NV#6 Occupancy Override Input .....	17
Installation .....	6	NV#7 Occupancy Sensor Input .....	17
LonTalk® Communication Link Wiring Re-		NV# 8 Application Mode Input .....	17
quirements .....	8	NV#9 Heat/Cool Mode Input .....	18
Network Interface .....	9	Fan Mode Command .....	18
Network Variables .....	9	NV#11 Compressor Enable Input .....	18
Configuration Properties .....	10	NV#12 Auxiliary Heat Enable Input .....	19
Exhaust Enable Position .....	10	NV#13 Economizer Enable Input .....	19
Duct Static Pressure Set Point .....	11	NV#17 Emergency Override Input .....	19
Discharge Air Cooling Set Point .....	11	NV#22 Space CO2 Input .....	20
Discharge Air Heating Set Point .....	11	NV#59 Outdoor Air Damper Minimum Posi-	
Send Heartbeat .....	12	tion Input .....	20
Occupancy Temperature Setpoint .....	12	NV#21 Outdoor Relative Humidity Input ..	20
Minimum Send Time .....	12	NV#19 Outdoor Temperature Input .....	20
Receive Heartbeat .....	12	NV#20 Space Relative Humidity Input ..	21
Location Label .....	12	NV#26 Effective Space Temperature	
Local Bypass Time .....	12	Output .....	21
Outdoor Air Damper Minimum Position	12	NV#28 Effective Setpoint Output .....	21
Space Humidity Set Point .....	13	NV#27 Unit Status Output .....	22
Space CO2 Limit .....	13	NV#29 Effective Occupancy Output .....	24
Node Object .....	13	NV#30 Effective Heat/Cool Output .....	25
Self-Documentation .....	13	NV#31 Local Setpoint Output .....	27
Network Variable Descriptions: .....	13	NV#33 Fan Speed Output .....	27
NV#6 Duct Static Pressure Set Point .....	13	NV#34 Discharge Air Temperature	
NV#7 Discharge Air Cooling Set Point ..	14	Output .....	27
NV#8 Discharge Air Heating Set Point ..	14	NV#36 Absolute Power Consumption	
Effect Discharge Air Temperature Set		Output .....	28
Point .....	14	NV#37 Terminal Load Output .....	28
Effect Duct Static Pressure .....	14	NV#42 Outdoor Air Damper Output .....	28
Effect Duct Static Pressure Set Point ..	14	NV#43 Space Humidity Output .....	28
Application Mode .....	15	NV#44 Outdoor Air Humidity Output .....	29
Supply Fan Status .....	15	NV#45 Outdoor Air Temperature Output ..	29
Exhaust Fan Status .....	15	NV#46 Space CO2 Output .....	29
Economizer Enabled .....	15	Mixed Air Temperature Output .....	29
NV#1 Space Temperature Input .....	16	Return Air Temperature Output .....	30
NV#2 Temperature Setpoint Input		NV#64 Mixed Air Temperature Output ..	30
(absolute) .....	16		
NV#3 Setpoint Offset Input .....	16		
NV#5 Occupancy Scheduler Input .....	16		

# General Information

The Communication Interface board allows ReliaTel™ controls to communicate on a LonTalk® Network at the unit level. This product is intended to be installed by a qualified System Integrator properly trained and experienced in LonTalk® networks. Network variables are based on the LonMark® Functional Profile Template. The LCI-R utilizes a Free Topology transceiver FTT-10A. The FTT-10A transceiver supports non-polarity sensitive, free topology wiring, allowing the system installer to utilize star, bus, and loop architecture.

## LCI-R Shipment and Inspection

The Kit (BAYLTCI002\* or BAYLTCI003\*) includes: a ReliaTel™ LCI-R communications board, a wiring harness and the mounting hardware needed for installation on a Packaged Rooftop Unit with ReliaTel™ Communications Module.

LCI-R kits include the following items:

- 1 - LCI-R communications board
- 1 - Wire harness
- 4 - LCI-R board mounting screws
- 1 - Pop-in wire tie (BAYLTCI002\*)

## Storage

When the LCI-R board must be stored for a period of time prior to being installed, it must be protected from the elements. The temperature of the storage location should be between -40° C and 65.6°C (-40° F and 150° F) and the relative humidity should be 10 to 90 percent, non-condensing.

## Mounting and Wiring

The LCI-R board mounts directly in the Unit Control Box. The following procedure explains how to mount and wire the LCI-R board. See [Figure 1, p. 6](#), [Figure 2, p. 6](#), [Figure 3, p. 6](#), [Figure 4, p. 7](#), [Figure 5, p. 7](#), [Figure 6, p. 8](#), [Figure 7, p. 8](#) for LCI-R board mounting location and wire bundle placement.

**Note:** *LCI-R card part number X13651545-01 is incompatible with DCV (Demand Control Ventilation) remote building controls. If the unit is equipped with this model LCI-R card, the unit must be retrofitted with the most current version for remote control of DCV functions. For information regarding configuring the unit locally for use with the incompatible LCI-R module, contact Light Commercial Technical Support.*

# Installation

**Note:** Skip steps 1 – 8 if the LonTalk® Communication Interface board is already factory installed.

**Important:** Must have BAYWRKT003\* when installing TCI board kit on 15 to 20 tons Split System Heat Pump (TWA) units.

**⚠ WARNING**

**Hazardous Voltage w/Capacitors!**

Failure to disconnect power and discharge capacitors before servicing could result in death or serious injury. Disconnect all electric power, including remote disconnects and discharge all motor start/run capacitors before servicing. Follow proper lockout/tagout procedures to ensure the power cannot be inadvertently energized. Verify with an appropriate voltmeter that all capacitors have discharged.

1. Disconnect the power source to the unit and remove the Access Panel to gain access to the electronic controls.
2. Select proper installation depending on tonnage:  
**15 to 25 Tons Split System units:**  
 Mount the LonTalk® Communication Interface board above the ReliaTel™ Refrigeration Module on the control box mounting panel. Secure with 4 screws. See Figure 1, p. 6.

**Figure 1. LonTalk® communication interface board mounting and wiring 15 to 25 tons split system units**

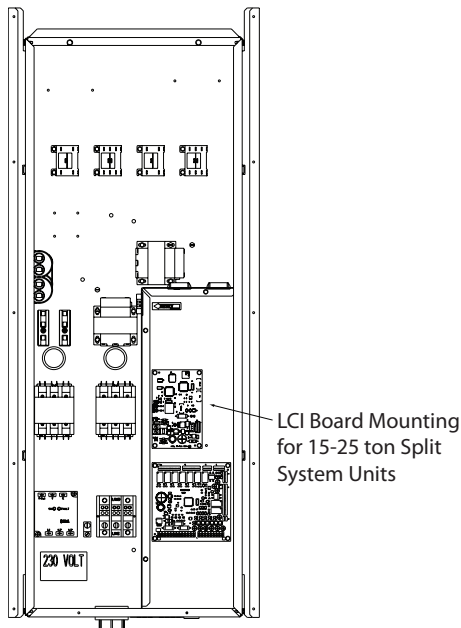

**12.5 to 25 Tons Packaged Rooftop Units:**

Mount the LonTalk® Communication Interface board to the right side of the ReliaTel™ Refrigeration Module by sliding the LonTalk® Communication Interface mounting feet into the mounting extrusions on the control box bottom panel. Secure with 2 screws. See Figure 2, p. 6.

**Figure 2. LonTalk® communication interface board mounting and wiring 12.5 to 25 tons packaged rooftop units - smaller control panel**

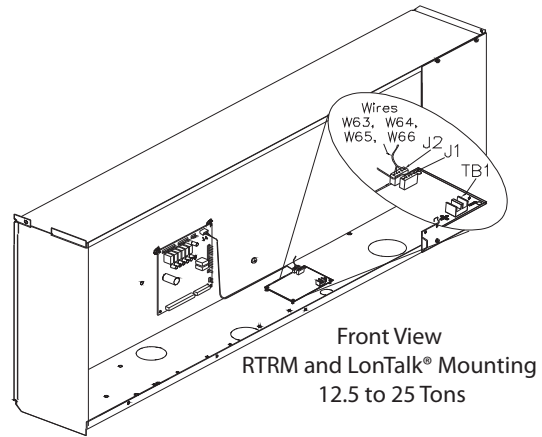

**Figure 3. LonTalk® communication interface board mounting and wiring 12.5 to 25 tons packaged rooftop units - larger control panel**

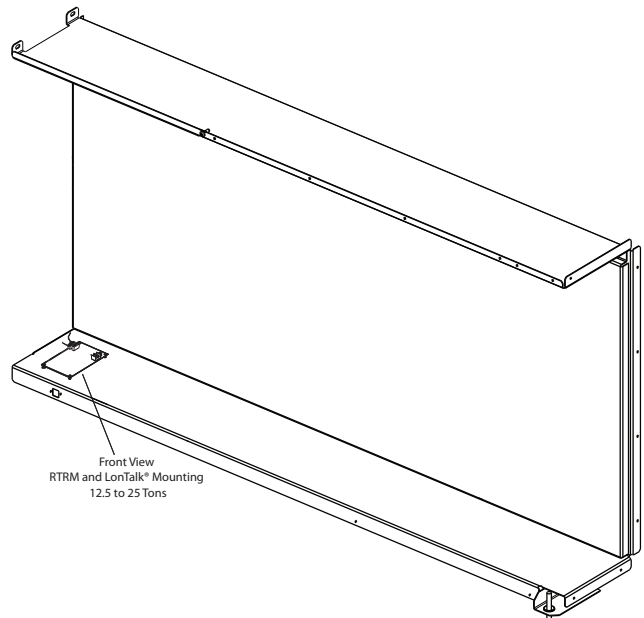

**Figure 4. LonTalk® communication interface board mounting and wiring - Y/T/WHC120\* units**

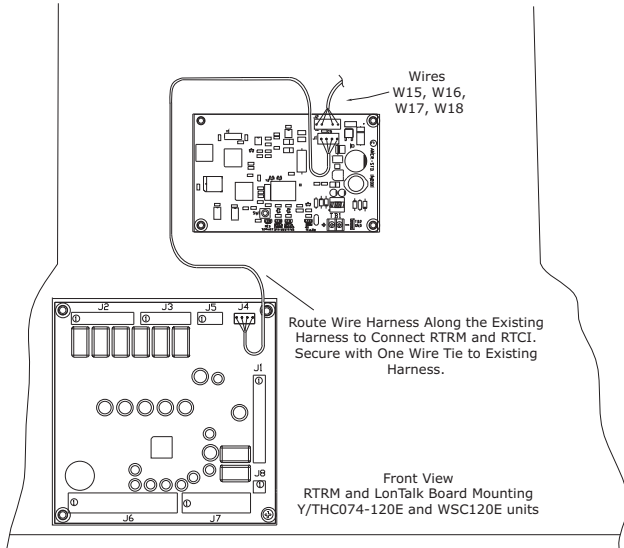

For units with optional separation of voltage:

- If RTAM is present, disconnect PPF34 (wires 642A, 643A, 644A, and 645A) from J4 on the RTRM and connect it to J2 on the LCI module.
- If VSM is present, disconnect PPF33 (wires W128, W129, W130, and W131) from J4 on the RTRM and connect it to J2 on the LCI module.
- If RTAM and VSM are not present, disconnect PPF5 (wires 638A, 639A, 640A, and 641A) from the J4 on the RTRM and connect it to J2 on the LCI module.
- Using the harness supplied in the kit, connect one end of the harness to J1 on the LCI module and the other end to J4 on the RTRM.

**Figure 5. LonTalk® Communication Interface board mounting and wiring: 4 to 5 ton Precedent™ high efficiency, 17 Plus and 5 ton Precedent™ heat pump units, 6 to 10 ton packaged rooftop units**

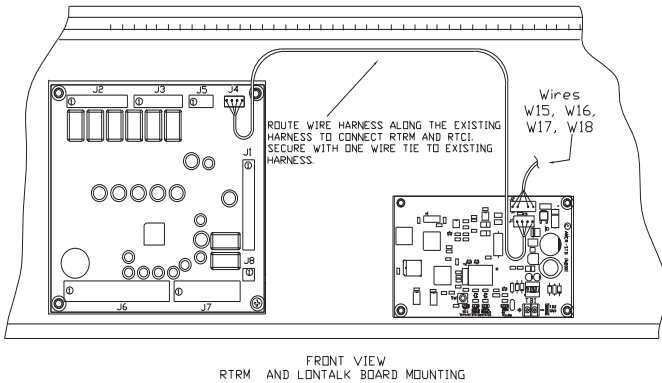

**Note:** 6-10 ton T/YZC and TSC/WSC Precedent™ Comm Board mounted in same location, except at 90° on HV/LV divider panel

**6 to 10 Tons Packaged Rooftop Units, 4 to 5 Tons Precedent™ high efficiency, 17 Plus and 5 Ton Precedent™ Heat Pump units:**

Mount the LonTalk® Communication Interface board to the right side of the ReliaTel™ Refrigeration Module mounting panel by sliding the LonTalk® Communication Interface mounting feet into the mounting extrusions (if available) on the control box mounting panel. If panel extrusions are available use 1 screw to secure, otherwise, use 2 screws to secure the board to the control box. See [Figure 5, p. 7](#) and [Figure 4, p. 7](#).



## Installation

**Figure 6. LonTalk® communication interface board mounting and wiring 3 to 5 tons packaged rooftop units (except for T/YSC033-063G, D/W\*C036-048H, 4 to 5 Tons Precedent™ high efficiency, 17 Plus and 5 Ton Precedent™ Heat Pump units) and 6 to 12.5 tons split system units**

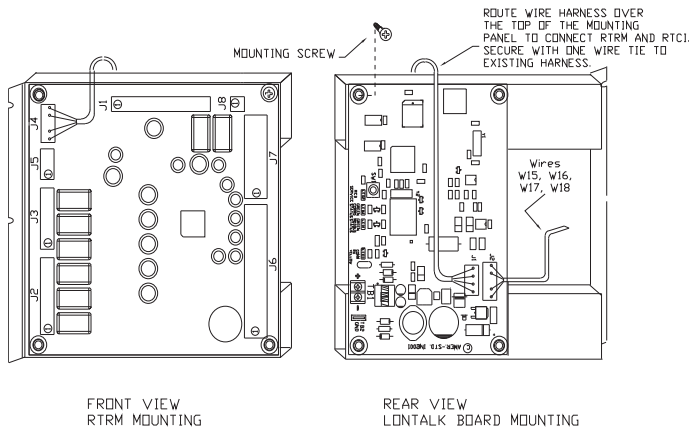

**3 to 5 Tons Packaged Rooftop (except for T/YSC033-063G, D/W\*C036-048H, 4 to 5 Tons Precedent™ high efficiency, 17 Plus and 5 Ton Precedent™ Heat Pump units) and 6 to 12.5 Tons Split System units:**

Mount the LonTalk® Communication Interface board to the rear side of the ReliaTel™ Refrigeration Module mounting panel by sliding the LonTalk® Communication Interface mounting feet into the mounting extrusions on the ReliaTel™ Refrigeration Module mounting panel. Secure with 1 screw. See [Figure 6, p. 8](#).

For T/YSC033-063G and D/W\*C036-048H, mount the LonTalk® Communication Interface to the divider panel in the control box.

**Figure 7. LonTalk® communication interface board mounting and wiring 27.5 to 50 tons packaged rooftop units**

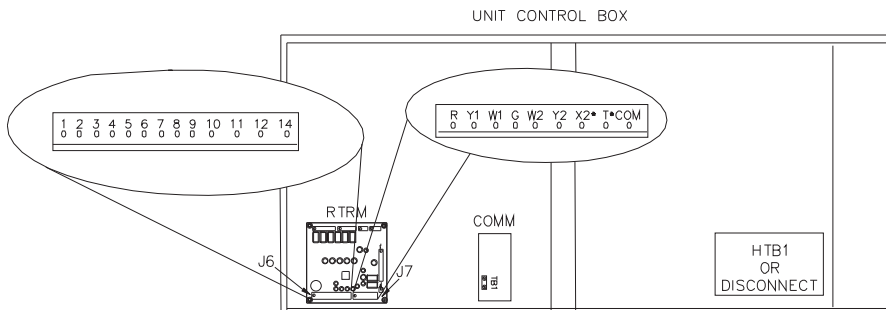

**27.5 to 50 Tons packaged rooftop units:**

Mount the LonTalk® Communication Interface board to the right side of the ReliaTel™ Refrigeration Module on the control box back panel. Secure with 4 screws. See [Figure 7, p. 8](#).

**Note:** For Split System 6 to 25 tons units, skip [Step 3](#).

3. Remove the five pin (four wire) connector from J4 on the RTRM and connect to J2 on the LonTalk® Communication Interface board.
4. Connect the four pin (four wire) end of the LonTalk® Communication Interface board wire harness to J1 on the LonTalk® Communication Interface board.
5. Connect the five pin (four wire) end of the LonTalk® Communication Interface board wire harness to J4 on the ReliaTel™ Refrigeration Module.

**Important:** On 15 to 20 tons Split System Heat Pump units only — install a new 2-Step Mechanical Heat configuration wire (68F) by following the installation instructions for BAYWRKT003\*. Once completed, proceed to [Step 6](#).

6. Route the LonTalk® Communication Interface board wire harness and secure with one wire tie.
7. Route the twisted pair communications wire from the BMS or CCP, through the hole located below TB1 on the LonTalk® Communication Interface board and connect these wires to TB1. Refer to the ICS Communications

Link Wiring Requirements section for wire information.

8. Secure the wires connected to TB1 using the pop-in wire tie under the control box.

## LonTalk® Communication Link Wiring Requirements

The LonTalk® communications link is for connection to a Building LonTalk® Network.

The Communications link wiring is dependent on the network architecture. It is recommended that a System Integrator refer to "LonWorks® FTT-10A Free Topology Transceiver User's Guide" by the Echelon Corporation for proper wire selection. The physical limits are defined in Chapter 4, Network Cabling And Connection. This User's Guide is available on the Echelon Web page. A typical wire recommendation is Belden 85102, single twisted pair, stranded 19/29, misalleged, 150°C.

### Status/Power/Wink/Test LED

(STATUS LED)



The LCI-R board includes a green Status LED located near the middle of the board. Refer to page 1 for location view. The operation for this LED is defined as follows:

- + ON - Power is applied and the LCI-R is normal.
- + OFF - There is either no power applied or the LCI-R is unconfigured or offline.
- + Blinking twice per second for 10 seconds - The LCI-R has been commanded to WINK.
- + Continuous Blinking; ON for 2.25 seconds, OFF for 0.25 seconds - The unit is in a TEST mode.

## Wink Response

The LCI-R responds to a network “Wink Request”. Upon receipt of a Wink request the LCI-R will blink (0.25 second ON, 0.25 second OFF, 0.25 second ON, etc...) the STATUS LED continuously for 10 seconds. This Wink response is available both when the LCI-R node is configured and when it is unconfigured.

## Communication LED (COMM LED)

The LCI-R board includes a yellow COMM LED located left of the TB1 terminal. Refer to page 1 for location view. The operation for this LED is defined as follows:

- + Flickering - When communication activity is detected on the network. (This LED is not effected by transmitting data from the LCI-R.)
- + OFF - No current activity on the Network.

## Service Switch (SERVICE LED)

The LCI-R board includes a Service push-button switch (also known as Service Pin) and Service LED. The Service Switch is located on the bottom middle of the board (Refer to page 1 for location view) and may be used during configuration, installation, and maintenance of the node. The operation of the Switch button is as follows:

- + Temporary press - Broadcast Neuron ID and Program ID
- + Extended press (more than 15 seconds) - Force the node to it's unconfigured state.

**Note:** An Extended Press will disable the LCI-R completely and a network management tool will be required to put the LCI-R back into operation.

Provisions for holding the Timed Override button for 10 seconds will generate a Service Pin broadcast equal to a Service Pin temporary press.

The LCI-R board includes a red Service LED located above the Service Switch, refer to page 1 for location view. The operation for this LED is defined as follows:

State	LED Output
Normal	Steady OFF
Bad Hardware	Steady ON
Unconfigured State	Flashing 1 second ON, 1 Second OFF
Watchdog Timer Reset Occurring	Flashing 1 second ON, 1 Second OFF

The Service LED turns on while the Service pin is being depressed.

## Modbus STATUS (Modbus LED)

The LCI-R Board includes a Green COMM 4 LED located to the right of the TB2 terminal block. Refer to the images on the front cover for location view. This LED indicates communication between the LCI-R and the ReliaTel™ Control. The operation for this LED is defined as follows:

State	LED Output
Normal Operation	Steady ON
LCI-R not operating	Steady OFF
ReliaTel™ Control not responding	Flashing 0.25 seconds ON, 2.0 Seconds OFF

## Network Interface

### Network Variables

The LCI-R contains 2 objects. Object index 0 is the Node Object. Object index 1 is the Rooftop Object.

The integer in the left column for [Table 1](#) is the network variable index used for reference during binding or to perform a network variable browse.

**Table 1. Rooftop configuration property**

Index	Name	Profile	Self doc string
62	nviTraneVar2	Node Ex	\$0#3001;nviTraneVar2
63	nviApplicMode	DAC	@2 3;nviApplicMode
64	nviApplicMode	SCC	@1 8;nviApplicMode
65	nviAuxHeatEnable	SCC	@1 12;nviAuxHeatEnable
66	nviBldgStaticSP	DAC	@2 14;nviBldgStaticSP
67	nviBldgStaticSP	SCCX	@1#4043;nviBldgStaticSP
68	nviBldgStatPress	DAC	@2 13;nviBldgStatPress
69	nviBldgStatPress	SCCX	@1#4009;nviBldgStatPress
70	nviComprEnable	SCC	@1 11;nviComprEnable
71	nviDACISP	DAC	@2 7;nviDACISP
72	nviDACISP	SCCX	@1#4067;nviDACISP
73	nviDAHTSP	DAC	@2 8;nviDAHTSP
74	nviDAHTSP	SCCX	@1#4068;nviDAHTSP
75	nviDAReheatSP	DACX	@2#4013;nviDAReheatSP
76	nviDAReheatSP	SCCX	@1#4044;nviDAReheatSP
77	nviDehumEnable	DAC	@2 30;nviDehumEnable
78	nviDehumEnable	SCCX	@1#4045;nviDehumEnable
79	nviDuctStaticSP	DAC	@2 6;nviDuctStaticSP
80	nviEconEnable	DAC	@2 17;nviEconEnable
81	nviEconEnable	SCC	@1 13;nviEconEnable

## Installation

**Table 1. Rooftop configuration property (continued)**

Index	Name	Profile	Self doc string
82	nviEmergOverride	DAC	@2 4;nviEmergOverride
83	nviEmergOverride	SCC	@1 17;nviEmergOverride
84	nviFanModeCmd	Prod Ex	\$0#6002;nviFanModeCmd
85	nviHeatCool	SCC	@1 9;nviHeatCool
86	nviMinOAFLOWSP	DAC	@2 19;nviMinOAFLOWSP
87	nviOAMinPos	DAC	@2 18;nviOAMinPos
88	nviOAMinPos	SCC	@1 59;nviOAMinPos
89	nviOccManCmd	DAC	@2 2;nviOccManCmd
90	nviOccManCmd	SCC	@1 6;nviOccManCmd
91	nviOccSchedule	DAC	@2 1;nviOccSchedule
92	nviOccSchedule	SCC	@1 5;nviOccSchedule
93	nviOccSensor	SCC	@1 7;nviOccSensor
94	nviOutdoorRH	DAC	@2 21;nviOutdoorRH
95	nviOutdoorRH	SCC	@1 21;nviOutdoorRH
96	nviOutdoorTemp	DAC	@2 20;nviOutdoorTemp
97	nviOutdoorTemp	SCC	@1 19;nviOutdoorTemp
98	nviPriCoolEnable	DAC	@2 15;nviPriCoolEnable
99	nviPriHeatEnable	DAC	@2 16;nviPriHeatEnable
100	nviRequest	Node	@0 1;nviRequest
101	nviServiceTest	Prod Ex	\$0#6004;nviServiceTest
102	nviSetpoint	SCC	@1 2;nviSetpoint
103	nviSetptOffset	SCC	@1 3;nviSetptOffset
104	nviSpaceCO2	DACX	@2#4006;nviSpaceCO2
105	nviSpaceCO2	SCC	@1 22;nviSpaceCO2
106	nviSpaceDehumSP	DAC	@2 31;nviSpaceDehumSP
107	nviSpaceDehumSP	SCCX	@1#4047;nviSpaceDehumSP
108	nviSpaceRH	DAC	@2 27;nviSpaceRH
109	nviSpaceRH	SCC	@1 20;nviSpaceRH
110	nviSpaceTemp	DAC	@2 26;nviSpaceTemp
111	nviSpaceTemp	SCC	@1 1;nviSpaceTemp
112	nviTraneVar1	SCCX	\$1#4001;nviTraneVar1
113	nvoAlarmMessage	Node Ex	@0#3003;nvoAlarmMessage
114	nvoApplicMode	DAC	@2 41;nvoApplicMode
115	nvoBldgStatPress	DAC	@2 54;nvoBldgStatPress
116	nvoBldgStatPress	SCCX	@1#4012;nvoBldgStatPress
117	nvoDAREheatSP	DACX	@2#4011;nvoDAREheatSP
118	nvoDAREheatSP	SCCX	@1#4050;nvoDAREheatSP
119	nvoDehumidifier	DAC	@2 73;nvoDehumidifier
120	nvoDehumidifier	SCCX	@1#4051;nvoDehumidifier
121	nvoDischAirTemp	DAC	@2 35;nvoDischAirTemp
122	nvoDischAirTemp	SCC	@1 34;nvoDischAirTemp
123	nvoDuctStatPress	DAC	@2 38;nvoDuctStatPress
124	nvoEconEnabled	DAC	@2 55;nvoEconEnabled
125	nvoEffDATempSP	DAC	@2 37;nvoEffDATempSP
126	nvoEffDATempSP	SCCX	@1#4069;nvoEffDATempSP
127	nvoEffDuctStatSP	DAC	@2 39;nvoEffDuctStatSP
128	nvoEffectOccup	DAC	@2 42;nvoEffectOccup
129	nvoEffectOccup	SCC	@1 29;nvoEffectOccup
130	nvoEffectSetpt	SCC	@1 28;nvoEffectSetpt
131	nvoEffSpaceDHSP	DAC	@2 72;nvoEffSpaceDHSP

**Table 1. Rooftop configuration property (continued)**

Index	Name	Profile	Self doc string
132	nvoEffSpaceDHSP	SCCX	@1#4052;nvoEffSpaceDHSP
133	nvoExhFanStatus	DAC	@2 46;nvoExhFanStatus
134	nvoExhFanStatus	SCCX	@1#4011;nvoExhFanStatus
135	nvoFanSpeed	SCC	@1 33;nvoFanSpeed
136	nvoHeatCool	DAC	@2 40;nvoHeatCool
137	nvoHeatCool	SCC	@1 30;nvoHeatCool
138	nvoLoadAbsK	SCC	@1 36;nvoLoadAbsK
139	nvoMATemp	DAC	@2 65;nvoMATemp
140	nvoMATemp	SCCX	@1#4008;nvoMATemp
141	nvoMixedAirTemp	SCC	@1 64;nvoMixedAirTemp
142	nvoOADamper	DAC	@2 56;nvoOADamper
143	nvoOADamper	SCC	@1 42;nvoOADamper
144	nvoOAFLOW	DAC	@2 57;nvoOAFLOW
145	nvoOutdoorRH	DAC	@2 61;nvoOutdoorRH
146	nvoOutdoorRH	SCC	@1 44;nvoOutdoorRH
147	nvoOutdoorTemp	DAC	@2 59;nvoOutdoorTemp
148	nvoOutdoorTemp	SCC	@1 45;nvoOutdoorTemp
149	nvoRATemp	DAC	@2 67;nvoRATemp
150	nvoRATemp	SCCX	@1#4019;nvoRATemp
151	nvoServiceTest	Prod Ex	\$0#6032;nvoServiceTest
152	nvoSetpoint	SCC	@1 31;nvoSetpoint
153	nvoSpaceCO2	DACX	@2#4007;nvoSpaceCO2
154	nvoSpaceCO2	SCC	@1 46;nvoSpaceCO2
155	nvoSpaceRH	DAC	@2 68;nvoSpaceRH
156	nvoSpaceRH	SCC	@1 43;nvoSpaceRH
157	nvoSpaceTemp	DAC	@2 66;nvoSpaceTemp
158	nvoSpaceTemp	SCC	@1 26;nvoSpaceTemp
159	nvoStatus	Node	@0 2;nvoStatus
160	nvoSupFanStatus	DAC	@2 43;nvoSupFanStatus
161	nvoTerminalLoad	SCC	@1 37;nvoTerminalLoad
162	nvoTraneVar7	DACX	\$2#4002;nvoTraneVar7
163	nvoTraneVar7	SCCX	\$1#4003;nvoTraneVar7
164	nvoTraneVar9	Node Ex	\$0#3002;nvoTraneVar9
165	nvoUnitStatus	DAC	@2 36;nvoUnitStatus
166	nvoUnitStatus	SCC	@1 27;nvoUnitStatus
167	nvoTraneVar1702	Prod Ex	\$0#6005;nvoTraneVar1702

## Configuration Properties

The network management read and write messages can be used to modify 7 configuration parameters.

### Exhaust Enable Position

#### Network input config SNVT\_lev\_percent nciExhStartPos

This property defines the default Power Exhaust Enable set point. The default is 25%. It is clamped to its valid range 0 to 100%. An Invalid (7FFF) will return the set point to the local value.

## Duct Static Pressure Set Point

### Network input config SNVT\_press\_p nciDuctStaticSP

This property defines the default Duct Static Pressure set point. The default is 375 Pa (1.5 In WC). It is clamped to its valid range 0 to 625 Pa (0 – 2.5 In WC). Invalid (7FFF) or out of range is interpreted as default.

## Discharge Air Cooling Set Point

### Network input config SNVT\_temp\_p nciDACISP

This property defines the default Discharge Air Control Cooling set point. The default is 12.78°C (55 °F). It is clamped to its valid range 4.44 °C to 26.67 °C (40°F to +80°F). Invalid (7FFF) or out of range is interpreted as default.

## Discharge Air Heating Set Point

### Network input config SNVT\_temp\_p nciDAHtSP

This property defines the default Discharge Air Control Heating set point. The default is Invalid (7FFF). This variable is not supported by the ReliaTel™ Controls.

**Table 2. Configuration properties**

Index	Name	Profile	Self doc string
0	nciApplication	DACX	~1,2,4\xA4,2;nciApplication
1	nciApplication	SCCX	~1,1,4\xA4,3;nciApplication
2	nciBldgStaticSP	DAC	&1,2,0\X80,193;nciBldgStaticSP
3	nciBldgStaticSP	SCCX	&1,1,4\X80,193;nciBldgStaticSP
4	nciBypassTime	DAC	&1,2,0\X80,34;nciBypassTime
5	nciBypassTime	SCC	&1,1,0\X80,34;nciBypassTime
6	nciCool	DACX	~1,2,4\XA4,9;nciCool
7	nciCool	SCCX	~1,1,4\XA4,15;nciCool
8	nciCRC	Node Ex	~0,,3\X88,1;nciCRC
9	nciDACISP	DAC	&1,2,0\X80,183;nciDACISP
10	nciDACISP	SCCX	~1,1,0\X80,183;nciDACISP
11	nciDAHtSP	DAC	&1,2,0\X80,184;nciDAHtSP
12	nciDAHtSP	SCCX	~1,1,0\X80,184;nciDAHtSP
13	nciDAReheatSP	DACX	~1,2,4\X80,17;nciDAReheatSP
14	nciDAReheatSP	SCCX	~1,1,4\X80,34;nciDAReheatSP
15	nciDaytime	DACX	~1,2,4\X80,6;nciDaytime
16	nciDaytimeTerm	DACX	~1,2,4\X80,15;nciDaytimeTerm
17	nciDevBuildNum	Node Ex	~0,,3\XA4,3;nciDevBuildNum
18	nciDeviceConfig	Node Ex	~0,,3\X80,2;nciDeviceConfig
19	nciDevMajVer	Node	&1,0,0\X84,165;nciDevMajVer
20	nciDevMinVer	Node	&1,0,0\XA4,166;nciDevMinVer
21	nciDuctStatSP	DAC	&1,2,0\X80,189;nciDuctStatSP
22	nciEconVent	DACX	~1,2,4\XA4,11;nciEconVent
23	nciEconVent	SCCX	~1,1,4\XA4,17;nciEconVent
24	nciExhaustConfig	SCCX	~1,1,4\X80,8;nciExhaustConfig
25	nciExhRet	DACX	~1,2,4\XA4,12;nciExhRet

**Table 2. Configuration properties (continued)**

Index	Name	Profile	Self doc string
26	nciExhRet	SCCX	~1,1,4\XA4,18;nciExhRet
27	nciExhStartPos	DAC	&1,2,0\X80,202;nciExhStartPos
28	nciFanConfig	SCCX	~1,1,4\X80,4;nciFanConfig
29	nciHvacType	DACX	&1,2,0\XA4,169;nciHvacType
30	nciHvacType	SCC	&1,1,0\XA4,169;nciHvacType
31	nciLocation	DAC	&1,2,0\X80,17;nciLocation
32	nciLocation	SCC	&1,1,0\X80,17;nciLocation
33	nciMinOAFlowSP	DAC	&1,2,0\X80,198;nciMinOAFlowSP
34	nciMinOAFlowSP	SCCX	&1,1,4\X80,198;nciMinOAFlowSP
35	nciMinOutTm	DAC	&1,2,0\X80,52;nciMinOutTm
36	nciMinOutTm	SCC	&1,1,0\X80,52;nciMinOutTm
37	nciModuleVersion	Node Ex	~0,,6\XA4,4;nciModuleVersion
38	nciOAFlowCalib	DAC	&1,2,0\X80,67;nciOAFlowCalib
39	nciOAFlowCalib	SCCX	&1,1,4\X80,67;nciOAFlowCalib
40	nciOAMinPos	DAC	&2,215,0\X80,23;nciOAMinPos
41	nciOAMinPos	SCC	&2,216,0\X80,23;nciOAMinPos
42	nciPersonality2	DACX	~1,2,4\X80,3;nciPersonality2
43	nciPersonality2	SCCX	~1,1,4\X80,5;nciPersonality2
44	nciPreheat	DACX	~1,2,4\XA4,8;nciPreheat
45	nciPreheat	SCCX	~1,1,4\XA4,14;nciPreheat
46	nciRcvHrtBt	DAC	&1,2,0\X80,48;nciRcvHrtBt
47	nciRcvHrtBt	SCC	&1,1,0\X80,48;nciRcvHrtBt
48	nciReheat	DACX	~1,2,4\XA4,10;nciReheat
49	nciReheat	SCCX	~1,1,4\XA4,16;nciReheat
50	nciSetpoints	DAC	&1,2,0\X80,60;nciSetpoints
51	nciSetpoints	SCC	&1,1,0\X80,60;nciSetpoints
52	nciSndHrtBt	DAC	&1,2,0\X80,49;nciSndHrtBt
53	nciSndHrtBt	SCC	&1,1,0\X80,49;nciSndHrtBt
54	nciSpaceCO2Lim	DACX	&1,2,4\X80,42;nciSpaceCO2Lim
55	nciSpaceCO2Lim	SCC	&1,1,0\X80,42;nciSpaceCO2Lim
56	nciSpaceCO2LowLm	DACX	~1,2,4\X80,18;nciSpaceCO2LowLm
57	nciSpaceCO2LowLm	SCCX	~1,1,4\X80,29;nciSpaceCO2LowLm
58	nciSpaceDehumSP	DAC	&1,2,0\X80,36;nciSpaceDehumSP
59	nciSpaceRHSetpt	SCC	&1,1,0\X80,36;nciSpaceRHSetpt
60	nciSupplyFan	DACX	~1,2,4\XA4,7;nciSupplyFan
61	nciSupplyFan	SCCX	~1,1,4\XA4,13;nciSupplyFan
62	nciEconTempEnaSP	DACX	~1,2,4\X80,199;nciEconTempEnaSP
63	nciEconTempEnaSP	SCCX	~1,1,4\X80,199;nciEconTempEnaSP
64	nciEconEnthalpyEnaSP	DACX	~1,2,4\X80,200;nciEconEnthalpyEnaSP
65	nciEconEnthalpyEnaSP	SCCX	~1,1,4\X80,200;nciEconEnthalpyEnaSP

## Installation

### Send Heartbeat

#### Network input config SNVT\_time\_sec nciSndHrtBt

This parameter defines the amount of time that expires before all bound output network variables associated with the Rooftop object are automatically updated. Network variable update messages are sent at periodic intervals. The default is 5 minutes and invalid (0x7FFF) is interpreted as zero.

Setting nciSndHrtBt = 0.0 disables the Send Heartbeat.

### Occupancy Temperature Setpoint

#### Network input config SNVT\_temp\_setpt nciSetpoints

This configuration parameter defines the space temperature setpoints for the various heat, cool and occupancy modes. The occupied and standby setpoints are defaults which can be modified by various input variables such as nviSetpoint and nviSetpointOffset. The unoccupied setpoints are always valid.

If any setpoint is out of range or they are not in the proper order the LCI-R reverts to default values. The values of the individual setpoints within nciSetpoints must be kept in descending order as follows: unoccupied\_cool, standby\_cool, occupied\_cool, occupied\_heat, standby\_heat and unoccupied\_heat.

**Table 3. Typical range and default values**

	Minimum	Maximum	Default
Unoccupied_cool	10° C	32.22° C	29.44° C
	50.00° F	90.00° F	85.00° F
Standby_cool	10° C	32.22° C	25.55° C
	50.00° F	90.00° F	78.00° F
Occupied_cool	10° C	32.22° C	23.33° C
	50.00° F	90.00° F	74.00° F
Occupied_heat	10° C	40.55° C	21.67° C
	50.00° F	105.00° F	71.00° F
Standby_heat	10° C	40.55° C	19.44° C
	50.00° F	105.00° F	67.00° F
Unoccupied_heat	10° C	40.55° C	15.55° C
	50.00° F	105.00° F	60.00° F

### Minimum Send Time

#### Network input config SNVT\_time\_sec nciMinOutTm

This parameter defines the minimum period of time which must elapse between updates of bound output network variables. The default is 2.5 seconds. An invalid value (0xFFFF) is considered the same as zero.

Setting nciMinOutTm = 0.0 disables the Minimum Send Time, allowing the LCI-R to send multiple network variable updates as fast as it can.

### Receive Heartbeat

#### Network input config SNVT\_time\_sec nciRcvHrtBt

This parameter specifies the maximum period of time which can elapse between updates to an input network variable before the LCI-R begins to use the default value. Each input network variable is monitored for updates individually. The default is 15 minutes and invalid (0xFFFF) is interpreted as zero.

Setting nciRcvHrtBt = 0.0 disables the Receive Heartbeat. The following input network variables DO NOT revert back to their defaults, they are based on Receive Heartbeat:

- nviSetpoint
- nviOccManCmd
- nviEmergOverride
- nviDAHISP
- nviDuctStaticSP
- nviDACISP
- nviOAMinPos

### Location Label

#### Network input config SNVT\_str\_asc nciLocation

This parameter, if utilized, can provide more descriptive physical location information in an ASCII string. The default is null. Default Tracer™ LCI-R ReliaTel™.

### Local Bypass Time

#### Network input config SNVT\_time\_min nciBypassTime

This parameter defines the amount of time that the LCI-R will remain in the bypass mode after receiving a bypass request. The default is 120 minutes. It is clamped to its valid range (0-240 minutes). Invalid (0xFFFF) is interpreted as zero.

If nciBypassTime = 0 then no bypass is allowed and a Bypass request is ignored.

### Outdoor Air Damper Minimum Position

#### Network input config SNVT\_lev\_percent nciOAMinPos

This parameter can be used to set the outdoor air damper minimum position. If any of the following conditions are true, the outdoor air damper minimum position is set to zero. Otherwise it is set to the value specified by nciOAMinPos. The default is invalid (0x7FFF). This sets the set point to the local value. This parameter has a range of 0-100%.

- nvoEffectOccup = OC\_UNOCCUPIED;
- nvoHeatCool = HVAC\_MRNG\_WRMUP;
- nvoHeatCool = HVAC\_PRE\_COOL;
- nvoHeatCool = HVAC\_NIGHT\_PURGE

## Space Humidity Set Point

### Network input config SNVT\_lev\_percent nciSpaceRHSetpt

This property defines the default Space Humidity set point. The default is Invalid (7FFF). It is clamped to its valid range 45 to 65%. However, 0 is also a legal value that can be used to disable the dehumidification/reheat function. An Invalid (7FFF) will return the set point to the local value.

## Space CO<sub>2</sub> Limit

### Network input config SNVT\_lev\_percent nciSpaceCO<sub>2</sub>Lim

This property defines the default Space CO<sub>2</sub> limit. The default is Invalid (FFFF). It is clamped to its valid range 500 to 2000 PPM. However, 0 is also a legal value that can be used to disable the CO<sub>2</sub> function. An Invalid (FFFF) will return the set point to the local value. Default to 1000.

## Node Object

A LonMark® compatible Node Object is required to access configuration parameters using network management read and write memory messages. The Node Object (object index 0) has three network variables:

NV Index	SNVT Type	NV Name
1	SNVT_obj_request	nviRequest
2	SNVT_obj_status	nvoStatus
39	SNVT_address	nvoFileDirectory

The LonMark® object model enables a different node to send a request to an object in the LCI-R node. While the Node Object itself does not support requests via nviRequest, the Rooftop Object does. The Node Object is responsible for managing all request / response activity.

The Rooftop Object (object index 1) supports four request modes:

**RQ\_NORMAL.** The object will always be in the normal state but a request to enter the normal state is not considered an error.

**RQ\_UPDATE\_STATUS.** The Rooftop object supports the following 2 optional status flags in SNVT\_obj\_status.

**out\_of\_service** is zero if the LCI-R and the ReliateI™ Control are successfully communicating. Otherwise it is one.

**in\_alarm** is one if out\_of\_service is zero (LCI-R and ReliateI™ Control are communicating) and nvoUnitStatus.in\_alarm indicates an alarm. Otherwise it is zero.

**RQ\_REPORT\_MASK.** The two supported status bits listed above are set to one. All others are set to zero.

**RQ\_CLEAR\_ALARM.** This request will initiate a reset of the ReliateI™ Control.

If communications with the ReliateI™ module has failed, the request will remain pending until it is honored or the LCI-R node resets.

The output nvoStatus is updated and propagated whenever an update to nviRequest is received regardless of whether or not the request or ID is valid. The nvoStatus is only updated when an update to nviRequest occurs. If the nviRequest is polled, it is not guaranteed to return valid data.

nvoFileDirectory (SNVT\_address) enables a network management tool to access the Configuration Parameter Template and Value Files.

## Self-Documentation

### Network Variable Optional documentation

The optional part (after the semicolon) of the network variable self-documentation string contains the name of the SNVT as defined in the template.

For example: “@1|5;nviOccSchedule”

### Optional Node Self-documentation

Contains the name.

For example: “ReliateI™ LCI-R”

### Standard Program ID

Device Class = 8,000

Trane Manufacturer ID = 42

Subclass = 3/4 (Commercial usage/FTT-10 xcvr)

Model Number = 2

### Default Address

The LCI-R will be initially programmed to be configured with a valid address in the second domain table slot (index 1). The first slot will be unused. The default address is:

Domain id: 0 (“zero length domain”)

Subnet number:1

Node number: 1

## Network Variable Descriptions:

Network Variable description NV refers to the network number of a defining profile or Trane extension.

### NV#6 Duct Static Pressure Set Point

#### Network input SNVT\_press\_p nviDuctStaticSP

This input network variable is used to allow the duct static pressure set point to be changed via the network. If a valid value is not present, either a local set point or appropriate set point as configured in nciDuctStaticSP will be used. Refer to Effective Duct Static Pressure Set Point (nvoEffDuctStatSP) for more information.

## Installation

---

### Valid Range

The valid range is 0 Pa to 625 Pa (0 to 2.5 inWc). The value 0x7FFF (32767) will be handled as an invalid value.

### Default Value

Default Value is INVALID (0x7FFF or 32767). This value will be adopted at power-up and in case of not receiving an update within the specified heartbeat time.

### NV#7 Discharge Air Cooling Set Point

#### Network input SNVT\_temp\_p nviDACISP

This input network variable is used to allow the discharge air cooling set point to be changed via the network. If a valid value is not present, either a local set point or appropriate set point as configured in nciDACISP will be used. Refer to Effective Discharge Air Temperature Set Point (nvoEffDATempSP) for more information.

### Valid Range

The valid range is 4.44 °C to 26.67 °C (40°F to +80°F). The value 0x7FFF=+327.67C will be handled as an invalid value.

### Default Value

Default Value is INVALID (0x7FFF or +327.67). This value will be adopted at power-up and in case of not receiving an update within the specified heartbeat time.

### NV#8 Discharge Air Heating Set Point

#### Network input SNVT\_temp\_p nviDAHtSP

This input network variable is used to allow the discharge air Heating set point to be changed via the network. This variable is not supported by the ReliaTel™ Controls.

This network variable does not follow the Discharge Controller Profile Template. Unit does not have a DAC NV number.

### Effect Discharge Air Temperature Set Point

#### Network output SNVT\_temp\_p nvoEffDATempSP

This output network variable is used to monitor the effective discharge air temperature set point that the ReliaTel™ control is using for control. If the nviDACISP has a valid value, this output will echo the value of the input. If a valid value for nviDACISP does not exist, the ReliaTel™ control will use the nciDACISP value.

### Valid Range

The valid range is 4.4 °C to 26.6 °C (40 °F to +80 °F).

### When Transmitted

This variable is transmitted immediately when its value has changed significantly. Additionally, this network variable will also be transmitted as a heartbeat output on

a regular basis as dictated by the Maximum Send Time (nciSndHrtBt) configuration value.

### Update Rate

This value will be updated no faster than the Minimum Send Time (nciMinOutTm) configuration value.

### Default Service Type

The default service type is unacknowledged.

### Effect Duct Static Pressure

#### Network output SNVT\_press\_p nvoEffDuctStatPress

This output network variable indicates the duct static in Pa, if the unit has a locally wired duct static sensor.

### Valid Range

The valid range is 0 Pa to 1250 Pa (0 to 5 inWc). The value 0x7FFF=+32767 Pa will be sent as an invalid value to indicate that the locally wired duct sensor is failed.

### When Transmitted

This variable is transmitted immediately when its value has changed significantly. Additionally, this network variable will also be transmitted as a heartbeat output on a regular basis as dictated by the Maximum Send Time (nciSndHrtBt) configuration value.

### Update Rate

This value will be updated no faster than the Minimum Send Time (nciMinOutTm) configuration value.

### Default Service Type

The default service type is unacknowledged.

### Effect Duct Static Pressure Set Point

#### Network output SNVT\_press\_p nvoEffDuctStatSP

This output network variable is used to monitor the effective duct static pressure set point that the ReliaTel™ control is using for control. If the nviDuctStaticSP has a valid value, this output will echo the value of the input. If a valid value for nviDuctStaticSP does not exist, the ReliaTel™ control will use the nciDuctStaticSP value.

### Valid Range

The valid range is 0 Pa to 625 Pa (0 to 2.5 inWc).

### When Transmitted

This variable is transmitted immediately when its value has changed significantly. Additionally, this network variable will also be transmitted as a heartbeat output on a regular basis as dictated by the Maximum Send Time (nciSndHrtBt) configuration value.

**Update Rate**

This value will be updated no faster than the Minimum Send Time (nciMinOutTm) configuration value.

**Default Service Type**

The default service type is unacknowledged.

**Application Mode**

**Network output SNVT\_hvac\_mode  
nvoApplicMode**

This output network variable is used to control the mode of other controllers, such as VAV box controllers.

**Valid Range**

**Outputs**

- nvoApplicMode
- HVAC\_AUTO
- HVAC\_COOL
- HVAC\_MAX\_HEAT

**When Transmitted**

This variable is transmitted immediately when its value has changed significantly. Additionally, this network variable will also be transmitted as a heartbeat output on a regular basis as dictated by the Maximum Send Time (nciSndHrtBt) configuration value.

**Update Rate**

This value will be updated no faster than the Minimum Send Time (nciMinOutTm) configuration value.

**Default Service Type**

The default service type is unacknowledged.

**Supply Fan Status**

**Network output SNVT\_switch  
nvoSupFanStatus**

This output network variable indicates the supply fan status mode echoed back from the ReliaTel™ Control.

**Valid Range**

State Value Equivalent

**Percent**

Actual or Requested

**Supply Fan State**

- 0 N/A 0.0% OFF
- 1 1 to 200 1.0 % to 100% ON

**When Transmitted**

This variable is transmitted immediately when its value has changed significantly. Additionally, this network variable will also be transmitted as a heartbeat output on

a regular basis as dictated by the Maximum Send Time (nciSndHrtBt) configuration value.

**Update Rate**

This value will be updated no faster than the Minimum Send Time (nciMinOutTm) configuration value.

**Default Service Type**

The default service type is unacknowledged.

**Exhaust Fan Status**

**Network output SNVT\_switch  
nvoExhFanStatus**

This output network variable indicates the supply fan status mode echoed back from the ReliaTel™ Control.

**Valid Range**

State Value Equivalent

**Percent**

Actual or Requested

**Exhaust Fan State**

- 0 N/A 0.0% OFF
- 1 1 to 200 1.0 % to 100% ON

**When Transmitted**

This variable is transmitted immediately when its value has changed significantly. Additionally, this network variable will also be transmitted as a heartbeat output on a regular basis as dictated by the Maximum Send Time (nciSndHrtBt) configuration value.

**Update Rate**

This value will be updated no faster than the Minimum Send Time (nciMinOutTm) configuration value.

**Default Service Type**

The default service type is unacknowledged.

**Economizer Enabled**

**Network output SNVT\_switch  
nvoEconEnabled**

This output network variable indicates the economizer enable status mode echoed back from the ReliaTel™ Control.

**Valid Range**

State Value Equivalent

**Percent**

Economizer

**Mode**

- 0 N/A 0.0% Disabled
- 1 200 100.0% Enabled



## Installation

---

### When Transmitted

This variable is transmitted immediately when its value has changed significantly. Additionally, this network variable will also be transmitted as a heartbeat output on a regular basis as dictated by the Maximum Send Time (nciSndHrtBt) configuration value.

### Update Rate

This value will be updated no faster than the Minimum Send Time (nciMinOutTm) configuration value.

### Default Service Type

The default service type is unacknowledged.

### Supply Fan Status

Network output SNVT\_switch nvoSupFanStatus

This output network variable indicates the supply fan status mode echoed back from the ReliaTel™ Control.

### Valid Range

State Value Equivalent

### Percent

Actual or Requested

### NV#1 Space Temperature Input

#### Network input SNVT\_temp\_p nviSpaceTemp;

This input network variable is used to connect an external space temperature sensor to the LCI-R. It does not have to be bound to a sensor node if the unit has a locally wired space temperature sensor. In any case, the nviSpaceTemp has priority if a valid value is present.

### Valid Range

The valid range is -40°C to 65.5°C (-40°F to 149.9°F). The value 0x7FFF=+327.67°C will be handled as an invalid value.

### Default Value

Default Value is 0x7FFF (=+327.67°C). This value will be adopted at power-up and in case of not receiving an update within the specified receive heartbeat time.

### NV#2 Temperature Setpoint Input (absolute)

#### Network input SNVT\_temp\_p nviSetpoint;

This input network variable is used to allow the temperature setpoints for the occupied and standby modes to be changed via the network.

**Note:** *The unoccupied setpoints are not changed.*

If a valid value is not present, either a locally wired setpoint knob or the appropriate setpoint as configured in nciSetpoints will be used. Refer to Effective Setpoint Output (nvoEffectSetpt) for more information.

### Valid Range

The valid range is 10°C to 35°C (50° F to 95°F). The value 0x7FFF=+327.67°C will be handled as an invalid value.

### Default Value

The default Value is 0x7FFF (= +327.67°C). This value will be adopted at power-up. When the default value is in effect, the ReliaTel™ module will use the configuration property nciSetpoints. This network variable input does not use the Receive Heartbeat function.

### NV#3 Setpoint Offset Input

#### Network input SNVT\_temp\_p nviSetptOffset;

This input network variable is used to shift the effective occupied and standby temperature setpoints by adding nviSetptOffset to the current setpoints. (Note: The unoccupied setpoints are not changed.) It is typically bound to a supervisory node or to an external module having a relative setpoint adjustment. All occupied and standby setpoints will be shifted upward (+) or downward (-) by the value of nviSetptOffset. Refer to Effective Setpoint Output (nvoEffectSetpt) for more information.

### Valid Range

The valid range is -10°C to +10°C. The value 0x7FFF (interpreted as 0) will be handled as an invalid value.

### Default Value

The default Value is 0° C to disable the setpoint offset. This value will be adopted at power-up and in case of not receiving an update within the specified receive heartbeat time.

### NV#5 Occupancy Scheduler Input

#### Network input SNVT\_tod\_event nviOccSchedule;

This input network variable is used to command the Voyager into different occupancy modes. It is typically sent by a scheduler or a supervisory node. SNVT\_tod\_event is a structure containing three parts. Only the current\_state is used for this network variable input. This input is used in conjunction with nviOccManCmd and nviOccSensor (if provided) to determine the effective occupancy mode. Refer to Effective Occupancy Output (nvoEffectOccup) for more information.

### Valid Range

For current\_state:

0 = OC\_OCCUPIED: The ReliaTel™ Control should operate in the occupied mode (e.g. occupied setpoint).

1 = OC\_UNOCCUPIED: The ReliaTel™ Control should operate in the unoccupied mode (e.g. unoccupied setpoint and fan mode in AUTO).

2= OC\_BYPASS: The ReliaTel™ Control should operate in the occupied mode for a period of time defined by nciBypassTime

3 = OC\_STANDBY: The ReliaTel™ Control should operate in the standby mode (e.g. standby setpoint).

4 to FF = OC\_NUL: This is the initial value after power-up and it remains until another value is received. It is used to indicate that this network variable input is invalid or unused.

All other enumerations are ignored, the previous valid update is used.

### Default Value

Current\_state = 0xFF = OC\_NUL

This value will be adopted at power-up and in case of not receiving an update within the specified Receive Heartbeat time.

### NV#6 Occupancy Override Input

#### Network input SNVT\_occupancy nviOccManCmd;

This input network variable is used to command the ReliaTel™ Control into different occupancy modes. It is typically sent by an externally mounted occupant-interface module or a supervisory node, to manually control occupancy modes, or to override the scheduled occupancy.

The bypass timer is started when an update to nviOccManCmd occurs in which nviOccManCmd = OC\_BYPASS. There is no Receive Heartbeat associated with nviOccManCmd, so any update in which nviOccManCmd = OC\_BYPASS will restart the bypass timer. Any other update will clear the bypass timer. When the timer expires, nviOccManCmd reverts to OC\_NUL.

This input is used in conjunction with nviOccSchedule and nviOccSensor (if provided) to determine the effective occupancy mode. Refer to Effective Occupancy Output (nvoEffectOccup) for more information.

### Valid Range

0 = OC\_OCCUPIED: The ReliaTel™ Control should operate in the occupied mode (e.g. occupied setpoint).

1 = OC\_UNOCCUPIED: The ReliaTel™ Control should operate in the unoccupied mode (e.g. unoccupied setpoint and fan mode in AUTO).

2 = OC\_BYPASS: The ReliaTel™ Control should operate in the occupied mode for a period of time defined by nciBypassTime.

3 = OC\_STANDBY: The ReliaTel™ Control should operate in the standby mode (e.g. standby setpoint).

0xFF = OC\_NUL: This is the initial value after power-up and it remains until another value is received. It is used to indicate that this network variable input is invalid or unused, or to cancel a previous command.

### Default Value

The default value OC\_NUL = 0xFF.

This value will be adopted at power-up. This network variable input does not use the Receive Heartbeat function.

### NV#7 Occupancy Sensor Input

#### Network input SNVT\_occupancy nviOccSensor;

This input network variable is used to indicate the presence of occupants in the controlled space. It is typically sent by an occupancy sensor.

This input is used in conjunction with nviOccSchedule and nviOccManCmd (if provided) to determine the effective occupancy mode. Refer to Effective Occupancy Output (nvoEffectOccup) for more information.

### Valid Range

0 = OC\_OCCUPIED: The occupancy sensor is indicating that there ARE occupants in the space.

1 = OC\_UNOCCUPIED: The occupancy sensor is indicating that there are NO occupants in the space.

### Default Value

The default value is OC\_OCCUPIED = 0.

This value will be adopted at power-up and in case of not receiving an update within the specified Receive Heartbeat time.

### NV# 8 Application Mode Input

#### Network input SNVT\_hvac\_mode nviApplicMode;

This network variable input is used to coordinate the ReliaTel™ Control with any supervisory controller. If a mode is requested that is not supported by the ReliaTel™ Control, the ReliaTel™ Control will ignore the request.

The nviApplicMode overrides nviHeatCool, unless nviApplicMode is HVAC\_AUTO, HVAC\_TEST, or HVAC\_NUL. If nviApplicMode is HVAC\_AUTO, HVAC\_TEST or HVAC\_NUL, then nviHeatCool determines the effective mode of the unit. Refer to Effective Heat/Cool Output (nvoHeatCool) for more information.

### Valid Range

0 = HVAC\_AUTO (Mode determined by ReliaTel™ Control)

1 = HVAC\_HEAT (Use heat setpoints)

2 = HVAC\_MRNG\_WRMUP (Morning warmup)

3 = HVAC\_COOL (Use cool setpoints)

4 = HVAC\_NIGHT\_PURGE (Free cooling)

5 = HVAC\_PRE\_COOL (Morning cooldown)

6 = HVAC\_OFF (No unit operation allowed)

## Installation

- 7 = HVAC\_TEST (same as HVAC\_NUL)
- 8 = HVAC\_EMERG\_HEAT (Emergency heat)
- 9 = HVAC\_FAN\_ONLY (No heating or cooling allowed)
- 10 = HVAC\_FREE\_COOL
- 11 = HVAC\_ICE\_MAKING
- 12 = HVAC\_MAX\_HEAT (Same as HVAC\_HEAT)
- 13 = HVAC\_ECONOMIZE
- 14 = HVAC\_DEHUMID (Same as HVAC\_AUTO)
- 15 = HVAC\_CALIBRATE
- 0xFF = HVAC\_NUL (same as HVAC\_AUTO)

All other enumerations will be ignored.

### Default Value

The default value is HVAC\_AUTO.

This value will be adopted at power-up and in case of not receiving an update within the specified Receive Heartbeat time.

## NV#9 Heat/Cool Mode Input

### Network input SNVT\_hvac\_mode nviHeatCool;

This network variable input is used to coordinate the ReliaTel™ Control with any node that may need to control the heat/cool changeover of the unit. For example, one node may coordinate it's heat/ cool mode with another node serving the same area, or the heat/cool mode could be manually selected from a human interface device. If a mode is requested that is not supported by the ReliaTel™ Control, the ReliaTel™ Control will ignore the request.

This input is overridden by nviApplicMode, unless nviApplicMode is HVAC\_AUTO, HVAC\_TEST, or HVAC\_NUL. If nviApplicMode is HVAC\_AUTO or HVAC\_NUL or HVAC\_TEST, then nviHeatCool determines the effective mode of the unit. Refer to Effective Heat/Cool Output (nvoHeatCool) for more information.

### Valid Range

- 0 = HVAC\_AUTO (Mode determined by ReliaTel™ Control)
- 1 = HVAC\_HEAT (Use heat setpoints)
- 2 = HVAC\_MRNG\_WRMUP (Morning warm-up)
- 3 = HVAC\_COOL (Use cool setpoints)
- 4 = HVAC\_NIGHT\_PURGE (Free cooling)
- 5 = HVAC\_PRE\_COOL (Morning cool down)
- 6 = HVAC\_OFF (No unit operation allowed)
- 7 = HVAC\_TEST (Same as HVAC\_NUL)
- 8 = HVAC\_EMERG\_HEAT (Emergency heat)
- 9 = HVAC\_FAN\_ONLY (No heating or cooling allowed)
- 10 = HVAC\_FREE\_COOL (HVAC\_AUTO)
- 11 = HVAC\_ICE\_MAKING (HVAC\_AUTO)

- 12 = HVAC\_MAX\_HEAT (same as HVAC\_HEAT)
- 13 = HVAC\_ECONOMIZE (HVAC\_AUTO)
- 14 = HVAC\_DEHUMID (same as HVAC\_AUTO)
- 15 = HVAC\_CALIBRATE (HVAC\_AUTO)
- 0xFF = HVAC\_NUL (same as HVAC\_AUTO)

All other enumerations will be ignored.

### Default Value

The default value is HVAC\_AUTO.

This value will be adopted at power-up and in case of not receiving an update within the specified Receive Heartbeat time.

## Fan Mode Command

### Network input SNVT\_switch nviFanModeCmd;

This network variable does not follow the Space Comfort Controller Functional ProfileTemplate, so it does not have a SCC NV number.

This input is used to change the fan mode of the unit. The input is typically sent from a supervisory controller. This variable does not use Receive Heartbeat.

nviFanModeCmd					
nvoEffect Occup	nvoHeatC ool	State	Value	Equiv. %	Voyager Fan Mode
X	HVAC_OFF	X	X		AUTO
X	HVAC_FAN _ONLY	X	X		ON
OC_UNOCC UPIED	X	X	X		AUTO
*	X	0	n/a	n/a	AUTO
*	X	1	0	0%	AUTO
*	X	1	1 to 255	0.5% to 100%	ON
*	X	0xFF	n/a	n/a	ON

\* OC\_OCCUPIED, OC\_STANDBY, OC\_BYPASS, or OC\_NUL.

Unit Fan Mode:

-ON - Fan runs continuously

-AUTO - Fan cycles as required by Voyager

Illegal updates (states) are discarded.

### Default Value

Default value is ON (state = 0xFF) for Occupied Mode.

The value is AUTO for Unoccupied Mode.

## NV#11 Compressor Enable Input

### Network input SNVT\_switch nviComprEnable;

This input is used to disable compressor operation. The input is typically sent from a supervisory controller.

This input can be used for simple enable/disable functions, or can be used to enable a portion of the unit's compressor capacity. For example, if a unit has 2 compressors, a value

of 100 (50.0%) could indicate that only one compressor is enabled.

### Valid Range

The action initiated by this input depends upon the number of compressors in the unit.

# of Compressors	nviComprEnable			# of Compressors enabled
	State	Value	Equiv. %	
1	0	n/a	n/a	0
	1	0	0%	0
	1	1 to 255	.05% to 100%	1
	0xFF	n/a	n/a	1
2/3	0	n/a	n/a	0
	1	0	0%	0
	1	01 to 100	.05% to 50%	1
	1	101 to 200	50.5% to 100%	2/3
	1	201 to 255	100%	2/3
	0xFF	n/a	n/a	2/3

### Default Value

Default Value is ENABLED (state = 0xFF).

This value will be adopted at power-up and in case of not receiving an update within the specified Receive Heartbeat time.

### NV#12 Auxiliary Heat Enable Input

#### Network input SNVT\_switch nviAuxHeatEnable;

This input is used to disable auxiliary heat operation. This input is typically sent from a system supervisor panel. For example, during peak electrical demand periods, electric heat operation could be disabled.

This input can be used for simple enable/disable functions, or can be used to enable a portion of the unit's auxiliary heat capacity. For example, if a unit has 2 stages of electric heat, a value of 100 (50.0%) could indicate that only one stage is enabled.

Heat Type	nviAuxHeatEnable			Number of Heating Stages to be enabled
	State	Value	Equiv. %	
1 Stage Electric	0	n/a	n/a	0
	1	0	0%	0
	1	1 to 255	.05% to 100%	1
	0xFF	n/a	n/a	1
2 Stage Electric	0	n/a	n/a	0
	1	0	0%	0
	1	01 to 100	.05% to 50%	1
	1	101 to 200	50.5% to 100%	2
	1	201 to 255	100%	2
	0xFF	n/a	n/a	2

Heat Type	nviAuxHeatEnable			Number of Heating Stages to be enabled
	State	Value	Equiv. %	
Gas	0	n/a	n/a	0
	1	0	0%	0
	1	1 to 255	.05% to 100%	2
	0xFF	n/a	n/a	2
Heat Pump	0	n/a	n/a	Aux Heat Disabled
	1	0	0%	Aux Heat Disabled
	1	1 to 255	*.05% to 100%	Aux Heat Enabled
	0xFF	n/a	n/a	Aux Heat Enabled

\* This does not effect the compressor of a Heat Pump in the Heat Mode, only the auxiliary heat. To turn off all Heat in a Heat Pump the Compressor Enable Input must be set to disable the compressors.

Illegal updates (states) are discarded

### Default Value

Default Value is ENABLED (state = 0xFF).

This value will be adopted at power-up and in case of not receiving an update within the specified Receive Heartbeat time.

### NV#13 Economizer Enable Input

#### Network input SNVT\_switch nviEconEnable;

This input is used to enable and disable economizer operation. This input is typically sent from a system supervisor panel to override the local economizer enable/disable decision. For this input, economizer Auto means that the ReliaTel™ Control determines economizer operation. Enabled or Disabled means that economizer operation is allowed or not allowed (respectively), overriding the local decision.

### Valid Range

nvoHeatCool	nviEconEnable			Economizer State
	State	Value	Equiv. %	
HVAC_MRNG_WRMUP	X	X		Disabled
HVAC_NIGHT_PURGE	X	X		Enabled
	X	0	n/a	Disabled
	X	1	0	Disabled
	X	1	1 to 255	0.05% to 100% Enabled
	X	0xFF	n/a	n/a Auto (Invalid)

### Default Value

Default Value is AUTO (State = 0xFF).

This value will be adopted at power-up and in case of not receiving an update within the specified Receive Heartbeat time.

### NV#17 Emergency Override Input

Network input SNVT\_hvac\_emerg nviEmergOverride;

## Installation

This input network variable is used to command the device into different emergency modes. It is typically set by a supervisory node.

### Valid Range

The valid range is described in the table below:

- 0 = EMERG\_NORMAL: Normal operation
- 1 = EMERG\_PRESSURIZE: Start the PRESSURIZE operation
- 2 = EMERG\_DEPRESSURIZE: Start the DEPRESSURIZE operation
- 3 = EMERG\_PURGE: Start the PURGE operation
- 4 = EMERG\_SHUTDOWN: SHUTDOWN all unit functions
- 5 = EMERG\_FIRE: Input from fire pull box/system. SHUTDOWN all unit functions
- 6 to FF = EMERG\_NUL: Invalid mode (same as EMERG\_NORMAL).

nviEmergOverride	Outdoor			
	Supply Fan	Air Damper	Cooling Stages	Heating Stages
EMERG_NORMAL				
EMERG_NUL	Normal Operation			
EMERG_PRESSURIZE	On	Open	0	0
EMERG_DEPRESSURIZE	Off	Closed	0	0
EMERG_PURGE	On	Open	0	0
EMERG_SHUTDOWN	Off	Closed	0	0
EMERG_FIRE	Off	Closed	0	0

### Default Value

The default value is EMERG\_NORMAL.

This value will be adopted at power-up, until an update is received. This network variable input does not use the Receive Heartbeat function.

### NV#22 Space CO<sub>2</sub> Input

This network variable does not follow the Discharge Controller Profile Template. Unit does not have a DAC NV number.

#### Network input SNVT\_ppm nviSpacelAQ;

This input network variable is used to connect an external space CO<sub>2</sub> sensor to the LCI-R. It does not have to be bound to a sensor node if the unit has a locally wired space CO<sub>2</sub> sensor. In any case, the nviSpacelAQ has priority if a valid value is present.

### Valid Range

The valid range is 0 to +2000 ppm. The value 0xFFFF (65535) will be handled as an invalid value.

### Default Value

The default Value is 0xFFFF (65535). This value will be adopted at power-up and in case of not receiving an update within the specified receive heartbeat time.

### NV#59 Outdoor Air Damper Minimum Position Input

Network input SNVT\_lev\_percent nviOAMinPos;

This input network variable is used to connect an external damper minimum position to the LCIR. It does not have to be bound to a sensor node if the unit has a local minimum position potentiometer. In any case, the nviOAMinPos has priority if a valid value is present.

nvoEffectOccup = OC\_UNOCCUPIED;  
 nvoHeatCool = HVAC\_MRNG\_WRMUP;  
 nvoHeatCool = HVAC\_PRE\_COOL;  
 nvoHeatCool = HVAC\_NIGHT\_PURGE

### Valid Range

The valid range is 0 to 100%. The value 0x7FFF will be handled as an invalid value.

### Default Value

The default Value is 0x7FFF. This value will be adopted at power-up and in case of not receiving an update within the specified receive heartbeat time.

### NV#21 Outdoor Relative Humidity Input

#### Network input SNVT\_lev\_percent nviOutdoorRH;

This input network variable is used to connect an external outdoor RH sensor to the LCI-R. It does not have to be bound to a sensor node if the unit has a locally wired space RH sensor. In any case, the nviOutdoorRH has priority if a valid value is present.

### Valid Range

The valid range is 0 to 100%. The value 0x7FFF will be handled as an invalid value.

### Default Value

The default Value is 0x7FFF. This value will be adopted at power-up and in case of not receiving an update within the specified receive heartbeat time.

### NV#19 Outdoor Temperature Input

#### Network input SNVT\_temp\_p nviOutdoorTemp;

This input network variable is used to connect an external outdoor temperature sensor to the LCI-R. It does not have to be bound to a sensor node if the unit has a locally wired space temperature sensor. In any case, the nviOutdoorTemp has priority if a valid value is present.

### Valid Range

The valid range is -40°C to 70°C (-40°F to 158°F). The value 0x7FFF=+327.67°C will be handled as an invalid value.

## Default Value

Default Value is 0x7FFF (=+327.67°C). This value will be adopted at power-up and in case of not receiving an update within the specified receive heartbeat time.

## NV#20 Space Relative Humidity Input

### Network input SNVT\_lev\_percent nviSpaceRH;

This input network variable is used to connect an external space RH sensor to the LCI-R. It does not have to be bound to a sensor node if the unit has a locally wired space RH sensor. In any case, the nviSpaceRH has priority if a valid value is present.

## Valid Range

The valid range is 0 to 100%. The value 0x7FFF will be handled as an invalid value.

## Default Value

The default Value is 0x7FFF. This value will be adopted at power-up and in case of not receiving an update within the specified receive heartbeat time.

## NV#26 Effective Space Temperature Output

### Network output SNVT\_temp\_p nvoSpaceTemp;

This output network variable is used to monitor the effective space temperature that ReliaTel™ Control is using for control. If the input nviSpaceTemp has a valid value, this output will echo the value of the input. If a valid value for nviSpaceTemp does not exist, the locally wired sensor value is used. If neither value is available, the output will send the INVALID value.

## Range

The range is -40 °C to 65.5 °C (-40 °F to 150 °F). The value 0x7FFF=+327.67°C will be used as an invalid value in case of a sensor failure.

## When Transmitted

The variable is transmitted immediately when its value has changed significantly. Additionally, this network variable will also be transmitted as a heartbeat output on a regular basis as dictated by the Maximum Send Time (nciSndHrtBt) configuration value.

## Update Rate

This value will be updated no faster than the Minimum Send Time (nciMinOutTm) configuration value.

## Default Service Type

The default service type is unacknowledged.

## NV#28 Effective Setpoint Output

### Network output SNVT\_temp\_p nvoEffectSetpt;

This output network variable is used to monitor the effective temperature setpoint currently used by the ReliaTel™ Control, which may depend on nciSetpoints, nviSetpoint, nviSetpointOffset, nvoEffectOccup, nvoHeatCool, and any local setpoint adjustment. For example, if the occupancy state is unoccupied and the heat/cool state is heat, then the effective setpoint would be equal to the unoccupied heating setpoint defined in nciSetpoints.

## Definitions:

- $abs\_setpoint\_offset = nviSetpoint - (nciSetpoints.occupied\_cool + nciSetpoints.occupied\_heat) / 2$
- $deadband\_occupied = nciSetpoints.occupied\_cool - nciSetpoints.occupied\_heat$
- $heat\_standby\_offset = nciSetpoints.occupied\_heat - nciSetpoints.standby\_heat$
- $cool\_standby\_offset = nciSetpoints.standby\_cool - nciSetpoints.occupied\_cool$

There are 6 effective setpoints which are determined by the LCI-R:

- effective\_unoccupied\_cool
- effective\_unoccupied\_heat
- effective\_occupied\_cool
- effective\_occupied\_heat
- effective\_standby\_cool
- effective\_standby\_heat

Once these setpoints are determined, the LCI-R then determines nvoEffectSetpt based on nvoEffectOccup and nvoHeatCool. Refer to Occupancy Temperature Setpoints (p. 12) under Configuration Properties for nciSetpoints range and default values.

- $effective\_unoccupied\_cool = nciSetpoints.unoccupied\_cool$
- $effective\_unoccupied\_heat = nciSetpoints.unoccupied\_heat$

## If nviSetpoint is valid:

- $effective\_occupied\_cool = nciSetpoints.occupied\_cool + abs\_setpoint\_offset + nviSetptOffset$
- $effective\_standby\_cool = nciSetpoints.standby\_cool + abs\_setpoint\_offset + nviSetptOffset$
- $effective\_occupied\_heat = nciSetpoints.occupied\_heat + abs\_setpoint\_offset + nviSetptOffset$
- $effective\_standby\_heat = nciSetpoints.standby\_heat + abs\_setpoint\_offset + nviSetptOffset$

## Installation

### If nviSetpoint is not valid there are 4 cases to consider:

- LCS = Local Zone Cooling Setpoint Input
- LHS = Local Zone Heating Setpoint Input

Case 1: LCS is valid & LHS is valid

- $effective\_occupied\_cool = LCS + nviSetptOffset$
- $effective\_standby\_cool = LCS + cool\_standby\_offset + nviSetptOffset$
- $effective\_occupied\_heat = LHS + nviSetptOffset$
- $effective\_standby\_heat = LHS - heat\_standby\_offset + nviSetptOffset$

Case 2: LCS is valid & LHS is invalid

- $effective\_occupied\_cool = LCS + nviSetptOffset$
- $effective\_standby\_cool = LCS + cool\_standby\_offset + nviSetptOffset$
- $effective\_occupied\_heat = LCS - deadband\_occupied + nviSetptOffset$
- $effective\_standby\_heat = LCS - deadband\_occupied - heat\_standby\_offset + nviSetptOffset$

Case 3: LCS is invalid & LHS is valid

- $effective\_occupied\_cool = LHS + deadband\_occupied + nviSetptOffset$
- $effective\_standby\_cool = LHS + deadband\_occupied + cool\_standby\_offset + nviSetptOffset$
- $effective\_occupied\_heat = LHS + nviSetptOffset$
- $effective\_standby\_heat = LHS - heat\_standby\_offset + nviSetptOffset$

Case 4: LCS is invalid & LHS is invalid

- $effective\_occupied\_cool = nciSetpoints.occupied\_cool + nviSetptOffset$
- $effective\_standby\_cool = nciSetpoints.standby\_cool + nviSetptOffset$
- $effective\_occupied\_heat = nciSetpoints.occupied\_heat + nviSetptOffset$
- $effective\_standby\_heat = nciSetpoints.standby\_heat + nviSetptOffset$

The effective setpoint is then defined as follows:

Occupancy Status	Mode	nvoEffectSetpoint
OCCUPIED OR BYPASS	Cool**	effective_occupied_cool
	Heat*	effective_occupied_heat
UNOCCUPIED	Cool**	effective_unoccupied_cool
	Heat*	effective_unoccupied_heat
STANDBY	Cool**	effective_standby_cool
	Heat*	effective_standby_heat

\*Heat Modes: HVAC\_HEAT, HVAC\_EMERG\_HEAT

\*\*Cool Modes: HVAC\_COOL, HVAC\_OFF, HVAC\_TEST, HVAC\_FAN\_ONLY

**Note:** There are 2 exceptions to the table above. The occupied setpoint is used in the following cases: 1. If  $nvoHeatCool = HVAC\_MRNG\_WRMUP$  Then  $nvoEffectSetpt = effective\_occupied\_heat$ . 2. If  $nvoHeatCool = HVAC\_NIGHT\_PURGE$  or  $HVAC\_PRE\_COOL$  Then  $nvoEffectSetpt = effective\_occupied\_cool$

### Range

The range is 10°C to 32.22°C (50°F to 90°F). If the nvoEffectSetpt calculates to a lower value than 10°C (50°F), the LCI-R will clamp the nvoEffectSetpt to 10°C (50°F). If the nvoEffectSetpt calculates to a higher value than 32.22°C (90°F), the LCI will clamp the nvoEffectSetpt to 32.22°C (90°F).

### When Transmitted

The variable is transmitted immediately when its value has changed significantly. Additionally, this network variable will also be transmitted as a heartbeat output on a regular basis as dictated by the Maximum Send Time (nciSndHrtBt) configuration value.

### Update Rate

This value will be updated no faster than the Minimum Send Time (nciMinOutTm) configuration value.

### Default Service Type

The default service type is unacknowledged.

## NV#27 Unit Status Output

### Network output SNVT\_hvac\_status nvoUnitStatus;

This output network variable is used to report the ReliaTel™ Control status. It combines the operating mode, the capacity of heating and cooling used and an indication if any alarms are present in the unit. SNVT\_hvac\_status allows this information to be provided in one network variable.

### Mode:

Refer to Effective Heat/Cool Output (nvoHeatCool) for additional information regarding the value reported in the mode field. The value in the mode field is the same value as the Effective Heat/Cool Output.

### Valid Range

Mode: same as nvoHeatCool

- heat\_output\_primary: 0-100%, 0xFFFF (Invalid)
- heat\_output\_secondary: 0-100%, 0xFFFF (Invalid)
- cool\_output: 0-100%, 0xFFFF (Invalid)
- econ\_output: 0-100%, 0xFFFF (Invalid)
- fan\_output: 0-100%, 0xFFFF (Invalid)
- in\_alarm: 0 Means there is no alarm. 1 Means there is an alarm.



### Heat Output Primary:

Heat Output Primary is compatible with SNVT\_lev\_percent. This value indicates the capacity of heat that is currently operating in the Unit, for the following unit types:

- +Gas Heat: Capacity of Gas Heat stages
- +Electric Heat (not Heat Pump): Capacity of Electric Heat stages.
- +Heat Pump: Capacity of Compressor Heat stages
- +Cooling Only: A value of 0xFFFF (Invalid) is sent.

Unit Type	# of Stages Operating	Heat Output Secondary
Heat Pump with	0	0%
Single Stage Aux. Heat	1	100%
Heat Pump with	0	0%
Two Stage	1	50%
Aux. Heat	2	100%
Non Heat Pump Unit	-	0xFFFF (Invalid)

### Heat Output Secondary:

Heat Output Secondary is compatible with SNVT\_lev\_percent

This value indicates the capacity of auxiliary electric heat that is currently operating in Heat Pump units. If the unit is not a Heat Pump, a value of 0xFFFF (Invalid) is sent.

Unit Type	# of Stages Operating	Heat Output Secondary
Heat Pump with	0	0%
Single Stage	1	100%
Aux. Heat		
Heat Pump with	0	0%
Two Stage	1	50%
Aux. Heat	2	100%
Non Heat Pump Unit	-	0xFFFF (Invalid)

### Cool Output:

Cool Output is compatible with SNVT\_lev\_percent

This value indicates the capacity of mechanical cooling that is currently operating in the unit. If the unit has no mechanical cooling, a value of 0xFFFF (Invalid) is sent.

Unit Type	# of Stages Operating	Cool Output
Single Stage Cooling	0	0%
	1	100%
Two Stage Cooling	0	0%
	1	50%
	2	100%
Three Stage Cooling	0	0%
	1	33%
	2	66%
Four Stage Cooling	3	100%
	1	25%
	2	50%
	3	75%
	4	100%

Unit Type	# of Stages Operating	Cool Output
Five Stage Cooling	1	24%
	2	38%
	3	62%
	4	76%
	5	100%
Modulating DX	1	VCSPD%
	2	(VCSPD% / 3) + 33%
	3	(VCSPD% / 3) + 66%
Heating Only	-	0xFFFF (Invalid)

### Econ Output

Econ Output is compatible with SNVT\_lev\_percent.

This value indicates the position (percent open) of the unit's Outdoor Air Damper (economizer). If the unit does not have an Outdoor Air Damper, a value of 0xFFFF (Invalid) is sent.

### Fan Output

Fan Output is compatible with SNVT\_lev\_percent.

This value indicates the status of the unit's Supply Fan. If the fan is off, the value is 0%. If the fan is on, the value is 100% if Inlet Guide Vanes (IGV) or Variable Frequency Drive (VFD) is not installed. If IGV or VFD is installed and the fan is on, the value will be between 1 and 100%.

### In Alarm

This value indicates whether an alarm condition currently exists in the unit. A value of 0 = No alarm exists, while a value of 1 = an alarm exists. The following alarm conditions in the ReliaTel™ Control will indicate an alarm:

- MWU Set Point Failure
- SA Reset Amount Failure
- SA Cooling Set Point Failure
- SA Reset Set Point Failure
- SA Pressure Set Point Failure
- SA Pressure Dead Band Failure
- SA Pressure Sensor Failure
- SA Duct Pressure Limit Fault
- SA Pressure PWM Fault

## Installation

---

- Maintenance Required
- Space Temp Sensor Fail (Optional)
- Outdoor Temp Sensor Fail
- Compressor 1 HPC Lockout
- Compressor 1 LPC Lockout
- Comp 1 Disable Input/LPC
- Compressor 2 HPC Lockout
- Compressor 2 LPC Lockout
- Comp 2 Disable Input/LPC
- Smoke Detector
- Heat Fail
- Dirty Filter
- Supply Fan Fail
- Emergency Stop Input
- FroStat™ Trip
- Unit Comm Fail
- Mixed Air Temp Sensor Fail (Optional)
- OA Rel Humidity Fail (Optional)
- RA Temp Sensor Fail (Optional)
- RA Rel Humidity Fail (Optional)
- Coil Temperature Sensor Fail (Heat Pump only)
- Demand Defrost Fault A (Heat Pump only)
- Demand Defrost Fault B (Heat Pump only)
- Demand Defrost Fault C (Heat Pump only)
- Demand Defrost Fault D (Heat Pump only)
- Defrost Default Mode (Heat Pump only)
- Local Cooling Setpt Failure (Optional)
- Local Heating Setpt Failure (Optional)
- Vent Override – Purge (Optional)
- Vent Override – Exhaust (Optional)
- Vent Override – Pressurize (Optional)
- External Auto / Stop (Optional)
- Freeze Stat Tripped (Optional)
- Discharge Temperature Sensor Fail (Optional)
- CO<sup>2</sup> Sensor Fail (Optional)
- CO<sup>2</sup> Setpoint Fail (Optional)
- Dehumid Sensor Failure (Optional)
- Dehumid Setpt Failure (Optional)
- Outdoor Air CFM Sensor Failure (Option)
- Outdoor Air CFM Setpt Failure (Option)
- Space Pressure Setpt Failure (Option)
- Space Pressure Sensor Failure (Optional)
- Heating High Limit Open
- Inducer Proving Switch Fail
- No Flame Sensed on Heat Call
- Flame Rollout Switch Open
- Flame Sensed w/ Gas valve Off
- Gas Heat Module Failure
- Economizer Actuator Fault
- Comp 1 Disable Input/HPC
- Comp 2 Disable Input/HPC

### When Transmitted

This variable is transmitted immediately when its value has changed significantly. Additionally, this network variable will also be transmitted as a heartbeat output on a regular basis as dictated by the Maximum Send Time (nciSndHrtBt) configuration value.

### Update Rate

This value will be updated no faster than the Minimum Send Time (nciMinOutTm) configuration value.

### Default Service Type

The default service type is unacknowledged.

### NV#29 Effective Occupancy Output

#### Network output SNVT\_occupancy nvoEffectOccup;

This output network variable is used to indicate the actual occupancy mode of the unit. This information is typically reported to a supervisory controller, or provided to another unit to coordinate the operation of multiple units. The occupancy mode is determined by a combination of optional input network variables and logic in the controller.

### Valid Range

0 = OC\_OCCUPIED: The ReliaTel™ Control should operate in the occupied mode (e.g. occupied setpoint).

1 = OC\_UNOCCUPIED: The ReliaTel™ Control should operate in the unoccupied mode (e.g. unoccupied setpoint and fan mode in Auto.).

2 = OC\_BYPASS: The ReliaTel™ Control should operate in the occupied mode for a period of time defined by nciBypassTime.

3 = OC\_STANDBY: The ReliaTel™ Control should operate in the standby mode (e.g. standby setpoints).

### When Transmitted

The variable is transmitted immediately when its value has changed. Additionally, this network variable will be transmitted as a heartbeat output on a regular basis as dictated by the Maximum Send Time (nciSndHrtBt) configuration value.

### Update Rate

This value will be updated no faster than the Minimum Send Time (nciMinOutTm) configuration value.

### Default Service Type

The default service type is unacknowledged.

**Table 4. Effective occupancy output**

<b>nviOccManCmd</b>	<b>nviOccSchedule<sup>(a)</sup></b>	<b>nviOccSensor<sup>(b)</sup></b>	<b>nvoEffectOccup</b>
OC_OCCUPIED	X <sup>(c)</sup>	X <sup>(c)</sup>	OC_OCCUPIED
OC_UNOCCUPIED	X <sup>(c)</sup>	X <sup>(c)</sup>	OC_UNOCCUPIED
OC_BYPASS <sup>(d)</sup>	OC_OCCUPIED	X <sup>(c)</sup>	OC_OCCUPIED
	OC_UNOCCUPIED	X <sup>(c)</sup>	OC_BYPASS <sup>(d)</sup>
	OC_STANDBY	X <sup>(c)</sup>	OC_BYPASS <sup>(d)</sup>
	OC_NUL	OC_OCCUPIED <sup>(b)</sup>	OC_OCCUPIED
OC_STANDBY	X <sup>(c)</sup>	OC_UNOCCUPIED	OC_BYPASS <sup>(d)</sup>
		X <sup>(c)</sup>	OC_STANDBY
OC_NUL	OC_OCCUPIED	OC_OCCUPIED <sup>(b)</sup>	OC_OCCUPIED
		OC_UNOCCUPIED	OC_STANDBY
		X <sup>(c)</sup>	OC_UNOCCUPIED
		X <sup>(c)</sup>	OC_STANDBY
OC_NUL	OC_OCCUPIED	OC_OCCUPIED <sup>(b)</sup>	OC_OCCUPIED
		OC_UNOCCUPIED	OC_UNOCCUPIED

(a) For nviOccSchedule, this refers to the "current state" field.  
 (b) For the occupancy sensor, OC\_NUL is interpreted as OC\_OCCUPIED.  
 (c) "X" = Any State  
 (d) OC\_BYPASS can be initiated by the nviOccManCmd or local sensor mounted switch. nvoEffectOccup will only be OC\_BYPASS for the duration of the Local Bypass Time (nclBypassTime), until re-initiated by an update to nviOccManCmd or local switch.

**NV#30 Effective Heat/Cool Output**

**Network output SNVT\_hvac\_mode  
nvoHeatCool**

This output network variable is used to indicate the actual heat/cool mode of the unit. This information is typically reported to a supervisory controller, or provided to another unit to coordinate the operation of multiple units. The "mode" value reported in nvoUnitStatus is the same as nvoHeatCool.

**Valid Range**

The valid range is described in the table below:

- 1 = HVAC\_HEAT (Controller is using heat setpoints)
- 2 = HVAC\_MRNG\_WRMUP (Morning warmup)
- 3 = HVAC\_COOL (Controller is using cool setpoints)
- 4 = HVAC\_NIGHT\_PURGE (Free cooling)
- 5 = HVAC\_PRE\_COOL (Morning cooldown)
- 6 = HVAC\_OFF (No unit operation allowed)
- 7 = HVAC\_TEST (See note 2 of Effective Heat/Cool Output Table)
- 8 = HVAC\_EMERG\_HEAT (Emergency heat)
- 9 = HVAC\_FAN\_ONLY (No heating or cooling allowed)
- 10 = HVAC\_FREE\_COOL
- 11 = HVAC\_ICE
- 12 = HVAC\_MAX\_HEAT (Controller is using heat setpoints)
- 13 = HVAC\_ECONOMY
- 14 = HVAC\_DEHUMID (Humidification Mode)
- 15 = HVAC\_CALIBRATE

0xFF = HVAC\_NUL

The value of nvoHeatCool is determined by the values of nviApplicMode, nviHeatCool and logic in the ReliaTel™ Control, as described in the following table.

## Installation

**Table 5. Effective heat/cool output**

<b>nviApplicMode</b>	<b>nviHeatCool</b>	<b>nvoHeatCool(a),(b)</b>
HVAC_AUTO HVAC_NUL HVAC_TEST(b)	HVAC_AUTO	Determined by ReliaTel™
	HVAC_HEAT	HVAC_HEAT
	HVAC_MRNG_WRMUP	HVAC_MRNG_WRMUP
	HVAC_COOL	HVAC_COOL
	HVAC_NIGHT_PURGE	HVAC_NIGHT_PURGE
	HVAC_PRE_COOL	HVAC_PRE_COOL
	HVAC_OFF	HVAC_OFF
	HVAC_TEST (b)	Determined by ReliaTel™
	HVAC_EMERG_HEAT	HVAC_EMERG_HEAT
	HVAC_FAN_ONLY	HVAC_FAN_ONLY
	HVAC_NUL	Determined by ReliaTel™
	HVAC_HEAT	X
HVAC_MRNG_WRMUP(c)	X(c)	HVAC_MRNG_WRMUP(c)
HVAC_COOL	X	HVAC_COOL
HVAC_NIGHT_PURGE	X	HVAC_NIGHT_PURGE
HVAC_PRE_COOL	X	HVAC_PRE_COOL
HVAC_OFF	X	HVAC_OFF
HVAC_EMERG_HEAT	X	HVAC_EMERG_HEAT
HVAC_FAN_ONLY	X	HVAC_FAN_ONLY

**Note:** nvoHeatCool will report HVAC\_DEHUMID if the ReliaTel™ Control determines it is okay to perform dehumidification. HVAC\_DEHUMID is not supported as an input.

- (a) The "mode" field of nvoUnitStatus will typically report the same value as nvo- HeatCool.  
 (b) nvoHeatCool will report HVAC\_TEST if the ReliaTel™ Control is put into the Service Test Mode locally. HVAC\_TEST is not supported as an input.  
 (c) If nviApplicMode = HVAC\_MRNG\_WRMUP and nviHeatCool = HVAC\_EMERG\_HEAT, then nvoHeatCool = HVAC\_EMERG\_HEAT

The nvoHeatCool is also used to help determine other operating parameters in the unit, including the Fan Mode, the Economizer Enable/Disable state and Economizer Minimum Position. In certain states, nvoHeatCool overrides the normal decisions for these parameters as shown in the table below:

<b>nvoHeatCool</b>	<b>Fan Mode</b>	<b>Economizer</b>	<b>Economizer Minimum Position</b>
HVAC_HEAT	nviFanModeCmd	nviEconEnable	nciOAMinPos
HVAC_COOL	nviFanModeCmd	nviEconEnable	nciOAMinPos
HVAC_MRNG_WRMUP	nviFanModeCmd	DISABLE	0
*HVAC_NIGHT_PURGE	nviFanModeCmd	ENABLE	0
HVAC_PRE_COOL	nviFanModeCmd	nviEconEnable	0
HVAC_OFF	AUTO	nviEconEnable	nciOAMinPos
HVAC_EMERG_HEAT	nviFanModeCmd	nviEconEnable	nciOAMinPos
HVAC_FAN_ONLY	ON	nviEconEnable	nciOAMinPos

1. HVAC\_NIGHT\_PURGE disables compressors allowing for free cooling.
2. Whenever the Fan is OFF the Outdoor Air Damper (Economizer) will be closed.
3. HVAC\_NIGHT\_PURGE disables compressors allowing for free cooling.
4. Whenever the Fan is OFF the Outdoor Air Damper (Economizer) will be closed.

### When Transmitted

This variable is transmitted immediately when its value has changed significantly. Additionally, this network variable will also be transmitted as a heartbeat output on a regular basis as dictated by the Maximum Send Time (nciSndHrtBt) configuration value.

### Update Rate

This value will be updated no faster than the Minimum Send Time (nciMinOutTm) configuration value.

### Default Service Type

The default service type is unacknowledged.

## NV#31 Local Setpoint Output

### Network output SNVT\_temp\_p nvoSetpoint;

This output network variable is used to monitor the space temperature setpoint if a setpoint device is locally wired. If this setpoint is not locally wired, the output will send a failed value. ReliaTel™ Control is capable of either a local cooling setpoint device, a local heating setpoint device, or both. The following table describes how nvoSetpoint is determined, based on the options installed.

Local Cooling Setpoint (LCS)	Local Heating Setpoint (LHS)	nvoHeatCool	nvoSetpoint
FAILED	FAILED	X	INVALID
FAILED	VALID	X	LHS
VALID	FAILED	X	LCS
		HVAC_HEAT	LHS
		HVAC_MRNG_WRMUP	LHS
		HVAC_EMERG_HEAT	LHS
		HVAC_COOL	LCS
VALID	VALID	HVAC_NIGHT_PURGE	LCS
		HVAC_PRE_COOL	LCS
		HVAC_OFF	LCS
		HVAC_FAN_ONLY	LCS

### Range

The range is 10 °C to 29.4 °C (50 °F to 90 °F). The value 0x7FFF=+327.67 °C will be sent as an invalid value in case of a setpoint device failure.

### When Transmitted

The variable is transmitted immediately when its value has changed significantly. Additionally, this network variable will be transmitted as a heartbeat output on a regular basis as dictated by the Maximum Send Time (nciSndHrtBt) configuration value.

### Update Rate

This value will be updated no faster than the Minimum Send Time (nciMinOutTm) configuration value.

### Default Service Type

The default service type is unacknowledged.

## NV#33 Fan Speed Output

### Network output SNVT\_switch nvoFanSpeed;

This output network variable indicates the supply fan status mode echoed back from the ReliaTel™ Control.

## Valid Range

State	Value	Equivalent Percent	Actual or Requested Fan State
0	n/a	0.0%	OFF
1	200	100.0%	ON

### When Transmitted

This variable is transmitted immediately when its value has changed. Additionally, this network variable will also be transmitted as a heartbeat output on a regular basis as dictated by the Maximum Send Time (nciSndHrtBt) configuration value.

### Update Rate

This value will be updated no faster than the Minimum Send Time (nciMinOutTm) configuration value.

### Default Service Type

The default service type is unacknowledged.

## NV#34 Discharge Air Temperature Output

### Network output SNVT\_temp\_p nvoDischAirTemp;

This output network variable is used to monitor the temperature of the air that leaves the unit, if the temperature sensor is installed.

### Range

The range is -40.00 °C to 70.00 °C (-40.00 °F to 158 °F). The value 0x7FFF=+327.67 °C will be sent as an invalid value in case of a sensor failure.

### When Transmitted

This variable is transmitted immediately when its value has changed significantly. Additionally, this network variable will also be transmitted as a heartbeat output on a regular basis as dictated by the Maximum Send Time (nciSndHrtBt) configuration value.

### Update Rate

This value will be updated no faster than the Minimum Send Time (nciMinOutTm) configuration value.

### Default Service Type

The default service type is unacknowledged.

## NV#36 Absolute Power Consumption Output

### Network output SNVT\_power\_kilo nvoLoadAbsK;

This output network variable indicates the unit power consumption.

## Installation

---

### Range

Note that nciApplication.CoolingSourceSize and nciApplication.HeatingSourceSize must be configured by an external tool. There is no way for the LCI-R to determine these values. The default for nciApplication is zero, so if it is not modified, nvoLoadAbsK is stuck at zero.

### When Transmitted

This variable is transmitted immediately when its value has changed significantly. Additionally, this network variable will also be transmitted as a heartbeat output on a regular basis as dictated by the Maximum Send Time (nciSndHrtBt) configuration value.

### Update Rate

This value will be updated no faster than the Minimum Send Time (nciMinOutTm) configuration value.

### Default Service Type

The default service type is unacknowledged.

### NV#37 Terminal Load Output

#### Network output SNVT\_lev\_percent nvoTerminalLoad;

This output reports the current heat/cool demand of the unit. Positive implies cooling. Negative implies heating. This value is estimated from the current space temp and active setpoints.

### Range

There are 4 valid values for nvoTerminalLoad: +100%, 0, -100%. The value is determined by comparing the space temp with CSP and HSP.

### When Transmitted

This variable is transmitted immediately when its value has changed significantly. Additionally, this network variable will also be transmitted as a heartbeat output on a regular basis as dictated by the Maximum Send Time (nciSndHrtBt) configuration value.

### Update Rate

This value will be updated no faster than the Minimum Send Time (nciMinOutTm) configuration value.

### Default Service Type

The default service type is unacknowledged.

### NV#42 Outdoor Air Damper Output

#### Network output SNVT\_lev\_percent nvoOADamper;

This output network variable indicates the outdoor air damper position in percent, if the unit has an economizer.

### Range

The range is 0% to 100%. The value 0xFFFF will be sent as an invalid value to indicate that the unit does not have an economizer.

### When Transmitted

This variable is transmitted immediately when its value has changed significantly. Additionally, this network variable will also be transmitted as a heartbeat output on a regular basis as dictated by the Maximum Send Time (nciSndHrtBt) configuration value.

### Update Rate

This value will be updated no faster than the Minimum Send Time (nciMinOutTm) configuration value.

### Default Service Type

The default service type is unacknowledged

### NV#43 Space Humidity Output

#### Network output SNVT\_lev\_percent nvoSpaceRH;

This output network variable is used to monitor the effective space relative humidity that the ReliaTel™ control is using. If the input nviSpaceRH has a valid value, this output will echo the value of the input. If the valid value for the nviSpaceRH does not exist, the locally wired sensor value is used. If neither value is available, the output will send the INVALID value.

### Range

The range is 0% to 100%. The value 0x7FFF = +163.835% will be sent as an invalid value to indicate that the locally wired humidity sensor is failed.

### When Transmitted

This variable is transmitted immediately when its value has changed significantly. Additionally, this network variable will also be transmitted as a heartbeat output on a regular basis as dictated by the Maximum Send Time (nciSndHrtBt) configuration value.

### Update Rate

This value will be updated no faster than the Minimum Send Time (nciMinOutTm) configuration value.

### Default Service Type

The default service type is unacknowledged.

### NV#44 Outdoor Air Humidity Output

#### Network output SNVT\_lev\_percent nvoOutdoorRH;

This output network variable is used to monitor the effective outdoor relative humidity that the ReliaTel™ control is using. If the input nviOutdoorRH has a valid value, this output will echo the value of the input. If a valid

value for nviOutdoorRH does not exist, the locally wired sensor value is used. If neither value is available, the output will send the INVALID value.

### Range

The range is 10% to 90%. The value 0x7FFF = +163.835% will be sent as an invalid value to indicate that the locally wired humidity sensor is failed.

### When Transmitted

This variable is transmitted immediately when its value has changed significantly. Additionally, this network variable will also be transmitted as a heartbeat output on a regular basis as dictated by the Maximum Send Time (nciSndHrtBt) configuration value.

### Update Rate

This value will be updated no faster than the Minimum Send Time (nciMinOutTm) configuration value.

### Default Service Type

The default service type is unacknowledged.

## NV#45 Outdoor Air Temperature Output

### Network output SNVT\_temp\_p nvoOutdoorTemp;

This output network variable is used to monitor the effective outdoor temperature that the ReliaTel™ control is using. If the input nviOutdoorTemp has a valid value, this output will echo the value of the input. If a valid value for nviOutdoorTemp does not exist, the locally wired sensor value is used. If neither value is available, the input will send the INVALID value.

### Range

The range from the unit is -40°C to 70°C (-40°F to 158°F). The value 0x7FFF = +327.67°C will be handled as an invalid value in case of a sensor failure.

### When Transmitted

This variable is transmitted immediately when its value has changed significantly. Additionally, this network variable will also be transmitted as a heartbeat output on a regular basis as dictated by the Maximum Send Time (nciSndHrtBt) configuration value.

### Update Rate

This value will be updated no faster than the Minimum Send Time (nciMinOutTm) configuration value.

### Default Service Type

The default service type is unacknowledged.

## NV#46 Space CO2 Output

### Network output SNVT\_ppm nvoSpaceCO2;

This output network variable indicates the space CO2 in ppm, if the unit has a locally wired CO2 sensor.

This network variable does not follow the Discharge Controller Profile Template. Unit does not have a DAC NV number.

### Range

The range is 0 ppm to 2000 ppm. The value 0xFFFF will be sent as an invalid value to indicate that the locally wired CO2 sensor is failed.

### When Transmitted

This variable is transmitted immediately when its value has changed significantly. Additionally, this network variable will also be transmitted as a heartbeat output on a regular basis as dictated by the Maximum Send Time (nciSndHrtBt) configuration value.

### Update Rate

This value will be updated no faster than the Minimum Send Time (nciMinOutTm) configuration value.

### Default Service Type

The default service type is unacknowledged.

## Mixed Air Temperature Output

### Network output SNVT\_temp\_p nvoMATemp;

There are (2) Mixed Air Temperature Output Headings.

This network variable does not follow the Space Comfort Controller Functional ProfileTemplate, so it does not have a SCC NV number.

This output network variable is used to monitor the mixed air temperature of the unit, if the temperature sensor is installed.

### Range

The range is 0°C to 100°C (32°F to 212°F). The value 0x7FFF = +327.67°C will be handled as an invalid value in case of a sensor failure.

### When Transmitted

This variable is transmitted immediately when its value has changed significantly. Additionally, this network variable will also be transmitted as a heartbeat output on a regular basis as dictated by the Maximum Send Time (nciSndHrtBt) configuration value.

### Update Rate

This value will be updated no faster than the Minimum Send Time (nciMinOutTm) configuration value.

### Default Service Type

The default service type is unacknowledged.



## Installation

---

### Return Air Temperature Output

#### Network output SNVT\_temp\_p nvoRATemp;

This network variable does not follow the Space Comfort Controller Functional ProfileTemplate, so it does not have a SCC NV number.

This output network variable is used to monitor the return air temperature of the unit, if the temperature sensor is installed.

#### Range

The range is 0C to 100°C (32°F to 212°F). The value 0x7FFF = +327.67°C will be handled as an invalid value in case of a sensor failure.

#### When Transmitted

This variable is transmitted immediately when its value has changed significantly. Additionally, this network variable will also be transmitted as a heartbeat output on a regular basis as dictated by the Maximum Send Time (nciSndHrtBt) configuration value.

#### Update Rate

This value will be updated no faster than the Minimum Send Time (nciMinOutTm) configuration value.

#### Default Service Type

The default service type is unacknowledged.

### NV#64 Mixed Air Temperature Output

#### Network output SNVT\_temp\_p nvoMixedAirTemp;

This output network variable is used to monitor the mixed air temperature of the unit, if the temperature sensor is installed.

#### Range

The range is 0°C to 100°C (32°F to 212°F). The value 0x7FFF = +327.67°C will be handled as an invalid value in case of a sensor failure.

#### When Transmitted

This variable is transmitted immediately when its value has changed significantly. Additionally, this network variable will also be transmitted as a heartbeat output on a regular basis as dictated by the Maximum Send Time (nciSndHrtBt) configuration value.

#### Update Rate

This value will be updated no faster than the Minimum Send Time (nciMinOutTm) configuration value.

#### Default Service Type

The default service type is unacknowledged.



Trane and American Standard create comfortable, energy efficient indoor environments for commercial and residential applications. For more information, please visit [trane.com](http://trane.com) or [americanstandardair.com](http://americanstandardair.com).

Trane and American Standard have a policy of continuous product and product data improvement and reserve the right to change design and specifications without notice. We are committed to using environmentally conscious print practices.