

Installation Instructions

High Static Drive Kit

Foundation™ Packaged Rooftop Units

15 to 25 Tons

Model Number: BAYHSDR300*
Used With: E/GCC 180-300A3,4,W
E/GDK 180-300A3,4,W

SAFETY WARNING

Only qualified personnel should install and service the equipment. The installation, starting up, and servicing of heating, ventilating, and air-conditioning equipment can be hazardous and requires specific knowledge and training. Improperly installed, adjusted or altered equipment by an unqualified person could result in death or serious injury. When working on the equipment, observe all precautions in the literature and on the tags, stickers, and labels that are attached to the equipment.

September 2024

ACC-SVN163G-EN

©2024

1

Warnings, Cautions, and Notices

Read this manual thoroughly before operating or servicing this unit. Safety advisories appear throughout this manual as required. Your personal safety and the proper operation of this machine depend upon the strict observance of these precautions.

The three types of advisories are defined as follows:

WARNING

Indicates a potentially hazardous situation which, if not avoided, could result in death or serious injury.

CAUTION

Indicates a potentially hazardous situation which, if not avoided, could result in minor or moderate injury. It could also be used to alert against unsafe practices.

NOTICE

Indicates a situation that could result in equipment or property-damage only accidents.

Important Environmental Concerns

Scientific research has shown that certain man-made chemicals can affect the earth's naturally occurring stratospheric ozone layer when released to the atmosphere. In particular, several of the identified chemicals that may affect the ozone layer are refrigerants that contain Chlorine, Fluorine and Carbon (CFCs) and those containing Hydrogen, Chlorine, Fluorine and Carbon (HCFCs). Not all refrigerants containing these compounds have the same potential impact to the environment. Trane advocates the responsible handling of all refrigerants.

Important Responsible Refrigerant Practices

Trane believes that responsible refrigerant practices are important to the environment, our customers, and the air conditioning industry. All technicians who handle refrigerants must be certified according to local rules. For the USA, the Federal Clean Air Act (Section 608) sets forth the requirements for handling, reclaiming, recovering and recycling of certain refrigerants and the equipment that is used in these service procedures. In addition, some states or municipalities may have additional requirements that must also be adhered to for responsible management of refrigerants. Know the applicable laws and follow them.

2

WARNING

Proper Field Wiring and Grounding Required!

Failure to follow code could result in death or serious injury. All field wiring MUST be performed by qualified personnel. Improperly installed and grounded field wiring poses FIRE and ELECTROCUTION hazards. To avoid these hazards, you MUST follow requirements for field wiring installation and grounding as described in NEC and your local/state/national electrical codes.

WARNING

Personal Protective Equipment (PPE) Required!

Failure to wear proper PPE for the job being undertaken could result in death or serious injury. Technicians, in order to protect themselves from potential electrical, mechanical, and chemical hazards, MUST follow precautions in this manual and on the tags, stickers, and labels, as well as the instructions below:

- Before installing/servicing this unit, technicians MUST put on all PPE required for the work being undertaken (Examples; cut resistant gloves/sleeves, butyl gloves, safety glasses, hard hat/bump cap, fall protection, electrical PPE and arc flash clothing). ALWAYS refer to appropriate Safety Data Sheets (SDS) and OSHA guidelines for proper PPE.
- When working with or around hazardous chemicals, ALWAYS refer to the appropriate SDS and OSHA/GHS (Global Harmonized System of Classification and Labeling of Chemicals) guidelines for information on allowable personal exposure levels, proper respiratory protection and handling instructions.
- If there is a risk of energized electrical contact, arc, or flash, technicians MUST put on all PPE in accordance with OSHA, NFPA 70E, or other country-specific requirements for arc flash protection, PRIOR to servicing the unit. NEVER PERFORM ANY SWITCHING, DISCONNECTING, OR VOLTAGE TESTING WITHOUT PROPER ELECTRICAL PPE AND ARC FLASH CLOTHING. ENSURE ELECTRICAL METERS AND EQUIPMENT ARE PROPERLY RATED FOR INTENDED VOLTAGE.

3

WARNING

Follow EHS Policies!

Failure to follow instructions below could result in death or serious injury.

- All Trane personnel must follow the company's Environmental, Health and Safety (EHS) policies when performing work such as hot work, electrical, fall protection, lockout/tagout, refrigerant handling, etc. Where local regulations are more stringent than these policies, those regulations supersede these policies.
- Non-Trane personnel should always follow local regulations.

WARNING

R-454B Flammable A2L Refrigerant!

Failure to use proper equipment or components as described below could result in equipment failure, and possibly fire, which could result in death, serious injury, or equipment damage.

The equipment described in this manual uses R-454B refrigerant which is flammable (A2L). Use ONLY R-454B rated service equipment and components. For specific handling concerns with R-454B, contact your local representative.

Copyright

This document and the information in it are the property of Trane, and may not be used or reproduced in whole or in part without written permission. Trane reserves the right to revise this publication at any time, and to make changes to its content without obligation to notify any person of such revision or change.

Trademarks

All trademarks referenced in this document are the trademarks of their respective owners.

Revision History

- Used with information updated to meet A2L standards.
- Updated High static kit table.

General Information

Carefully review installation instructions.

The high static kit may be used when the required CFM is not being delivered with the standard motor and sheaves due to high static pressure parameters.

Inspection

1. Unpack all components of the kit.
2. Check carefully for shipping damage. If any damage is found, report it immediately, and file a claim against the transportation company.

Installation

⚠ WARNING

Hazardous Voltage w/Capacitors!

Failure to disconnect power and discharge capacitors before servicing could result in death or serious injury.

Disconnect all electric power, including remote disconnects and discharge all motor start/run capacitors before servicing. Follow proper lockout/tagout procedures to ensure the power cannot be inadvertently energized. For variable frequency drives or other energy storing components provided by Trane or others, refer to the appropriate manufacturer's literature for allowable waiting periods for discharge of capacitors. Verify with a CAT III or IV voltmeter rated per NFPA 70E that all capacitors have discharged.

Refer to [Figure 1](#) when reading these instructions.

Figure 1.

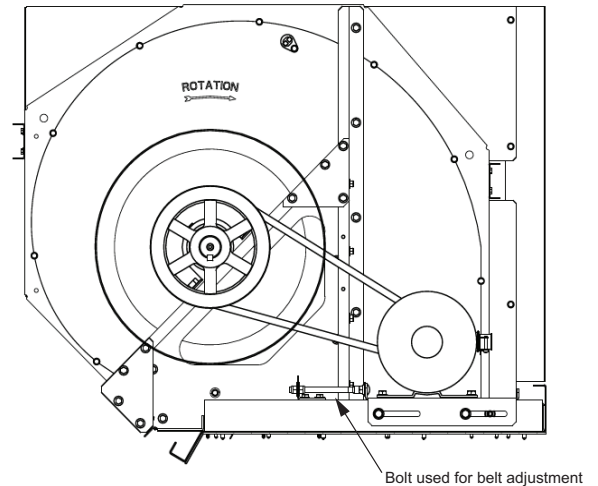

1. Confirm power to the unit has been disconnected.
2. Loosen the locknut and tension adjustment bolt on the motor plate assembly and remove the belt. See [Figure 1](#). A belt tightening instruction label is glued to the motor mounting plate.
3. Remove the existing motor sheave (for G/ECC180, G/ECC210, G/EDK180, G/EDK210) and fan sheave (for ECC300, EDK300). For G/ECC240, G/EDK240, remove both motor sheave and fan sheave.
4. Install the replacement motor sheave (for G/ECC180, G/ECC210, G/EDK180, G/EDK210) and fan sheave for (ECC300, EDK300). For G/ECC240, G/EDK240, install the replacement motor sheave and fan sheave.

5. Check the alignment between the fan and motor sheaves using a straight edge. Adjust as necessary. Torque the fan sheave set screw to 126 to 165 inch pound (14.2 to 18.6 N-m).
6. Adjust the motor sheave to the proper turns open for the required RPM to produce the desired airflow. Refer to [Table 1](#) or [Table 2](#) for the sheave data.

NOTICE

Equipment Damage!

Proper adjustment of the fan belt is important to ensure optimal unit operation. Over tightening or under tightening the fan belt can result in belt slippage and excessive wear, bearing damage, sheave misalignment, and possible failure of fan motor mounts.

7. Adjust the tension of the fan belt. The correct operating tension for a V-belt fan drive is the lowest tension at which the belt will not slip under peak load conditions. The locknut should be tightened sufficiently to ensure the motor plate assembly maintains the desired belt tension.

Note: Since new V-belts tend to stretch after having been placed in operation, check the tension of the belt periodically.

⚠ WARNING

Live Electrical Components!

Failure to follow all electrical safety precautions when exposed to live electrical components could result in death or serious injury. When it is necessary to work with live electrical components, have a qualified licensed electrician or other individual who has been properly trained in handling live electrical components perform these tasks.

8. Being careful not to touch any electrical or moving parts, close the unit disconnect switch and check the unit supply fan for minimum vibration.
9. Open and lock the disconnect switch in the OFF position.
10. Replace all panels.
11. Close the unit disconnect switch.

Table 1. High static drive fan speed (rpm)

Tons	Unit Model Number	6 Turns Open	5 Turns Open	4 Turns Open	3 Turns Open	2 Turns Open	1 Turn Open	Closed
15	E/GCC, E/GDK 180A3,4,W	886	932	979	1026	1072	1119	N/A
17.5	E/GCC, E/GDK 210A3,4,W	978	1030	1081	1133	1184	1236	N/A
20	E/GCC, E/GDK 240A3,4,W	863	918	974	1029	1085	1141	N/A
25	ECC, EDK 300A3,4,W	995	1048	1100	1153	1205	1257	N/A

Note: Factory set at 3 turn open.

Table 2. High static kit - components of converted unit

Unit	Motor Sheave	Fan Sheave	Belt
E/GCC, E/GDK 180A3,4,W	1VP50 x 7/8-inch	BK_80	BX45
E/GCC, E/GDK 210A3,4,W	1VP50 x 7/8-inch	BK140	BX56
E/GCC, E/GDK 240A3,4,W	1VP44 x 7/8-inch	BK130	BX53
ECC, EDK 300A3,4,W	1VP50 x 1-1/8-inch	BK140	BX56

Trane and American Standard create comfortable, energy efficient indoor environments for commercial and residential applications. For more information, please visit trane.com or americanstandardair.com.

Trane and American Standard have a policy of continuous product and product data improvement and reserve the right to change design and specifications without notice. We are committed to using environmentally conscious print practices.