

## Installation Guide

# Hot Gas Bypass Kit

Odyssey™ Split System Cooling Units with  
Symbio™ Controls, 6 to 25 Tons, R-410A/R-454B

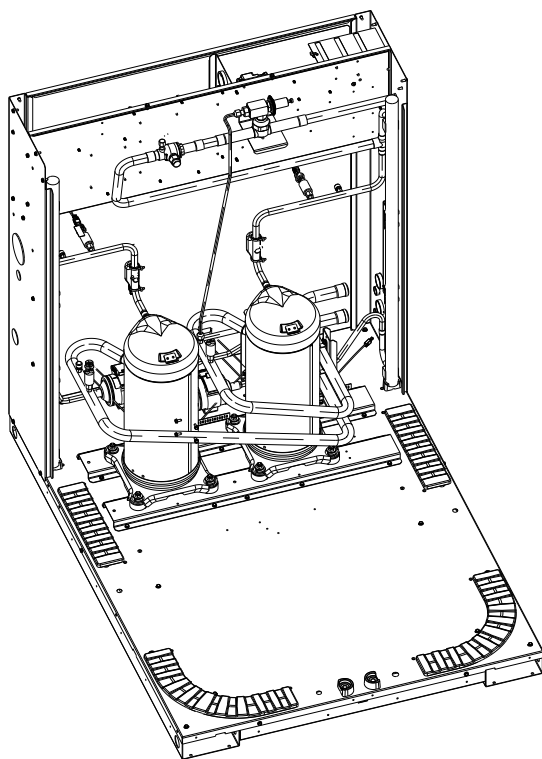

**BAYHGBP010\***: Used with All TTA\*\*\*4\* models

**BAYHGBP011\***: Used with All TTA\*\*\*K\* models

### **▲ SAFETY WARNING**

Only qualified personnel should install and service the equipment. The installation, starting up, and servicing of heating, ventilating, and air-conditioning equipment can be hazardous and requires specific knowledge and training. Improperly installed, adjusted or altered equipment by an unqualified person could result in death or serious injury. When working on the equipment, observe all precautions in the literature and on the tags, stickers, and labels that are attached to the equipment.

# Introduction

Read this manual thoroughly before operating or servicing this unit.

## Warnings, Cautions, and Notices

Safety advisories appear throughout this manual as required. Your personal safety and the proper operation of this machine depend upon the strict observance of these precautions.

The three types of advisories are defined as follows:



Indicates a potentially hazardous situation which, if not avoided, could result in death or serious injury.



Indicates a potentially hazardous situation which, if not avoided, could result in minor or moderate injury. It could also be used to alert against unsafe practices.

**NOTICE**

Indicates a situation that could result in equipment or property-damage only accidents.

## Important Environmental Concerns

Scientific research has shown that certain man-made chemicals can affect the earth's naturally occurring stratospheric ozone layer when released to the atmosphere. In particular, several of the identified chemicals that may affect the ozone layer are refrigerants that contain Chlorine, Fluorine and Carbon (CFCs) and those containing Hydrogen, Chlorine, Fluorine and Carbon (HCFCs). Not all refrigerants containing these compounds have the same potential impact to the environment. Trane advocates the responsible handling of all refrigerants.

## Important Responsible Refrigerant Practices

Trane believes that responsible refrigerant practices are important to the environment, our customers, and the air conditioning industry. All technicians who handle refrigerants must be certified according to local rules. For the USA, the Federal Clean Air Act (Section 608) sets forth the requirements for handling, reclaiming, recovering and recycling of certain refrigerants and the equipment that is used in these service procedures. In addition, some states or municipalities may have additional requirements that must also be adhered to for responsible management of refrigerants. Know the applicable laws and follow them.

### **WARNING**

#### **Proper Field Wiring and Grounding Required!**

Failure to follow code could result in death or serious injury.

**All field wiring MUST be performed by qualified personnel. Improperly installed and grounded field wiring poses FIRE and ELECTROCUTION hazards. To avoid these hazards, you MUST follow requirements for field wiring installation and grounding as described in NEC and your local/state/national electrical codes.**

### **WARNING**

#### **Personal Protective Equipment (PPE) Required!**

Failure to wear proper PPE for the job being undertaken could result in death or serious injury.

Technicians, in order to protect themselves from potential electrical, mechanical, and chemical hazards, **MUST** follow precautions in this manual and on the tags, stickers, and labels, as well as the instructions below:

- **Before installing/servicing this unit, technicians MUST put on all PPE required for the work being undertaken (Examples; cut resistant gloves/sleeves, butyl gloves, safety glasses, hard hat/bump cap, fall protection, electrical PPE and arc flash clothing). ALWAYS refer to appropriate Safety Data Sheets (SDS) and OSHA guidelines for proper PPE.**
- **When working with or around hazardous chemicals, ALWAYS refer to the appropriate SDS and OSHA/GHS (Global Harmonized System of Classification and Labelling of Chemicals) guidelines for information on allowable personal exposure levels, proper respiratory protection and handling instructions.**
- **If there is a risk of energized electrical contact, arc, or flash, technicians MUST put on all PPE in accordance with OSHA, NFPA 70E, or other country-specific requirements for arc flash protection, PRIOR to servicing the unit. NEVER PERFORM ANY SWITCHING, DISCONNECTING, OR VOLTAGE TESTING WITHOUT PROPER ELECTRICAL PPE AND ARC FLASH CLOTHING. ENSURE ELECTRICAL METERS AND EQUIPMENT ARE PROPERLY RATED FOR INTENDED VOLTAGE.**

**⚠ WARNING****Follow EHS Policies!**

Failure to follow instructions below could result in death or serious injury.

- All Trane personnel must follow the company's Environmental, Health and Safety (EHS) policies when performing work such as hot work, electrical, fall protection, lockout/tagout, refrigerant handling, etc. Where local regulations are more stringent than these policies, those regulations supersede these policies.
- Non-Trane personnel should always follow local regulations.

**⚠ WARNING****R-454B Flammable A2L Refrigerant!**

Failure to use proper equipment or components as described below could result in equipment failure, and possibly fire, which could result in death, serious injury, or equipment damage.

The equipment described in this manual uses R-454B refrigerant which is flammable (A2L). Use ONLY R-454B rated service equipment and components. For specific handling concerns with R-454B, contact your local representative.

**⚠ WARNING****Cancer and Reproductive Harm!**

This product can expose you to chemicals including lead and bisphenol A (BPA), which are known to the State of California to cause cancer and birth defects or other reproductive harm. For more information go to [www.P65Warnings.ca.gov](http://www.P65Warnings.ca.gov).

**Copyright**

This document and the information in it are the property of Trane, and may not be used or reproduced in whole or in part without written permission. Trane reserves the right to revise this publication at any time, and to make changes to its content without obligation to notify any person of such revision or change.

**Trademarks**

All trademarks referenced in this document are the trademarks of their respective owners.

**Revision History**

Updated Step 4 in Installation in Air Handler section.

# Table of Contents

Pre-Installation .....	5	Preparation .....	6
General Information.....	5	Installation in Condensing Unit .....	9
Inspection .....	5	Installation of Interconnecting Tubing.....	11
Required Materials.....	5	Installation in Air Handler .....	12
Installation .....	6	Operational Test.....	16
Hot Gas Bypass Kit Installation .....	6		

# Pre-Installation

## General Information

The purpose of a hot gas bypass system is to artificially load the compressor upon a decrease in evaporator load. The Hot Gas Bypass (HGBP) regulator valve automatically responds to changes in suction pressure. When the refrigerant evaporating pressure is above the bypass valve setting, the valve remains closed. When the cooling evaporator load drops, the suction pressure drops below the bypass valve setting and the valve begins to open. A portion of the hot gas is injected directly into the indoor coil distributor, which maintains the compressor suction pressure at the valve set point. The amount of valve opening is proportional to the change in the suction pressure, thereby, providing capacity modulation.

**Important:** The HGBP line should not exceed 75 feet. For greater length, contact applications support.

Low head pressure problems are possible with hot gas bypass applications due to:

- Operation at low outdoor ambient temperatures.
- Some hot gas bypasses the condenser, causing further reduction in head pressure. (The published low ambient limit does not apply when hot gas bypass is utilized.)

The application of a low ambient head pressure control accessory is highly recommended. This accessory kit is designed for R-410A/R-454B applications only and cannot be used on heat pump systems.

## Inspection

1. Unpack all components of the kit.
2. Check carefully for shipping damage. If any damage is found, report it immediately, and file a claim against the transportation company.

## Required Materials

- Copper tube for connection between condensing unit and air handler.
- Tubular insulation suitable for HVAC use - 1/2" minimum thickness.

Figure 1. Materials shipping list

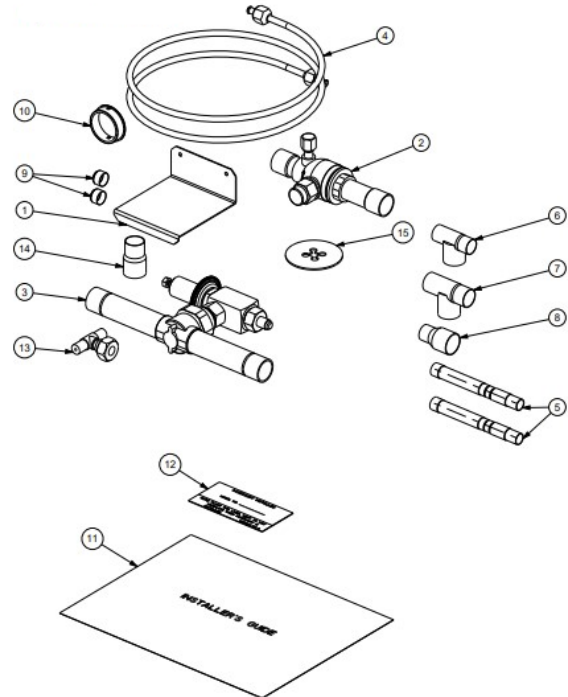

Table 1. Material shipping list

Assembly Number	Qty	Description
1	1	Bracket; Hot Gas Bypass Mounting
2	1	Valve; Ball
3	1	Valve; Hot Gas Bypass
4	1	Tube; Assy-Capillary
5	2	Valve; Check; .50 ID X .50 OD Check
6	1	Tee; Tube; .63 C X .63 C X .88 C
7	1	Tee; Tube; .75 C X .75 C X .88 C
8	1	Reducer; Tube; .88 C X .62 C
9	2	Cap – Copper
10	1	Bushing; Mtg Hole 1.5, 1.31 ID
11	1	Literature; Installation Guide, Hot Gas Bypass
12	1	Label; Installed Accessory
13	1	Tee; Pressure Tap
14	1	Reducer; Tube; .88 C x .75 C
15	1	A2L Red Tab

# Installation

## Hot Gas Bypass Kit Installation

### ⚠ WARNING

#### Hazardous Voltage w/Capacitors!

Failure to disconnect power and discharge capacitors before servicing could result in death or serious injury.

Disconnect all electric power, including remote disconnects and discharge all motor start/run capacitors before servicing. Follow proper lockout/tagout procedures to ensure the power cannot be inadvertently energized. For variable frequency drives or other energy storing components provided by Trane or others, refer to the appropriate manufacturer's literature for allowable waiting periods for discharge of capacitors. Verify with a CAT III or IV voltmeter rated per NFPA 70E that all capacitors have discharged.

### ⚠ WARNING

#### Refrigerant Vapor Hazard!

Refrigerant vapors may collect and concentrate in confined spaces or low lying areas which will result in the displacement of air. This poses a potential health risk due to suffocation. Failure to follow proper handling guidelines could result in death or serious injury.

Refer to the appropriate MSDS or SDS sheets and OSHA/GHS guidelines for information referring to allowable personal exposure levels and handling guidelines.

## Preparation

*Note: Some aspects of the installation, such as top cover removal, may require an additional technician.*

1. Ensure all power to the unit has been disconnected and locked out.
2. Remove compressor access panel and top cover on the B-side of the unit (TTA 13-25 ton, see [Figure 2, p. 6](#)), leaving the condenser motor and fan assembly intact.

*Note: This is accomplished by removing the screws in the edge of the top cover. Lift the edge of the cover, opposite the control box, and lay it across the control box section. It is not necessary to disconnect the motor leads (See [Figure 2, p. 6](#)).*

Figure 2. Access panel and top cover removal

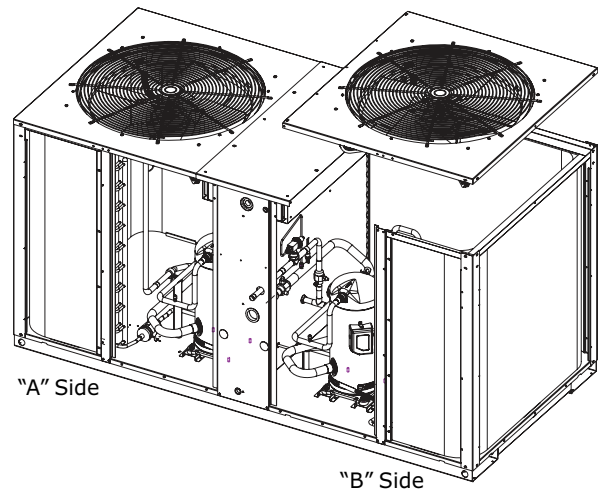
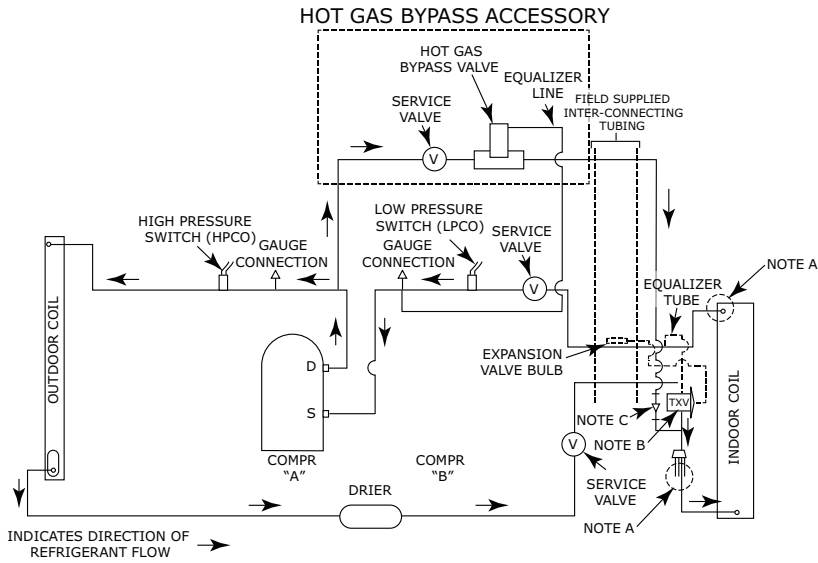

Figure 3. Typical HGBP schematic — single/dual compressor



NOTE A: ONLY ONE OUTDOOR AND INDOOR COIL REFRIGERANT ENTRY AND EXIT CIRCUIT IS SHOWN. ALL MODELS HAVE MULTIPLE ENTRY AND EXIT CIRCUITS.

NOTE B: ONLY ONE TXV IS SHOWN. THIS IS NOT REPRESENTATIVE OF ALL SYSTEMS.

NOTE C: CHECK VALVE INSTALLED REVERSE OF FACTORY ORIENTATION. SEE DETAILS IN AIR HANDLER INSTALLATION SECTION.

NOTE D: SERVICE VALVES NOT INCLUDED WITH HOT GAS BYPASS ACCESSORY ARE SEPARATE FIELD INSTALLED ACCESSORIES.

Figure 4. Typical HGBP schematic — manifolded compressor

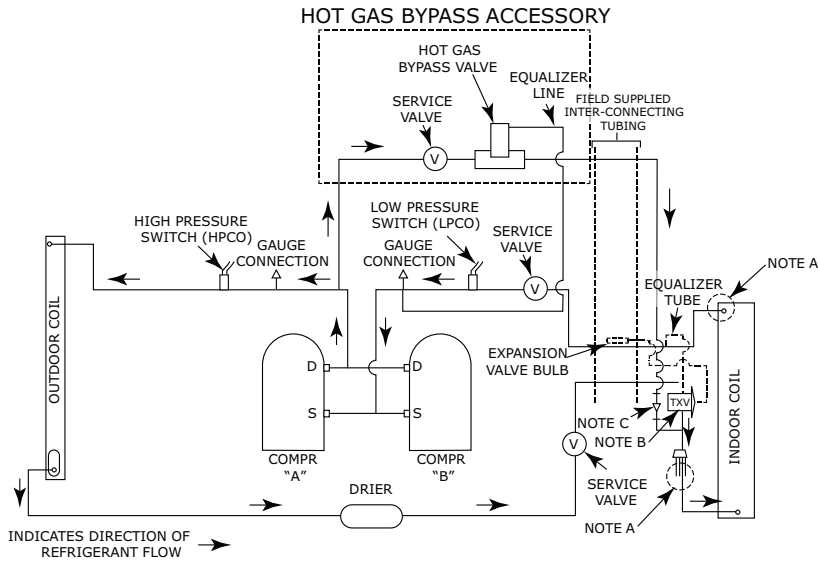

NOTE A: ONLY ONE OUTDOOR AND INDOOR COIL REFRIGERANT ENTRY AND EXIT CIRCUIT IS SHOWN. ALL MODELS HAVE MULTIPLE ENTRY AND EXIT CIRCUITS.

NOTE B: ONLY ONE TXV IS SHOWN. THIS IS NOT REPRESENTATIVE OF ALL SYSTEMS.

NOTE C: CHECK VALVE INSTALLED REVERSE OF FACTORY ORIENTATION. SEE DETAILS IN AIR HANDLER INSTALLATION SECTION.

NOTE D: SERVICE VALVES NOT INCLUDED WITH HOT GAS BYPASS ACCESSORY ARE SEPARATE FIELD INSTALLED ACCESSORIES.

## ⚠ WARNING

### Refrigerant under High Pressure!

Failure to follow instructions below could result in an explosion which could result in death or serious injury or equipment damage.

System contains refrigerant under high pressure. Recover refrigerant to relieve pressure before opening the system. See unit nameplate for refrigerant type. Do not use non-approved refrigerants, refrigerant substitutes, or refrigerant additives.

## ⚠ WARNING

### R-410A Refrigerant under Higher Pressure than R-22!

Failure to use proper equipment or components as described below, could result in equipment failing and possibly exploding, which could result in death, serious injury, or equipment damage.

The units described in this manual use R-410A refrigerant which operates at higher pressures than R-22. Use ONLY R-410A rated service equipment or components with these units. For specific handling concerns with R-410A, please contact your local Trane representative.

## ⚠ WARNING

### R-454B Flammable A2L Refrigerant!

Failure to use proper equipment or components as described below could result in equipment failure, and possibly fire, which could result in death, serious injury, or equipment damage.

The equipment described in this manual uses R-454B refrigerant which is flammable (A2L). Use ONLY R-454B rated service equipment and components. For specific handling concerns with R-454B, contact your local representative.

## ⚠ WARNING

### Risk of Fire — Flammable Refrigerant!

Failure to follow instructions below could result in death or serious injury, and equipment damage.

- To be repaired only by trained service personnel.
- Do not puncture refrigerant tubing.
- Dispose of properly in accordance with federal or local regulations.

**Important:** Refrigerant must not be vented to the atmosphere.

3. For new installations, release the nitrogen holding charge by removing line connection caps and slowly

opening the field-installed service valve. For existing installations, properly recover refrigerant from the system. If R-454B refrigerant is used, refer to the unit Installation, Operation, and Maintenance (IOM) guide, and follow the requirements listed in the A2L Work Procedures section.

4. The installed accessory requires an additional refrigerant line installed between the condensing unit and the air handler. See [Table 3, p. 10](#) for the requirements of this line.
5. Check the HGBP diagrams, to determine the exact location for cutting the tubing and placing the tees in the refrigerant lines.
6. Drill/punch hole in sheet metal panel in both the condensing unit and air handler to allow passage of the hot gas bypass tube, see [Figure 5, p. 8](#). Insert the provided bushings in the holes.
7. Cleaning, Cutting, and Fitting: Clean the outside surface of tube with sandpaper or steel wool at the location you plan to cut and install the "T" coupling. When cutting the tubing always use a tube cutter. After the tubing has been cut, its ends must be scraped or reamed with a pointed tool to remove any sharp burr in the end of the tube. Using a clean dry cloth, wipe away any small metal particles that may be in or around newly cut edges.

**Figure 5. Hole placement for HGBP tube**

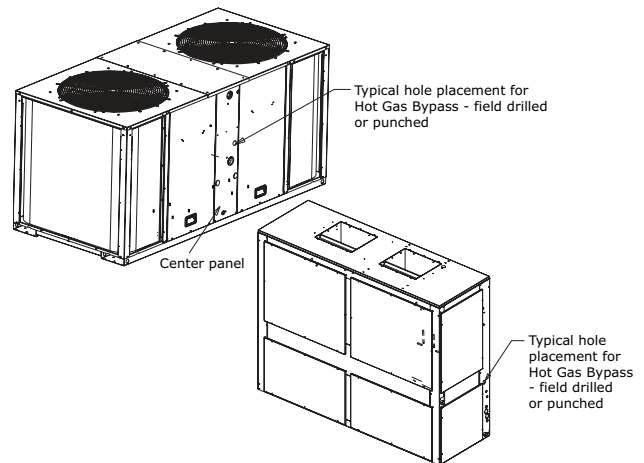

## Installation in Condensing Unit

**Figure 6. Outdoor units - refrigerant piping (with dry nitrogen) Dry nitrogen supply hook-up**

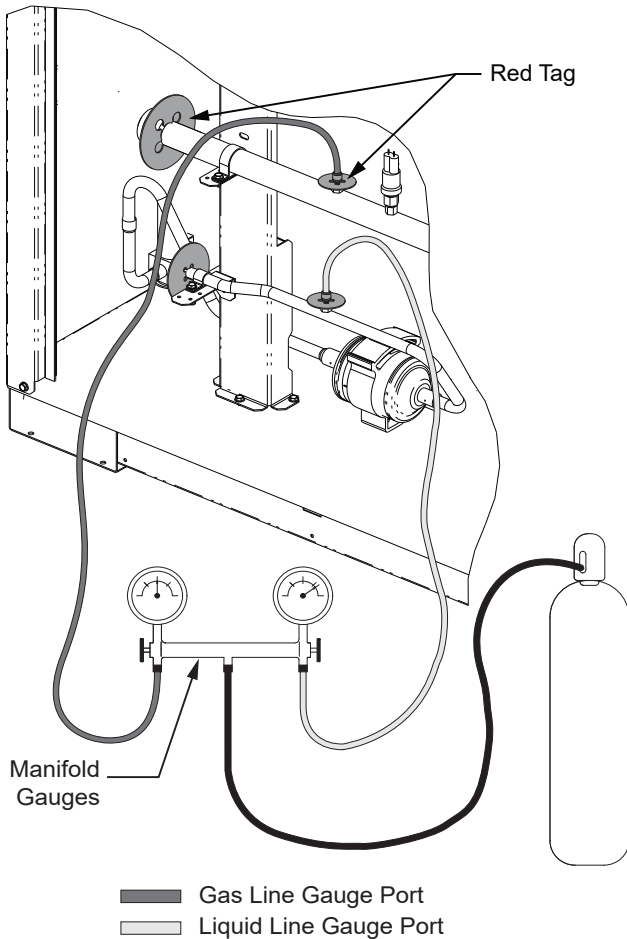

1. Using a tube cutter, remove a 1/2" to 3/4" length of tube from the common compressor discharge (hot gas) line (reference preparation [Step 5](#) and [Figure 9, p. 13](#)).
2. Remove plugs from the tubing ends of the HGBP accessory.
3. From the interior of the condensing unit, assemble outlet end of the HGBP accessory with bracket punched hole through the bushing in the center panel. Insert the cut ends of the common discharge line into the inlet "T" of the accessory. Continue to refer [Figure 9, p. 13](#) while positioning the tubing assembly.

### NOTICE

#### Equipment Damage!

When installing bracket, be careful not to damage any parts in the control box.

4. With the installation of the HGBP accessory complete, ensure that it does not come in contact with any metal that may rub or "chatter" during operation.
5. Ensure manifold gauge hoses are attached to the

service ports (one discharge port and one suction port) on the system.

6. Attach center line manifold gauge to a dry nitrogen supply.

### ⚠ WARNING

#### Explosion Hazard!

Failure to follow these instructions could result in death or serious injury or equipment or property-only damage.

Use only dry nitrogen with a pressure regulator for pressurizing unit. Do not use acetylene, oxygen or compressed air or mixtures containing them for pressure testing. Do not use hydrogen mixtures containing refrigerant and air above atmospheric pressure for pressure testing as they may become flammable and could result in an explosion. Refrigerant, when used as a trace gas should only be mixed with dry nitrogen for pressurizing units.

7. Flow dry nitrogen through the system at about 2 to 3 psig (avoid any positive pressure buildup).

### NOTICE

#### Equipment Damage!

Painted areas of the unit must be shielded during brazing and all valves wrapped with a wet cloth to protect from heat.

### ⚠ WARNING

#### Explosion Hazard and Deadly Gases!

Failure to follow all proper safe refrigerant handling practices could result in death or serious injury. Never solder, braze or weld on refrigerant lines or any unit components that are above atmospheric pressure or where refrigerant may be present. Always remove refrigerant by following the guidelines established by the EPA Federal Clean Air Act or other state or local codes as appropriate. After refrigerant removal, use dry nitrogen to bring system back to atmospheric pressure before opening system for repairs. Mixtures of refrigerants and air under pressure may become combustible in the presence of an ignition source leading to an explosion. Excessive heat from soldering, brazing or welding with refrigerant vapors present can form highly toxic gases and extremely corrosive acids.

8. Begin brazing at the "T" on the common compressor discharge gas line. Braze the copper joints leak tight.
9. After brazing, shut off and disconnect nitrogen supply.
10. Remove the schraeder core and reg tag (only applicable for R-454B units) on the suction line service port shown on [Figure 9, p. 13](#) or [Figure 10, p. 14](#). Attach the tee with a flare nut to the access port and HGBP equalizer line onto the service port that does not

## Installation

have a schraeder core inside. For R-454B units, install the red tag in the new service port location before installing the cap.

11. For R-454B units, install the Baykit red tags on the newly added service valve port (installed on the discharge line).
12. Re-install the top cover.
13. Evacuate the condensing unit.

**Table 2. Discharge line sizes**

Unit	Discharge Line	
	5/8"	3/4"
060, 072	X	
076**A, 090**A		X
076**D, 090**D	X	
101**A, 120**A		X
101**D, 120**D	X	
101**C, 120**C		X
126, 150	X	
156**D, 180**D	X	
156**C, 180**C		X
201**D, 240**D		X
201**C, 240**C		X
251, 300		X

**Table 3. HGBP line sizes**

Unit	HGBP Line	
	5/8"	3/4"
060, 072	X	
076, 090	X	

**Table 3. HGBP line sizes (continued)**

Unit	HGBP Line	
	5/8"	3/4"
101**A, 120**A		X
101**D, 120**D	X	
101**C, 120**C	X	
126, 150	X	
156**D, 180**D	X	
156**C, 180**C	X	
201**D, 240**D		X
201**C, 240**C		X
251, 300		X

**Notes:**

- The oil-return line is field supplied and installed.
- The drip leg is attached to the suction line using 5 feet of 1/8" tubing. This allows for proper oil return to the compressor and avoids equipment damage.
- Refer to Equipment Damage notice in the "Installation of Interconnecting Tubing," p. 11 for additional details.
- No oil return leg is needed when the condenser is mounted above the air handler.
- The oil return leg can be connected anywhere in the suction line.
- No traps are necessary when lines are sized properly. See application guide (SS-APG008\*-EN or SS-APG009\*-EN for R-410A units and SS-APG017\*-EN or SS-APG018\*-EN for R-454B units).

Figure 7. Hot gas bypassed to evaporator inlet

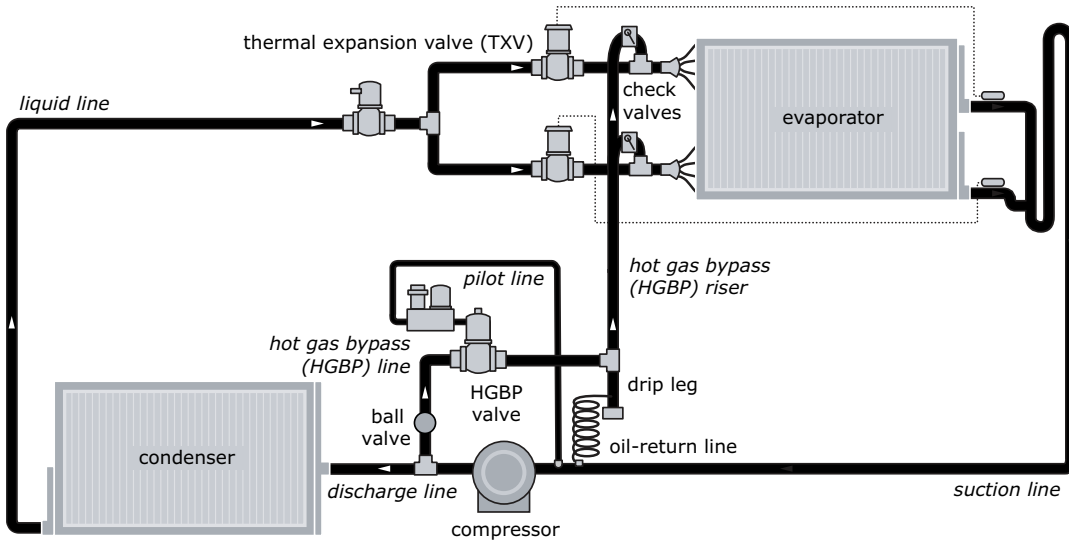

## Installation of Interconnecting Tubing

### ⚠ WARNING

#### Explosion Hazard and Deadly Gases!

Failure to follow all proper safe refrigerant handling practices could result in death or serious injury. Never solder, braze or weld on refrigerant lines or any unit components that are above atmospheric pressure or where refrigerant may be present. Always remove refrigerant by following the guidelines established by the EPA Federal Clean Air Act or other state or local codes as appropriate. After refrigerant removal, use dry nitrogen to bring system back to atmospheric pressure before opening system for repairs. Mixtures of refrigerants and air under pressure may become combustible in the presence of an ignition source leading to an explosion. Excessive heat from soldering, brazing or welding with refrigerant vapors present can form highly toxic gases and extremely corrosive acids.

### ⚠ WARNING

#### Explosion Hazard!

Failure to follow these instructions could result in death or serious injury or equipment or property-only damage. Use only dry nitrogen with a pressure regulator for pressurizing unit. Do not use acetylene, oxygen or compressed air or mixtures containing them for pressure testing. Do not use hydrogen mixtures containing refrigerant and air above atmospheric pressure for pressure testing as they may become flammable and could result in an explosion. Refrigerant, when used as a trace gas should only be mixed with dry nitrogen for pressurizing units.

**Note:** For existing installations, skip steps 1 and 2.

1. Keep any installed service valves shut. Flow dry nitrogen through the HGBP line at about 2 to 3 psig (avoid any positive pressure buildup). See [Figure 3, p. 7](#) and [Figure 4, p. 7](#).
2. Braze in the suction and liquid interconnecting tubing per unit Installation, Operation, and Maintenance (IOM) Guide.
3. Install a hot gas bypass line from the end of the HGBP accessory into the air handler section through the punched hole. Extend tube into air handler clear of any obstructions for future brazing. See [Figure 2, p. 6](#).

### NOTICE

#### Equipment Damage!

Failure to prevent trapping oil in the HGBP line could result in equipment damage. Horizontal sections of HGBP lines should always slope in a direction which allows gravity to naturally drain any oil toward a point of return to the system. If the HGBP line has a vertical riser, a drip leg is required. The drip leg is attached to the suction line using 5 feet of 1/8" tubing. The HGBP line should not exceed 75-feet in total length. Contact a technical service representative if any specific questions arise during installation.

4. Braze the HGBP line into the system, starting from the condensing unit and working toward the air handler.

**Important:** Horizontal sections of HGBP lines should always slope in a direction which allows gravity to naturally drain any oil or liquid refrigerant away from the HGBP valve.

## Installation in Air Handler

### ⚠ WARNING

#### Explosion Hazard!

Failure to follow these instructions could result in death or serious injury or equipment or property-only damage.

Use only dry nitrogen with a pressure regulator for pressurizing unit. Do not use acetylene, oxygen or compressed air or mixtures containing them for pressure testing. Do not use hydrogen mixtures containing refrigerant and air above atmospheric pressure for pressure testing as they may become flammable and could result in an explosion.

Refrigerant, when used as a trace gas should only be mixed with dry nitrogen for pressurizing units.

### ⚠ WARNING

#### Explosion Hazard and Deadly Gases!

Failure to follow all proper safe refrigerant handling practices could result in death or serious injury. Never solder, braze or weld on refrigerant lines or any unit components that are above atmospheric pressure or where refrigerant may be present. Always remove refrigerant by following the guidelines established by the EPA Federal Clean Air Act or other state or local codes as appropriate. After refrigerant removal, use dry nitrogen to bring system back to atmospheric pressure before opening system for repairs. Mixtures of refrigerants and air under pressure may become combustible in the presence of an ignition source leading to an explosion. Excessive heat from soldering, brazing or welding with refrigerant vapors present can form highly toxic gases and extremely corrosive acids.

1. Ensure any service valves are closed on the condensing unit. Attach manifold gauge hoses to the ports of the service valves (suction and liquid).
2. Attach center line manifold gauge to a dry nitrogen supply.
3. Flow dry nitrogen through the HGBP line at about 2 to 3 psig (avoid any positive pressure buildup).
4. Using a brazing torch, unsweat the factory installed check valves (Circuit A only for dual circuit units) which are on the distributor side ports, as shown in [Figure 8](#), p. 12.

Figure 8. Location of check valve

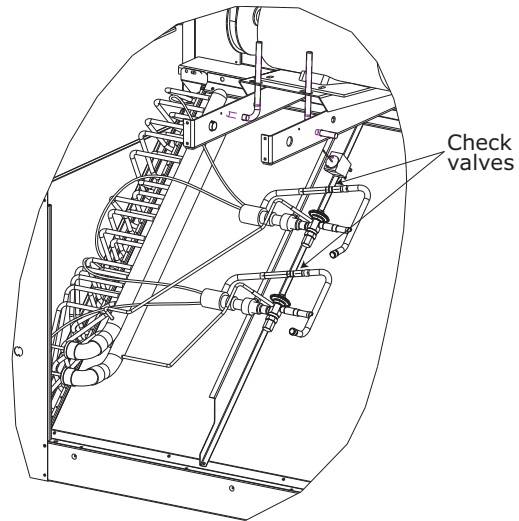

**Note:** If removing the valve is difficult, a tubing cutter can be used to first cut the factory check valve in half and then sweat out either end. New check valves are supplied with this kit.

5. Shut off nitrogen supply.
6. Fit up all of the interconnecting tubing before brazing on the system. See [Figure 11](#), p. 15 and [Figure 12](#), p. 16 for details. Using the parts provided, cap the liquid lines for all units except TWE251/300 and lay out the tubing as shown in the diagrams. This layout ensures proper oil return to the compressor.
7. Install oil return line between drip leg and compressor suction tubing. See [Figure 7](#), p. 11.
8. Connect nitrogen supply to HGBP and liquid line service ports. Flow dry nitrogen through the system at about 2 to 3 psig (avoid any positive pressure buildup).
9. Braze together evaporator coil tubing starting with the HGBP line. Work from the point it enters the air handler toward the distributor. Braze on the liquid line caps where applicable. Braze the copper joints leak tight.
10. After brazing, shut off and disconnect nitrogen supply.
11. Open all installed service valves.

### ⚠ WARNING

#### Explosion Hazard!

Failure to follow safe leak test procedures below could result in death or serious injury or equipment or property-only-damage.

Never use an open flame to detect gas leaks. Use a leak test solution for leak testing.

12. Insulate the HGBP line with tubing insulation from the outdoor unit to the indoor unit. Extend the insulation into the air handler up to the installed "T" fitting. Ensure the insulation is properly secured to the tube. Seal any cabinet air gaps around the HGBP line entry point.

13. Evacuate, leak check, and charge the system; referring to the unit IOM for the proper procedures.

**Figure 9. Condensing unit - typical HGBP accessory layout (single circuit system shown, dual circuit systems will only go to circuit A)**

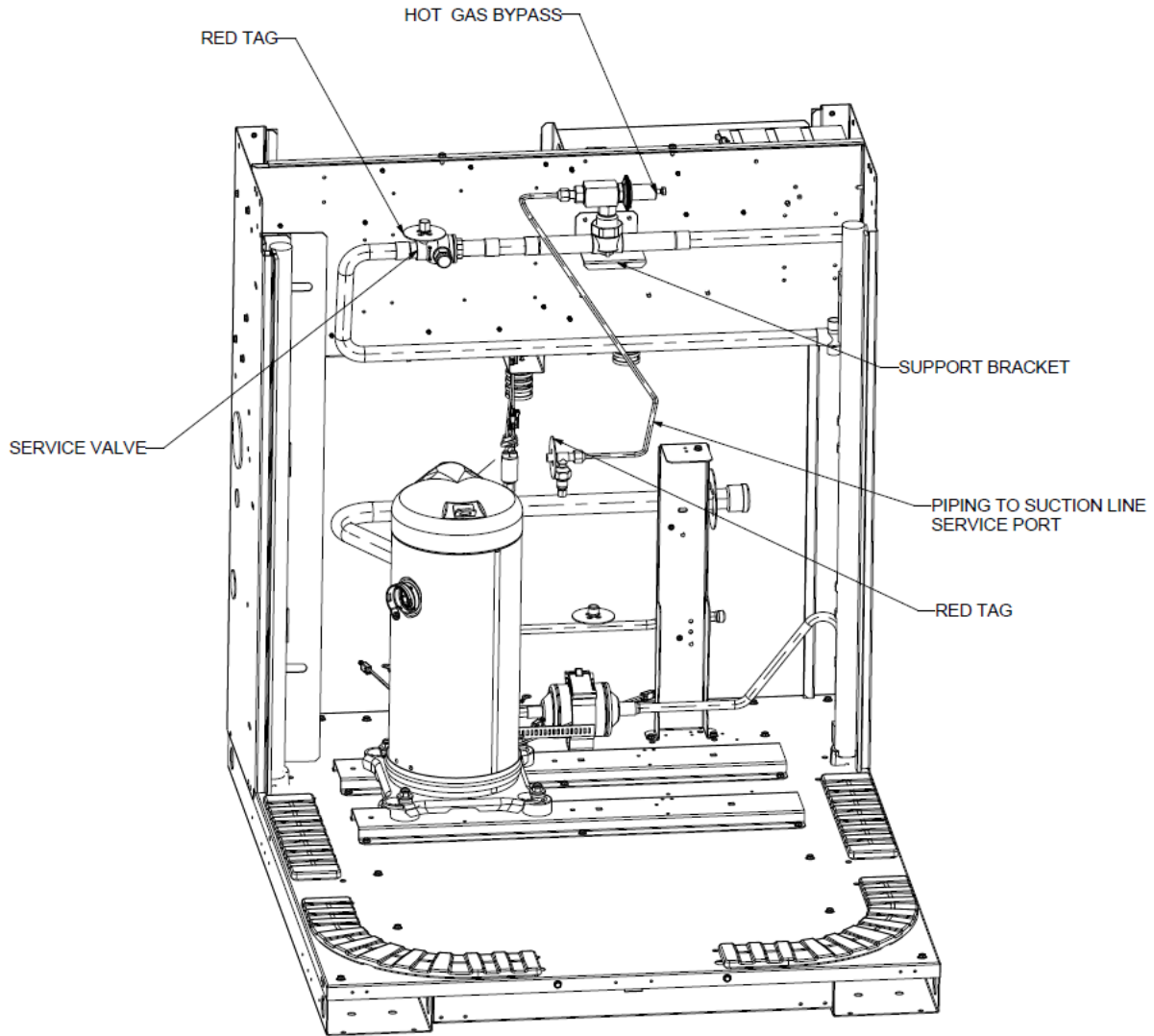

Installation

Figure 10. Condensing unit - typical HGBP accessory layout (manifolded system shown, dual circuit systems will only go to circuit A)

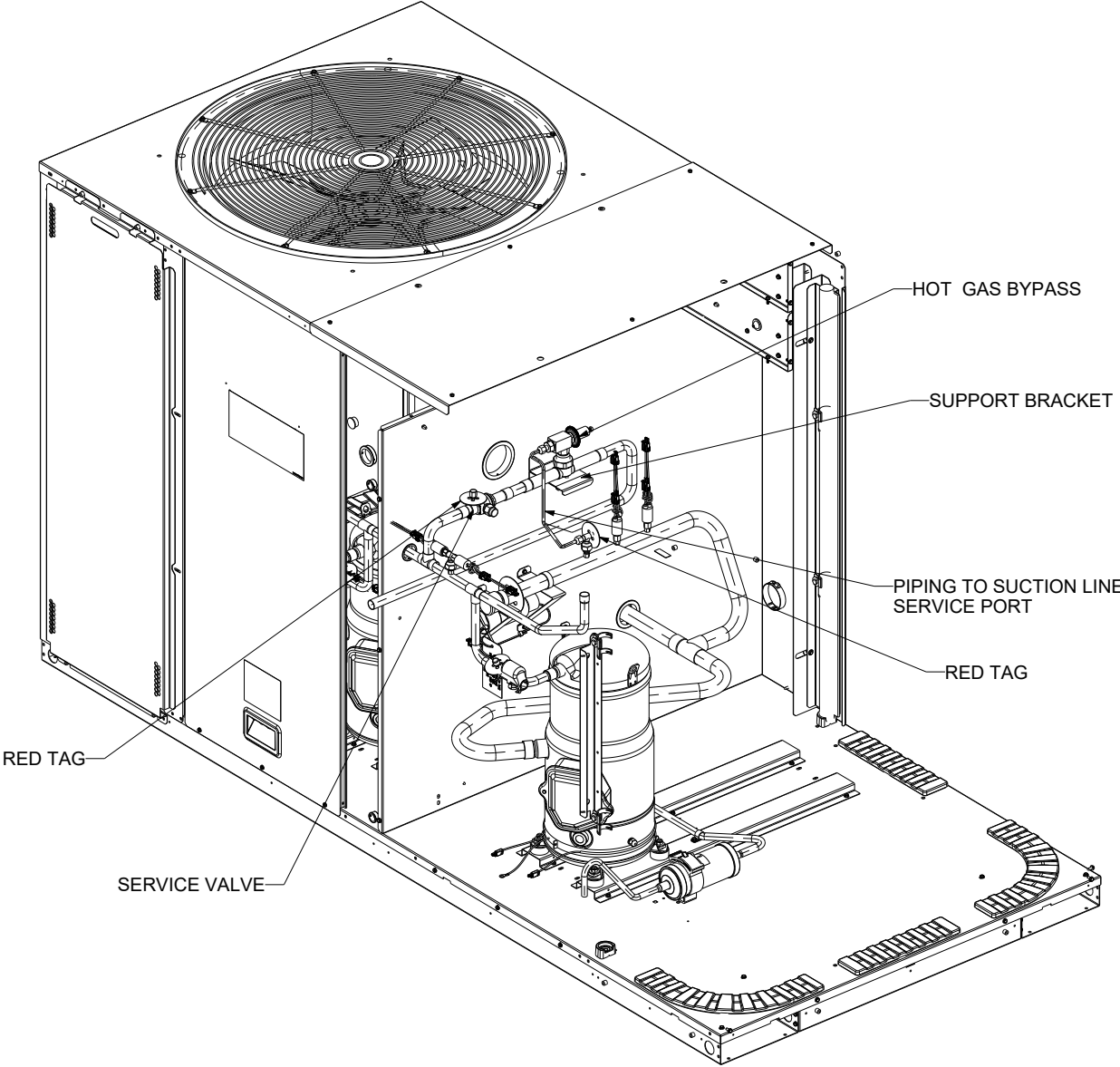

Figure 11. Air handler HGBP accessory layout (manifolded system shown. dual circuit systems will only go to circuit A)

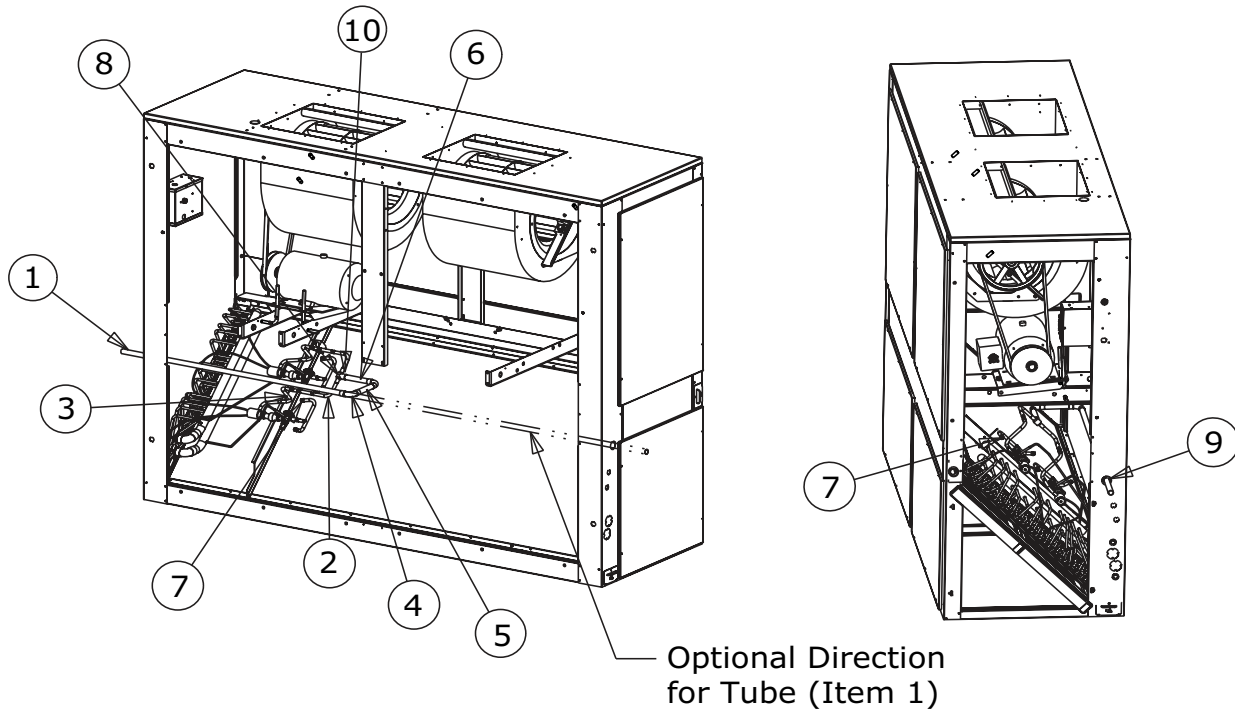

Table 4. Air handler HGBP accessory layout

Item Number	Description	Quantity Required	Provided with Kit?	
			Yes	No
1	Tubing	1		X
2	Tube	2		X
3	Check Valve ASM	2	X	
4	Elbow	2		X
5	Tube	1		X
6	Tube	1		X
7	1/2 Tube Cap	2	X	
8	5/8 x 5/8 x 5/8 Tee	1		X
9	Bushing	1	X	
10	Reducer 5/8 x 7/8	1	X	

Notes:

1. All parts not needed for every application.
2. Two check valves only needed for manifolded systems.
3. Items reference Figure 11, p. 15.

**Figure 12. Tubing layout (manifold system shown; dual circuit systems will only go to circuit A)**

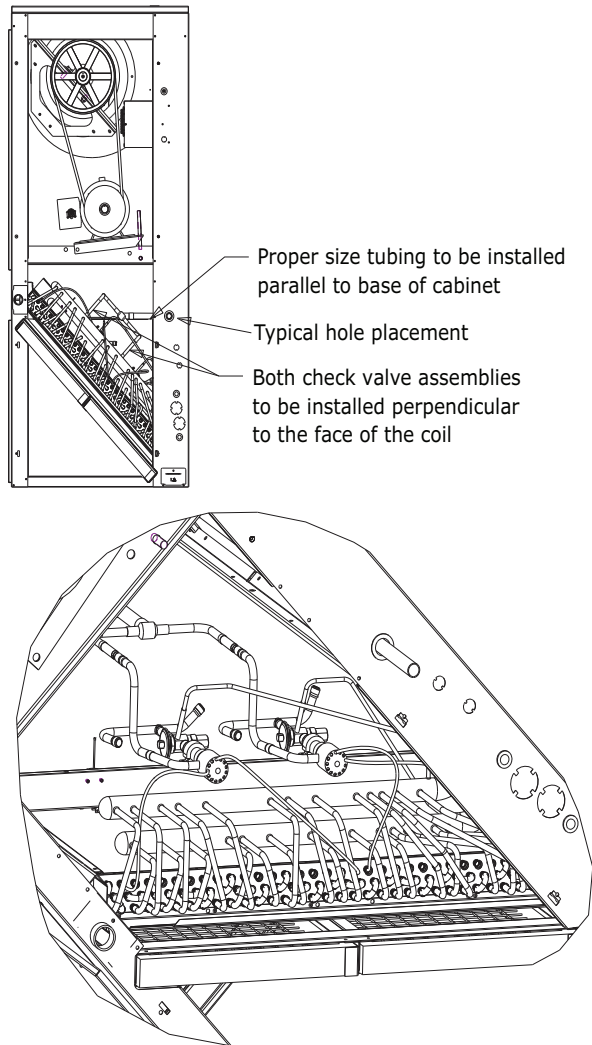

## Operational Test

1. Close HGBP service valve.
2. Start the system and check for proper operation per unit IOM.
3. Slowly open the HGBP service valve.
4. The HGBP valve will begin to cycle and bypass at suction pressures lower than the factory set point of 102 psig for R-410A or 92 psig for R-454B. Above this pressure the system will operate normally without the use of HGBP.

Operation of the HGBP system can be verified by briefly shutting off the indoor fan while monitoring refrigerant pressures at the condensing unit. Once the indoor airflow blower has stopped, the HGBP valve will begin to open when the suction pressure drops below 102 psig for R-410A or 92 psig for R-454B. The opening of the valve will be accompanied by an audible hiss of refrigerant flowing through the hot gas line. If the valve has opened at the specified pressure level, the system is operational. Restart the indoor air handler. The HGBP service valve must remain open.

The factory set point ensures reliable operation for a typical split system layout. If adjustment of the suction pressure set point is found to be necessary, the HGBP valve is setscrew adjustable between 75 and 150 psig (CW increases the setpoint and CCW decreases). This procedure should only be conducted by qualified technicians.







Trane and American Standard create comfortable, energy efficient indoor environments for commercial and residential applications. For more information, please visit [trane.com](http://trane.com) or [americanstandardair.com](http://americanstandardair.com).

Trane and American Standard have a policy of continuous product and product data improvement and reserve the right to change design and specifications without notice. We are committed to using environmentally conscious print practices.

ACC-SVN116J-EN 14 Mar 2026  
Supersedes ACC-SVN116H-EN (August 2024)

©2026