

Installation Instructions

Precedent™ Packaged Rooftop Units

Power Exhaust Kit - Standard and Low Leak Economizers

3 to 5 Tons

Note: See "Wiring Installation" on page 8 for Economizer Actuator Note.

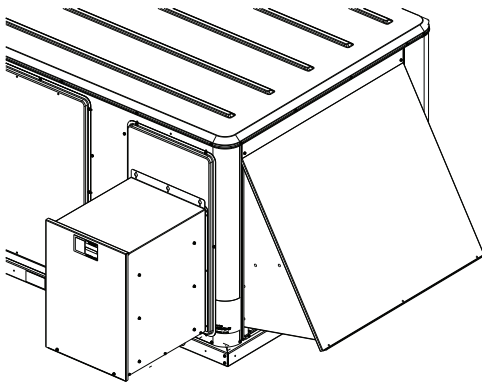

STANDARD ECONOMIZER

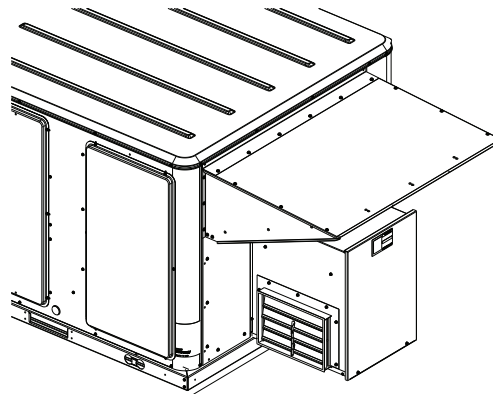

LOW LEAK ECONOMIZER

Model Number:	Used With:
BAYPWRX070*	T/YHC036 - 067E3, T/YHC048-060F3, T/YZC036-060*3, T/YSC036-060G3, D/W*C036-060H3
BAYPWRX071*	T/YHC036 - 067E4, T/YHC048-060F4, T/YZC036-060*4, T/YSC036-060G4, D/W*C036-060H4
BAYPWRX072*	T/YHC036 - 060EW, T/YHC048-060FW, T/YSC036-060GW, D/W*C036-060HW

⚠ SAFETY WARNING

Only qualified personnel should install and service the equipment. The installation, starting up, and servicing of heating, ventilating, and air-conditioning equipment can be hazardous and requires specific knowledge and training. Improperly installed, adjusted or altered equipment by an unqualified person could result in death or serious injury. When working on the equipment, observe all precautions in the literature and on the tags, stickers, and labels that are attached to the equipment.

Introduction

Read this manual thoroughly before operating or servicing this unit.

Warnings, Cautions, and Notices

Safety advisories appear throughout this manual as required. Your personal safety and the proper operation of this machine depend upon the strict observance of these precautions.

The three types of advisories are defined as follows:

⚠ WARNING Indicates a potentially hazardous situation which, if not avoided, could result in death or serious injury.

⚠ CAUTION Indicates a potentially hazardous situation which, if not avoided, could result in minor or moderate injury. It could also be used to alert against unsafe practices.

NOTICE Indicates a situation that could result in equipment or property-damage only accidents.

Important Environmental Concerns

Scientific research has shown that certain man-made chemicals can affect the earth's naturally occurring stratospheric ozone layer when released to the atmosphere. In particular, several of the identified chemicals that may affect the ozone layer are refrigerants that contain Chlorine, Fluorine and Carbon (CFCs) and those containing Hydrogen, Chlorine, Fluorine and Carbon (HCFCs). Not all refrigerants containing these compounds have the same potential impact to the environment. Trane advocates the responsible handling of all refrigerants-including industry replacements for CFCs and HCFCs such as saturated or unsaturated HFCs and HCFCs.

Important Responsible Refrigerant Practices

Trane believes that responsible refrigerant practices are important to the environment, our customers, and the air conditioning industry. All technicians who handle refrigerants must be certified according to local rules. For the USA, the Federal Clean Air Act (Section 608) sets forth the requirements for handling, reclaiming, recovering and recycling of certain refrigerants and the equipment that is used in these service procedures. In addition, some states or municipalities may have additional requirements that must also be adhered to for responsible management of refrigerants. Know the applicable laws and follow them.

⚠ WARNING

Proper Field Wiring and Grounding Required!

Failure to follow code could result in death or serious injury. All field wiring **MUST** be performed by qualified personnel. Improperly installed and grounded field wiring poses **FIRE** and **ELECTROCUTION** hazards. To avoid these hazards, you **MUST** follow requirements for field wiring installation and grounding as described in NEC and your local/state/national electrical codes.

⚠ WARNING

Personal Protective Equipment (PPE) Required!

Failure to wear proper PPE for the job being undertaken could result in death or serious injury. Technicians, in order to protect themselves from potential electrical, mechanical, and chemical hazards, **MUST** follow precautions in this manual and on the tags, stickers, and labels, as well as the instructions below:

- Before installing/servicing this unit, technicians **MUST** put on all PPE required for the work being undertaken (Examples; cut resistant gloves/sleeves, butyl gloves, safety glasses, hard hat/bump cap, fall protection, electrical PPE and arc flash clothing). **ALWAYS** refer to appropriate Safety Data Sheets (SDS) and OSHA guidelines for proper PPE.
- When working with or around hazardous chemicals, **ALWAYS** refer to the appropriate SDS and OSHA/GHS (Global Harmonized System of Classification and Labeling of Chemicals) guidelines for information on allowable personal exposure levels, proper respiratory protection and handling instructions.
- If there is a risk of energized electrical contact, arc, or flash, technicians **MUST** put on all PPE in accordance with OSHA, NFPA 70E, or other country-specific requirements for arc flash protection, **PRIOR** to servicing the unit. **NEVER PERFORM ANY SWITCHING, DISCONNECTING, OR VOLTAGE TESTING WITHOUT PROPER ELECTRICAL PPE AND ARC FLASH CLOTHING. ENSURE ELECTRICAL METERS AND EQUIPMENT ARE PROPERLY RATED FOR INTENDED VOLTAGE.**

⚠ WARNING

Follow EHS Policies!

Failure to follow instructions below could result in death or serious injury.

- All Trane personnel must follow the company's Environmental, Health and Safety (EHS) policies when performing work such as hot work, electrical, fall protection, lockout/tagout, refrigerant handling, etc. Where local regulations are more stringent than these policies, those regulations supersede these policies.
- Non-Trane personnel should always follow local regulations.

Important: *Installation of this power exhaust kit will affect unit level MCA/MOP having a direct impact on existing field wiring and unit protection devices. The change in MCA/MOP is the sole responsibility of the installing party and any modifications to wiring and/or fusing may violate the UL certification and local codes. Trane will not issue new nameplates as a result of this power exhaust accessory installation.*

Copyright

This document and the information in it are the property of Trane, and may not be used or reproduced in whole or in part without written permission. Trane reserves the right to revise this publication at any time, and to make changes to its content without obligation to notify any person of such revision or change.

Trademarks

All trademarks referenced in this document are the trademarks of their respective owners.

Revision History

Updated Power Wiring section in Wiring Installation chapter.

Table of Contents

General Information	5
Model Number Description	5
General	5
Inspection	5
Prepare for Installation	5
Standard Economizer Installation	5
Recommended procedure	5
Low Leak Economizer Installation	7
Wiring Installation	8
ReliaTel™ Controls Wiring	8
Electromechanical Controls Wiring	9
Switch Kit Installation	9
Electromechanical Controls	9
Power Wiring	10
Electromechanical Unit Power Exhaust Operation and Settings	10
ReliaTel™ Unit Power Exhaust Operation and Settings	10
Units without a ReliaTel™ Options Module (RTOM)	10
ReliaTel™ Units with an RTOM and without Ventilation Override Accessory	10
ReliaTel™ Units with an RTOM and with an Optional Ventilation Override Accessory ..	10
Close Out Installation	11

General Information

Model Number Description

All products are identified by a multiple-character model number that precisely identifies a particular type of unit. Its use will enable the owner/operator, installing contractors, and service engineers to define the operation, specific components, and other options for any specific unit. When ordering replacement parts or requesting service, be sure to refer to the specific model number and serial number printed on the unit nameplate.

General

Power exhaust was designed for downflow applications¹. If the installation is for horizontal duct connections, the Power Exhaust may possibly be mounted on the horizontal return duct. However, the installer must be responsible for determining how to make the installation complete.

An economizer or motorized damper must be installed and functional before attempting to install the power exhaust. The power exhaust can be turned "ON" at infinite fresh air damper settings depending on how the unit is configured. Depending on whether it is ReliaTel™, with or without the RTOM, or electromechanical configuration will determine what flexibility you have.

Table 1. Parts list

Qty	Description	Qty	Description
1	Power Exhaust Assembly	1	Edge Protector
1	AB Power Exhaust Hood (3 pieces)	1	Label
1	CD Power Exhaust Hood (3 pieces)	5	Quick Splice; 18 ga. (Red)
1	AB Duct Cover Template Drawing	3	Quick Splice; 14 ga. (Blue)
1	Gasket	7	Wire Tie; Pop-In
1	Sealant; Silicone Rubber	2	Wire Tie
14	Screw; 10-16 X 0.50	1	Replacement Angle Bracket for Damper Motor (used on electromechanical units only)
12	Screw; 10-16 X.56 (Self Tapping)	1	Econ Logic Mounting Screw, #6-19 x 0.625
1	Bushing	1	CD Duct Cover Template Drawing

Inspection

1. Unpack all components of the power exhaust kit.
2. Remove hardware package from power exhaust assembly.
3. Check carefully for any shipping damage. If any damage is found it must be reported immediately and a claim made against the transportation company.

¹ Downflow application only is possible for units with Low Leak Economizers.

⚠ WARNING

Hazardous Voltage w/Capacitors!

Failure to disconnect power and discharge capacitors before servicing could result in death or serious injury. Disconnect all electric power, including remote disconnects and discharge all motor start/run capacitors before servicing. Follow proper lockout/tagout procedures to ensure the power cannot be inadvertently energized. For variable frequency drives or other energy storing components provided by Trane or others, refer to the appropriate manufacturer's literature for allowable waiting periods for discharge of capacitors. Verify with a CAT III or IV voltmeter rated per NFPA 70E that all capacitors have discharged.

Prepare for Installation

1. Open and lock unit disconnect before attempting to install this accessory.
2. Remove the filter access panel from front side of the unit.
3. Remove the compressor access panel from front side of the unit.
4. Remove the return air panel from back side of the unit.

Standard Economizer Installation

Use the template for the return air panel provided in the hardware kit to locate positions to drill holes and cut required new opening.

Note: Use template that corresponds to unit / return panel size. Do not cut a hole for units that have a Low Leak Economizer installed.

Recommended procedure

Place the template into position for drilling and cutting, and secure it with pieces of duct tape (field supplied).

Important: Alignment of the template is critical. Instructions for alignment and cutting are printed on the template.

1. Drill three 1/8 inch holes in the template and panel for engagement holes. Refer to template.

General Information

Figure 1. Power exhaust hood installation for standard economizer

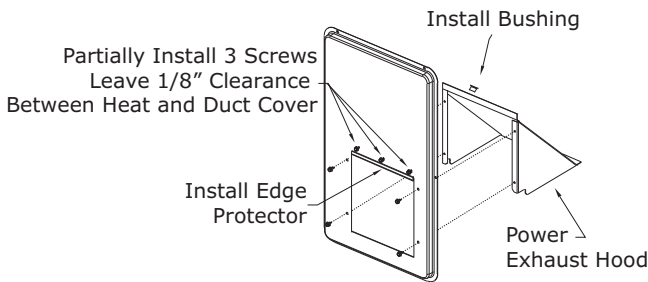

2. Drill four holes through the template and panel for saw cutting starter holes. Likewise, cut through the template and panel at the same time to create the new opening; discard the scrap metal.
3. Install edge protector (supplied) along the down-facing top edge of the new cutout. See [Figure 1](#).
4. Assemble required powered exhaust hood with screws provided as shown in [Figure 1](#).

Note: Assembly kit comes with AB and CD cabinet size parts. Use parts that correspond to unit/return panel size.

5. Mount hood to duct cover with four screws. See [Figure 1](#).
6. Insert 1 inch bushing into hood. See [Figure 1](#).
7. Partially insert screws into the three engagement holes drilled in the duct cover. Leave approximately 1/8 inch gap between the screw head and duct cover. These will act as alignment hangers. See [Figure 1](#).

Important: Remove the return duct block off. Refer to [Figure 2](#).

Figure 2. Duct block off

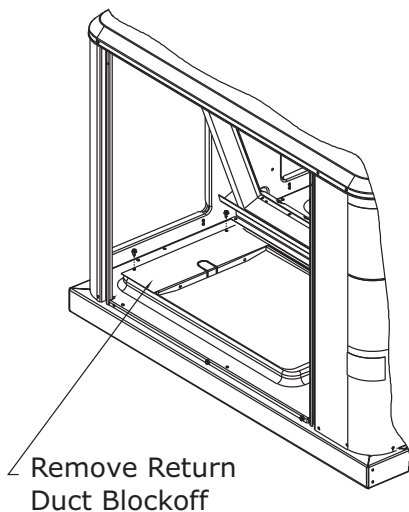

8. Install duct cover back on unit.
9. Apply gasket to face of power exhaust assembly. See [Figure 3](#).

Figure 3. Gasket to power exhaust assembly

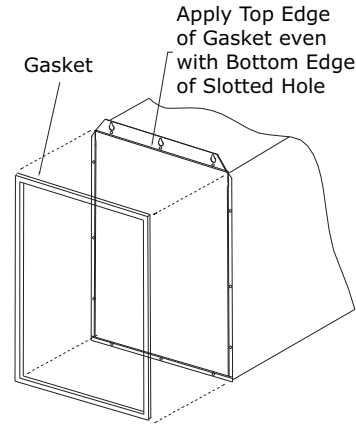

10. Pull wiring harness out from power exhaust assembly and insert through bushing in the hood.
11. Lift power exhaust assembly up and align slots in the top flange with screws in duct cover.
12. Secure the three screws.
13. Use the 7 clearance holes on the perimeter flange and secure to the duct panel with 7 self drilling screws.
14. Route the wire harness along the top edge of the economizer and secure with pop-in wire ties. See [Figure 4](#).

Figure 4. Wire harness routing

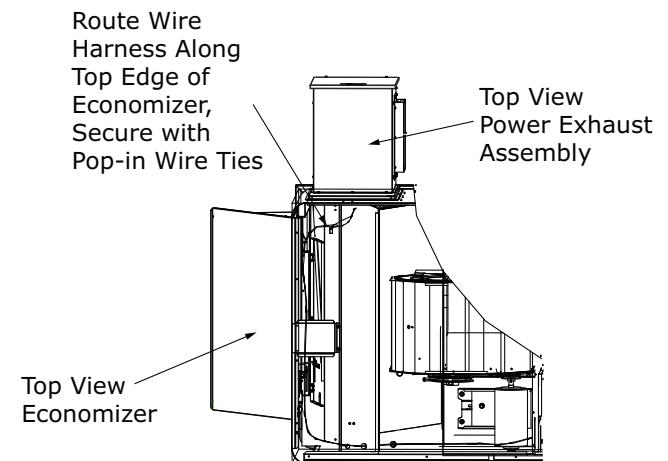

15. Remove all of the screws in the top cover and move it towards the rear of the unit just enough to insert the wire harness wires W42, W43, W65, and W66 for the powered exhaust in the raceway. Route to control box. Refer to [Figure 4](#).

Figure 5. Raceway top view

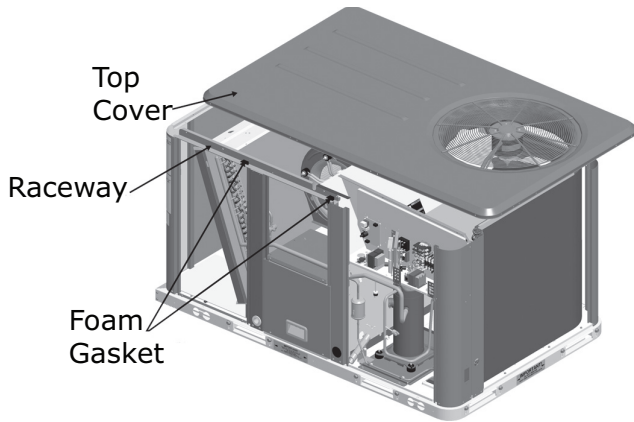

5. Using self-drilling screws, attach powered exhaust perimeter to facing.
6. Take up slack in wire and route clear of gears.

⚠ WARNING

Hazardous Voltage w/Capacitors!

Failure to disconnect power and discharge capacitors before servicing could result in death or serious injury. Disconnect all electric power, including remote disconnects and discharge all motor start/run capacitors before servicing. Follow proper lockout/tagout procedures to ensure the power cannot be inadvertently energized. For variable frequency drives or other energy storing components provided by Trane or others, refer to the appropriate manufacturer's literature for allowable waiting periods for discharge of capacitors. Verify with a CAT III or IV voltmeter rated per NFPA 70E that all capacitors have discharged.

Low Leak Economizer Installation

Figure 6. Low leak install

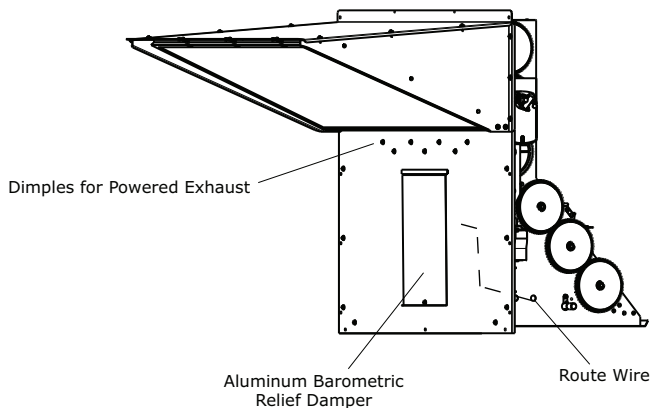

1. Remove barometric relief hood (if installed).
2. Remove aluminum barometric relief damper and discard.
3. Route wire through 1 inch hole to control module.
4. Locate dimples, then hang powered exhaust on three top holes using self-drilling screws. The upper hood may need to be removed to access dimples.

Wiring Installation

⚠ WARNING

Proper Field Wiring and Grounding Required!

Failure to follow code could result in death or serious injury. All field wiring **MUST** be performed by qualified personnel. Improperly installed and grounded field wiring poses **FIRE** and **ELECTROCUTION** hazards. To avoid these hazards, you **MUST** follow requirements for field wiring installation and grounding as described in **NEC** and your local/state/national electrical codes.

NOTICE

Use provided wire ties to make sure wire are secured and protected from sharp edges and hot surfaces.

Note: Inspect existing economizer actuator for necessary logic module connections. ReliaTel™ controlled units may require BAYRTEM001* if the “EXF” connection is not present. See Figure 8. Electromechanical controlled units will require BAYLMSW001* switch kit if the “EXF” connection is not present on the economizer logic module. See Figure 9.

Figure 7. Wiring

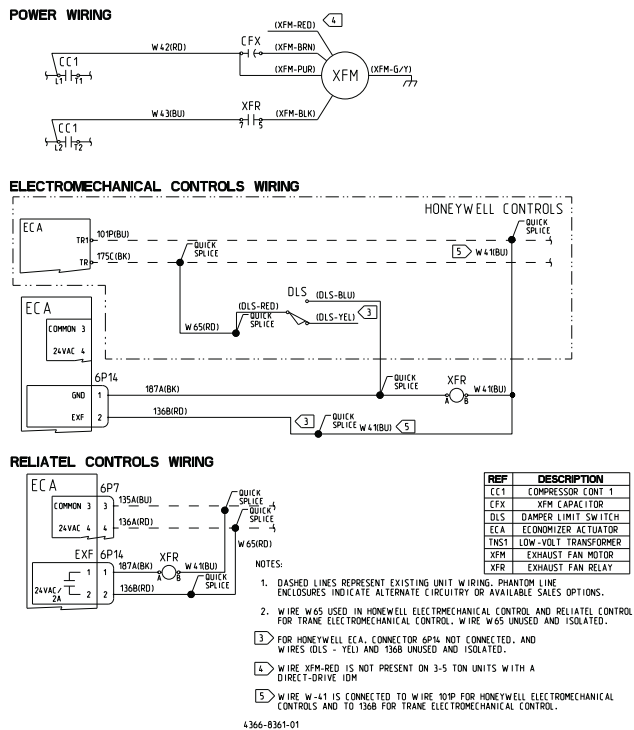

ReliaTel™ Controls Wiring

Refer to ReliaTel™ controls wiring diagram for connections. See Figure 7.

⚠ WARNING

Hazardous Voltage w/Capacitors!

Failure to disconnect power and discharge capacitors before servicing could result in death or serious injury. Disconnect all electric power, including remote disconnects and discharge all motor start/run capacitors before servicing. Follow proper lockout/tagout procedures to ensure the power cannot be inadvertently energized. For variable frequency drives or other energy storing components provided by Trane or others, refer to the appropriate manufacturer's literature for allowable waiting periods for discharge of capacitors. Verify with a CAT III or IV voltmeter rated per NFPA 70E that all capacitors have discharged.

- Remove 6P7 plug from actuator module.
- Using 18 ga. red quick splice connectors provided, splice unit 6P7 plug, wire #135A (BLU) removed from actuator in step 1, to power exhaust wire #W41 (BLU).
- Using 18 ga. red quick splice connector provided, splice unit 6P7 plug, wire #136A (RED) with powered exhaust harness wire #W65 (RED).
- Using 18 ga. red quick splice connector provided, splice powered exhaust harness wire #W65 (RED) with powered exhaust plug 6P14 wire #136B (RED).
- Reconnect 6P7 plug to actuator module.
- Connect power exhaust 6P14 plug, wires #187A and 136B, to EXF on actuator module.

Figure 8. Logic module

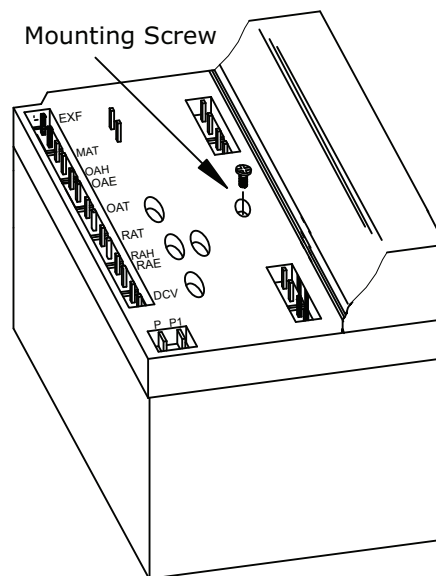

Electromechanical Controls Wiring

Note: If unit has electromechanical controls logic module does not have the “EXF” connection, BAYLMSW001* is required.

Switch Kit Installation

Figure 9. Switch kit installation

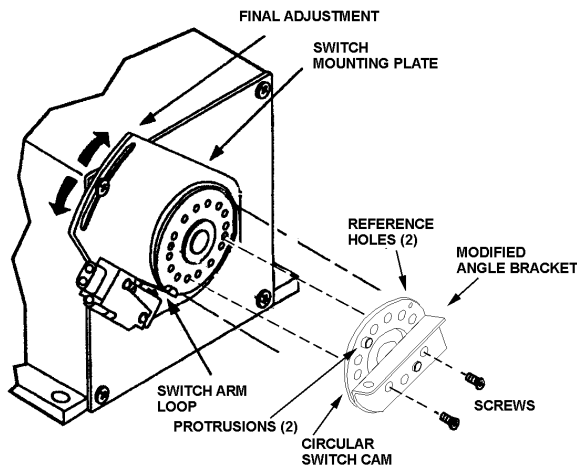

1. Install the Honeywell 4074EKV Auxiliary Switch Kit on the damper actuator motor according to the switch kit instructions except for the following:
 - a. The damper actuator motor does not use the crank arm pictured in the auxiliary switch kit instructions. Instead, an angle bracket is used on the unit. See [Figure 9](#). The unit angle bracket must be replaced with the modified angle bracket, provided with this power exhaust accessory in order for the circular switch cam to operate properly.
 - b. Switch cam orientation and final switch mounting plate adjustments enable the “snap” type limit switch to be set to trip at any damper position between about 20% and 80% open. The 0% to 100% damper actuator motor range of motion is 90 angular degrees. The angle bracket shown in [Figure 9](#) rotates approximately from a 30° angle to a 120° angle as the damper opens.
 - c. Remove the mist eliminator screen for screw access. Observe and record or mark positions and orientations of damper actuator, angle bracket and screws with the damper in the closed position. Then remove the damper actuator from the economizer assembly and remove the existing angle bracket from the actuator.
 - d. After installing the snap switch and the switch mounting plate according to the kit instructions, install the circular switch cam between the damper actuator motor and the modified angle bracket provided with this power exhaust accessory. The two protrusions on the circular switch cam should be oriented away from the actuator

so that one of them engages in one of the two extra holes in the modified angle bracket provided. See [Figure 9](#). This holds the circular switch cam in one of two possible positions.

- e. With the circular switch cam in the desired location, attach the provided modified angle bracket to the actuator per above, using an orientation and screw location identical to the original angle bracket removed from the actuator.
- f. Set the final adjustment of the switch mounting plate as shown in the kit and adjust the snap switch according to the kit instructions and the above, so that it trips and releases at the desired percentage of damper opening. This will be the point at which the power exhaust motor is turned on and off.
- g. Replace the damper actuator motor and mist eliminator on the unit per original installation.

Electromechanical Controls

⚠ WARNING

Hazardous Voltage w/Capacitors!

Failure to disconnect power and discharge capacitors before servicing could result in death or serious injury. Disconnect all electric power, including remote disconnects and discharge all motor start/run capacitors before servicing. Follow proper lockout/tagout procedures to ensure the power cannot be inadvertently energized. For variable frequency drives or other energy storing components provided by Trane or others, refer to the appropriate manufacturer’s literature for allowable waiting periods for discharge of capacitors. Verify with a CAT III or IV voltmeter rated per NFPA 70E that all capacitors have discharged.

Refer to Electromechanical controls wiring diagram ([Figure 7](#)) for connections.

Economizer Logic Module with “EXF” Output (Trane Module)

1. Using 18 ga. red quick splice connector provided, splice powered exhaust harness wire #W41 (BU) with powered exhaust harness plug 6P14 wire #136B (RED).
2. Connect powered exhaust harness plug 6P14 to economizer logic module “EXF” connector.

Economizer Logic Module without “EXF” Output (Honeywell Module)

1. Using provided 18 ga. red quick splice connector, splice powered exhaust harness wire #W41 (BU) with economizer wire harness wire #101P (BU).
2. Using provided 18 ga. red quick splice connector, splice powered exhaust harness plug 6P14 wire #187A (BLK) with DLS auxiliary switch (N.O) blue wire.

Wiring Installation

- Using provided 18 ga. red quick splice connector, splice powered exhaust harness wire #W65 (RED) with DLS auxiliary switch (common) red wire.
- Using provided 18 ga. red quick splice connector, splice powered exhaust harness wire #W65 (RED) with economizer wire harness wire #175C (BK).

Power Wiring

⚠ WARNING

Hazardous Voltage w/Capacitors!

Failure to disconnect power and discharge capacitors before servicing could result in death or serious injury. Disconnect all electric power, including remote disconnects and discharge all motor start/run capacitors before servicing. Follow proper lockout/tagout procedures to ensure the power cannot be inadvertently energized. For variable frequency drives or other energy storing components provided by Trane or others, refer to the appropriate manufacturer's literature for allowable waiting periods for discharge of capacitors. Verify with a CAT III or IV voltmeter rated per NFPA 70E that all capacitors have discharged.

Refer to the power diagrams for connections (Figure 7).

The powered exhaust power wires previously routed to the control box will be connected to the compressor contactor.

- Connect W42 to compressor contactor L1.
- Connect W43 to compressor contactor L2.
- Replace compressor access panel.

Electromechanical Unit Power Exhaust Operation and Settings

Economizer Logic Module with "EXF" Output (Trane Module)

The power exhaust set point (the point at which the power exhaust is turned on) is adjustable from 0% to 100% economizer damper outside air setting, corresponding to the setting of the "EXF SETPOINT" Potentiometer on the economizer logic module. The power exhaust is turned on when the indoor blower is running and the damper position is greater than the power exhaust set point.

Economizer Logic Module without "EXF" Output (Honeywell Module)

The power exhaust operates whenever the indoor blower is running and the economizer damper is open sufficiently to trip the snap switch (adjustable from 20% to 80%). Power exhaust will operate based on auxiliary switch settings on the economizer actuator.

ReliaTel™ Unit Power Exhaust Operation and Settings

Units without a ReliaTel™ Options Module (RTOM)

The power exhaust is turned on whenever the indoor blower is running and the economizer damper is at 25% outside air or greater. This is not adjustable.

ReliaTel™ Units with an RTOM and without Ventilation Override Accessory

The power exhaust set point (the point at which the power exhaust is turned on) is adjustable from 0% to 100% economizer damper outside air setting, corresponding to the setting of the "exhaust setpoint" potentiometer on the RTOM (see Figure 10). The power exhaust is turned on when the indoor blower is running and the damper position is greater than the power exhaust set point.

ReliaTel™ Units with an RTOM and with an Optional Ventilation Override Accessory

Same as above except ventilation override exhaust function causes power exhaust to run with damper closed and indoor blower off.

Figure 10. Power exhaust potentiometer

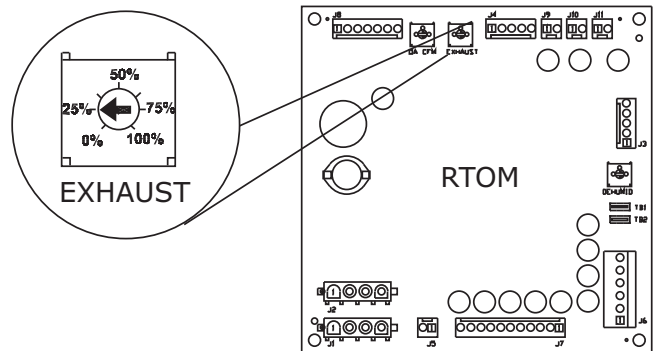

- Close unit disconnect, then place the zone sensor fan selector in the Fan "ON" position, and the Heat/Cool selector in the "OFF" position. This places the damper in the minimum ventilation position.
- On ReliaTel™ units, to verify power exhaust operation, put unit in test mode and step through to economizer step. Adjust power exhaust initiate point as desired.

Note: ReliaTel™ units without RTOM option, power exhaust will not come on until economizer damper reaches approximately 25% open. ReliaTel™ units with RTOM option, power exhaust will operate based on exhaust setpoint on RTOM module.

Close Out Installation

⚠ WARNING

Hazardous Voltage w/Capacitors!

Failure to disconnect power and discharge capacitors before servicing could result in death or serious injury. Disconnect all electric power, including remote disconnects and discharge all motor start/run capacitors before servicing. Follow proper lockout/tagout procedures to ensure the power cannot be inadvertently energized. For variable frequency drives or other energy storing components provided by Trane or others, refer to the appropriate manufacturer's literature for allowable waiting periods for discharge of capacitors. Verify with a CAT III or IV voltmeter rated per NFPA 70E that all capacitors have discharged.

1. Open and lock unit disconnect.
2. Replace the filter access panel at this time.
3. Place the 1 inch x 3 inches label (power exhaust installed) next to the main unit wiring diagram inside the compressor access panel.
4. Before leaving the installation, check all seams on the power exhaust and ensure they are all sealed water-tight with caulk provided.
5. Close the unit disconnect switch.

Trane and American Standard create comfortable, energy efficient indoor environments for commercial and residential applications. For more information, please visit trane.com or americanstandardair.com.

Trane and American Standard have a policy of continuous product and product data improvement and reserve the right to change design and specifications without notice. We are committed to using environmentally conscious print practices.