



Installation, Operation, and Maintenance

Water Source Heat Pump Axiom™

High Efficiency Console

0.5 to 1.5 Tons — 60 Hz



Model Numbers:

GEC* 006, 009, 012, 015, 018 (60 Hz)

⚠ SAFETY WARNING

Only qualified personnel should install and service the equipment. The installation, starting up, and servicing of heating, ventilating, and air-conditioning equipment can be hazardous and requires specific knowledge and training. Improperly installed, adjusted or altered equipment by an unqualified person could result in death or serious injury. When working on the equipment, observe all precautions in the literature and on the tags, stickers, and labels that are attached to the equipment.



Introduction

Read this manual thoroughly before operating or servicing this unit.

Warnings, Cautions, and Notices

Safety advisories appear throughout this manual as required. Your personal safety and the proper operation of this machine depend upon the strict observance of these precautions.

The three types of advisories are defined as follows:



Indicates a potentially hazardous situation which, if not avoided, could result in death or serious injury.



Indicates a potentially hazardous situation which, if not avoided, could result in minor or moderate injury. It could also be used to alert against unsafe practices.



Indicates a situation that could result in equipment or property-damage only accidents.

Important Environmental Concerns

Scientific research has shown that certain man-made chemicals can affect the earth's naturally occurring stratospheric ozone layer when released to the atmosphere. In particular, several of the identified chemicals that may affect the ozone layer are refrigerants that contain Chlorine, Fluorine and Carbon (CFCs) and those containing Hydrogen, Chlorine, Fluorine and Carbon (HCFCs). Not all refrigerants containing these compounds have the same potential impact to the environment. Trane advocates the responsible handling of all refrigerants.

Important Responsible Refrigerant Practices

Trane believes that responsible refrigerant practices are important to the environment, our customers, and the air conditioning industry. All technicians who handle refrigerants must be certified according to local rules. For the USA, the Federal Clean Air Act (Section 608) sets forth the requirements for handling, reclaiming, recovering and recycling of certain refrigerants and the equipment that is used in these service procedures. In addition, some states or municipalities may have additional requirements that must also be adhered to for responsible management of refrigerants. Know the applicable laws and follow them.

⚠ WARNING

Proper Field Wiring and Grounding Required!

Failure to follow code could result in death or serious injury.

All field wiring **MUST** be performed by qualified personnel. Improperly installed and grounded field wiring poses **FIRE** and **ELECTROCUTION** hazards. To avoid these hazards, you **MUST** follow requirements for field wiring installation and grounding as described in **NEC** and your local/state/national electrical codes.

⚠ WARNING

Personal Protective Equipment (PPE) Required!

Failure to wear proper PPE for the job being undertaken could result in death or serious injury.

Technicians, in order to protect themselves from potential electrical, mechanical, and chemical hazards, **MUST** follow precautions in this manual and on the tags, stickers, and labels, as well as the instructions below:

- **Before installing/servicing this unit, technicians MUST put on all PPE required for the work being undertaken (Examples; cut resistant gloves/sleeves, butyl gloves, safety glasses, hard hat/bump cap, fall protection, electrical PPE and arc flash clothing). ALWAYS refer to appropriate Safety Data Sheets (SDS) and OSHA guidelines for proper PPE.**
- **When working with or around hazardous chemicals, ALWAYS refer to the appropriate SDS and OSHA/GHS (Global Harmonized System of Classification and Labelling of Chemicals) guidelines for information on allowable personal exposure levels, proper respiratory protection and handling instructions.**
- **If there is a risk of energized electrical contact, arc, or flash, technicians MUST put on all PPE in accordance with OSHA, NFPA 70E, or other country-specific requirements for arc flash protection, PRIOR to servicing the unit. NEVER PERFORM ANY SWITCHING, DISCONNECTING, OR VOLTAGE TESTING WITHOUT PROPER ELECTRICAL PPE AND ARC FLASH CLOTHING. ENSURE ELECTRICAL METERS AND EQUIPMENT ARE PROPERLY RATED FOR INTENDED VOLTAGE.**

⚠ WARNING**Follow EHS Policies!**

Failure to follow instructions below could result in death or serious injury.

- All Trane personnel must follow the company's Environmental, Health and Safety (EHS) policies when performing work such as hot work, electrical, fall protection, lockout/tagout, refrigerant handling, etc. Where local regulations are more stringent than these policies, those regulations supersede these policies.
- Non-Trane personnel should always follow local regulations.

⚠ WARNING**R-454B Flammable A2L Refrigerant!**

Failure to use proper equipment or components as described below could result in equipment failure, and possibly fire, which could result in death, serious injury, or equipment damage.

The equipment described in this manual uses R-454B refrigerant which is flammable (A2L). Use ONLY R-454B rated service equipment and components. For specific handling concerns with R-454B, contact your local representative.

⚠ WARNING**Electrical Shock Hazard!**

Failure to follow instructions below could result in death or serious injury.

Properly connect the system's oversized protective earthing (grounding) terminal(s).

Copyright

This document and the information in it are the property of Trane, and may not be used or reproduced in whole or in part without written permission. Trane reserves the right to revise this publication at any time, and to make changes to its content without obligation to notify any person of such revision or change.

Trademarks

All trademarks referenced in this document are the trademarks of their respective owners.

Product Safety Information

This appliance is not intended for use by persons (including children) with reduced physical, sensory or mental capabilities, or lack of experience and knowledge, unless they have been given supervision or instruction concerning use of the appliance by a person responsible for their safety. Children should be supervised to ensure that they do not play with the appliance.

Maximum altitude of use 3000 meters.

This appliance incorporates an earth connection for functional purposes only.



Table of Contents

Model Number Description	5	Electrical Data	30
General Information	6	Pre-Start Checklist.....	32
Jobsite Inspection	6	Start-Up.....	33
Job Storage	6	Initial Unit Start-up	33
Operating Limits.....	7	Start-up Checklist and Log	33
Unit Dimensions	8	Operating Pressures	33
Service Clearances	8	Water Pressure Drop.....	35
Weights	22	Water Volume	36
A2L Information	23	Maintenance	37
A2L Work Procedures	23	Preventive Maintenance.....	37
Servicing	23	Filter Replacement (Standard Height Configuration).....	37
Leak Detection	24	Filter Replacement (Low Height Configuration).....	37
Refrigerant Removal and Evacuation.....	24	Troubleshooting	38
Refrigerant Charging	24	Deluxe 24V Controls	38
Decommissioning	25	Wiring Diagrams.....	41
A2L Application Considerations.....	25	Warranty	44
Ignition Sources in Ductwork.....	25	Standard Warranty.....	44
Ignition Sources in Unit	26	Extended Warranty	44
Minimum Room Area Limits (Refrigerant charge greater than 3.91 lb per circuit)	26		
Leak Detection System(Refrigerant charge greater than 3.91 lb per circuit).....	27		
Installation	28		



Model Number Description

Digit 1, 2, 3 — Unit Configuration

GEC = High Efficiency Console

Digit 4 — Unit Configuration

K = R-454B

Digit 5, 6, 7 — Nominal Capacity

006 = 0.5 Tons

009 = 0.75 Tons

012 = 1 Tons

015 = 1.25 Tons

018 = 1.5 Tons

Digit 8 — Voltage Volts/Hz/Phase

1 = 208/60/1

2 = 230/60/1

7 = 265/60/1

Digit 9 — Heat Exchanger

1 = Copper-Water Coil

2 = Cupro-Nickel Water Coil

Digit 10 — Design Sequence

A

Digit 11 — Refrigeration Circuit

0 = Heating and Cooling Circuit

2 = Heating and Cooling Circuit with Hot Gas Reheat

Digit 12 — Blower Configuration

1 = Standard Blower Motor

Digit 13 — Freeze Protection

A = 20° Freezestat (For Glycol Loop) (Extended Range Geothermal)

B = 35° Freezestat (For Water Loop)

Digit 14 — Open Digit

0 = Open Digit

S = Design Special

Digit 15 — Supply-Air Arrangement

0 = Standard Supply-Air Arrangement

Digit 16 — Return-Air Arrangement

0 = Standard Return-Air Arrangement

Digit 17 — Control Types

D = Deluxe 24V Controls

E = Deluxe 24V Control with Programmable Thermostat

H = Symbio™ 400-B

J = Symbio 400-B with Air-Fi® Wireless Communications

Digit 18 — Tstat/Sensor Location

0 = Wall Mounted Location

1 = Unit Mounted Location with Standard Entry

2 = Unit Mounted Location with Keylock Entry

Digit 19 — Fault Sensors

1 = Condensate Overflow Sensor

3 = Condensate Overflow and Filter Maintenance Timer

6 = Condensate Overflow and Fan Status

J = Condensate Overflow Sensor, Fan Status and Filter Maintenance Timer

Digit 20 — Temperature Sensor

0 = No Additional Temperature Sensor

1 = Entering Water Sensor

Digit 21 — Open Digit

0 = Open Digit

Digit 22 — Electric Heat

0 = No Electric Heat

2 = Boilerless Control Electric Heat (minimum)

3 = Boilerless Control Electric Heat (maximum)

Digit 23 — Unit Mounted Disconnect

0 = No Unit Mounted Disconnect

A = Power Cord/Receptacle Box

B = Power Cord/Receptacle Box with Circuit Breaker

C = On/Off Toggle Switch

Digit 24 — Filter Type

0 = No Filter; Chassis Only

1 = 1-inch Throwaway Filter

A = 1-inch MERV 8 Filter

Digit 25 — Acoustic Arrangement

0 = Enhanced Sound Attenuation

Digit 26 — Factory Configuration

0 = Standard Factory Configuration (Chassis, Cabinet, and Subbase)

2 = Low Height Factory Configuration (Chassis, Cabinet, and Subbase)

3 = Extended Length Factory Configuration (Chassis, Cabinet, and Subbase)

4 = Low Height Factory Configuration Retrofit (Chassis, Subbase)

5 = Standard Height Factory Configuration Retrofit (Chassis, Subbase)

Digit 27 — Paint Color

0 = No Paint Selection Available

1 = Deluxe Beige

2 = Cameo White

3 = Soft Dove

Digit 28 — Outside Air

0 = No Outside Air Option

1 = Outside Air Opening

2 = Motorized Outside Air (2-position)

Digit 29 — Piping Arrangement

L = Left Hand Piping Arrangement

R = Right Hand Piping Arrangement

Digit 30, 31, 32, 33, 34, 35, 36 — Does Not Apply to GEC

000000 = Digits 30-36 are not applicable to the GEC product



General Information

Jobsite Inspection

Each unit has been inspected, tested and operated at the factory by production and quality associates prior to being crated for safe transit. However, rough handling or accidents can occur resulting in damaged equipment being delivered.

Always perform the following checks before accepting a unit:

- Do not sign the bill of lading accepting the unit(s) until inspection has been completed. Check for damage promptly after the unit(s) are unloaded. Once the bill of lading is signed at the jobsite, the unit(s) are now the property of the SOLD TO party and future freight claims MAY NOT be accepted by the freight company.
- Check the unit model numbers on the bill of lading against those ordered and received to assure equipment is AS ORDERED.
- Check that the refrigerant charge has been retained during shipment by use of gauges. Schrader taps are located and labeled internal to the cabinet.

Figure 1. Schrader location

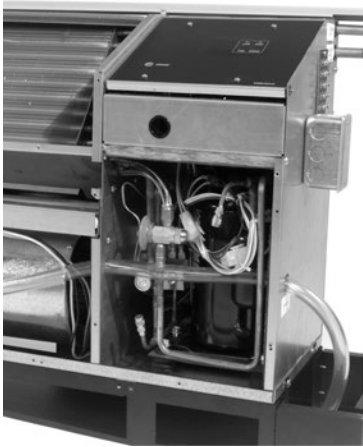

Important: Verify the charge has been retained. Then, reinstall schrader caps to confirm refrigerant leakage does not occur.

Re-install the unit panel using all factory provided screws.

Job Storage

NOTICE

Microbial Growth!

Failure to follow instructions below could result in odors and damage to the equipment and building materials.

Wet interior unit insulation can become an amplification site for microbial growth (mold). If there is evidence of microbial growth on the interior insulation, it should be removed and replaced prior to operating the system.

NOTICE

Microbial Growth!

Failure to follow instructions below could result in odors and damage to the equipment and building materials.

The floor or foundation must be level and the condensate drain at the proper height for proper drainage and condensate flow. Standing water and wet surfaces inside the equipment can become an amplification site for microbial growth (mold). If there is evidence of microbial growth on the interior insulation, it should be removed and replaced prior to operating the system.

This unit is intended for indoor use only. To protect the unit from damage due to the elements, and to prevent possible IAQ contaminant sources from growing, the unit should be stored indoors. If indoor storage is not possible, the following provisions for outdoor storage must be met.

- Place the unit(s) on a dry surface or raise above the ground to assure adequate air circulation beneath the unit. This is to assure that no portion of the unit contacts standing water at any time.
- Cover the unit(s) with a water proof tarp to protect them from the elements.
- Make provisions for continuous venting of the covered units to prevent moisture from standing on the unit(s) surfaces. Wet interior unit insulation can become an amplification site for microbial growth which has been determined to be a cause of odors and serious health related indoor air quality problems.
- Store units in the normal UP orientation. Storing units in this manner maintains oil in the compressor.
- Units may be stacked two high.

Important: Equipment is shipped FOB (Free on Board) at the manufacturer. Therefore, freight claims for damages against the carrier must be initiated by the receiver.

Operating Limits

Table 1. Operating limits

Operating Limits	Cooling	Heating
Air Limits		
Min. ambient air DB	45°F (7°C)	
Max. ambient air DB	130°F (54.4°C)	
Min. EAT DB/WB	65.6/49.4°F (18.7/9.7°C)	53.0°F/- (11.7°C/-)
Max. EAT DB/WB	85.6/77.1°F (29.8/25.1°C)	83.0°F/- (28.3°C/-)
Airflow range	307 to 580 CFM/ton ^(a)	
Water Limits		
Min. entering water temperature	45°F (7°C)	25°F (-4°C)
Max. entering water temperature	120°F (49°C)	86°F (30°C)
Max. water pressure	400 PSIG (2758 kPa)	
Water flow range	1.8 to 4.0 GPM/ton ^(a)	

^(a) See performance tables for each model's rated values.



Unit Dimensions

Service Clearances

Access to the unit for servicing purposes should be provided at installation. All configurations require clearance

from other mechanical and electrical equipment on three service sides (shown below). This enables panel removal from the unit for service/maintenance ability.

Figure 2. Clearances - GEC 0.5 to 1.5 tons

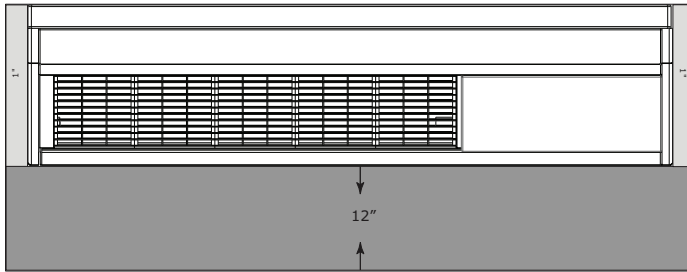

Figure 3. GEC 0.5 to 1.5 tons (60 Hz) - cabinet (RH) piping connection

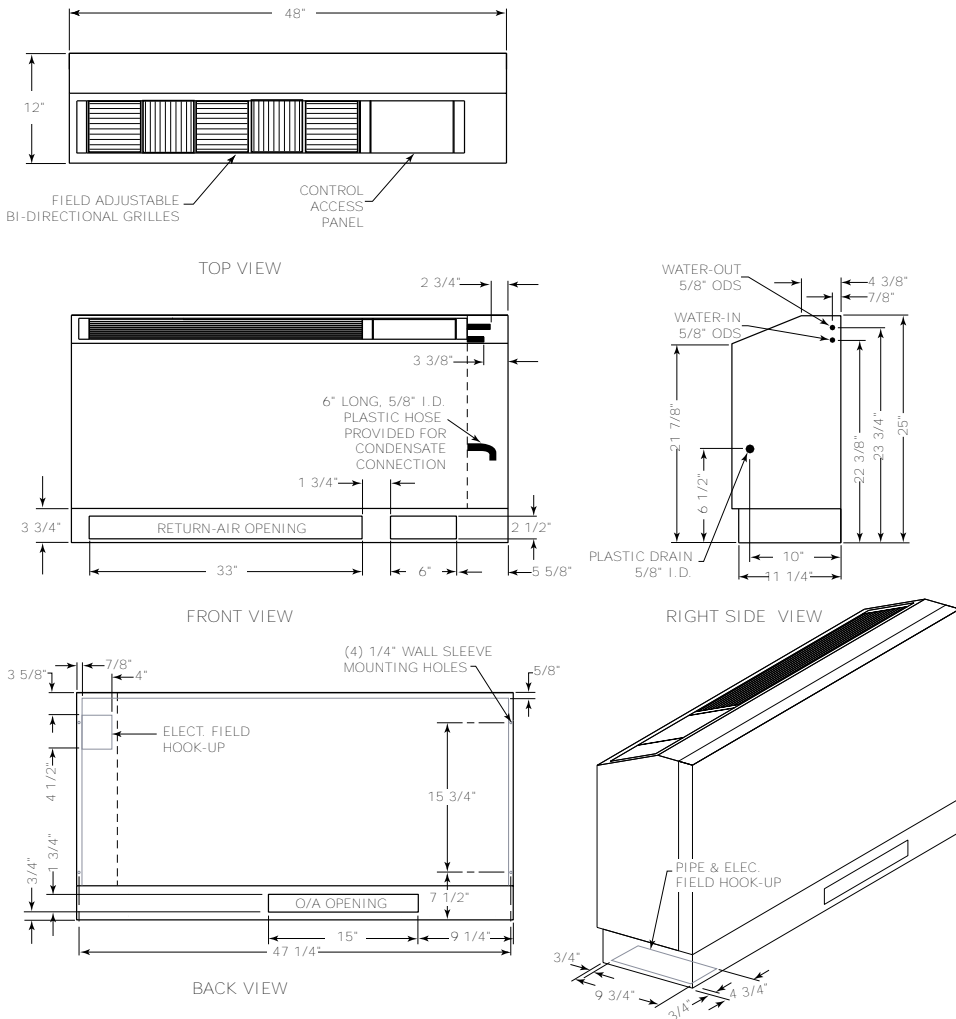
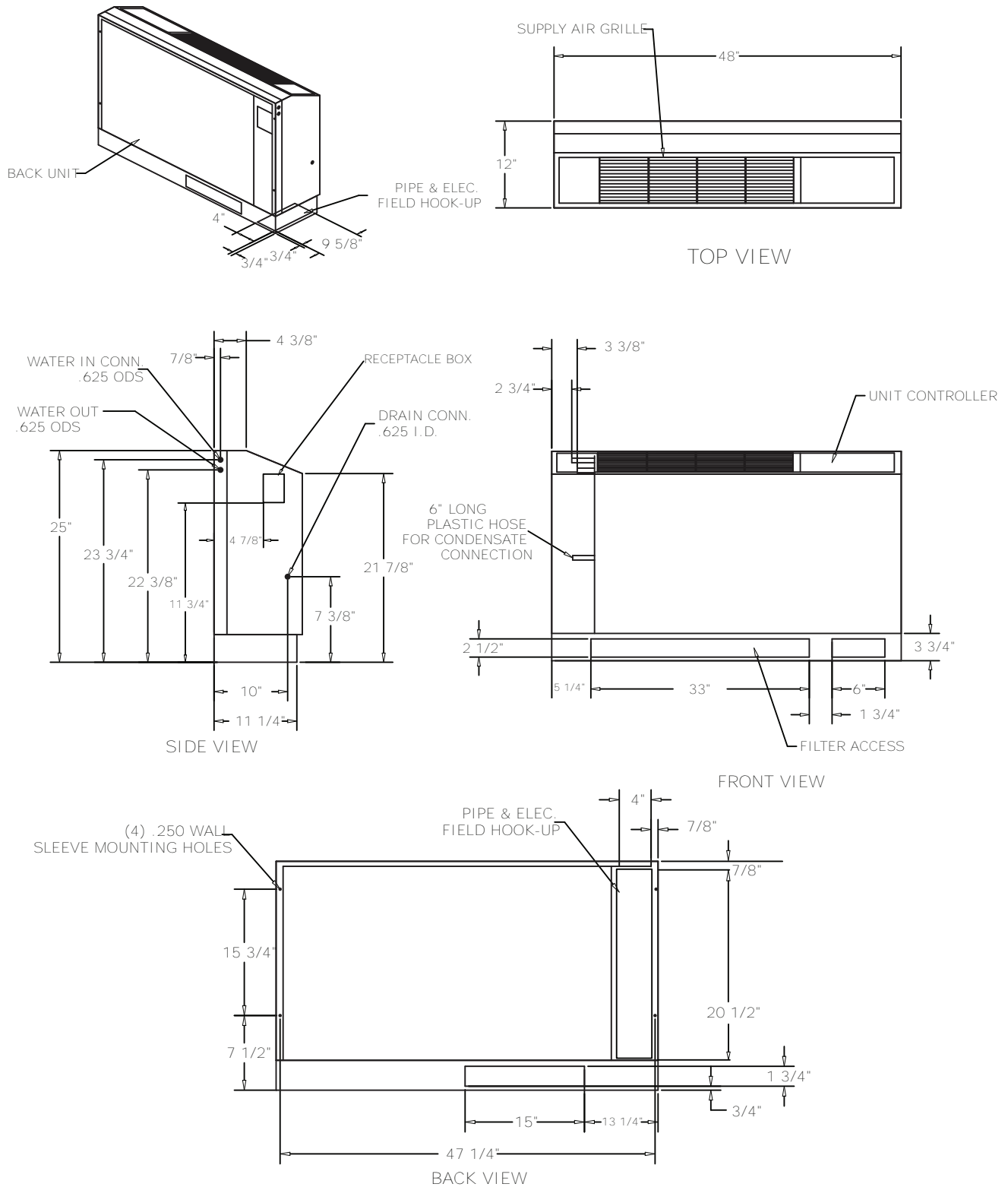

Figure 4. GEC 0.5 to 1.5 tons (60 Hz) - cabinet (LH) piping connection





Unit Dimensions

Figure 5. GEC 0.5 to 1.5 tons (60 Hz) - subbase (RH)

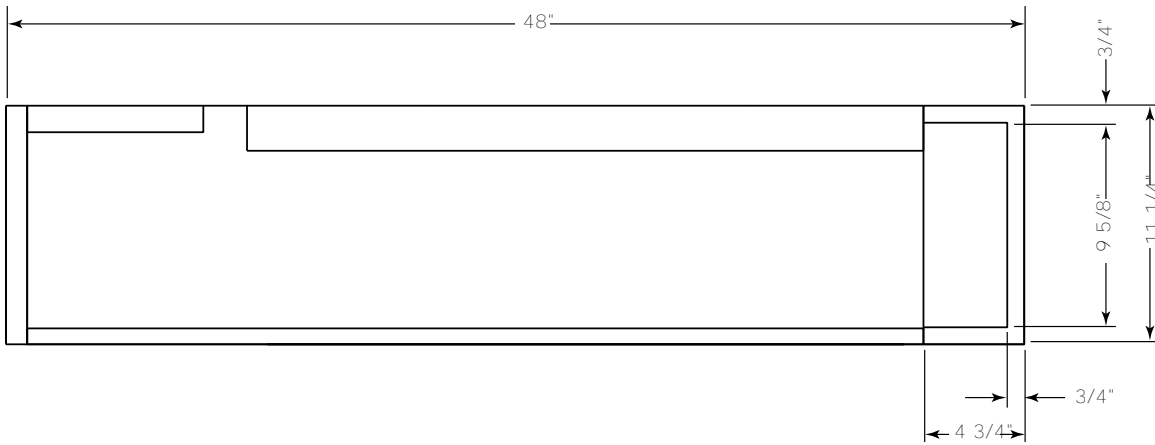

TOP VIEW

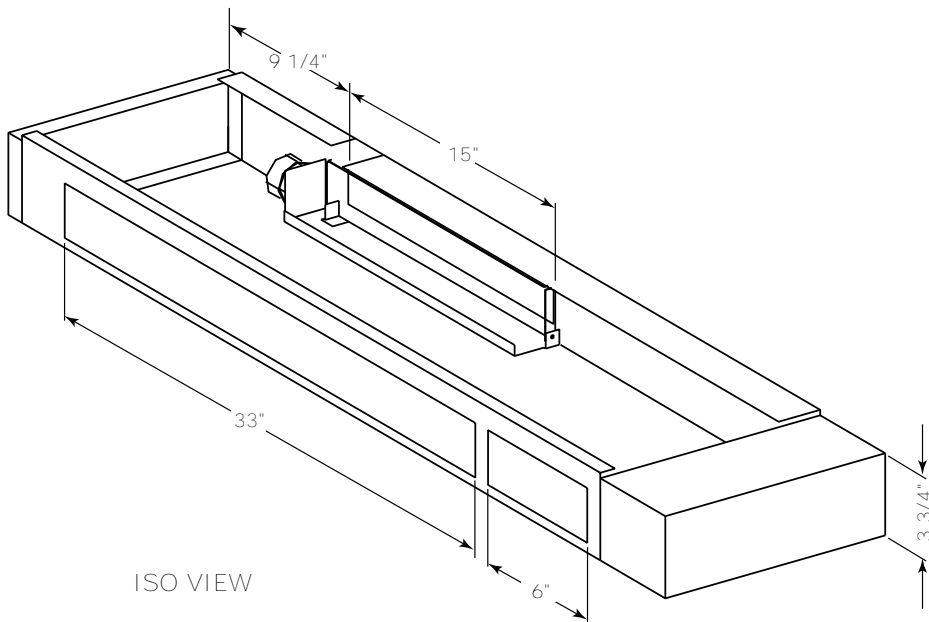

ISO VIEW

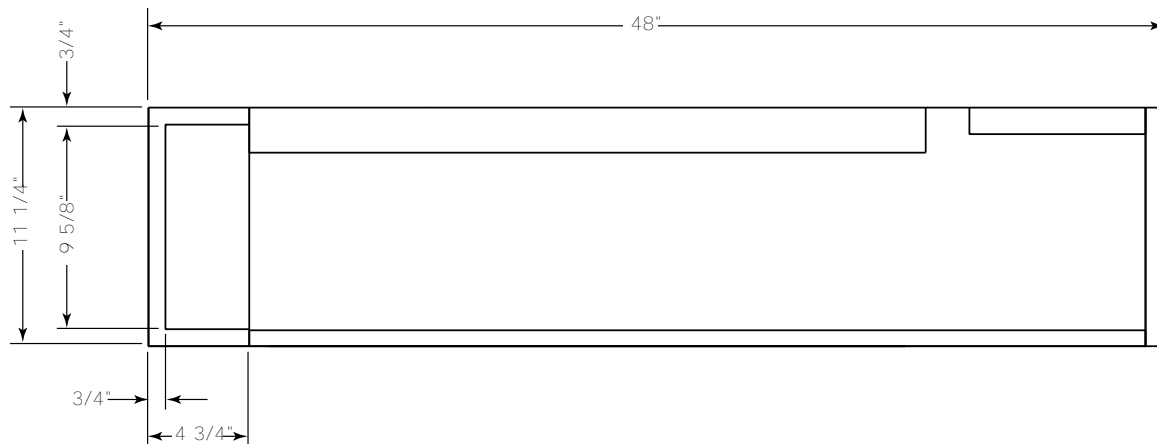
Figure 6. GEC 0.5 to 1.5 tons (60 Hz) - subbase (LH)

TOP VIEW

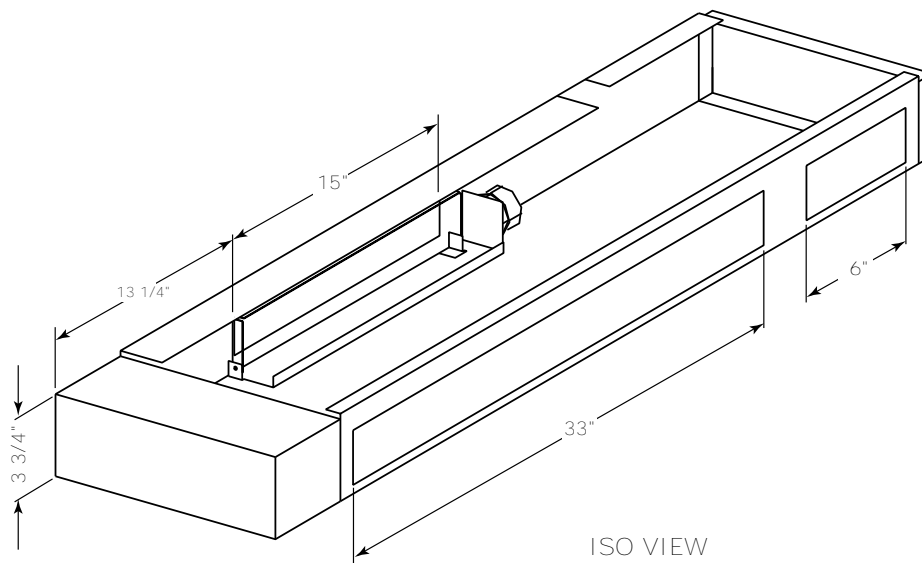

ISO VIEW



Unit Dimensions

Figure 7. GEC 0.5 to 1.5 tons (60 Hz) - cabinet (RH) piping extended length

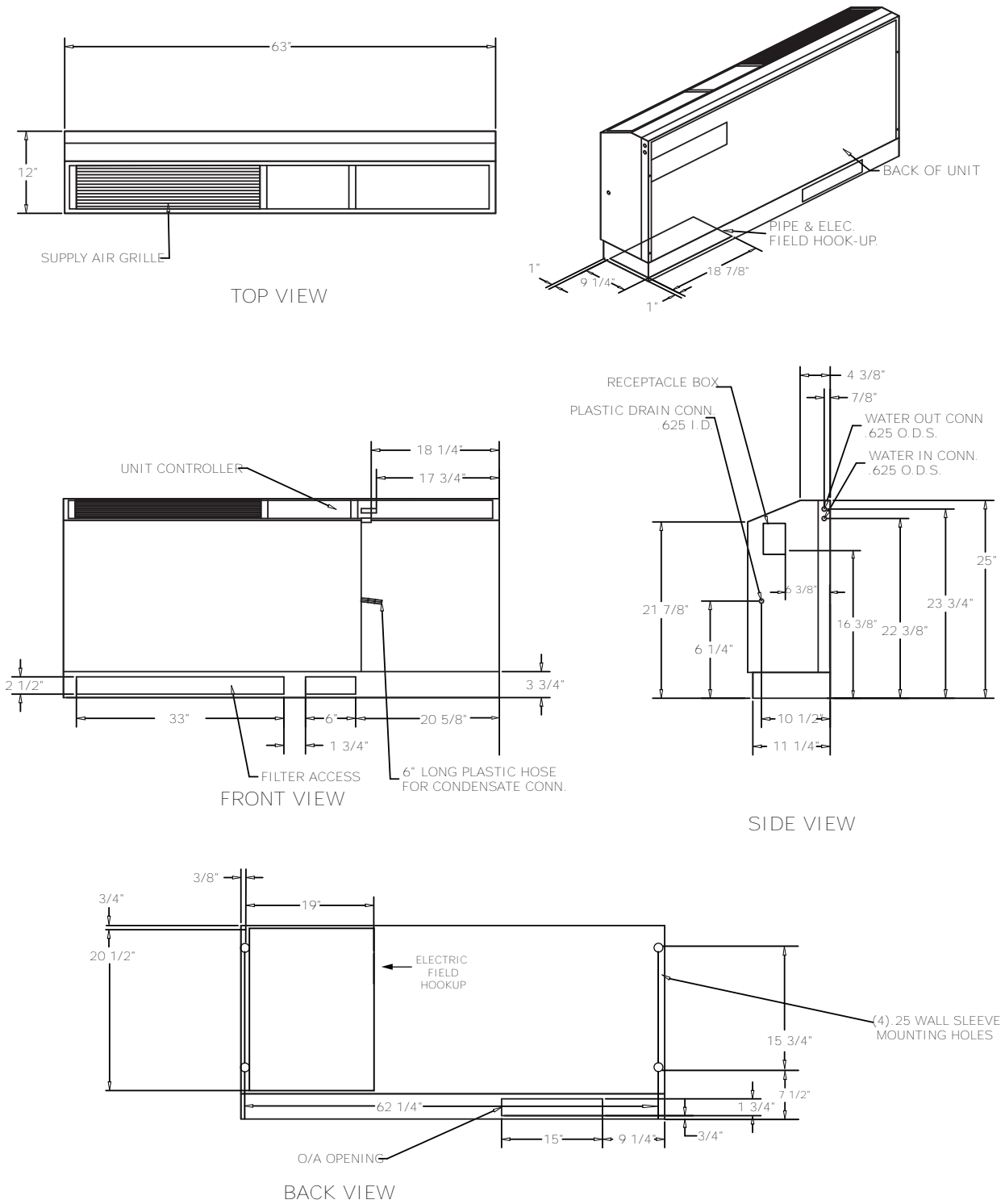
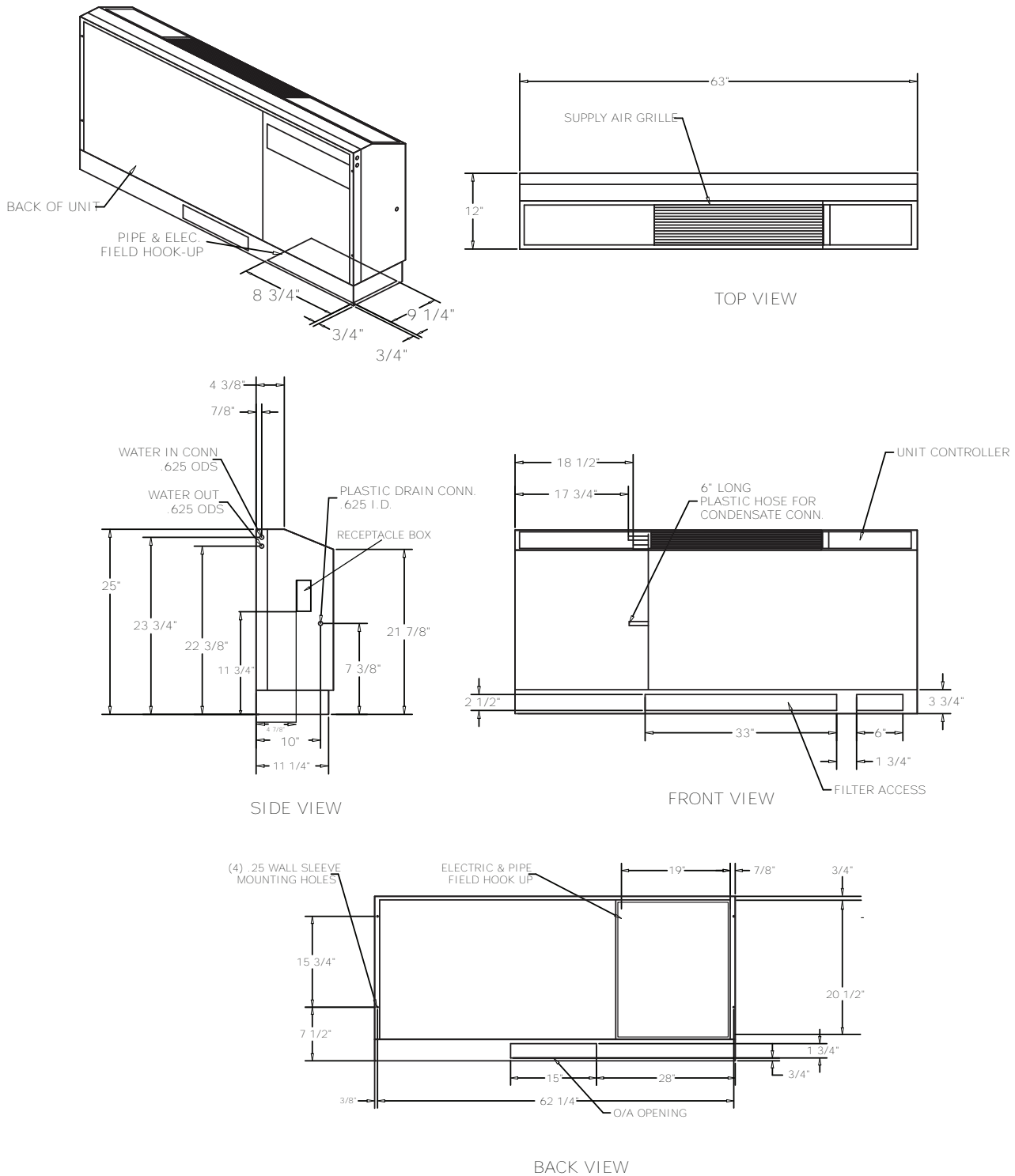

Figure 8. GEC 0.5 to 1.5 tons (60 Hz) - cabinet (LH) piping extended length





Unit Dimensions

Figure 9. GEC 0.5 to 1.5 tons (60 Hz) - subbase (RH) extended length



TOP VIEW

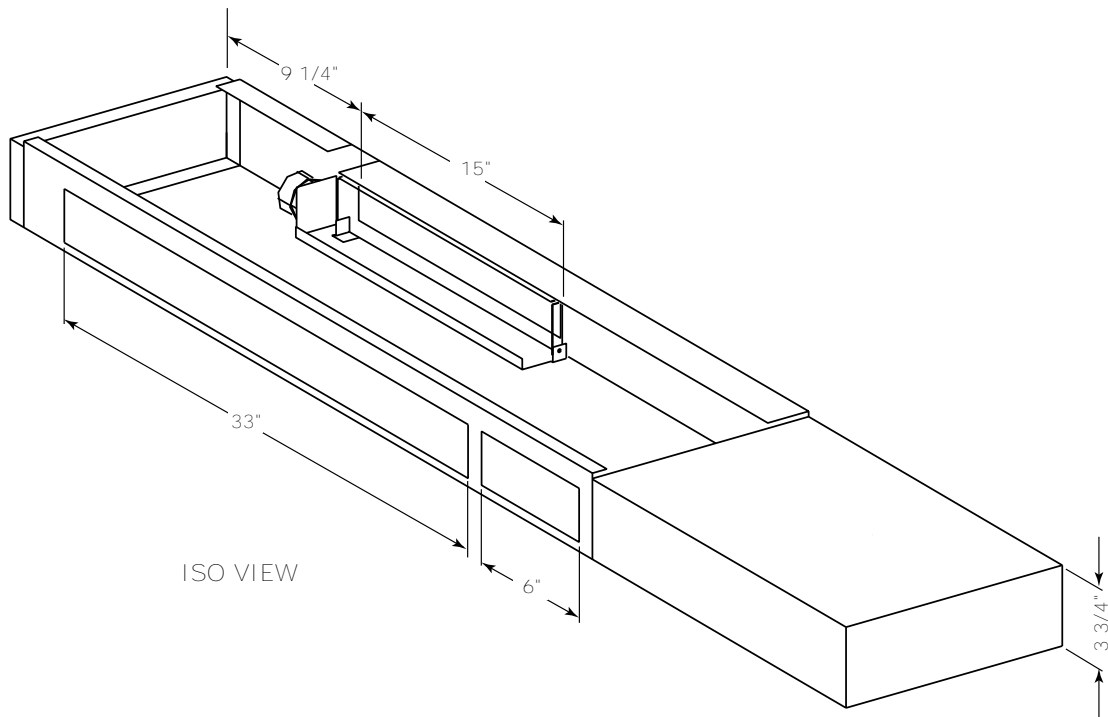

ISO VIEW

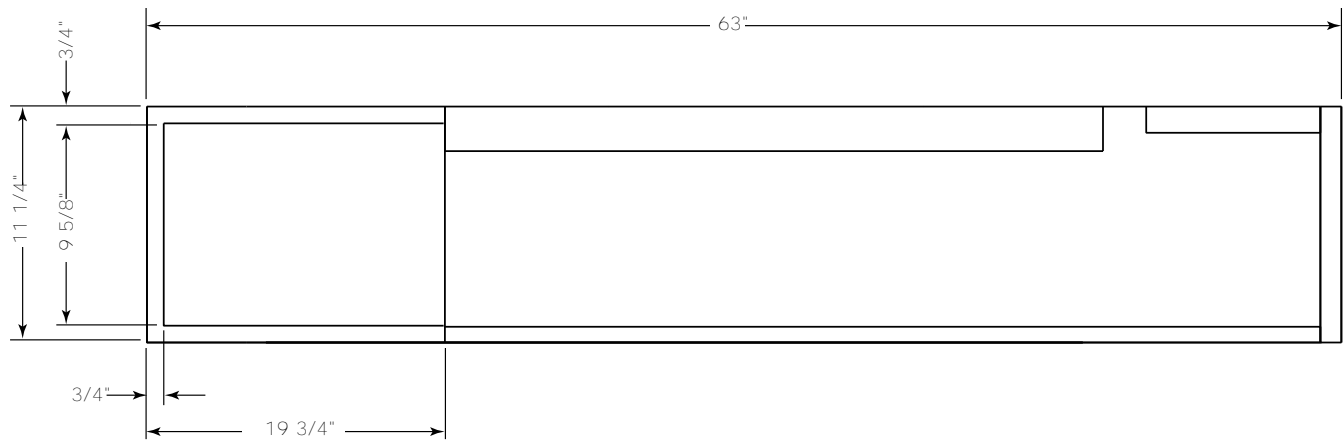
Figure 10. GEC 0.5 to 1.5 tons (60 Hz) - subbase (LH) extended length

TOP VIEW

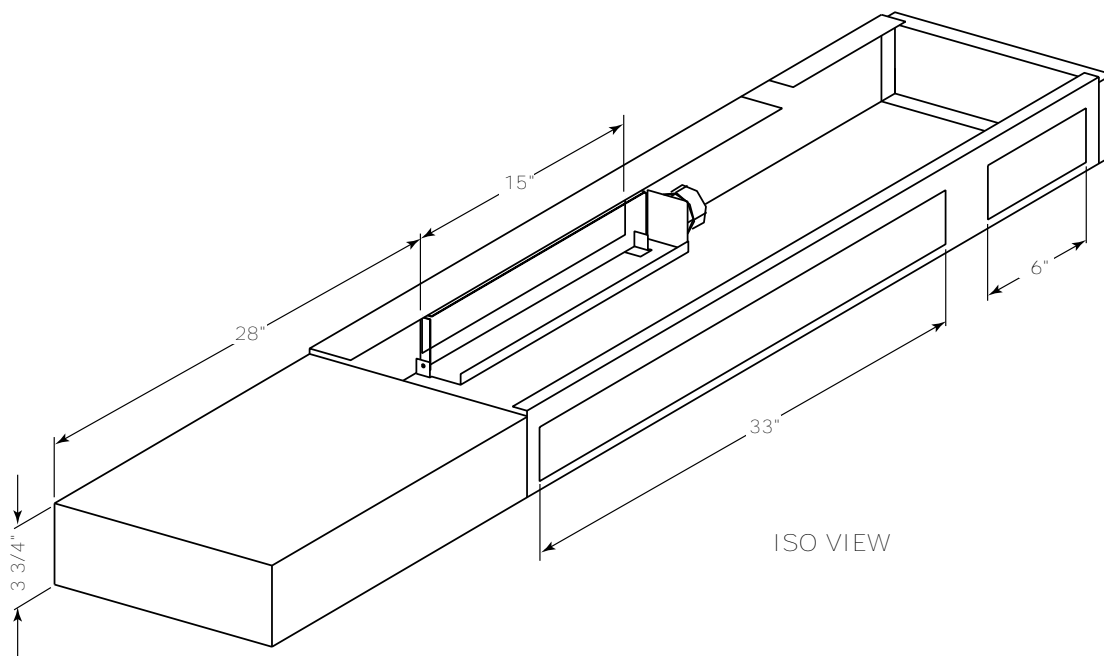

ISO VIEW



Unit Dimensions

Figure 11. GEC 0.5 to 1.5 tons (60 Hz) - cabinet (RH) low height unit

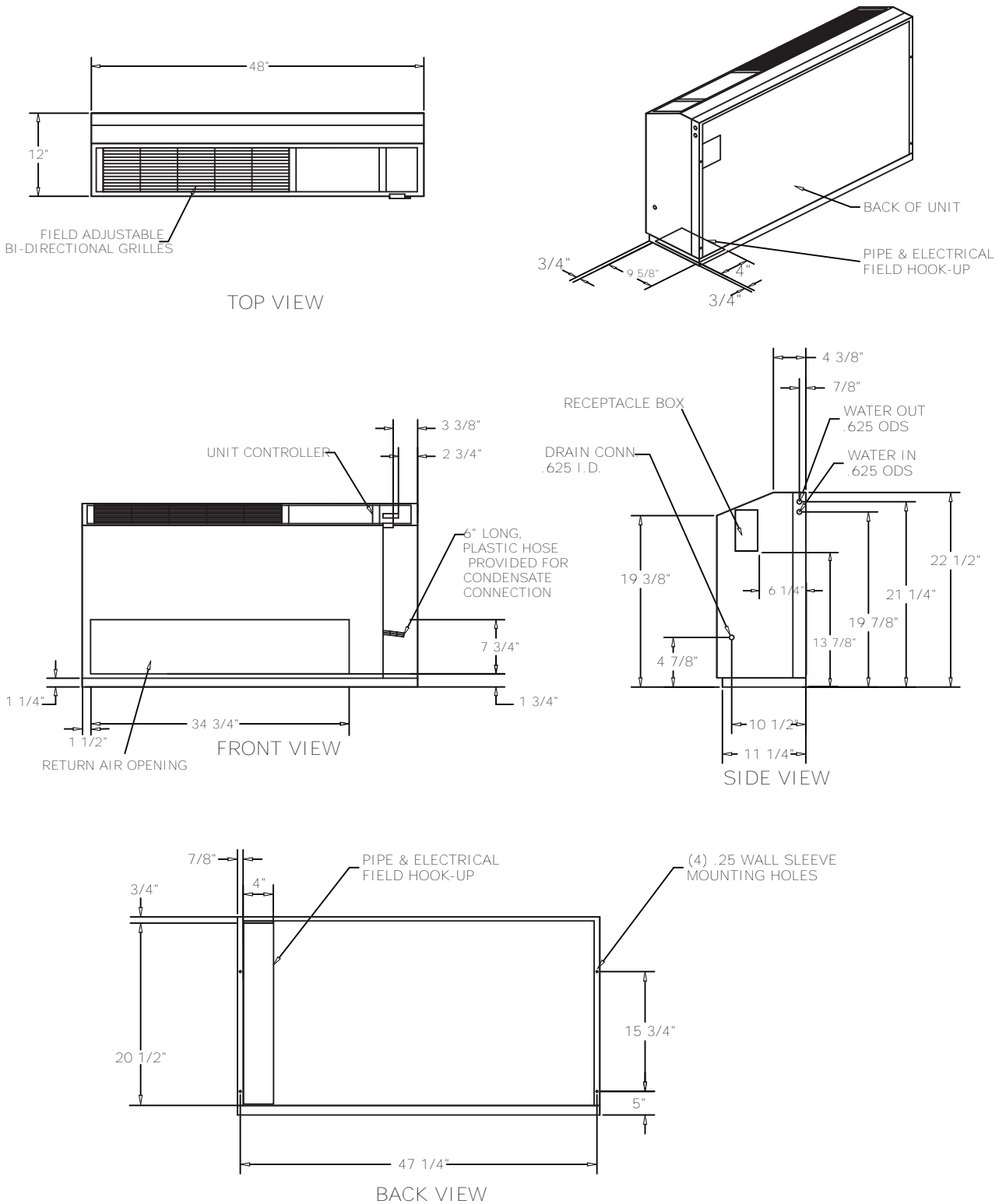
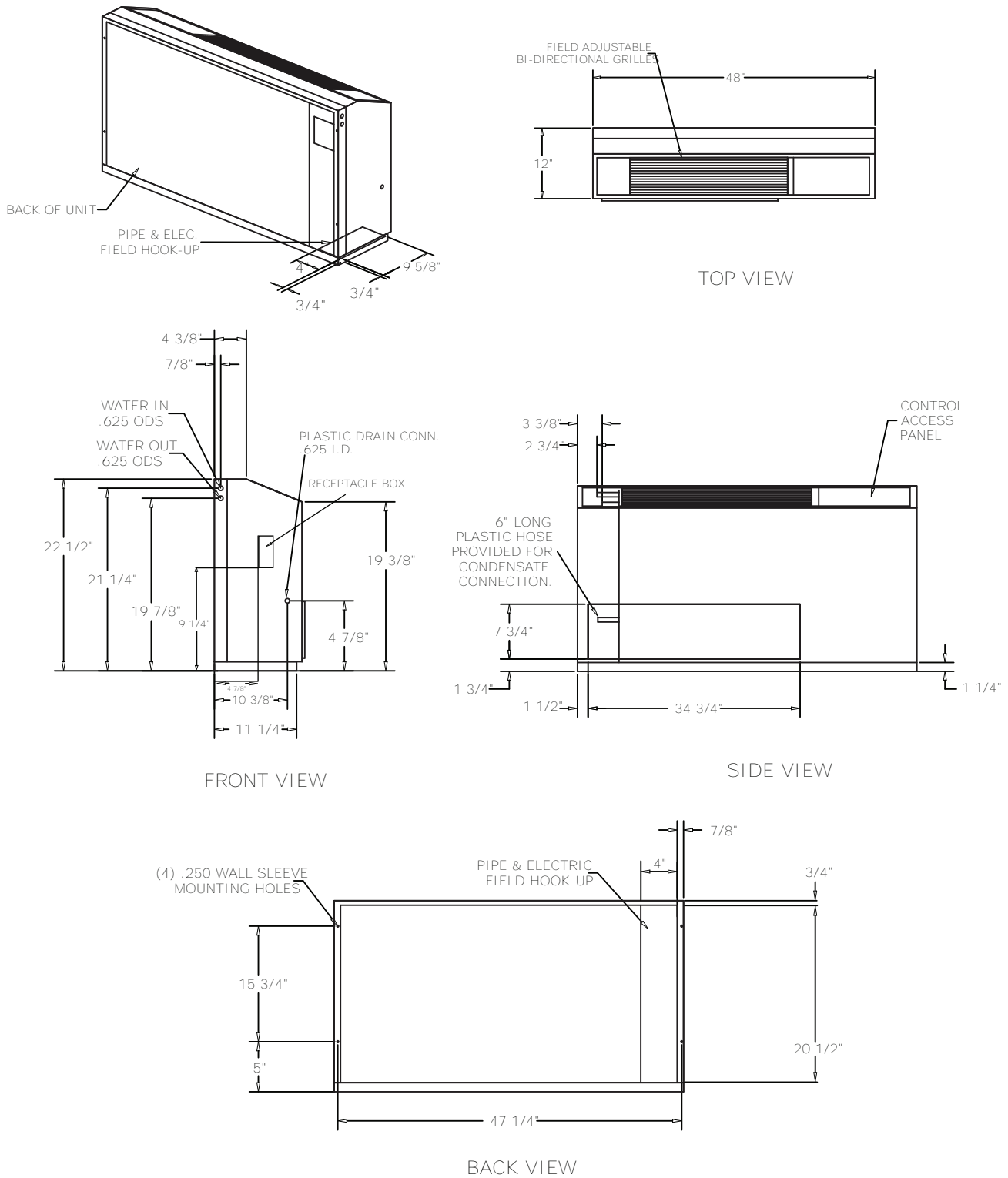

Figure 12. GEC 0.5 to 1.5 tons (60 Hz) - cabinet (LH) low height unit





Unit Dimensions

Figure 13. GEC 0.5 to 1.5 tons (60 Hz) - chassis + low height factory configuration (RH)

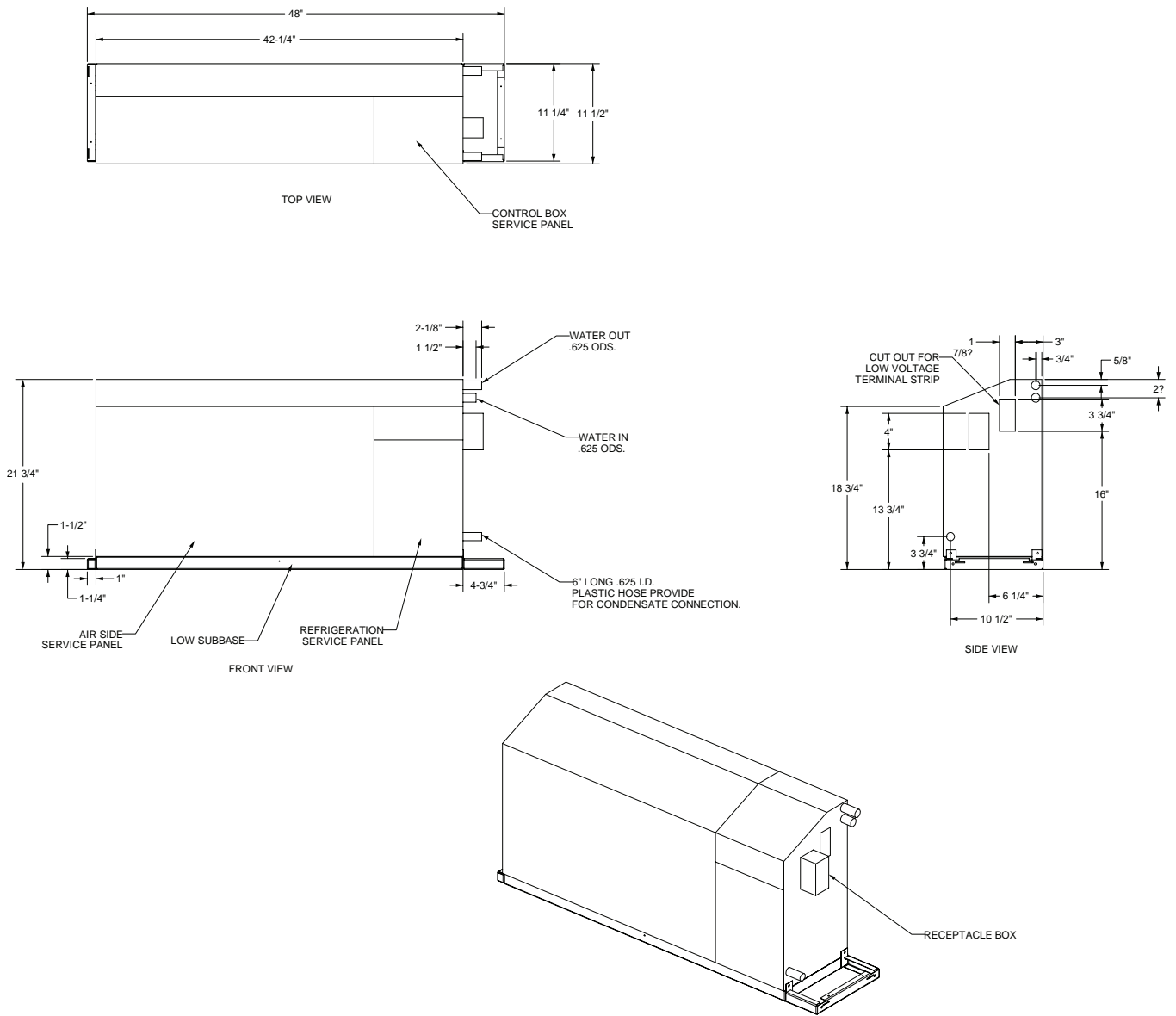
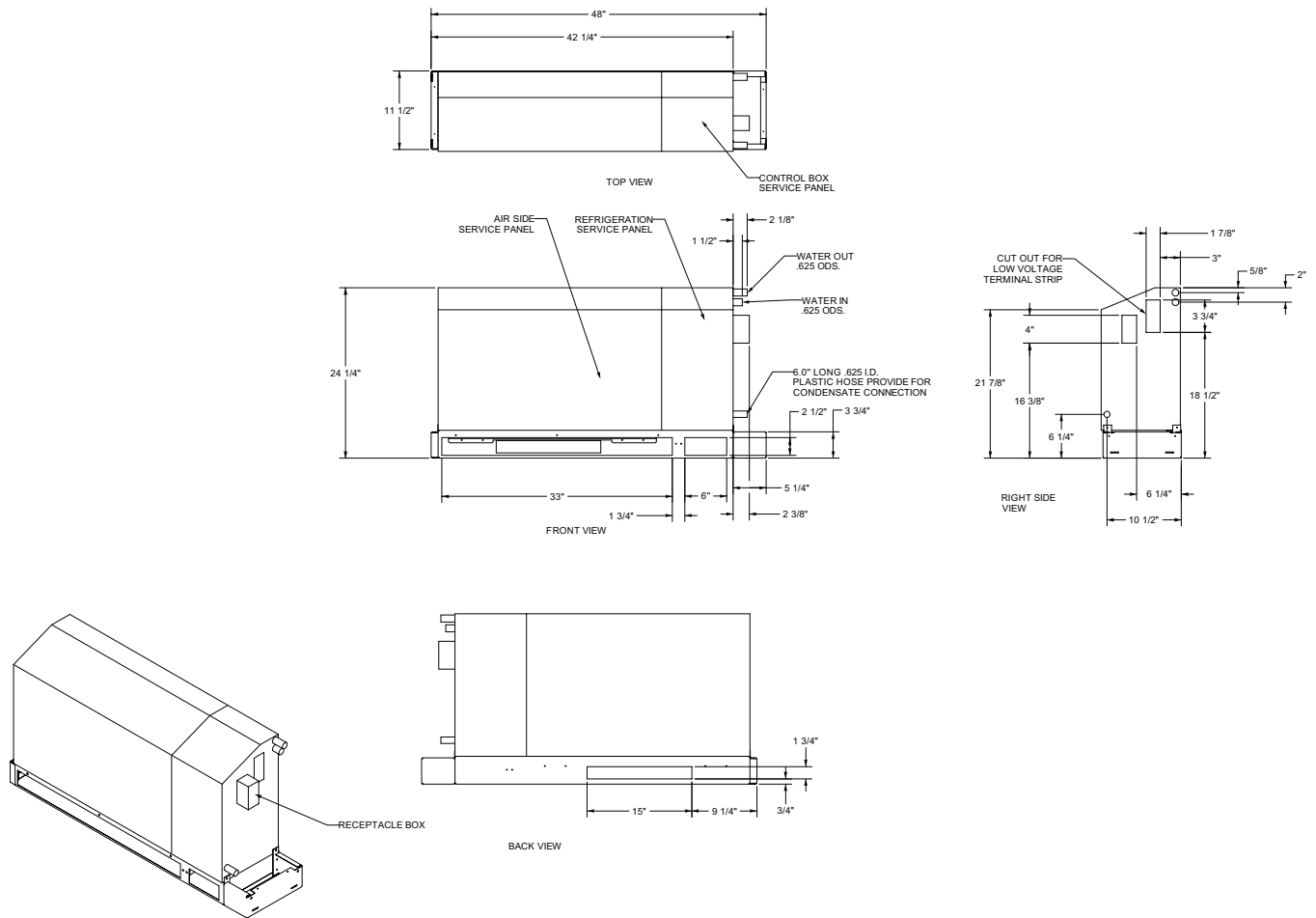

Figure 14. GEC 0.5 to 1.5 tons (60 Hz) - chassis + standard factory configuration (RH)





Unit Dimensions

Figure 15. GEC 0.5 to 1.5 tons (60 Hz) – chassis + low height factory configuration (LH)

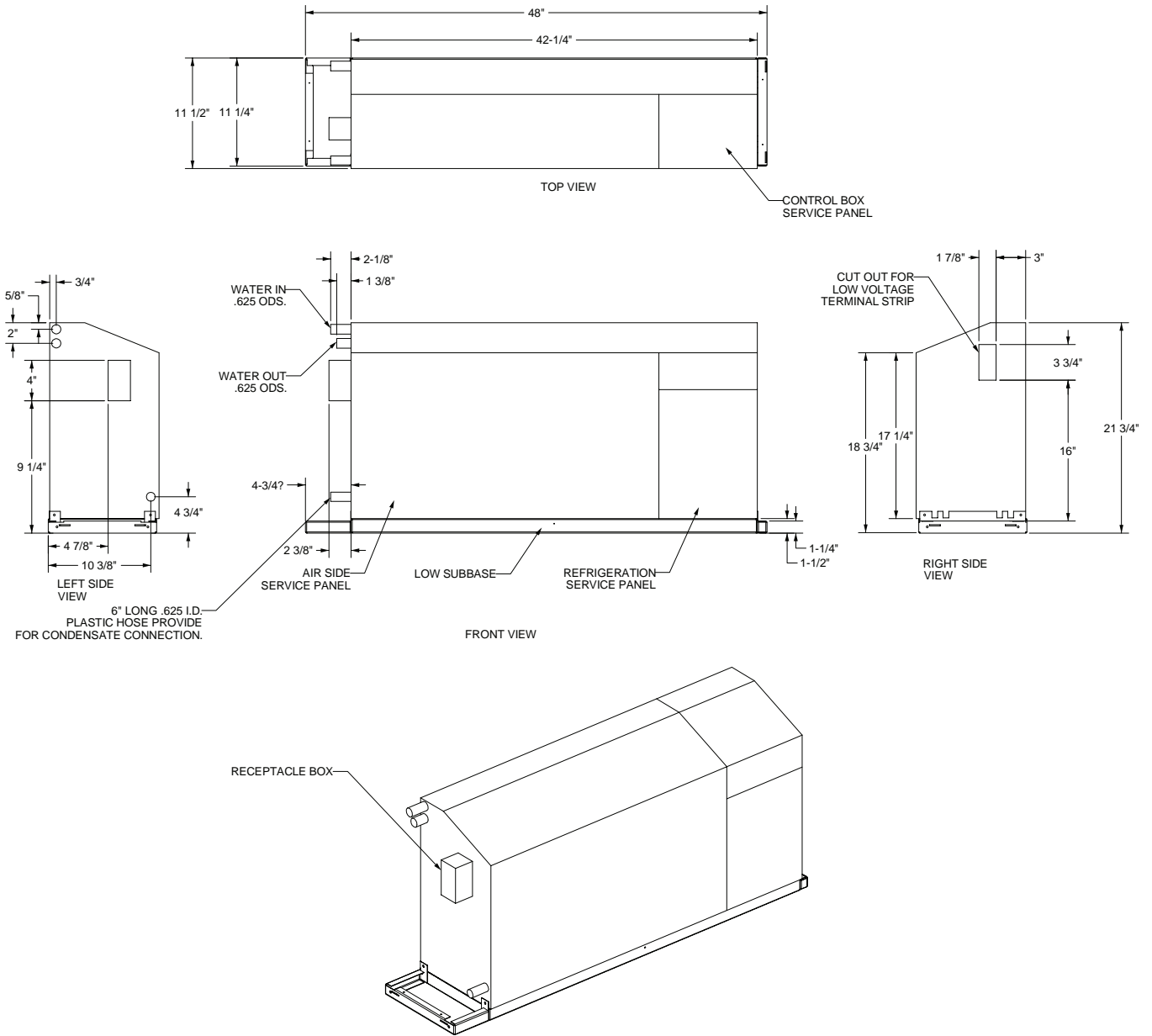
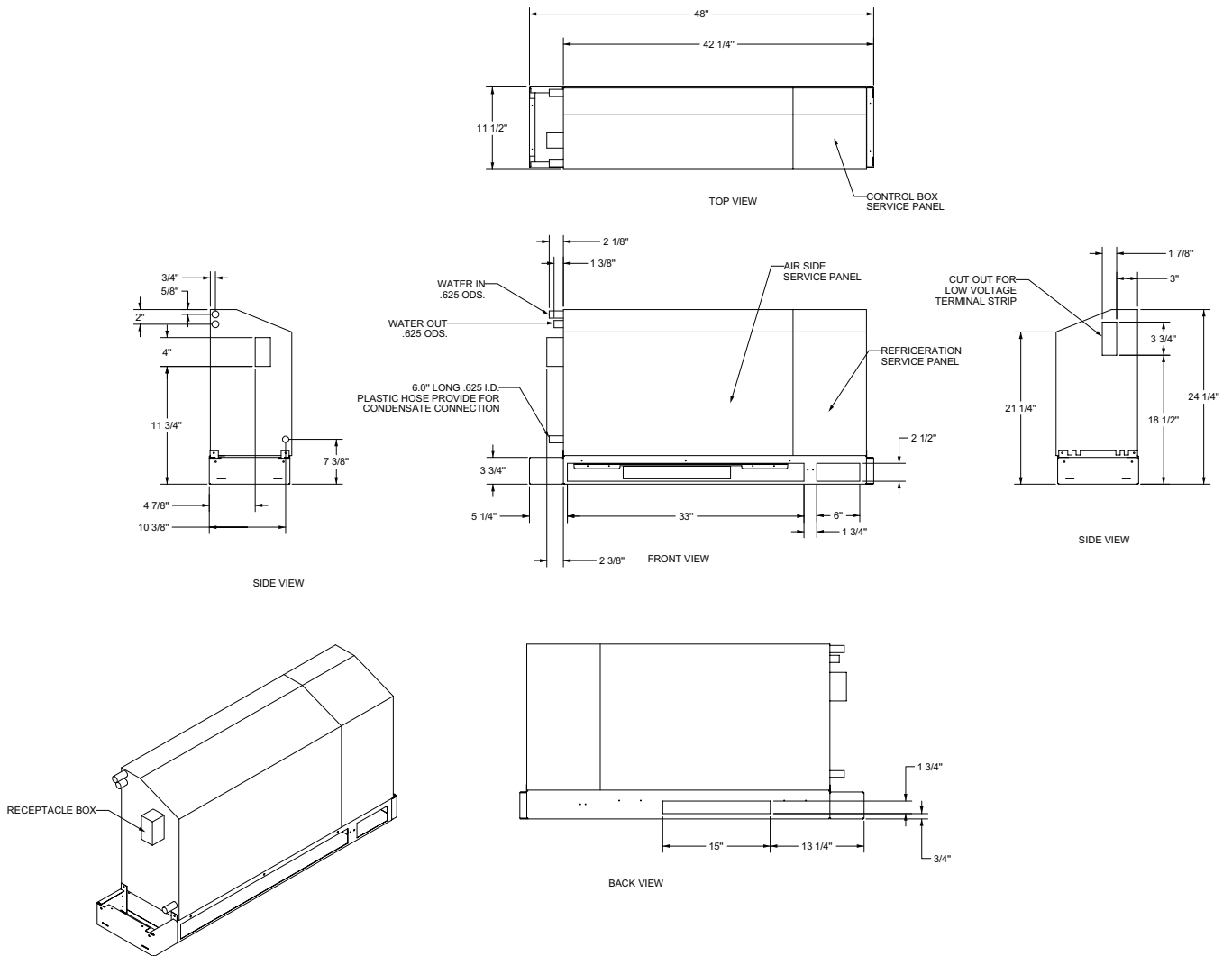

Figure 16. GEC 0.5 to 1.5 tons (60 Hz) – chassis + standard factory configuration (LH)





Weights

Table 2. Unit weights GEC (0.5 to 1.5 tons)

Unit Size	Shipping Weight with Pallet			Shipping Weight without Pallet		
	Unit Weight (lbs)	Chassis + low height subbase (lbs)	Chassis + standard subbase (lbs)	Unit Weight (lbs)	Chassis + low height subbase (lbs)	Chassis + standard subbase (lbs)
6	218	181	186	188	151	156
9	219	182	187	189	152	157
12	234	203	208	204	173	178
15	240	197	202	210	167	172
18	242	205	210	212	175	180



A2L Information

A2L Work Procedures

⚠ WARNING

Risk of Fire — Flammable Refrigerant!

Failure to follow instructions below could result in death or serious injury, and equipment damage.

- To be repaired only by trained service personnel.
- Do not puncture refrigerant tubing.
- Dispose of properly in accordance with federal or local regulations.

⚠ WARNING

Refrigerant under High Pressure!

Failure to follow instructions below could result in an explosion which could result in death or serious injury or equipment damage.

System contains refrigerant under high pressure. Recover refrigerant to relieve pressure before opening the system. See unit nameplate for refrigerant type. Do not use non-approved refrigerants, refrigerant substitutes, or refrigerant additives.

⚠ WARNING

Hazardous Voltage!

Failure to disconnect power before servicing could result in death or serious injury.

Disconnect all electric power, including remote disconnects before servicing. Follow proper lockout/tagout procedures to ensure the power can not be inadvertently energized. Verify that no power is present with a voltmeter.

The units described in this manual use R-454B refrigerant. Use ONLY R-454B rated service equipment or components with these units. For specific handling concerns with R-454B, contact your local Trane representative.

Installation, repair, removal, or disposal should be performed by trained service personnel.

At all times, Trane's maintenance and service guidelines shall be followed. If in doubt, contact Trane technical support for assistance.

Service

Prior to initiating work on equipment, check the area with an appropriate refrigerant detector. Ensure the service personnel are properly trained regarding work in potentially toxic or flammable atmospheres. Ensure that the leak detection equipment being used is suitable for use with all applicable refrigerants, i.e. non-sparking, adequately

sealed, or intrinsically safe. Be aware that the refrigerant does not contain an odor.

If any hot work is to be conducted on the refrigerating equipment or any associated parts, appropriate fire extinguishing equipment shall be available on hand. A dry powder or CO₂ fire extinguisher should be located adjacent to the charging area.

At all times, Trane's maintenance and service guidelines shall be followed. If in doubt, contact Trane technical support for assistance.

All maintenance staff and others working in the local area shall be instructed on the nature of the work being carried out. Work in confined spaces shall be avoided.

Ignition Source Mitigation

Do not use any sources of ignition when working on the refrigeration system.

Keep all ignition sources, including cigarette smoking, away from the site of installation, repair, removal or disposal, during which refrigerant can potentially be released to the surrounding space.

Survey the area around the equipment before initiating work to ensure no flammable hazards or ignition risks are present.

"No Smoking" signs shall be displayed.

Do not use devices that can be a source of ignition to accelerate defrosting of components. Use only defrost and cleaning procedures recommended by Trane. Do not pierce or burn.

Ventilation

Ensure that the area is in the open or that it is adequately ventilated before breaking into the system or conducting any hot work. A degree of ventilation shall continue during the period that the work is carried out. The ventilation should safely disperse any released refrigerant and preferably expel it externally into the atmosphere. If present, check that the ventilation system, including outlets, are operating adequately and are not obstructed.

Refrigerating Equipment

Refrigerant piping or components should not be installed in locations where substances which may corrode them are present.

Check that equipment hazard markings are visible and legible. Replace them if they are not.

For equipment using secondary fluids, like water or glycol, check that refrigerant is not present in the secondary fluid loop before conducting any hot work.

Electrical Devices

Do not apply power to the circuit if a fault exists which compromises safety. If the fault cannot be corrected immediately, but it is necessary to continue operation, an



A2L Information

adequate temporary solution shall be used. This shall be reported to the owner of the equipment, so all parties are advised.

Initial safety checks shall include:

- Cabling is not subject to wear, corrosion, excessive pressure, vibration, sharp edges, or any other adverse environmental effects. Account for the effects of aging or continual vibration from sources such as compressors or fans.
- Capacitors are discharged. This shall be done in a safe manner to avoid possibility of sparking.
- No live electrical components and wiring are exposed while charging, recovering, or purging the system.
- Verify continuity of earth bonding.
- Replace electrical components with Trane replacement parts, or those meeting the same ratings and qualified for flame arrest protection, UL LZGH2 category.

Leak Detection

Never use an open flame to detect leaks. A halide torch should not be used. Use only approved leak detection methods per this instruction manual.

The following leak detection methods are deemed acceptable for all refrigerant systems.

Electronic leak detectors may be used to detect refrigerant leaks but, in the case of flammable refrigerants, the sensitivity may not be adequate, or may need re-calibration. (Detection equipment shall be calibrated in a refrigerant-free area.) Ensure that the detector is not a potential source of ignition and is suitable for the refrigerant used. Leak detection equipment shall be set at a percentage of the LFL gas (25% maximum) is confirmed.

Leak detection fluids are also suitable for use with most refrigerants but the use of detergents containing chlorine shall be avoided as the chlorine may react with the refrigerant and corrode the copper pipe-work.

Examples of leak detection fluids are:

- Bubble method
- Fluorescent method agents

If a leak is suspected, all naked flames shall be removed/ extinguished.

If a refrigerant leak is found which requires brazing, all refrigerant shall be recovered from the system, or isolated (by means of shut off valves) in a part of the system remote from the leak.

Refrigerant Removal and Evacuation

Ensure that the correct number of cylinders for holding the total system charge is available. All cylinders to be used are designated for the recovered refrigerant and labeled for that refrigerant (special cylinders for the recovery of refrigerant, for example). Cylinders shall be complete with pressure-relief valve and associated shut-off valves in good

working order. Empty recovery cylinders are evacuated and, if possible, cooled before recovery occurs.

When breaking into the refrigerant circuit to make repairs – or for any other purpose – conventional procedures shall be used. However, for flammable refrigerants it is important that best practice be followed, since flammability is a consideration.

The following procedure shall be adhered to:

1. Safely remove refrigerant following local and national regulations.
2. Evacuate.
3. Purge the circuit with inert gas.
4. Evacuate (optional for A2L).
5. Continuously flush or purge with inert gas when using flame to open circuit.
6. Open the circuit.

Prior to refrigerant removal, open all appropriate valves, including solenoid and electronic expansion valves (EXVs). Use control settings, where available. When not available, manually open all electronically controlled valves using acceptable service procedures.

The recovery equipment shall be in good working order with instructions available. Equipment shall be suitable for the recovery of the flammable refrigerant. For specific handling concerns, contact the manufacturer. Ensure all hose connections are checked for tightness to avoid refrigerant leaks.

The refrigerant shall be recovered into the correct recovery cylinders if venting is not allowed by local and national codes. Do not mix refrigerants in recovery unit and especially not in cylinders.

Refrigerant recovery unit should be purged with an inert gas after each use or before using with a different refrigerant Class – for example, A2L to A1.

If compressors or compressor oils are to be removed, ensure that they have been evacuated to an acceptable level to make certain that flammable refrigerant does not remain within the lubricant. The compressor body shall not be heated by an open flame or other ignition sources to accelerate this process. When oil is drained from a system, it shall be carried out safely.

The system shall be purged with oxygen-free nitrogen to render the appliance safe for flammable refrigerants. This process might need to be repeated several times. Compressed air or oxygen shall not be used for purging refrigerant systems.

The system shall be vented down to atmospheric pressure to enable work to take place.

The outlet for the vacuum pump shall not be close to any potential ignition sources, and ventilation shall be available.

Refrigerant Charging

In addition to conventional charging procedures, the following requirements shall be followed.

- Ensure that contamination of different refrigerants does not occur when using charging equipment.
- Hoses or lines shall be as short as possible to minimize the amount of refrigerant contained in them.
- Cylinders shall be kept in an appropriate position according to the instructions.
- Ensure that the refrigerating system is earthed prior to charging the system with refrigerant.
- Label the system when charging is complete (if not already).
- Extreme care shall be taken not to overfill the refrigerating system.

Prior to recharging the system, it shall be pressure-tested with the appropriate purging gas. The system shall be leak-tested on completion of charging but prior to commissioning. A follow up leak test shall be carried out prior to leaving the site.

Prior to refrigerant charging, open all appropriate valves, including solenoid and electronic expansion valves (EXVs). Use control settings, where available. When not available, manually open all electronically controlled valves using acceptable service procedures.

Decommissioning

Before carrying out the decommissioning procedure, it is essential that the trained service personnel is completely familiar with the equipment and all its details. It is recommended good practice that all refrigerants are recovered safely. Prior to the task being carried out, an oil and refrigerant sample shall be taken in case analysis is required prior to re-use of recovered refrigerant. It is essential that electrical power is available before the task is commenced.

1. Become familiar with the equipment and its operation.
2. Isolate system electrically.
3. Before attempting the procedure, ensure that:
 - a. Mechanical handling equipment is available, if required, for handling refrigerant cylinders.
 - b. All personal protective equipment is available and being used correctly.
 - c. The recovery process is supervised at all times by a competent person.
 - d. Recovery equipment and cylinders conform to the appropriate standards.
4. Pump down refrigerant system, if possible.
5. If a vacuum is not possible, make a manifold so that refrigerant can be removed from various parts of the system.
6. Make sure that cylinder is situated on the scales before recovery takes place.
7. Start the recovery machine and operate in accordance with instructions.

8. Do not overfill cylinders (no more than 80% volume liquid charge).
9. Do not exceed the maximum working pressure of the cylinder, even temporarily.
10. When the cylinders have been filled correctly and the process completed, make sure that the cylinders and the equipment are removed from site promptly and all isolation valves on the equipment are closed off.
11. Recovered refrigerant shall not be charged into another refrigerating system unless it has been cleaned and checked.
12. When equipment has been decommissioned, attach a signed label which includes the date of decommissioning.

A2L Application Considerations

This product is listed to UL standard 60335-2-40, Household and Similar Electrical Appliances – Safety – Part 2-40: Particular Requirements for Electrical Heat Pumps, Air-Conditioners and Dehumidifiers, which defines safe design and use strategies for equipment using A2L refrigerants. This standard limits the refrigerant concentration in a space in the event of a refrigerant leak. To meet the requirements, the UL standard defines minimum room area, refrigerant charge limit, minimum circulation airflow and/or ventilation airflow requirements, and limits the use of ignition sources in spaces. The standard may require a unit refrigerant leak detection system.

For equipment with R-454B and charge amounts less than or equal to 3.91 lbs per circuit, this UL standard does not prescribe a room area limit and does not require a refrigerant leak detection system or any circulation airflow or ventilation airflow mitigation strategies. However, ignition sources in ductwork must be evaluated.

Depending on the application, a specific requirement of ANSI/ASHRAE Standard 15, Safety Standard for Refrigeration Systems, could be more stringent than UL 60335-2-40 requirements. See *Refrigeration Systems and Machinery Rooms Application Considerations for Compliance with ASHRAE® Standard 15-2022 Application Engineering Manual* (APP-APM001*-EN) for more information.

Ignition Sources in Ductwork

Do not install open flames in the ductwork. Hot surfaces exceeding 700°C (1290°F) should not be installed in the ductwork unless the average airflow velocity is not less than 1.0 m/s (200 ft/min) across the heater and proof of airflow is verified before system is energized.

Electric heaters can exceed the surface temperature limit if airflow distribution is poor, or insufficient airflow is provided over the heater.

Surface temperatures of most gas heaters do not exceed the surface temperature limits due to ANSI construction requirements.



A2L Information

Ignition Sources in Unit

This unit does not contain any ignition sources. All potential ignition sources, (including factory or field installed accessory electric heaters, gas heaters, relays, and contactors) were evaluated during product UL listing.

Minimum Room Area Limits (Refrigerant charge greater than 3.91 lb per circuit)

Equipment with R-454B charge amounts greater than 3.91 lb per circuit may require additional circulation or ventilation airflow mitigation strategies. In this case, two minimum room area (A_{min}) thresholds:

- The first threshold defines when equipment serving a single room is required to provide circulation airflow,

either continuous or activated by a leak detection system. A ducted system requires circulation airflow unless the smallest room it serves is larger than the adjusted A_{min} threshold. This product contains a leak detection system if a circuit charge is greater than 3.91 lbs. As a result, no further leak detection system evaluation is required.

- The second threshold defines when additional ventilation airflow is required. If the room area, A or TA, is below the adjusted A_{min} or TA_{min} threshold, additional ventilation is required to remove refrigerant in the event of a leak. Refer to UL 60335-2-40 Clause GG.8 and ANSIASHRAE Standard 15 Section 7 for natural and mechanical ventilation requirements.

Table 3. Minimum room area

Models	A_{min} (GG, 7DV)(m ²) 0.6 meters height	A_{min} (GG, 7DV) (ft ²) 1.94 feet height
GECK006	7	78
GECK009	7	78
GECK012	8	87
GECK015	9	95
GECK018	10	103

Minimum Room Area (A_{min}) Adjustments

Use equation below to adjust the minimum room area, as applicable, based on the unit's installation height, altitude, and occupancy level it serves.

$$A_{min,adj} = \text{Nameplate } A_{min} \times \text{Altitude Adj} \times \text{Height Adj} \times F_{occ}$$

Multiply the altitude adjustment factor in the table below by A_{min} listed on the unit nameplate or in the Installation, Operation, and Maintenance (IOM) manual.

Table 4. Altitude adjustment factor

Altitude (ft)	Sea Level to 2000	2001 to 4000	4001 to 6000	6001 to 8000	8001 to 10000	10001 to 12000	12001 to 14000	14001 to 15000	Over 15000
A_{min} Adjustment	1	1.05	1.11	1.17	1.24	1.32	1.41	1.51	1.57

In addition, A_{min} can be adjusted if the unit is installed in a room at a height that is higher than the minimum height shown on the unit. To adjust A_{min} , multiply by the ratio of the unit minimum release height (in meters) / actual release height (in meters). Use 0.6 m in the ratio for unit minimum installation heights less than or equal to 0.6 m.

For institutional occupancies, ASHRAE Standard 15 applies an additional adjustment factor F_{occ} to the amount of a charge allowed in a space. To calculate the adjusted A_{min} for institutional occupancies, multiply the A_{min} on the nameplate by two.

EXAMPLE 1: 20 Ton Packaged Rooftop Multi-Zone VAV System Serving an Institutional Occupancy Space

The packaged unit serves 7600 ft² of a nursing home located at an altitude of 4000 ft. The unit has two equally

charged 10 ton refrigeration circuits. Each circuit has 12 lbs of refrigerant with a minimum room area requirement of 180 ft² with a 2.2 m release height.

$$TA_{min,adj} = 180 \text{ ft}^2 \times 1.05 \times 2 = 378 \text{ ft}^2$$

No additional ventilation is required.

EXAMPLE 2: 10 Ton Split System Serving a Single Commercial Occupancy Space

The split system serves a 1500 ft² manufacturing space at 5000 ft altitude. The final installed charge of the single circuit 10 ton unit is 20 lb. The unit has an open return with a release height of 1 m and ducted supply air. The unit A_{min} is 660 ft².

$$A_{\text{min.adj}} = 660 \text{ ft}^2 \times 1.11 = 733 \text{ ft}^2$$

No additional ventilation is required.

Determining Room Area (A or TA)

The room area (A) is the room area enclosed by the projection to the floor of the walls, partitions, and doors of the space that the equipment serves. For ducted systems, total room area (TA) of all rooms connected by ducts, may be used instead of A.

Rooms connected by drop ceilings only are not considered a single room.

Rooms on the same floor of the building, and connected by an open passageway, can be considered part of the same room if the passageway is a permanent opening, extends to the floor and is intended for people to walk through.

Adjacent rooms on the same floor of the building and connected by permanent openings in the walls and/or doors between rooms (including gaps between the wall and the floor), can be considered part of the same room if the openings meet the following criteria.

- The opening is permanent and cannot be closed.
- Openings extending to the floor, such as door gaps, need to be at least 20 mm above the floor covering surface.
- Natural ventilations opening areas must meet the requirements of ANSI/ASHRAE Standard 15-2022, Section 7.2.3.2.

Rooms that are connected by a mechanical ventilation system can be considered a single room area if the

mechanical ventilation system meets the requirements of ANSI/ASHRAE Standard 15-2022, Section 7.6.4.

Leak Detection System (Refrigerant charge greater than 3.91 lb per circuit)

The leak detection system consists of one or more refrigerant detection sensors. When the system detects a leak, the following mitigation actions will be initiated until refrigerant has not been detected for at least 5 minutes:

- Energize the supply fan(s) to deliver a required minimum amount of circulation airflow.
- Disable compressor operation.
- Provide an output signal to fully open all zoning dampers, such as VAV boxes.
- Provide an output to energize additional mechanical ventilation (if needed).
- Units without airflow proving will disable electric heat sources.

Building fire and smoke systems may override this function.

If the refrigerant sensor has a fault, is at the end of its life, or is disconnected, the unit will initiate the mitigation actions. Mitigation actions may be verified by disconnecting the sensor.

The refrigerant sensors do not need service. Use only manufacturer-approved sensors when replacement is required.

Installation

⚠ WARNING

Hazardous Voltage!

Failure to disconnect power before servicing could result in death or serious injury.

Disconnect all electric power, including remote disconnects before servicing. Follow proper lockout/tagout procedures to ensure the power can not be inadvertently energized. Verify that no power is present with a voltmeter.

⚠ WARNING

Proper Field Wiring and Grounding Required!

Failure to follow code could result in death or serious injury.

All field wiring **MUST** be performed by qualified personnel. Improperly installed and grounded field wiring poses **FIRE** and **ELECTROCUTION** hazards. To avoid these hazards, you **MUST** follow requirements for field wiring installation and grounding as described in NEC and your local/state/national electrical codes.

1. Remove the unit and packaging from the crate. Inspect the unit. Carefully remove the stretch wrap and cardboard pieces. The installation literature and may be found on the back of the unit in a clear, plastic bag. Unit has been tied to skid by (2) shipping brackets.
2. Remove refrigeration panel and inspect the unit. Be certain the refrigerant tubing has clearance from adjacent parts. Verify that the electrical connections are tight and in-place.

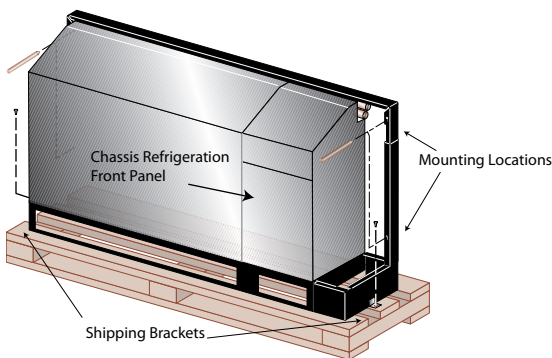

3. With the chassis still on the subbase, align the unit to the wall. If unit contains an outside air option, align the wall cutout to the subbase outside-air cut-out. Level the unit per plan requirements. Mark the four mounting locations for wall sleeve mounting to the wall. The dimensions should fall in line with Step 5.
4. Install the wall flange assembly to the desired wall with the use of four #10-field provided screws. The wall

flange assembly includes four, ¼ in. diameter clearance holes.

5. Mounting of the receptacle box (option) should be made prior to piping and electrical hook-up. This factory disconnect option is designed to fit inside the end pocket. Mount the receptacle box 2 in. above the top of the subbase with four, #8-field supplied screws.

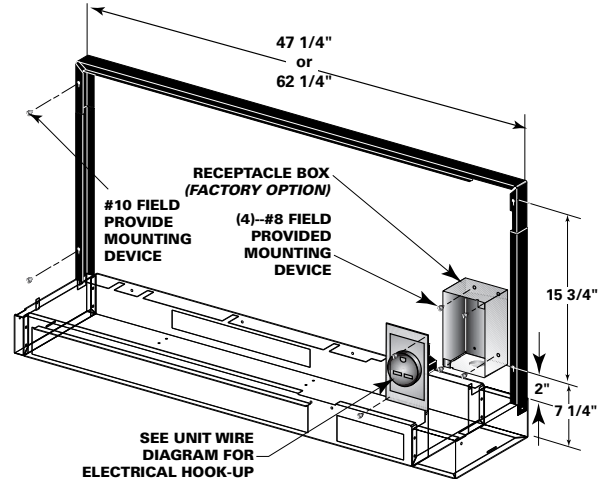

6. Mounting of the circuit breaker/receptacle box (option) should be made prior to piping and electrical hook-up. This factory disconnect option is designed to fit inside the end pocket. Mount the electrical box flush with the subbase with four, #8-field supplied screws.
7. Wiring of receptacle box (option). Power wiring to the equipment should be installed per national and local electric codes by a professional electrician. Power wiring to the receptacle box may be done at this time. See the unit's wiring schematic for field wiring.

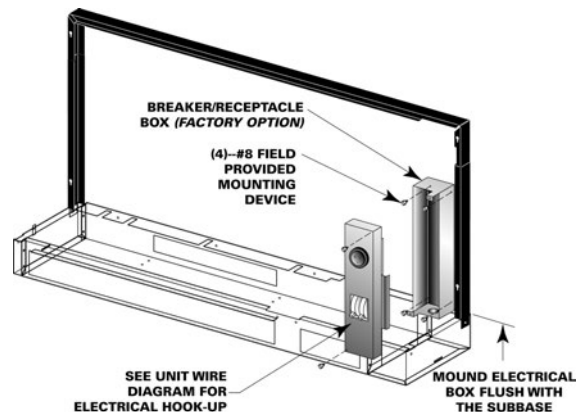

Note: Factory recommendation: Unit's receiving the circuit breaker option should have water and condensate piping supplied/returned through the bottom of the unit OR include the extended cabinet option.

8. Verify field installed receptacle box, condensate pipe, and supply/ return pipe are in the appropriate locations and does not require adjustments. Verify water connection angle prior to brazing of the unit water-in/out.
9. Install the field provided water connections to the unit water-in/out pipe. Trane recommends a 1/2 in. x 3/4 in. nominal ell to be field brazed to the factory 1/2 in. nominal water-in/out lines. Water in/out copper size: 5/8 in. ODS or 1/2 in. nominal.

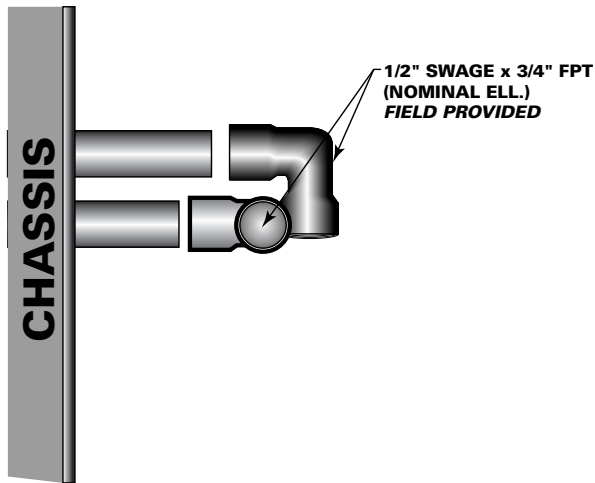

10. Inspect the system water pipe thoroughly before connecting the unit to the system. Water-to-refrigerant heat exchanger fouling, freezing and failure is imminent if the system pipe contains contaminants. Water to refrigerant heat exchanger ships with nitrogen holding charge. Remove rubber plugs from heat exchanger. All field piping must be cleaned of contaminants.
11. Connect the supply and return line to the unit inlet and outlet. Flexible hoses reduce vibration from the water lines to the unit. An isolation valve, p/t plugs and auto-flow valves are recommended to separate the closed/open loop from the mechanical device.
12. Because the console configuration is a blow-through design, no condensate trapping is necessary. However, it is necessary for the condensate to run in a downward motion to allow gravity to properly drain the system. The unit drain connection is 5/8 in. I.D. or 7/8 in. O.D. for all GEC* 006-018 systems.
13. Power wiring to the equipment should be installed per national and local electric codes by a professional electrician. Refer to Step 6, Step 7, and Step 8 for units that include the factory supplied receptacle box.

For units containing a field provided disconnect, or, are hard wired to the unit, Trane provides pig tail leads

inside a 2 x 4 handy-box in either the right or left side end pocket. See unit wiring schematic for details.

For units containing a wall mounted thermostat, a low voltage (18-pole) terminal strip is provided for field installation of the thermostat. See Step 18 for unit mounted controls.

14. The thermostat hook-up to the unit is made at the unit mounted 24V (18-pole) low voltage terminal strip. This strip is mounted on the exterior of the control box on the right side of the unit. For units that contain left hand piping, a low voltage crossover to the 18-pole terminal strip may be necessary. For this configuration, run the low voltage wires behind the chassis to the right side of the console unit for termination to the terminal strip.
15. Location of the thermostat or zone sensor is an important element of effective room control. Areas where the thermostat/zone sensor should not be mounted include: behind doors or corners; near hot or cold air ducts; near radiant heat (heat emitted from appliances or sun); near concealed pipes or chimneys; on outside walls or other non conditioned surfaces; in air-flows from adjacent zones or other units.

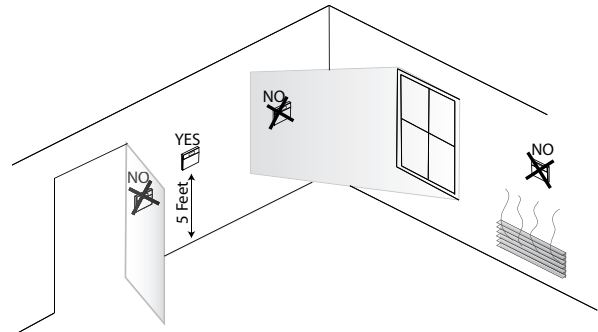

16. For units with unit mounted controls (option), all low voltage connections are factory made. The fan will run continuous with unit mounted controls.
17. For units with the factory provided receptacle box options, the receptacle plug may now be connected to the electrical outlet.





Electrical Data

Table 5. Electrical data (0.5 to 1.5 tons)

Model	Volts	Total Unit FLA	Comp RLA (ea)	CompL RA (ea)	No. of Comp	Cmp MCC	Blower Motor FLA	Blower Motor hp	Fan Motors	Minimum Circuit Ampacity	Maximum Overcurrent Protective Device	Electric Heat kW	Electric Heat Amps
GEC006	208/60/1	5.0	4.2	27.0	1	5.9	0.80	1/30	1	6.1	15	0.0	0.0
GEC006	208/60/1	11.7	4.2	27.0	1	5.9	0.80	1/30	1	14.4	15	2.25	10.82
GEC006	208/60/1	15.2	4.2	27.0	1	5.9	0.80	1/30	1	18.8	20	3.0	14.42
GEC006	230/60/1	4.9	4.2	27.0	1	5.9	0.70	1/30	1	6.0	15	0.0	0.0
GEC006	230/60/1	12.7	4.2	27.0	1	5.9	0.70	1/30	1	15.7	20	2.75	11.96
GEC006	265/60/1	3.5	2.8	22.0	1	3.9	0.70	1/20	1	4.2	15	0.0	0.0
GEC006	265/60/1	11.1	2.8	22.0	1	3.9	0.70	1/20	1	13.7	15	2.75	10.38
GEC009	208/60/1	5.0	4.2	27.0	1	5.9	0.80	1/30	1	6.1	15	0.0	0.0
GEC009	208/60/1	11.7	4.2	27.0	1	5.9	0.80	1/30	1	14.4	15	2.25	10.82
GEC009	208/60/1	15.3	4.2	27.0	1	5.9	0.80	1/30	1	18.9	20	3.0	14.42
GEC009	230/60/1	4.9	4.2	27.0	1	5.9	0.70	1/30	1	6.0	15	0.0	0.0
GEC009	230/60/1	12.7	4.2	27.0	1	5.9	0.70	1/30	1	15.7	20	2.75	11.96
GEC009	230/60/1	16.8	4.2	27.0	1	5.9	0.70	1/30	1	20.9	25	3.7	16.09
GEC009	265/60/1	3.5	2.8	22.0	1	3.9	0.70	1/30	1	4.2	15	0.0	0.0
GEC009	265/60/1	11	2.8	22.0	1	3.9	0.70	1/30	1	13.7	15	2.74	10.34
GEC009	265/60/1	14.7	2.8	22.0	1	3.9	0.70	1/30	1	18.2	20	3.7	13.96
GEC012	208/60/1	6.7	5.8	27.0	1	8.8	0.90	1/12	1	8.2	15	0.0	0.0
GEC012	208/60/1	11.8	5.8	27.0	1	8.8	0.90	1/12	1	14.5	15	2.25	10.82
GEC012	208/60/1	15.4	5.8	27.0	1	8.8	0.90	1/12	1	19.0	20	3.0	14.42
GEC012	230/60/1	7	5.8	27.0	1	8.8	0.70	1/12	1	8.0	15	0.0	0.0
GEC012	230/60/1	12.7	5.8	27.0	1	8.8	0.70	1/12	1	15.7	20	2.75	11.96
GEC012	230/60/1	16.8	5.8	27.0	1	8.8	0.70	1/12	1	20.9	25	3.7	16.09
GEC012	265/60/1	4.6	3.9	32.0	1	7.0	0.70	1/12	1	5.6	15	0.0	0.0
GEC012	265/60/1	11.1	3.9	32.0	1	7.0	0.70	1/12	1	13.7	15	2.74	10.34
GEC012	265/60/1	14.7	3.9	32.0	1	7.0	0.70	1/12	1	18.2	20	3.7	13.96
GEC015	208/60/1	12.8	11.8	33.0	1	16.5	1.00	1/12	1	15.8	25	0.0	0.0
GEC015	208/60/1	12.8	11.8	33.0	1	16.5	1.00	1/12	1	15.8	25	2.25	10.82
GEC015	208/60/1	15.5	11.8	33.0	1	16.5	1.00	1/12	1	19.1	25	3.0	14.42
GEC015	230/60/1	12.7	11.8	33.0	1	16.5	0.90	1/12	1	15.7	25	0.0	0.0
GEC015	230/60/1	12.9	11.8	33.0	1	16.5	0.90	1/12	1	15.9	25	2.76	12.0
GEC015	230/60/1	17	11.8	33.0	1	16.5	0.90	1/12	1	21.1	25	3.7	16.09
GEC015	265/60/1	6.8	6.1	37.0	1	8.6	0.70	1/12	1	8.4	15	0.0	0.0
GEC015	265/60/1	11	6.1	37.0	1	8.6	0.70	1/12	1	13.7	15	2.74	10.34
GEC015	265/60/1	14.7	6.1	37.0	1	8.6	0.70	1/12	1	18.2	20	3.7	13.96
GEC018	208/60/1	15.8	14.8	35.0	1	20.7	1.00	1/6	1	19.5	30	0.0	0.0
GEC018	208/60/1	15.8	14.8	35.0	1	20.7	1.00	1/6	1	19.5	30	2.25	10.82
GEC018	208/60/1	15.8	14.8	35.0	1	20.7	1.00	1/6	1	19.5	30	3.0	14.42
GEC018	230/60/1	15.7	14.8	35.0	1	20.7	0.90	1/6	1	19.4	30	0.0	0.0
GEC018	230/60/1	15.7	14.8	35.0	1	20.7	0.90	1/6	1	19.4	30	2.76	12.0
GEC018	230/60/1	17	14.8	35.0	1	20.7	0.90	1/6	1	21.1	30	3.7	16.09
GEC018	265/60/1	8.0	7.3	40.0	1	10.2	0.70	1/6	1	9.9	15	0.0	0.0
GEC018	265/60/1	11	7.3	40.0	1	10.2	0.70	1/6	1	13.7	15	2.74	10.34
GEC018	265/60/1	14.7	7.3	40.0	1	10.2	0.70	1/6	1	18.2	20	3.7	13.96

Table 6. Console VA

Designator	Controls	Deluxe with Reheat (75 VA)	Deluxe with Electric Heat (75 VA)	Symbio™ 400-B (75 VA)	x = ON ^(a)
	Controller	6.0	6.0	12.5	
1K1	Compressor Contactor	5.5	5.5	5.5	X
1K2	Fan Relay	9.5	9.5	9.5	
2L1	Reversing Valve	5.0	5.0	5.0	X
2L2	Reheat Valve	5.0	—	—	
5B3	Damper Actuator	—	—	—	
1K10	Electric Heat Contactor	—	5.5	Optional ^(b)	X
IU3	Boilerless Control Board	—	3.0	N/A	X
	Field Supplied Solenoid	7.0	7.0	7.0	X
1K6, 1K7	Reheat Relays(2)	12.5	—	Optional ^(c)	X
1K8	Reheat Low Speed Relay	—	—	N/A	X
1U1	Thermostat-Unit Mounted	6.0	6.0	N/A	X
	Timer Delay Relay	N/A	N/A	N/A	X
	Total VA	56.5	47.5	39.5	61.40
	Extra VA	18.5	27.5	32.5	13.60

Note: Listed VA values are for reference only. Actual values may vary with operating conditions.

- (a) Consider unit options and concurrent loads.
 (b) Electric heat is optional with Symbio™ 400-B controller. If electric heat is selected, add 5.5 VA.
 (c) HGR is optional with the Symbio™ 400-B controller. If HGR is selected, add 12.5 VA.



Pre-Start Checklist

Before energizing the unit, the following system devices must be checked:

- Is the high voltage power supply correct and in accordance with the nameplate ratings?
- Is the field wiring and circuit protection the correct size?
- Is the low voltage control circuit wiring correct per the unit wiring diagram?
- Is the piping system clean/complete and correct? (A recommendation of all system flushing of debris from the water-to-refrigerant heat exchanger, along with air purging from the water to-refrigerant heat exchanger be done in accordance with the Closed-Loop/Ground Source Heat Pump Systems Installation Guide).
- Is vibration isolation provided? (i.e. unit isolation pad, hose kits).
- Is unit serviceable? (Allow a 12-inch clearance at the unit front for serviceability).
- Are the low/high-side pressure temperature caps secure and in place?
- Are all the unit access panels secure and in place?
- Is the thermostat in the OFF position?
- Is the water flow established and circulating through all the units?
- Is the duct work correctly sized, run, taped, insulated and weather proofed with proper unit arrangement?
- Is the condensate line properly sized, run, and pitched?
- Is the zone sensor (when used) correctly wired and in a good location?
- Does the indoor blower turn freely without rubbing?
- Has all work been done in accordance with applicable local and national codes?
- Has heat transfer fluid been added in the proper mix to prevent freezing in closed system application?



Start-Up

Initial Unit Start-up

Note: Start-up for wall-mounted thermostats found in thermostat manufacturer literature.

Start-up with the conventional thermostat is included below:

1. Set the thermostat to the highest position.
2. Set the thermostat system switch to COOL with the fan control to AUTO. The compressor should NOT run.
3. Reduce the thermostat setting until the compressor, reversing valve and isolation valve (if used) are energized.

Adjust water flow utilizing pressure/temperature plugs and comparing to tables contained in specification sheet data. Water leaving the heat exchanger should be warmer than the entering water temperature (approximately 9-12°F); blower operation should be smooth; compressor and blower amps should be within data plate ratings; the suction line should be cool with no frost observed in the refrigerant circuit.

4. Check the cooling refrigerant pressures against values in .
5. Turn the thermostat system switch to the OFF position. Unit should stop running and the reversing valve should de-energize.
6. Leave unit off for approximately FIVE minutes to allow for pressure equalization.
7. Turn the thermostat to the lowest setting.
8. Set the thermostat system switch to the HEAT position.
9. Adjust the temperature setting upward until the unit is energized. Warm air should blow from the register. A water temperature decrease of approximately 5-9°F leaving the heat exchanger should be noted. The blower and compressor operation should be smooth with no frost observed in the refrigeration circuit.
10. Check the heating refrigerant pressures against values in .
11. Set the thermostat to maintain the desired space temperature.
12. Instruct the owner on system operation.

In order to minimize troubleshooting and costly system failures, complete the following checks and data entries before the system is put into full operation.

MODE	Heat	Cool
Entering fluid temperature		
Leaving fluid temperature		

MODE	Heat	Cool
Temperature differential		
Return-air temperature DB/WB		
Supply-air temperature DB/WB		
Temperature differential		
Water coil heat exchanger (Water Pressure IN)		
Water coil heat exchanger (Water Pressure OUT)		
Pressure Differential		
COMPRESSOR		
Amps		
Volts		
Discharge line temperature (after 10 minutes)		

Start-up Checklist and Log

Installing Contractor: Use this checklist to thoroughly checkout the system and units before and during start-up. (This form need not be returned to the factory unless requested during technical service support).

Job Number: _____

Model Number: _____

Date: _____

Serial Number: _____

In order to minimize troubleshooting and costly system failures, complete the following checks and data entries before the system is put into full operation.

Operating Pressures

There are many variables (airflow, air temperatures) in an air conditioning system that will affect operating refrigerant pressures and temperatures. The charts below shows approximate conditions and is based on air flow at the rated SCFM, entering air at 80.6°F(DB), 66.2°F(WB) in cooling, 68°F(DB) in heating. (+)Heating data with 35°F EWT is based on the use of an anti-freeze solution having a freezing point 20°F lower than the minimum expected entering temperature.



Start-Up

Table 7. Operating pressures in cooling/heating for GEC* units 60Hz

Model	Entering Water Temp (°F)	Water Flow (GPM)	Cooling				Heating			
			Suction Pressure, (psig)	Discharge Pressure, (psig)	Water Temp Rise (°F)	Air Temp Drop (°F DB)	Suction Pressure (psig)	Discharge Pressure (psig)	Water Temp Drop (°F)	Air Temp Rise (°F DB)
GEC*006	35°	1.4	—	—	—	—	71-87	228-279	6-8	16-20
GEC*006	35°	1.8	—	—	—	—	73-89	230-281	5-6	17-20
GEC*006	45°	1.4	112-137	168-205	14-17	23-28	82-100	238-291	7-9	20-25
GEC*006	45°	1.8	112-137	158-193	11-13	23-28	84-103	240-293	6-7	21-25
GEC*006	55°	1.4	114-139	197-241	14-17	23-28	97-118	250-306	9-11	23-28
GEC*006	55°	1.8	113-139	189-232	11-13	23-28	100-122	253-309	7-9	24-29
GEC*006	68°	1.4	118-144	231-282	13-16	22-27	112-137	263-322	10-13	27-33
GEC*006	68°	1.8	117-143	224-273	10-13	22-27	116-141	266-326	8-10	28-34
GEC*006	75°	1.4	125-152	259-317	14-17	22-27	124-152	273-334	11-14	29-36
GEC*006	75°	1.8	124-152	250-306	11-13	22-27	129-158	277-338	9-11	30-37
GEC*006	86°	1.4	127-156	298-364	13-16	21-26	146-179	289-354	13-16	32-40
GEC*006	86°	1.8	127-155	289-353	10-13	21-26	153-186	293-359	10-13	33-41
GEC*006	95°	1.4	130-158	331-404	13-15	21-25	—	—	—	—
GEC*006	95°	1.8	129-158	321-392	10-12	21-25	—	—	—	—
GEC*009	35°	1.7	—	—	—	—	72-89	227-278	5-7	16-19
GEC*009	35°	2.1	—	—	—	—	74-91	229-279	4-5	16-20
GEC*009	45°	1.7	113-138	160-195	12-14	23-28	83-102	237-290	6-8	20-24
GEC*009	45°	2.1	113-138	153-187	9-12	23-28	85-104	239-292	5-6	20-25
GEC*009	55°	1.7	114-140	191-234	12-14	22-27	100-122	250-305	7-9	23-28
GEC*009	55°	2.1	114-139	186-227	9-12	22-27	102-125	251-307	6-8	23-28
GEC*009	68°	1.7	118-144	225-275	11-14	21-26	115-140	262-320	9-11	26-32
GEC*009	68°	2.1	117-143	220-269	9-11	22-26	118-144	264-323	7-9	27-33
GEC*009	75°	1.7	125-153	252-308	11-14	22-27	128-156	272-332	10-12	29-35
GEC*009	75°	2.1	125-153	246-301	9-11	22-27	131-160	275-336	8-10	29-36
GEC*009	86°	1.7	128-156	291-355	11-13	21-26	151-184	288-352	11-14	32-39
GEC*009	86°	2.1	127-156	284-348	9-11	21-26	155-190	291-356	9-11	32-40
GEC*009	95°	1.7	130-159	323-395	10-13	20-25	—	—	—	—
GEC*009	95°	2.1	130-159	316-386	9-10	20-25	—	—	—	—
GEC*012	35°	2.2	—	—	—	—	72-88	242-295	6-7	16-20
GEC*012	35°	2.8	—	—	—	—	74-90	243-297	5-6	17-20
GEC*012	45°	2.2	115-140	173-211	13-16	23-28	86-105	256-313	7-8	19-24
GEC*012	45°	2.8	114-139	156-190	10-13	23-28	88-108	258-315	5-7	20-24
GEC*012	55°	2.2	117-143	192-234	13-16	22-27	102-125	269-329	8-10	22-27
GEC*012	55°	2.8	116-142	186-227	10-12	22-27	105-129	272-332	6-8	23-28
GEC*012	68°	2.2	120-147	225-275	12-15	22-26	121-148	286-350	9-11	25-31
GEC*012	68°	2.8	120-146	219-268	10-12	22-26	125-153	290-354	7-9	26-32
GEC*012	75°	2.2	122-149	247-302	12-15	21-26	134-164	297-363	10-12	27-33
GEC*012	75°	2.8	121-148	241-294	10-12	22-26	139-170	300-367	8-10	28-34

Table 7. Operating pressures in cooling/heating for GEC* units 60Hz (continued)

Model	Entering Water Temp (°F)	Water Flow (GPM)	Cooling				Heating			
			Suction Pressure, (psig)	Discharge Pressure, (psig)	Water Temp Rise (°F)	Air Temp Drop (°F DB)	Suction Pressure (psig)	Discharge Pressure (psig)	Water Temp Drop (°F)	Air Temp Rise (°F DB)
GEC*012	86°	2.2	124-152	282-345	11-14	21-25	157-192	313-383	12-14	30-37
GEC*012	86°	2.8	124-151	276-337	9-11	21-25	164-200	318-388	10-12	31-38
GEC*012	95°	2.2	127-155	312-381	11-13	20-24	—	—	—	—
GEC*012	95°	2.8	126-154	305-373	9-10	20-25	—	—	—	—
GEC*015	35°	2.8	—	—	—	—	70-86	252-308	7-8	21-25
GEC*015	35°	3.5	—	—	—	—	72-88	254-311	5-7	21-26
GEC*015	45°	2.8	108-132	162-198	13-16	24-29	84-102	267-327	8-9	25-30
GEC*015	45°	3.5	108-132	155-190	10-12	24-29	86-105	270-330	6-8	25-31
GEC*015	55°	2.8	109-133	194-237	13-16	24-29	99-121	283-345	9-11	28-34
GEC*015	55°	3.5	109-133	186-228	10-12	24-29	102-125	286-349	7-9	29-35
GEC*015	68°	2.8	111-136	244-299	13-16	23-28	118-144	305-373	10-13	32-39
GEC*015	68°	3.5	111-136	238-291	10-12	23-28	122-149	309-377	9-10	33-40
GEC*015	75°	2.8	116-141	253-309	13-15	23-28	131-160	317-387	11-14	35-42
GEC*015	75°	3.5	115-141	247-302	10-12	23-29	136-166	321-392	9-11	36-44
GEC*015	86°	2.8	118-145	293-358	12-15	23-28	154-188	336-411	13-16	38-47
GEC*015	86°	3.5	118-145	285-348	10-12	23-28	160-196	341-417	11-13	39-48
GEC*015	95°	2.8	121-147	325-397	12-15	22-27	—	—	—	—
GEC*015	95°	3.5	120-147	318-389	10-12	22-27	—	—	—	—
GEC*018	35°	3.4	—	—	—	—	70-86	260-318	6-8	22-27
GEC*018	35°	4.2	—	—	—	—	72-87	262-320	5-6	22-27
GEC*018	45°	3.4	103-126	163-200	12-15	25-31	81-100	272-333	7-9	26-31
GEC*018	45°	4.2	103-126	157-192	10-12	25-31	84-102	274-335	6-7	26-32
GEC*018	55°	3.4	105-128	195-239	12-15	24-30	97-119	288-352	8-10	29-36
GEC*018	55°	4.2	105-128	188-230	10-12	25-30	100-122	291-356	7-8	30-36
GEC*018	68°	3.4	108-132	240-293	12-15	24-29	116-142	309-377	9-11	33-40
GEC*018	68°	4.2	107-131	234-286	10-12	24-29	120-146	312-382	8-10	34-41
GEC*018	75°	3.4	113-138	255-312	12-15	24-29	129-158	322-393	10-13	36-43
GEC*018	75°	4.2	112-137	249-305	10-12	24-29	133-163	325-398	9-10	36-44
GEC*018	86°	3.4	116-142	293-359	12-15	23-28	152-186	342-418	12-14	39-48
GEC*018	86°	4.2	116-142	287-351	10-12	23-28	158-193	346-423	10-12	40-49
GEC*018	95°	3.4	118-145	326-398	12-14	23-28	—	—	—	—
GEC*018	95°	4.2	118-144	319-390	10-12	23-28	—	—	—	—

Water Pressure Drop

See Table 8, p. 36 and Table 9, p. 36 to define feet of head/pressure drop.

Notes:

- The feet of pressure (ft/ head) provided is at AHRI/ISO standard.
- To calculate feet of head, when using gauges that read in PSIG, multiply PSI by 2.31.



Start-Up

Table 8. Cooling water pressure drops (WPD) in feet of head for GEC* units - 0.5 to 1.5 tons

Unit Size (60 Hz)	EWT °F	GPM	Ft. Pressure
006	86	1.8	3.4
009	86	2.1	4.4
012	86	2.8	9.4
015	86	3.5	14.0
018	86	4.2	11.7

Table 9. Heating water pressure drops (WPD) in feet of head for GEC* units - 0.5 to 1.5 tons

Unit Size (60 Hz)	EWT °F	GPM	Ft. Pressure
006	68	1.8	3.6
009	68	2.1	4.7
012	68	2.8	10.0
015	68	3.5	14.8
018	68	4.2	12.4

Water Volume

See [Table 10, p. 36](#) to calculate glycol requirements for the unit.

Table 10. Water volume for GEC* units

Unit Size (60 Hz)	Water Side Volume (in ³)	Water Side Volume (ft ³)	Water Side Volume (gallons)
006-009	13.6	0.008	0.059
012-015	23.1	0.013	0.100
018	36	0.021	0.156



Maintenance

⚠ WARNING

Hazardous Service Procedures!

Failure to follow all precautions in this manual and on the tags, stickers, and labels could result in death or serious injury.

Technicians, in order to protect themselves from potential electrical, mechanical, and chemical hazards, **MUST** follow precautions in this manual and on the tags, stickers, and labels, as well as the following instructions: Unless specified otherwise, disconnect all electrical power including remote disconnect and discharge all energy storing devices such as capacitors before servicing. Follow proper lockout/tagout procedures to ensure the power can not be inadvertently energized. When necessary to work with live electrical components, have a qualified licensed electrician or other individual who has been trained in handling live electrical components perform these tasks.

Preventive Maintenance

Filter maintenance must be performed for proper operation of the equipment. Filters should be inspected at least every three months, and replaced when dirty. Filter sizing is shown in [Table 11, p. 37](#):

Table 11. Filter sizing

Unit Size (60) Hz	Filter Size (Nominal) inches
006-018	10 x 10, 10 x 30 (std height unit)
006-018	7 ¾ x 30 5/8 (low height unit)

Check the contactors and relays within the control panel at least once a year. It is good practice to check the tightness of the various wiring connections within the control panel.

A strainer (60 mesh or greater) must be used on an open loop system to keep debris from entering the unit heat exchanger and to have a clean system.

For units on well water, it is important to check the cleanliness of the water-to-refrigerant heat exchanger. If contaminated with dirt and scaling as a result of bad water, the heat exchanger will have to be back flushed and cleaned with a chemical that will remove the scale. This service should be performed by an experienced service person.

Water quality should be checked periodically. See [Table 12, p. 37](#).

Table 12. Water quality

Scaling	Amount
Calcium and magnesium (total hardness)	Less than 350 ppm
Corrosion	
pH	7-9.5
Hydrogen Sulfide	Less than 1 ppm
Sulfates	Less than 25 ppm
Chlorides	Less than 125 ppm
Carbon Dioxide	Less than 75 ppm
Total dissolved solids (TDS)	Less than 1000 ppm
Biological Growth	
Iron Bacteria	Low
Erosion	
Suspended Solids	Low

Filter Replacement (Standard Height Configuration)

Filter replacement is done at the front return-air opening of the console unit. The maintenance process is done through the following process:

1. Through the return-air opening, insert a screwdriver and depress the screws on the subbase.
2. Remove two filter brackets and slide filter to the back of the console unit.
3. Allow the front edge of the filter to drop to floor level.
4. Pull the filter out of the front opening.

Note: REVERSE the cycle to install a new filter.

Filter Replacement (Low Height Configuration)

Filter replacement is done at the front return-air opening of the console unit. A slotted screwdriver is needed for the replacement. The maintenance process is done through the following process.

1. Insert screwdriver and depress grill tab (2-per grille).
2. Rotate grille down, and lift grille upward to remove grille. The removal of one grille is required.
3. Slide the filter through the grille hole in the cabinet front.

Note: REVERSE the process to install a new filter.



Troubleshooting

⚠ WARNING

Hazardous Service Procedures!

Failure to follow all precautions in this manual and on the tags, stickers, and labels could result in death or serious injury.

Technicians, in order to protect themselves from potential electrical, mechanical, and chemical hazards, **MUST** follow precautions in this manual and on the tags, stickers, and labels, as well as the following instructions: Unless specified otherwise, disconnect all electrical power including remote disconnect and discharge all energy storing devices such as capacitors before servicing. Follow proper lockout/tagout procedures to ensure the power can not be inadvertently energized. When necessary to work with live electrical components, have a qualified licensed electrician or other individual who has been trained in handling live electrical components perform these tasks.

Deluxe 24V Controls

Troubleshooting units which contain the deluxe 24V control option may be made easy by using the three LEDs (light emitting diodes). These LEDs are provided for indicating the operating mode of the controller. The LEDs are intended to aid in troubleshooting. The LEDs are labeled on the circuit board with numbers as referenced in [Table 13, p. 38](#).

Table 13. Diagnostic LEDs

Color: Green	Color: Red		Controller Mode
LED1	LED2	LED3	
OFF	OFF	OFF	Control OFF
ON	OFF	OFF	Normal/Compressor OFF
ON	OFF	FLASH	Anti-short cycle
ON	OFF	ON	Normal/Compressor ON
FLASH	ON	OFF	Brownout Condition
ON	FLASH	ON	Soft Lockout (low pressure)
ON	FLASH	FLASH	Soft Lockout (high pressure)
ON	ON	ON	Manual Lockout (low pressure)
ON	ON	FLASH	Manual Lockout (high pressure)
ON	FLASH	OFF	Manual Lockout (condensate overflow)
ON	ON	OFF	Compressor Disable

Table 14. Troubleshooting table

Problem	Heating	Cooling	Cause	Correction
No response to any thermostat setting	X	X	Main power off	Check fuses
	X	X	Defective control transformer	Replace
	X	X	Broken or loose connection	Repair
	X	X	Defective thermostat	Replace
	X	X	Transformer	Reset Transformer
Unit short cycles	X	X	Thermostat or sensor improperly located	Relocate

Table 14. Troubleshooting table (continued)

Problem	Heating	Cooling	Cause	Correction
Blower runs, but compressor does not	X	X	Defective compressor overload	Replace (if external)
	X	X	Defective compressor contactor	Replace
	X	X	Supply Voltage too low	Correct
	X	X	Defective compressor capacitor	Replace
	X	X	Defective windings	Replace
	X	X	Limit switches open	Check cause/Replace or repair
Problem	Heating	Cooling	Cause	Correction
Insufficient capacity	X	X	Dirty filter	Replace/clean
	X	X	Blower RPM too low	Correct
	X	X	Loss of conditioned air due to leaks in ductwork	Repair leaks
		X	Introduction of excessively hot return-air	Correct
	X		Introduction of excessively cold return-air	Correct
	X	X	Low on refrigerant charge	Locate leak, repair and recharge by weight (not by superheat)
	X	X	Restricted thermal expansion valve	Replace
	X	X	Defective reversing valve	See WSHP-IOM-# for touch test chart
	X	X	Thermostat improperly located	Relocate
	X	X	Unit undersized	Recalculate heat gains/losses
	X	X	Inadequate water flow	Increase GPM
	X	X	Scaling in heat exchanger	Clean or replace
		X	Water too hot	Decrease temperature
	X		Water too cold	Increase temperature
	X	X	Filter drier blocked	Replace
	X	X	Defective reversing valve	Check or replace
High pressure switch open		X	Inadequate GPM	Increase water flow to unit
		X	Water too hot	Decrease temperature
	X		Inadequate air flow	Check, clean blower and coil
	X		Dirty filter	Clean/replace
	X	X	Overcharged with refrigerant	Decrease charge
	X	X	Defective pressure switch	Check or replace

Troubleshooting

Table 14. Troubleshooting table (continued)

Problem	Heating	Cooling	Cause	Correction
High head pressure		X	Trash in heat exchanger	Backflush
		X	Low water flow	Increase GPM
	X	X	Overcharge of refrigerant	Decrease charge
	X	X	Non-condensable in system	Evacuate and recharge by weight
	X	X	Water too hot	Decrease temperature
	X		Dirty filter	Clean / replace
	X		Inadequate air flow	Check, clean blower and coil
Low suction pressure	X	X	Undercharged	Locate leak, repair and recharge
	X	X	Restricted thermal expansion valve	Repair / replace
		X	Inadequate air flow	Check, clean blower and coil
		X	Dirty filter	Clean/replace
	X		Inadequate GPM	Increase GPM
Low pressure switch open	X		Inadequate GPM	Increase GPM
	X		Water too cold	Increase temperature
		X	Inadequate air flow	Increase CFM
		X	Dirty filter	Clean/replace
	X	X	Undercharged with refrigerant	Increase charge
	X	X	Defective pressure switch	Replace
	X	X	Heat transfer fluid too cold	Raise water temperature



Wiring Diagrams

Figure 17. Deluxe 24V controls

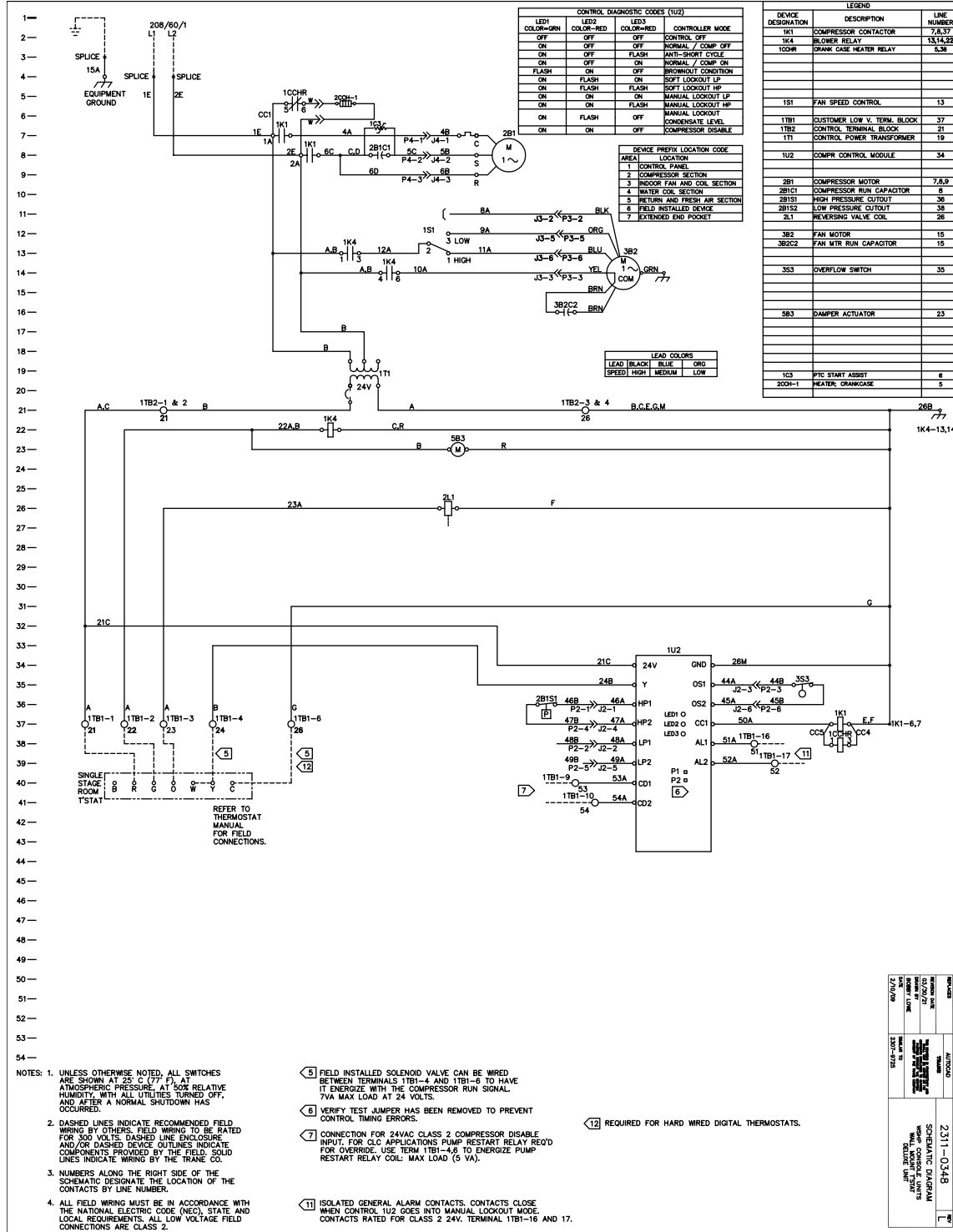

Figure 18. Symbio™ 400-B - 208V-60 Hz - 1pH

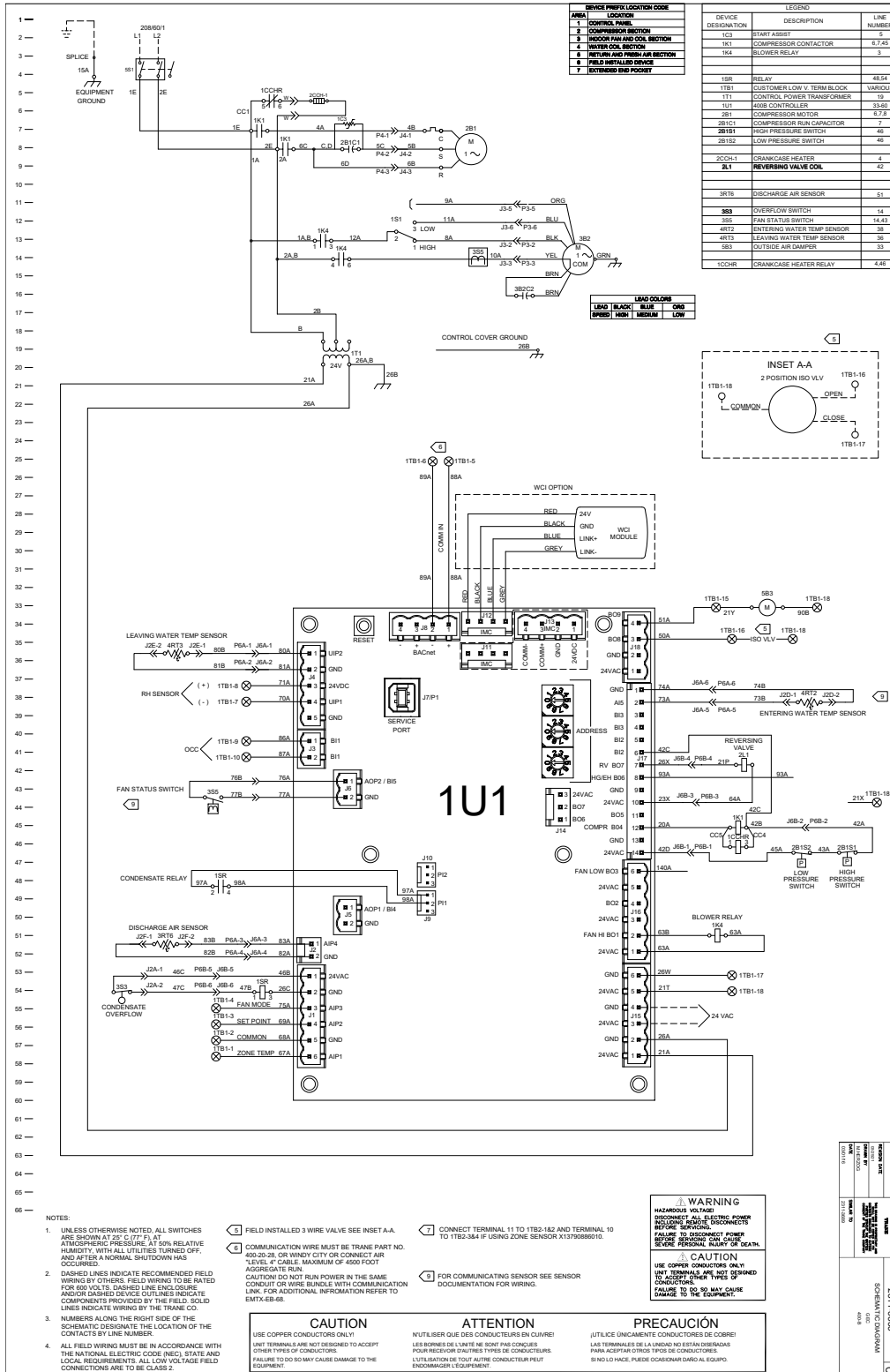
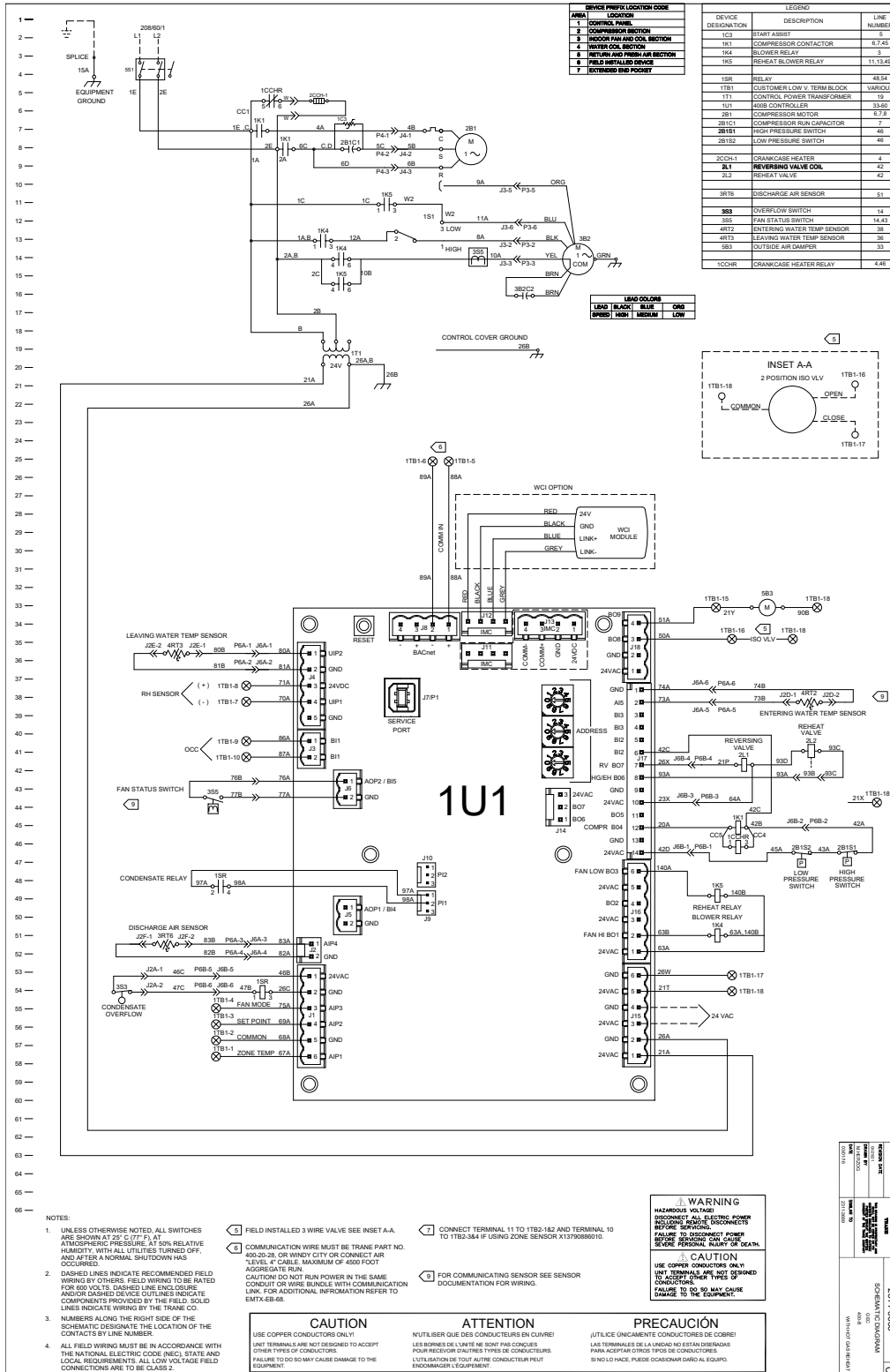

Figure 19. Symbio 400-B - 208V-60 Hz - 1pH with hot gas reheat





Warranty

Standard Warranty

The standard water-source heat pump warranty is Trane's parts-only warranty, running 12-months from start-up, not to exceed 18-months from shipment. There is a standard 5-year compressor warranty.

Extended Warranty

The optional extended warranty is a second through fifth year warranty. The time starts at the end of standard 1-year coverage through the fifth year.

These extended warranties apply only to new equipment installed in domestic Trane sales territories and must be ordered prior to start-up.



Notes

Trane - by Trane Technologies (NYSE: TT), a global innovator - creates comfortable, energy efficient indoor environments for commercial and residential applications. For more information, please visit trane.com or tranetechnologies.com.

Trane has a policy of continuous product and product data improvements and reserves the right to change design and specifications without notice. We are committed to using environmentally conscious print practices.