



Installation, Operation, and Maintenance

Water Source Heat Pump

Axiom™ Rooftop

Standard Efficiency
3 to 25 Tons 60Hz



⚠ SAFETY WARNING

Only qualified personnel should install and service the equipment. The installation, starting up, and servicing of heating, ventilating, and air-conditioning equipment can be hazardous and requires specific knowledge and training. Improperly installed, adjusted or altered equipment by an unqualified person could result in death or serious injury. When working on the equipment, observe all precautions in the literature and on the tags, stickers, and labels that are attached to the equipment.

November 2024

WSHP-SVX021A-EN

TRANE
TECHNOLOGIES



Introduction

Read this manual thoroughly before operating or servicing this unit.

Warnings, Cautions, and Notices

Safety advisories appear throughout this manual as required. Your personal safety and the proper operation of this machine depend upon the strict observance of these precautions.

The three types of advisories are defined as follows:



Indicates a potentially hazardous situation which, if not avoided, could result in death or serious injury.



Indicates a potentially hazardous situation which, if not avoided, could result in minor or moderate injury. It could also be used to alert against unsafe practices.



Indicates a situation that could result in equipment or property-damage only accidents.

Important Environmental Concerns

Scientific research has shown that certain man-made chemicals can affect the earth's naturally occurring stratospheric ozone layer when released to the atmosphere. In particular, several of the identified chemicals that may affect the ozone layer are refrigerants that contain Chlorine, Fluorine and Carbon (CFCs) and those containing Hydrogen, Chlorine, Fluorine and Carbon (HCFCs). Not all refrigerants containing these compounds have the same potential impact to the environment. Trane advocates the responsible handling of all refrigerants.

Important Responsible Refrigerant Practices

Trane believes that responsible refrigerant practices are important to the environment, our customers, and the air conditioning industry. All technicians who handle refrigerants must be certified according to local rules. For the USA, the Federal Clean Air Act (Section 608) sets forth the requirements for handling, reclaiming, recovering and recycling of certain refrigerants and the equipment that is used in these service procedures. In addition, some states or municipalities may have additional requirements that must also be adhered to for responsible management of refrigerants. Know the applicable laws and follow them.

⚠ WARNING

Proper Field Wiring and Grounding Required!

Failure to follow code could result in death or serious injury.

All field wiring **MUST** be performed by qualified personnel. Improperly installed and grounded field wiring poses **FIRE** and **ELECTROCUTION** hazards. To avoid these hazards, you **MUST** follow requirements for field wiring installation and grounding as described in **NEC** and your local/state/national electrical codes.

⚠ WARNING

Personal Protective Equipment (PPE) Required!

Failure to wear proper PPE for the job being undertaken could result in death or serious injury.

Technicians, in order to protect themselves from potential electrical, mechanical, and chemical hazards, **MUST** follow precautions in this manual and on the tags, stickers, and labels, as well as the instructions below:

- Before installing/servicing this unit, technicians **MUST** put on all PPE required for the work being undertaken (Examples; cut resistant gloves/sleeves, butyl gloves, safety glasses, hard hat/bump cap, fall protection, electrical PPE and arc flash clothing). **ALWAYS** refer to appropriate Safety Data Sheets (SDS) and OSHA guidelines for proper PPE.
- When working with or around hazardous chemicals, **ALWAYS** refer to the appropriate SDS and OSHA/GHS (Global Harmonized System of Classification and Labelling of Chemicals) guidelines for information on allowable personal exposure levels, proper respiratory protection and handling instructions.
- If there is a risk of energized electrical contact, arc, or flash, technicians **MUST** put on all PPE in accordance with OSHA, NFPA 70E, or other country-specific requirements for arc flash protection, **PRIOR** to servicing the unit. **NEVER** PERFORM ANY SWITCHING, DISCONNECTING, OR VOLTAGE TESTING WITHOUT PROPER ELECTRICAL PPE AND ARC FLASH CLOTHING. ENSURE ELECTRICAL METERS AND EQUIPMENT ARE PROPERLY RATED FOR INTENDED VOLTAGE.

⚠ WARNING**Follow EHS Policies!**

Failure to follow instructions below could result in death or serious injury.

- All Trane personnel must follow the company's Environmental, Health and Safety (EHS) policies when performing work such as hot work, electrical, fall protection, lockout/tagout, refrigerant handling, etc. Where local regulations are more stringent than these policies, those regulations supersede these policies.
- Non-Trane personnel should always follow local regulations.

⚠ WARNING**R-454B Flammable A2L Refrigerant!**

Failure to use proper equipment or components as described below could result in equipment failure, and possibly fire, which could result in death, serious injury, or equipment damage.

The equipment described in this manual uses R-454B refrigerant which is flammable (A2L). Use ONLY R-454B rated service equipment and components. For specific handling concerns with R-454B, contact your local representative.

⚠ WARNING**Electrical Shock Hazard!**

Failure to follow instructions below could result in death or serious injury.

Properly connect the system's oversized protective earthing (grounding) terminal(s).

Copyright

This document and the information in it are the property of Trane, and may not be used or reproduced in whole or in part without written permission. Trane reserves the right to revise this publication at any time, and to make changes to its content without obligation to notify any person of such revision or change.

Trademarks

All trademarks referenced in this document are the trademarks of their respective owners.

Product Safety Information

This appliance is not intended for use by persons (including children) with reduced physical, sensory or mental capabilities, or lack of experience and knowledge, unless they have been given supervision or instruction concerning use of the appliance by a person responsible for their safety. Children should be supervised to ensure that they do not play with the appliance.

Maximum altitude of use 3000 meters.

This appliance incorporates an earth connection for functional purposes only.



Table of Contents

| | | | |
|---|----|--|----|
| Model Number Description | 6 | Digital Display Zone Sensor (BAYSENS135*) | 10 |
| General Information | 8 | Touch Screen Programmable Zone Sensor (BAYSENS800) | 11 |
| Unit Inspection | 8 | Evaporator Frost Control | 11 |
| Exterior Inspection | 8 | Discharge Line Temp Switch (DLTS) | 11 |
| Inspection for Concealed Damage | 8 | Smoke Detector Sensor (Optional) | 11 |
| Unit Storage | 8 | Phase Monitor | 11 |
| Unit Description | 8 | Operating Limits | 12 |
| Door Handles | 8 | Pre-Installation | 13 |
| Unit Nameplate | 8 | Precautionary Measures | 13 |
| Compressor Nameplate | 8 | First Aid Measures | 13 |
| LonTalk Communication Interface (Optional) | 9 | A2L Information | 14 |
| BACnet Communications Interface (Optional) | 9 | A2L Work Procedures | 14 |
| System Input Devices and Functions | 9 | Servicing | 14 |
| Supply Fan Failure | 9 | Leak Detection | 15 |
| Clogged Filter Switch (Optional) | 9 | Refrigerant Removal and Evacuation | 15 |
| Condensate Drain Pan Overflow Switch | 9 | Refrigerant Charging | 15 |
| Compressor Disable (CPR1/2) | 9 | Decommissioning | 16 |
| Low Pressure Control | 9 | A2L Application Considerations | 16 |
| High Pressure Control | 10 | Ignition Sources in Ductwork | 16 |
| Zone Sensors | 10 | Ignition Sources in Unit | 17 |
| Manual Changeover (BAYSENS107*) | 10 | Minimum Room Area Limits (Refrigerant charge greater than 3.91 lb per circuit) | 17 |
| Manual/Automatic Changeover (BAYSENS109*) | 10 | Leak Detection System (Refrigerant charge greater than 3.91 lb per circuit) | 18 |
| Wall Mounted Relative Humidity Sensor (BAYSENS036*) | 10 | Dimensions and Weights | 19 |
| Duct Mounted Relative Humidity Sensor (BAYSENS037*) | 10 | Cabinet Size | 19 |
| Integrated Comfort System (BAYSENS073*) | 10 | Dimensional Data | 19 |
| Integrated Comfort System (BAYSENS074*) | 10 | Clearances | 35 |
| Remote Zone Sensor (BAYSENS016*) | 10 | Weights | 36 |
| Remote Zone Sensor (BAYSENS077*) | 10 | Lifting and Rigging | 37 |
| Thermostat | 10 | Installation | 39 |
| High Temperature Sensor (FIAHTST001*) | 10 | Horizontal Units | 39 |
| | | Ductwork | 39 |
| | | Roof Curb | 44 |
| | | Downflow | 44 |

| | | | |
|--|----|--------------------------------------|----|
| Rigging | 45 | Symbio Controls | 54 |
| General Unit Requirements | 45 | Unit Start-Up | 56 |
| Factory Installed Economizer | 46 | Sequence of Operation | 56 |
| Return Air Smoke Detector | 46 | Return Air Smoke Detector | 56 |
| Air-Fi® Wireless Communication | | Compressor Start-Up | 56 |
| Interface | 47 | Hot Gas Reheat | 56 |
| Main Electrical Power Requirements | 47 | Final System Setup | 56 |
| Electric Heat Requirements | 47 | Maintenance | 58 |
| Low Voltage Wiring | 47 | Monthly Maintenance | 58 |
| Condensate Drain Configuration | 48 | Filters | 58 |
| Filter Installation | 48 | Return Air Smoke Detector | |
| Field Installed Power Wiring | 48 | Maintenance | 58 |
| Main Unit Power | 48 | Condensate Overflow Switch | 58 |
| Standard Wiring | 49 | Cooling Season | 58 |
| Optional TBUE Wiring (Through-the- | | Heating Season | 58 |
| Base Electrical Option) | 49 | Coil Cleaning | 59 |
| Field-Installed Control Wiring | 49 | Coil Cleaning Procedure | 59 |
| Control Power Transformer | 49 | Water Quality | 59 |
| Controls using 24 VAC | 49 | Annual Maintenance | 60 |
| Controls using DC Analog Input/ | | Final Process | 60 |
| Outputs (Standard Low Voltage Multi | | Troubleshooting | 61 |
| conductor Wire) | 50 | Wiring Diagrams | 62 |
| DC Conductors | 51 | Piping Diagrams | 64 |
| Space Temperature Averaging | 51 | Limited Warranty | 66 |
| Pre-Start | 53 | Electric Air Conditioner | 66 |
| Voltage Imbalance | 53 | GSK | 66 |
| Electrical Phasing (Three Phase | | | |
| Motors) | 53 | | |
| Compressor Crankcase Heaters | 54 | | |



Model Number Description

Digit 1 — Function

G = Rooftop WSHP

Digit 2 — Efficiency

S = Standard Efficiency

Digit 3 — Refrigerant

K = R-454B

Digit 4, 5, 6 — Nominal Gross Cooling Capacity (MBh)

036 = 3 Ton Unit

048 = 4 Ton Unit

060 = 5 Ton Unit

072 = 6 Ton Unit

090 = 7.5 Ton Unit

102 = 8.5 Ton Unit

120 = 10 Ton Unit

150 = 12.5 Ton Unit

180 = 15 Ton Unit

210 = 17.5 Ton Unit

240 = 20 Ton Unit

300 = 25 Ton Unit

Digit 7 — Design Sequence

A = Current Design

Digit 8 — Unit Voltage

3 = 208-230/60/3

4 = 460/60/3

W = 575/60/3

Digit 9 — Unit Controls

S = Symbio™ 700

Digit 10 — Heat Type

0 = Base Model

Digit 11 — Heating Capacity

0 = No Heat

B = 6kW Electric Heat

C = 9kW Electric Heat

E = 12kW Electric Heat

G = 18kW Electric Heat

K = 27kW Electric Heat

N = 36kW Electric Heat

P = 54kW Electric Heat

R = 72kW Electric Heat

Digit 12, 13 — Service Digits

00 = Service Digits

Digit 14 — Fresh Air Selection

0 = None

A = Manual Outside Air Damper

B = Motorized Outside Air Damper

C = Economizer, Dry Bulb

D = Economizer, Dry Bulb with Barometric Relief

E = Economizer, Reference Enthalpy

F = Economizer, Reference Enthalpy with Barometric Relief

G = Economizer, Comparative Enthalpy

H = Economizer, Comparative Enthalpy with Barometric Relief

K = Downflow Low Leak Economizer, Reference Enthalpy with Barometric Relief

M = Downflow Low Leak Economizer, Reference Enthalpy with Barometric Relief

P = Downflow Low Leak Economizer, Comparative Enthalpy with Barometric Relief

R = Downflow Low Leak Economizer, Differential Dry Bulb with Barometric Relief

Digit 15 — Supply Fan

0 = Standard Motor

1 = Oversized Motor

2 = Single Zone Variable Air Volume with Standard Motor

3 = Single Zone Variable Air Volume with Oversized Motor

4 = Multiple Zone Variable Air Volume with Standard Motor

5 = Multiple Zone Variable Air Volume with Oversized Motor

Digit 16 — Hinged Access/Filters

0 = Standard Panels

A = Hinged Access Panels

B = Standard Panels with 2-in. MERV 8 Filters

C = Hinged Access Panels with 2-in. MERV 8 Filters

D = Standard Access Panels with 2-in. MERV 13 Filters

E = Hinged Access Panels with 2-in. MERV 13 Filters

Digit 17 — Coil Protection

0 = None

Digit 18 — Through-the-Base Provisions

0 = None

A = Through-the-Base Electric

Digit 19 — Disconnect/Circuit Breaker

0 = None

1 = Non-Fused Disconnect Switch

2 = Circuit Breaker

Digit 20 — Convenience Outlet

0 = None

A = Unpowered 20A Convenience Outlet

B = Powered 15A Convenience Outlet

Digit 21 — Communications

0 = None

1 = Advanced Controller with BACnet®/Modbus Communications

2 = Advanced Controller with LonTalk® Communications Interface (LCI)

3 = Advanced Diagnostics and Air-Fi® Wireless Communications Interface (WCI)

Digit 22 — Refrigeration System Option

0 = Standard Refrigeration System

A = Dehumidification Coil (Modulating HGRH)

Digit 23 — Controls Expansion Module

0 = None

1 = Symbio 700 XM-30 Expansion Module

2 = Symbio 700 XM-32 Expansion Module

3 = Symbio 700 XM-30 and XM-32 Expansion Modules

4 = 2X XM30

5 = 2X XM32

Digit 24 — Smoke Detector

0 = None

A = Return Air

B = Supply Air

C = Return and Supply Air

Digit 25 — System Monitoring Controls

- 0 = None
- 1 = Clogged Filter Switch (CFS)
- 2 = Condensate Overflow Switch (COS)
- 3 = Discharge Air Sensing Tube (DAS)
- 4 = CFS and COS
- 5 = CFS and DAS
- 6 = COS and DAS
- 7 = CFS and COS and DAS

Digit 26 — Not Used**Digit 27 — Hardware Enhancements**

- 0 = No Hardware Enhancements
- 1 = Stainless Steel Drain Pan

Digit 28 — Short Circuit Current Rating

- 0 = Standard (5k) SCCR Marking
- A = Tier 2 (65K) SCCR Marking

Digit 29 — Not Used**Digit 41 — Heat Exchanger**

- 1 = Copper-Water Coil
- 2 = Cupro-Nickel Water Coil
- 7 = Insulated Copper-Water Coil
- 8 = Insulated Cupro-Nickel Water Coil

Digit 42 — Freeze Protection

- A = 20°F Freezestat (For Glycol Loop)
- B = 35°F Freezestat (For Water Loop)

Digit 43 — Special

- 0 = Standard Unit
- S = Special Unit



General Information

Unit Inspection

To protect against loss due to damage incurred in transit, perform inspection immediately upon receipt of the unit. Check carefully for shipping damage. If any damage is found, report it immediately, and file a claim against the transportation company.

Exterior Inspection

If the job site inspection reveals damage or material shortages, file a claim with the carrier immediately. Specify the type and extent of the damage on the bill of lading before signing. Notify the appropriate sales representative.

Important: Do not proceed with installation of a damaged unit without sales representative approval.

- Inspect the complete exterior for signs of shipping damages to unit or packing material.
- Verify that the nameplate data matches the sales order and bill of lading.
- Verify that the unit is properly equipped and there are no material shortages.
- Verify the power supply complies with the unit nameplate specifications.

Inspection for Concealed Damage

Inspect the components for concealed damage as soon as possible after delivery and before it is stored.

If concealed damage is discovered:

- Notify the carrier's terminal of the damage immediately by phone and by mail.
- Concealed damage must be reported within 15 days.
- Request an immediate, joint inspection of the damage with the carrier and consignee.
- Stop unpacking the unit.
- Do not remove damaged material from receiving location.
- Take photos of the damage, if possible.
- The owner must provide reasonable evidence that the damage did not occur after delivery.

Unit Storage

Take precautions to prevent condensate from forming inside the unit's electrical compartments and motors if:

- The unit is stored before it is installed; or,
- The unit is set on the roof curb, and temporary heat is provided in the building. Isolate all side panel service entrances and base pan openings (e.g., conduit holes, S/A and R/A openings, and water inlet/outlet) from the ambient air until the unit is ready for start-up.

Note: Do not use the unit heater for temporary heat without first completing the start-up.

The manufacturer will not assume any responsibility for equipment damage resulting from condensate accumulation on the unit electrical and/or mechanical components.

Unit Description

Before shipment, each unit is leak tested, dehydrated, charged with refrigerant and compressor oil, and run tested for proper control operation.

All units come with standard Symbio™ 700 control system with advanced diagnostics.

Door Handles

Door handles rotate 180 degrees for use on either left- or right-handed doors. Handles will be in the vertical position when latched, as shown in the following figure.

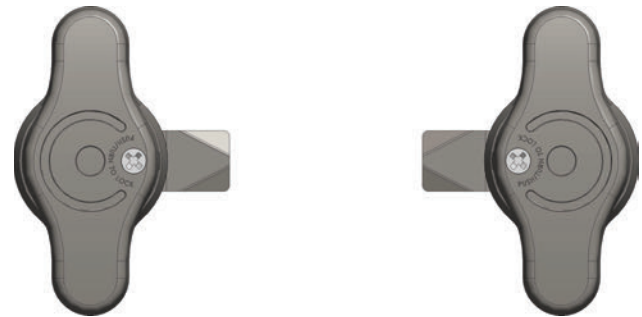

To lock:

1. Verify handle is in the vertical (latched) position.
2. Using a Phillips head screwdriver, push and rotate the handle screw clockwise 1/4 turn.

To unlock:

Use a Phillips head screwdriver to push and rotate handle screw counterclockwise 1/4 turn.

Unit Nameplate

A Mylar unit nameplate is located on the unit's corner support next to the filter access panel. It includes the unit model number, serial number, electrical characteristics, refrigerant charge, as well as other pertinent unit data.

Compressor Nameplate

The nameplate for the compressors are located on the side of the compressor.

LonTalk Communication Interface (Optional)

The Symbio™ controllers supports communication with LonTalk® open protocol applications. An advanced license is required to enable this feature. The LonTalk module is available factory supplied or as a field-installed kit.

BACnet Communications Interface (Optional)

The Symbio™ controller provides integrated communication with BACnet® open protocol applications. An advanced license is required to enable this feature. When enabled, the following selections are available: BACnet MS/TP, BACnet IP, or BACnet Zigbee® (Air-Fi®).

System Input Devices and Functions

The Symbio™ 700 controller requires a zone sensor or thermostat input to operate the unit in a CVZT or VVZT configuration.

Note: Use of a conventional thermostat will reduce unit functionality.

The number of available modes depends on the type of zone sensor or thermostat selected. Descriptions of the basic input devices used with the Symbio 700 network are provided to acquaint the operator with the various modules. Refer to the unit schematic for specific module connections. The following controls are available from the factory for field installation.

Supply Fan Failure

Supply Fan Proving is active when the Supply Fan is commanded ON. The supply fan speed must be greater than 30 rpm for 40 continuous seconds. If the supply fan speed falls below 30 rpm, supply fan failure diagnostic is generated, and operation is stopped.

Clogged Filter Switch (Optional)

The unit mounted clogged filter switch monitors the pressure differential across the return air filters. It is mounted in the filter section and is connected to the Fresh Air Options Module. A diagnostic signal is sent to the controller if the pressure differential across the filters is at least 0.5 inch w.c. The contacts will automatically open when the pressure differential across the filters decreases to approximately 0.4 inch w.c. The clogged filter output is energized when the supply fan is operating and the clogged filter switch has been closed for at least 2 minutes. The system will continue to operate regardless of the status of the filter switch. For further details, see *Clogged Filter Switch - Installation Instructions* (ACC-SVN238*-EN).

Note: On units equipped with factory installed MERV 13 filters, a clogged filter switch with different pressure settings will be installed. This switch will close when the differential pressure is approximately 0.8 inch w.c. and open when the differential falls to 0.7 inch w.c.

Condensate Drain Pan Overflow Switch

A condensate overflow condition will be detected by a condensate overflow float switch. When the condensate level reaches the trip point, the diagnostic condition will be detected. When the condensate overflow input CLOSES for six continuous seconds, the following actions will be taken by the Symbio™ 700 controls:

- An auto-reset diagnostic will be generated. All compressor or heating operations will be disabled immediately. Compressors will be de-energized. Supply fan operation will be shutdown.
- Once the overflow condition has been cleared and the input is OPEN for six seconds, all diagnostic conditions will be cleared. The unit will return to normal operation. Auto-reset clearing will occur twice each time the unit is powered up. On the third occurrence, the unit will initiate a lock-out and require manual reset. If an auto-reset overflow occurs once, but does not occur again for 72 hours, the trip counter will reset allowing more auto-resets to occur.

Compressor Disable (CPR1/2)

This input incorporates the low pressure control (LPC) of each refrigeration circuit.

If this circuit is open before the compressor is started, the compressor will not be allowed to operate. Anytime this circuit is opened for one continuous second during compressor operation, the compressor for that circuit is immediately turned OFF. The compressor will not be allowed to restart for a minimum of three minutes should the contacts close.

If four consecutive open conditions occur during the first three minutes of operation, the compressor for that circuit will be locked out, a diagnostic communicated to the remote panel (if installed), and a manual reset will be required to restart the compressor.

Low Pressure Control

When the LPC is opened for 1 continuous second, the compressor for that circuit is turned off immediately. The compressor will not be allowed to restart for a minimum of 3 minutes.

If four consecutive open conditions occur during an active call for cooling, the compressor will be locked out, a diagnostic generated, if applicable, and a manual reset required to restart the compressor.



High Pressure Control

The high pressure controls are wired in series between the compressor outputs on the Symbio™ controller and the compressor contactor coils. If the high pressure control switch opens, the controller senses a lack of current while calling for cooling and locks the compressor out.

If four consecutive open conditions occur during an active call for cooling, the compressor will be locked out, a diagnostic generated, if applicable, and a manual reset required to restart the compressor.

Zone Sensors

Manual Changeover (BAYSENS107*)

This sensor features three system switch settings (Heat, Cool, and Off) and two fan settings (On and Auto). It is a manual changeover control with single setpoint.

Manual/Automatic Changeover (BAYSENS109*)

This sensor features four system switch settings (Heat, Cool, Auto, and Off) and two fan settings (On and Auto). It is a manual or auto changeover control with dual setpoint capability. It can be used with a remote zone temperature sensor BAYSENS077*.

Wall Mounted Relative Humidity Sensor (BAYSENS036*)

Field installed, wall mounted humidity sensor that measures temperature and relative humidity. Relative humidity input is used to control activation of dehumidification

Duct Mounted Relative Humidity Sensor (BAYSENS037*)

Field installed, duct mounted humidity sensor that measures temperature and relative humidity. Relative humidity input is used to control activation of dehumidification.

Integrated Comfort System (BAYSENS073*)

This sensor features remote zone sensing and timed override with override cancellation. It is used with a Trane Integrated Comfort™ building management system.

Integrated Comfort System (BAYSENS074*)

This sensor features single setpoint capability and timed override with override cancellation. It is used with a Trane Integrated Comfort™ building management system.

Remote Zone Sensor (BAYSENS016*)

This bullet type temperature sensor can be used for outside air (ambient) sensing, return air temperature sensing, supply air temperature sensing, remote temperature sensing (uncovered). Wiring procedures vary according to the particular application and equipment involved. Refer to the unit's wiring diagrams for proper connections.

Remote Zone Sensor (BAYSENS077*)

This sensor can be used with BAYSENS800* Remote Panels. When this sensor is wired to a BAYSENS800* Remote Panel, wiring must be 18 AWG Shielded Twisted Pair (Belden 8760 or equivalent). Refer to the specific Remote Panel for wiring details.

Thermostat

The unit must have a thermostat to operate.

Note: Not compatible with VAV units.

- BAYSTAT152
Three Heat/Two Cool touchscreen digital display thermostat with built-in humidity control.
- BAYSTAT814
Three Heat/Two Cool **Pivot® Web Enabled Smart Thermostat**. It is great for commercial buildings with its intuitive touchscreen and customizable display.
- BAYSENS150
Three Heat/Two Cool Auto changeover digital display thermostat. Seven day programmable thermostat with night setback.

High Temperature Sensor (FIAHTST001*)

This sensor connects to the Symbio™ 700 Emergency Stop Input and provides high limit "shutdown" of the unit. The sensor is used to detect high temperatures due to a high thermal event in the air conditioning or ventilation ducts. The sensor is designed to mount directly to the sheet metal duct. Each kit contains two sensors. The return air duct sensor (X13100040010) is set to open at 135°F. The supply air duct sensor (X13100040020) is set to open at 240°F. The control can be reset after the temperature has been lowered approximately 25°F below the cutout setpoint.

Digital Display Zone Sensor (BAYSENS135*)

LCD display provides heat, cool, auto, on, and off status. Display includes two temperature setpoints, and a lockable setting with °F or °C indicators.

Touch Screen Programmable Zone Sensor (BAYSENS800)

This sensor uses a BACnet® MS/TP link to communicate zone temperature and setpoints. Sensor includes Auto, Heat, Cool, or Off system switch, as well as Fan Auto or On switch. This is a seven day programmable thermostat with night setback.

Notes:

- Not compatible with VAV units. Requires BACnet® communications.
- For additional sensors, refer to the product catalog.

Note: BASYSENS800* with BACnet® enabled on the Symbio™ controller will report fault detection and diagnostics at the zone sensor. This functionality is only applicable if the customer does not have a building management system, and the unit is running standalone with the BAYSENS800.

Evaporator Frost Control

Frostat is standard on all units.

Discharge Line Temp Switch (DLTS)

The DLTS is looped in series with HPC and LPC. It prevents the compressor from overheating (over 300°F dome temp).

Smoke Detector Sensor (Optional)

This sensor provides high limit “shutdown” of the unit and requires a manual reset. The sensor is used to detect smoke in the air conditioning or ventilation ducts.

Notes:

- The supply air smoke detector samples supply air. The return smoke detectors sample return air. The smoke detectors are designed to shut off the unit if smoke is sensed. This function is performed by sampling the airflow entering the unit at the return air opening. Follow the instructions provided below to assure that the airflow through the unit is sufficient for adequate sampling. Failure to follow these instructions will prevent the smoke detectors from performing its design function.
- Airflow through the unit is affected by the amount of dirt and debris accumulated on the indoor coil and filters. To insure that airflow through the unit is adequate for proper sampling by the return air smoke detector, complete adherence to the maintenance procedures, including recommended intervals between filter changes, and coil cleaning is required.
- Periodic checks and maintenance procedures must be performed on the smoke detector to insure that it will function properly. For detailed instructions concerning these checks and procedures, refer to the appropriate section(s) of the smoke detector Installation and Maintenance Instructions provided with the literature package for this unit.
In order for the supply air smoke detector or return air smoke detector to properly sense smoke in the supply air stream or return air stream, the air velocity entering the smoke detector unit must be between 500 and 4000 feet per minute. Equipment covered in this manual will develop an airflow velocity that falls within these limits over the entire airflow range specified in the evaporator fan performance tables.

Phase Monitor

This sensor monitors voltage between the 3 conductors of the 3 phase power supply. Two LED lights are provided:

- The green light indicates that a balanced 3 phase supply circuit is properly connected.
- The red light indicates that unit operation has been prevented. There are two conditions that will prevent unit operation:
 - The power supply circuit is not balanced with the proper phase sequence of L1, L2, L3 for the 3 conductors of a 3 phase circuit.
 - The line to line voltage is not between 180 volts and 633 volts.



General Information

Operating Limits

Table 1. Operating limits

| Operating Limits | Cooling | Heating |
|---------------------------------|------------------------------------|---------------------|
| Air limits | | |
| Min. ambient air DB | 45°F (7°C) | |
| Max. ambient air DB | 130°F (54.4°C) | |
| Min. EAT DB/WB | 55/46°F (12.2/7.8°C) | 55.0°F/- (12.8°C/-) |
| Max. EAT DB/WB | 90/79°F (32.2/26.1°C) | 80°F/- (26.7°C/-) |
| Airflow range | 300 to 480 CFM/ton ^(a) | |
| Water limits | | |
| Min. entering water temperature | 45°F (7°C) | 25°F (-4°C) |
| Max. entering water temperature | 120°F (49°C) | 86°F (30°C) |
| Max. water pressure | 400 PSIG (2758 kPa) | |
| Water flow range | 2.0 to 3.75 GPM/ton ^(a) | |

^(a) See performance tables for each model's rated values.



Pre-Installation

⚠ WARNING

Fiberglass Wool!

Exposure to glass wool fibers without all necessary PPE equipment could result in cancer, respiratory, skin or eye irritation, which could result in death or serious injury. Disturbing the insulation in this product during installation, maintenance or repair will expose you to airborne particles of glass wool fibers and ceramic fibers known to the state of California to cause cancer through inhalation.

You **MUST** wear all necessary Personal Protective Equipment (PPE) including gloves, eye protection, a NIOSH approved dust/mist respirator, long sleeves and pants when working with products containing fiberglass wool.

Precautionary Measures:

- Avoid breathing fiberglass dust.
- Use a NIOSH approved dust/mist respirator.
- Avoid contact with the skin or eyes. Wear long-sleeved, loose-fitting clothing, gloves, and eye protection.
- Wash clothes separately from other clothing; rinse washer thoroughly.
- Operations such as sawing, blowing, tear-out, and spraying may generate fiber concentrations requiring additional respiratory protection. Use the appropriate NIOSH approved respirator.

First Aid Measures:

- **Eye Contact** - Flush eyes with water to remove dust. If symptoms persist, seek medical attention.
- **Skin Contact** - Wash affected areas gently with soap and warm water after handling.

Precautionary Measures

- Avoid breathing fiberglass dust.

- Use a NIOSH approved dust/mist respirator.
- Avoid contact with the skin or eyes. Wear long-sleeved, loose-fitting clothing, gloves, and eye protection.
- Wash clothes separately from other clothing: rinse washer thoroughly.
- Operations such as sawing, blowing, tear-out, and spraying may generate fiber concentrations requiring additional respiratory protection. Use the appropriate NIOSH approved respiration in these situations.

First Aid Measures

Eye Contact - Flush eyes with water to remove dust. If symptoms persist, seek medical attention.

Skin Contact - Wash affected areas gently with soap and warm water after handling.

⚠ WARNING

Hazardous Voltage!

Failure to disconnect power before servicing could result in death or serious injury.

Disconnect all electric power, including remote disconnects before servicing. Follow proper lockout/tagout procedures to ensure the power can not be inadvertently energized. Verify that no power is present with a voltmeter.

1. Remove power to the unit and gain access to the electric heat elements by removing the horizontal supply cover.
2. Visually inspect the heater elements for the following:
 - a. Elements that are no longer secured to the white ceramic insulator.
 - b. Elements touching each other or touching metal.
 - c. Severely kinked, drooping, or broken elements.
3. If an element has detached from its ceramic insulator, carefully put it back into place.
4. Replace the heater elements if they present symptoms noted in the above Step 2.a and 2.c.



A2L Information

A2L Work Procedures

⚠ WARNING

Risk of Fire — Flammable Refrigerant!

Failure to follow instructions below could result in death or serious injury, and equipment damage.

- To be repaired only by trained service personnel.
- Do not puncture refrigerant tubing.
- Dispose of properly in accordance with federal or local regulations.

⚠ WARNING

Refrigerant under High Pressure!

Failure to follow instructions below could result in an explosion which could result in death or serious injury or equipment damage.

System contains refrigerant under high pressure. Recover refrigerant to relieve pressure before opening the system. See unit nameplate for refrigerant type. Do not use non-approved refrigerants, refrigerant substitutes, or refrigerant additives.

⚠ WARNING

Hazardous Voltage!

Failure to disconnect power before servicing could result in death or serious injury.

Disconnect all electric power, including remote disconnects before servicing. Follow proper lockout/tagout procedures to ensure the power can not be inadvertently energized. Verify that no power is present with a voltmeter.

The units described in this manual use R-454B refrigerant. Use ONLY R-454B rated service equipment or components with these units. For specific handling concerns with R-454B, contact your local Trane representative.

Installation, repair, removal, or disposal should be performed by trained service personnel.

At all times, Trane's maintenance and service guidelines shall be followed. If in doubt, contact Trane technical support for assistance.

Service

Prior to initiating work on equipment, check the area with an appropriate refrigerant detector. Ensure the service personnel are properly trained regarding work in potentially toxic or flammable atmospheres. Ensure that the leak detection equipment being used is suitable for use with all applicable refrigerants, i.e. non-sparking, adequately

sealed, or intrinsically safe. Be aware that the refrigerant does not contain an odor.

If any hot work is to be conducted on the refrigerating equipment or any associated parts, appropriate fire extinguishing equipment shall be available on hand. A dry powder or CO₂ fire extinguisher should be located adjacent to the charging area.

At all times, Trane's maintenance and service guidelines shall be followed. If in doubt, contact Trane technical support for assistance.

All maintenance staff and others working in the local area shall be instructed on the nature of the work being carried out. Work in confined spaces shall be avoided.

Ignition Source Mitigation

Do not use any sources of ignition when working on the refrigeration system.

Keep all ignition sources, including cigarette smoking, away from the site of installation, repair, removal or disposal, during which refrigerant can potentially be released to the surrounding space.

Survey the area around the equipment before initiating work to ensure no flammable hazards or ignition risks are present.

"No Smoking" signs shall be displayed.

Do not use devices that can be a source of ignition to accelerate defrosting of components. Use only defrost and cleaning procedures recommended by Trane. Do not pierce or burn.

Ventilation

Ensure that the area is in the open or that it is adequately ventilated before breaking into the system or conducting any hot work. A degree of ventilation shall continue during the period that the work is carried out. The ventilation should safely disperse any released refrigerant and preferably expel it externally into the atmosphere. If present, check that the ventilation system, including outlets, are operating adequately and are not obstructed.

Refrigerating Equipment

Refrigerant piping or components should not be installed in locations where substances which may corrode them are present.

Check that equipment hazard markings are visible and legible. Replace them if they are not.

For equipment using secondary fluids, like water or glycol, check that refrigerant is not present in the secondary fluid loop before conducting any hot work.

Electrical Devices

Do not apply power to the circuit if a fault exists which compromises safety. If the fault cannot be corrected immediately, but it is necessary to continue operation, an

adequate temporary solution shall be used. This shall be reported to the owner of the equipment, so all parties are advised.

Initial safety checks shall include:

- Cabling is not subject to wear, corrosion, excessive pressure, vibration, sharp edges, or any other adverse environmental effects. Account for the effects of aging or continual vibration from sources such as compressors or fans.
- Capacitors are discharged. This shall be done in a safe manner to avoid possibility of sparking.
- No live electrical components and wiring are exposed while charging, recovering, or purging the system.
- Verify continuity of earth bonding.
- Replace electrical components with Trane replacement parts, or those meeting the same ratings and qualified for flame arrest protection, UL LZGH2 category.

Leak Detection

Never use an open flame to detect leaks. A halide torch should not be used. Use only approved leak detection methods per this instruction manual.

The following leak detection methods are deemed acceptable for all refrigerant systems.

Electronic leak detectors may be used to detect refrigerant leaks but, in the case of flammable refrigerants, the sensitivity may not be adequate, or may need re-calibration. (Detection equipment shall be calibrated in a refrigerant-free area.) Ensure that the detector is not a potential source of ignition and is suitable for the refrigerant used. Leak detection equipment shall be set at a percentage of the LFL gas (25% maximum) is confirmed.

Leak detection fluids are also suitable for use with most refrigerants but the use of detergents containing chlorine shall be avoided as the chlorine may react with the refrigerant and corrode the copper pipe-work.

Examples of leak detection fluids are:

- Bubble method
- Fluorescent method agents

If a leak is suspected, all naked flames shall be removed/ extinguished.

If a refrigerant leak is found which requires brazing, all refrigerant shall be recovered from the system, or isolated (by means of shut off valves) in a part of the system remote from the leak.

Refrigerant Removal and Evacuation

Ensure that the correct number of cylinders for holding the total system charge is available. All cylinders to be used are designated for the recovered refrigerant and labeled for that refrigerant (special cylinders for the recovery of refrigerant, for example). Cylinders shall be complete with pressure-relief valve and associated shut-off valves in good

working order. Empty recovery cylinders are evacuated and, if possible, cooled before recovery occurs.

When breaking into the refrigerant circuit to make repairs – or for any other purpose – conventional procedures shall be used. However, for flammable refrigerants it is important that best practice be followed, since flammability is a consideration.

The following procedure shall be adhered to:

1. Safely remove refrigerant following local and national regulations.
2. Evacuate.
3. Purge the circuit with inert gas.
4. Evacuate (optional for A2L).
5. Continuously flush or purge with inert gas when using flame to open circuit.
6. Open the circuit.

Prior to refrigerant removal, open all appropriate valves, including solenoid and electronic expansion valves (EXVs). Use control settings, where available. When not available, manually open all electronically controlled valves using acceptable service procedures.

The recovery equipment shall be in good working order with instructions available. Equipment shall be suitable for the recovery of the flammable refrigerant. For specific handling concerns, contact the manufacturer. Ensure all hose connections are checked for tightness to avoid refrigerant leaks.

The refrigerant shall be recovered into the correct recovery cylinders if venting is not allowed by local and national codes. Do not mix refrigerants in recovery unit and especially not in cylinders.

Refrigerant recovery unit should be purged with an inert gas after each use or before using with a different refrigerant Class – for example, A2L to A1.

If compressors or compressor oils are to be removed, ensure that they have been evacuated to an acceptable level to make certain that flammable refrigerant does not remain within the lubricant. The compressor body shall not be heated by an open flame or other ignition sources to accelerate this process. When oil is drained from a system, it shall be carried out safely.

The system shall be purged with oxygen-free nitrogen to render the appliance safe for flammable refrigerants. This process might need to be repeated several times. Compressed air or oxygen shall not be used for purging refrigerant systems.

The system shall be vented down to atmospheric pressure to enable work to take place.

The outlet for the vacuum pump shall not be close to any potential ignition sources, and ventilation shall be available.

Refrigerant Charging

In addition to conventional charging procedures, the following requirements shall be followed.



A2L Information

- Ensure that contamination of different refrigerants does not occur when using charging equipment.
- Hoses or lines shall be as short as possible to minimize the amount of refrigerant contained in them.
- Cylinders shall be kept in an appropriate position according to the instructions.
- Ensure that the refrigerating system is earthed prior to charging the system with refrigerant.
- Label the system when charging is complete (if not already).
- Extreme care shall be taken not to overfill the refrigerating system.

Prior to recharging the system, it shall be pressure-tested with the appropriate purging gas. The system shall be leak-tested on completion of charging but prior to commissioning. A follow up leak test shall be carried out prior to leaving the site.

Prior to refrigerant charging, open all appropriate valves, including solenoid and electronic expansion valves (EXVs). Use control settings, where available. When not available, manually open all electronically controlled valves using acceptable service procedures.

Decommissioning

Before carrying out the decommissioning procedure, it is essential that the trained service personnel is completely familiar with the equipment and all its details. It is recommended good practice that all refrigerants are recovered safely. Prior to the task being carried out, an oil and refrigerant sample shall be taken in case analysis is required prior to re-use of recovered refrigerant. It is essential that electrical power is available before the task is commenced.

1. Become familiar with the equipment and its operation.
2. Isolate system electrically.
3. Before attempting the procedure, ensure that:
 - a. Mechanical handling equipment is available, if required, for handling refrigerant cylinders.
 - b. All personal protective equipment is available and being used correctly.
 - c. The recovery process is supervised at all times by a competent person.
 - d. Recovery equipment and cylinders conform to the appropriate standards.
4. Pump down refrigerant system, if possible.
5. If a vacuum is not possible, make a manifold so that refrigerant can be removed from various parts of the system.
6. Make sure that cylinder is situated on the scales before recovery takes place.
7. Start the recovery machine and operate in accordance with instructions.

8. Do not overfill cylinders (no more than 80% volume liquid charge).
9. Do not exceed the maximum working pressure of the cylinder, even temporarily.
10. When the cylinders have been filled correctly and the process completed, make sure that the cylinders and the equipment are removed from site promptly and all isolation valves on the equipment are closed off.
11. Recovered refrigerant shall not be charged into another refrigerating system unless it has been cleaned and checked.
12. When equipment has been decommissioned, attach a signed label which includes the date of decommissioning.

A2L Application Considerations

This product is listed to UL standard 60335-2-40, Household and Similar Electrical Appliances – Safety – Part 2-40: Particular Requirements for Electrical Heat Pumps, Air-Conditioners and Dehumidifiers, which defines safe design and use strategies for equipment using A2L refrigerants. This standard limits the refrigerant concentration in a space in the event of a refrigerant leak. To meet the requirements, the UL standard defines minimum room area, refrigerant charge limit, minimum circulation airflow and/or ventilation airflow requirements, and limits the use of ignition sources in spaces. The standard may require a unit refrigerant leak detection system.

For equipment with R-454B and charge amounts less than or equal to 3.91 lbs per circuit, this UL standard does not prescribe a room area limit and does not require a refrigerant leak detection system or any circulation airflow or ventilation airflow mitigation strategies. However, ignition sources in ductwork must be evaluated.

Depending on the application, a specific requirement of ANSI/ASHRAE Standard 15, Safety Standard for Refrigeration Systems, could be more stringent than UL 60335-2-40 requirements. See *Refrigeration Systems and Machinery Rooms Application Considerations for Compliance with ASHRAE® Standard 15-2022 Application Engineering Manual* (APP-APM001*-EN) for more information.

Ignition Sources in Ductwork

Do not install open flames in the ductwork. Hot surfaces exceeding 700°C (1290°F) should not be installed in the ductwork unless the average airflow velocity is not less than 1.0 m/s (200 ft/min) across the heater and proof of airflow is verified before system is energized.

Electric heaters can exceed the surface temperature limit if airflow distribution is poor, or insufficient airflow is provided over the heater.

Surface temperatures of most gas heaters do not exceed the surface temperature limits due to ANSI construction requirements.

Ignition Sources in Unit

This unit does not contain any ignition sources. All potential ignition sources, (including factory or field installed accessory electric heaters, gas heaters, relays, and contactors) were evaluated during product UL listing.

Minimum Room Area Limits (Refrigerant charge greater than 3.91 lb per circuit)

Equipment with R-454B charge amounts greater than 3.91 lb per circuit may require additional circulation or ventilation airflow mitigation strategies. In this case, two minimum room area (A_{min}) thresholds:

- The first threshold defines when equipment serving a single room is required to provide circulation airflow,

either continuous or activated by a leak detection system. A ducted system requires circulation airflow unless the smallest room it serves is larger than the adjusted A_{min} threshold. This product contains a leak detection system if a circuit charge is greater than 3.91 lbs. As a result, no further leak detection system evaluation is required.

- The second threshold defines when additional ventilation airflow is required. If the room area, A or TA, is below the adjusted A_{min} or TA_{min} threshold, additional ventilation is required to remove refrigerant in the event of a leak. Refer to UL 60335-2-40 Clause GG.8 and ANSIASHRAE Standard 15 Section 7 for natural and mechanical ventilation requirements.

Table 2. Minimum room area

| Model | Charge Range | | Minimum Room Area | |
|--------|--------------|-----------|-------------------|----------------|
| | lbs | kg | ft ² | m ² |
| GSK036 | 6.1-6.6 | 2.7-2.9 | 91.3-98.8 | 8.4-9.1 |
| GSK048 | 7.9-8.6 | 3.5-3.8 | 118.3-128.7 | 10.9-11.9 |
| GSK060 | 8-8.5 | 3.6-3.8 | 119.8-127.2 | 11.1-11.8 |
| GSK072 | 15.2-16.8 | 6.8-7.6 | 227.6-251.5 | 21.1-23.3 |
| GSK090 | 15.5-17 | 7-7.7 | 232.1-254.5 | 21.5-23.6 |
| GSK102 | 16.5-18 | 7.4-8.1 | 247-269.5 | 22.9-25 |
| GSK120 | 21.5-24.9 | 9.7-11.2 | 321.9-372.8 | 29.9-34.6 |
| GSK150 | 31.5-37.5 | 14.3-17.0 | 471.7-561.5 | 43.8-52.2 |
| GSK180 | 32-33 | 14.4-14.9 | 479.2-494.1 | 44.5-45.9 |
| GSK210 | 31-33 | 14-14.9 | 464.2-494.1 | 43.1-45.9 |
| GSK240 | 38-42 | 17.2-19 | 569-628.9 | 52.8-58.4 |
| GSK300 | 35-36 | 15.8-16.3 | 524.1-539.1 | 48.6-50 |

Minimum Room Area (A_{min}) Adjustments

Use equation below to adjust the minimum room area, as applicable, based on the unit's installation height, altitude, and occupancy level it serves.

$$A_{min.adj} = \text{Nameplate } A_{min} \times \text{Altitude Adj} \times \text{Height Adj} \times F_{occ}$$

Multiply the altitude adjustment factor in the table below by A_{min} listed on the unit nameplate or in the Installation, Operation, and Maintenance (IOM) manual.

Table 3. Altitude adjustment factor

| Altitude (ft) | Sea Level to 2000 | 2001 to 4000 | 4001 to 6000 | 6001 to 8000 | 8001 to 10000 | 10001 to 12000 | 12001 to 14000 | 14001 to 15000 | Over 15000 |
|----------------------|-------------------|--------------|--------------|--------------|---------------|----------------|----------------|----------------|------------|
| A_{min} Adjustment | 1 | 1.05 | 1.11 | 1.17 | 1.24 | 1.32 | 1.41 | 1.51 | 1.57 |

In addition, A_{min} can be adjusted if the unit is installed in a room at a height that is higher than the minimum height shown on the unit. To adjust A_{min} , multiply by the ratio of the unit minimum release height (in meters) / actual release

height (in meters). Use 0.6 m in the ratio for unit minimum installation heights less than or equal to 0.6 m.

For institutional occupancies, ASHRAE Standard 15 applies an additional adjustment factor F_{occ} to the amount of a charge allowed in a space. To calculate the adjusted



A2L Information

A_{\min} for institutional occupancies, multiply the A_{\min} on the nameplate by two.

EXAMPLE 1: 20 Ton Packaged Rooftop Multi-Zone VAV System Serving an Institutional Occupancy Space

The packaged unit serves 7600 ft² of a nursing home located at an altitude of 4000 ft. The unit has two equally charged 10 ton refrigeration circuits. Each circuit has 12 lbs of refrigerant with a minimum room area requirement of 180 ft² with a 2.2 m release height.

$$TA_{\min.\text{adj}} = 180 \text{ ft}^2 \times 1.05 \times 2 = 378 \text{ ft}^2$$

No additional ventilation is required.

EXAMPLE 2: 10 Ton Split System Serving a Single Commercial Occupancy Space

The split system serves a 1500 ft² manufacturing space at 5000 ft altitude. The final installed charge of the single circuit 10 ton unit is 20 lb. The unit has an open return with a release height of 1 m and ducted supply air. The unit A_{\min} is 660 ft².

$$A_{\min.\text{adj}} = 660 \text{ ft}^2 \times 1.11 = 733 \text{ ft}^2$$

No additional ventilation is required.

Determining Room Area (A or TA)

The room area (A) is the room area enclosed by the projection to the floor of the walls, partitions, and doors of the space that the equipment serves. For ducted systems, total room area (TA) of all rooms connected by ducts, may be used instead of A.

Rooms connected by drop ceilings only are not considered a single room.

Rooms on the same floor of the building, and connected by an open passageway, can be considered part of the same room if the passageway is a permanent opening, extends to the floor and is intended for people to walk through.

Adjacent rooms on the same floor of the building and connected by permanent openings in the walls and/or doors between rooms (including gaps between the wall and

the floor), can be considered part of the same room if the openings meet the following criteria.

- The opening is permanent and cannot be closed.
- Openings extending to the floor, such as door gaps, need to be at least 20 mm above the floor covering surface.
- Natural ventilations opening areas must meet the requirements of ANSIASHRAE Standard 15-2022, Section 7.2.3.2.

Rooms that are connected by a mechanical ventilation system can be considered a single room area if the mechanical ventilation system meets the requirements of ANSIASHRAE Standard 15-2022, Section 7.6.4.

Leak Detection System (Refrigerant charge greater than 3.91 lb per circuit)

The leak detection system consists of one or more refrigerant detection sensors. When the system detects a leak, the following mitigation actions will be initiated until refrigerant has not been detected for at least 5 minutes:

- Energize the supply fan(s) to deliver a required minimum amount of circulation airflow.
- Disable compressor operation.
- Provide an output signal to fully open all zoning dampers, such as VAV boxes.
- Provide an output to energize additional mechanical ventilation (if needed).
- Units without airflow proving will disable electric heat sources.

Building fire and smoke systems may override this function.

If the refrigerant sensor has a fault, is at the end of its life, or is disconnected, the unit will initiate the mitigation actions. Mitigation actions may be verified by disconnecting the sensor.

The refrigerant sensors do not need service. Use only manufacturer-approved sensors when replacement is required.



Dimensions and Weights

Cabinet Size

Table 4. Cabinet size

| Unit Size (Tons) | Model Number Digits 4, 5, 6 | Model |
|------------------|-----------------------------|-------|
| | | GSK |
| 3 | 036 | A.0 |
| 4 | 048 | |
| 5 | 060 | |
| 6 | 072 | B.0 |
| 7.5 | 090 | |
| 8.5 | 102 | C.0 |
| 10 | 120 | |
| 12.5 | 150 | |
| 15 | 180 | D.0 |
| 17.5 | 210 | |
| 20 | 240 | D.1 |
| 25 | 300 | |

Dimensional Data

Figure 1. A.0 cabinet

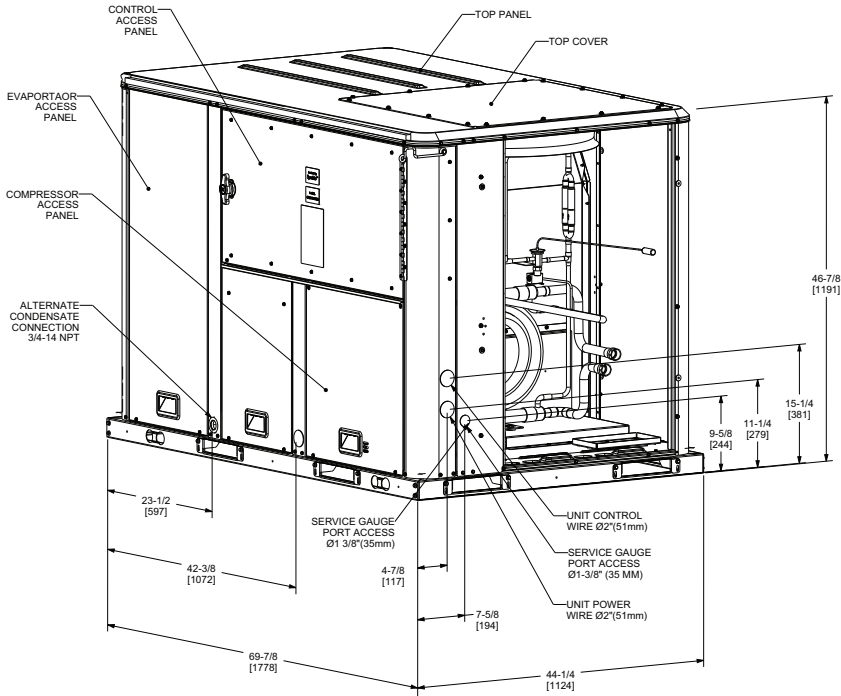



Dimensions and Weights

Figure 2. A.0 cabinet – downflow airflow supply/return, through-the-base utilities

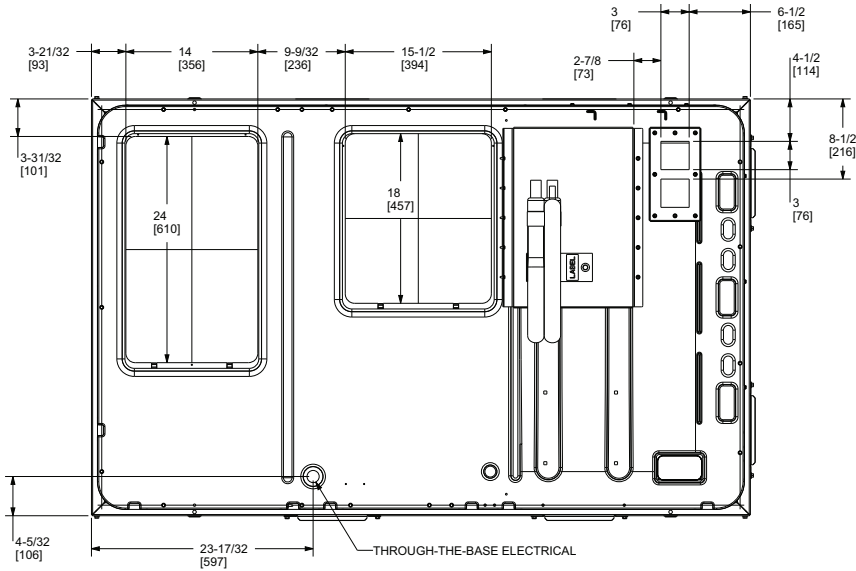

Figure 3. A.0 cabinet – horizontal airflow supply/return

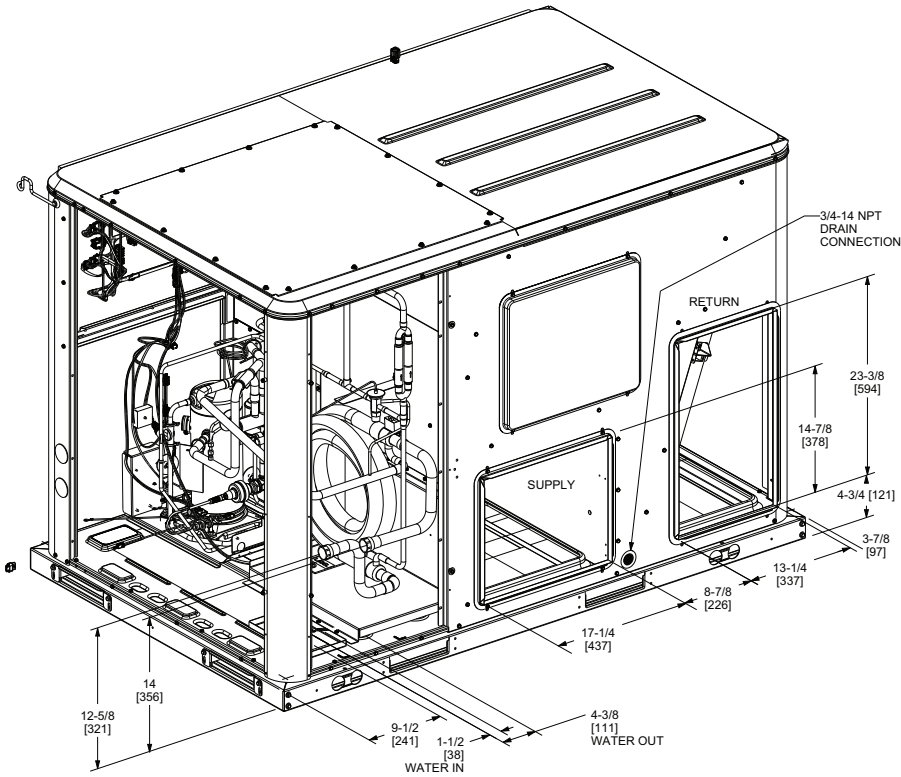

Figure 4. A.0 cabinet – unit clearance and roof opening

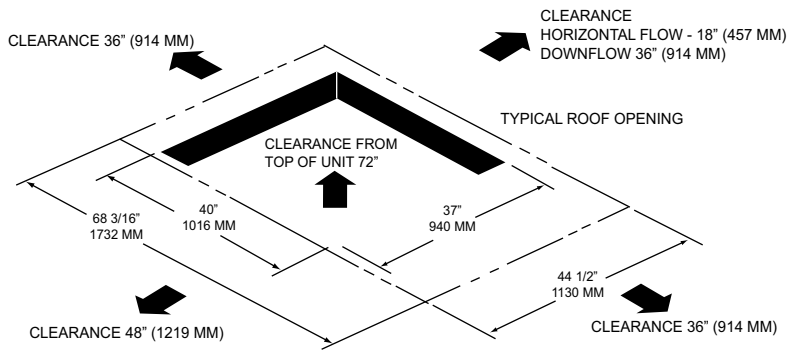
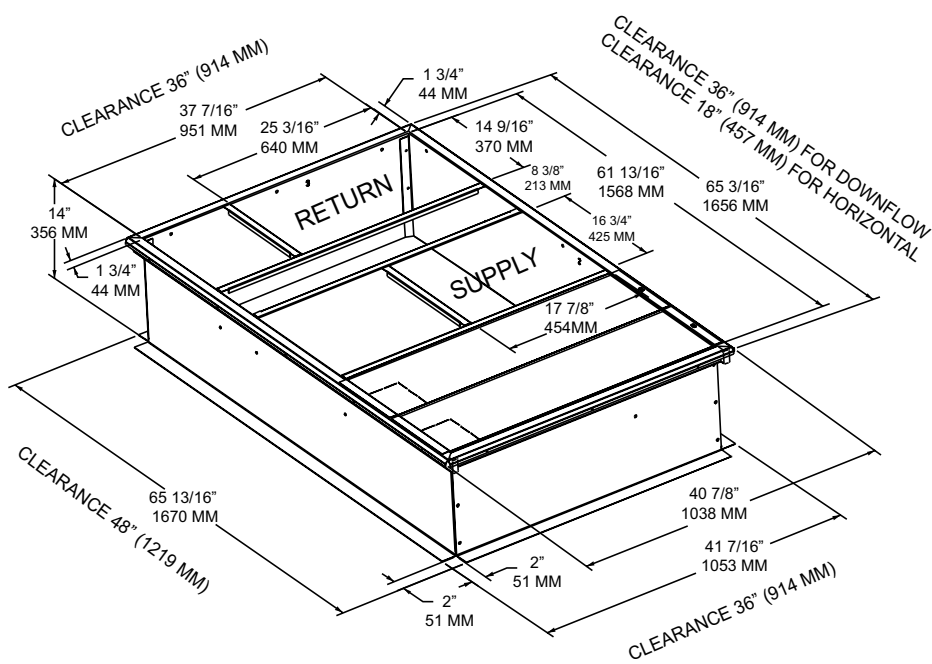

Figure 5. A.0 cabinet – roof curb





Dimensions and Weights

Figure 6. A.0 cabinet – downflow duct connections, field fabricated

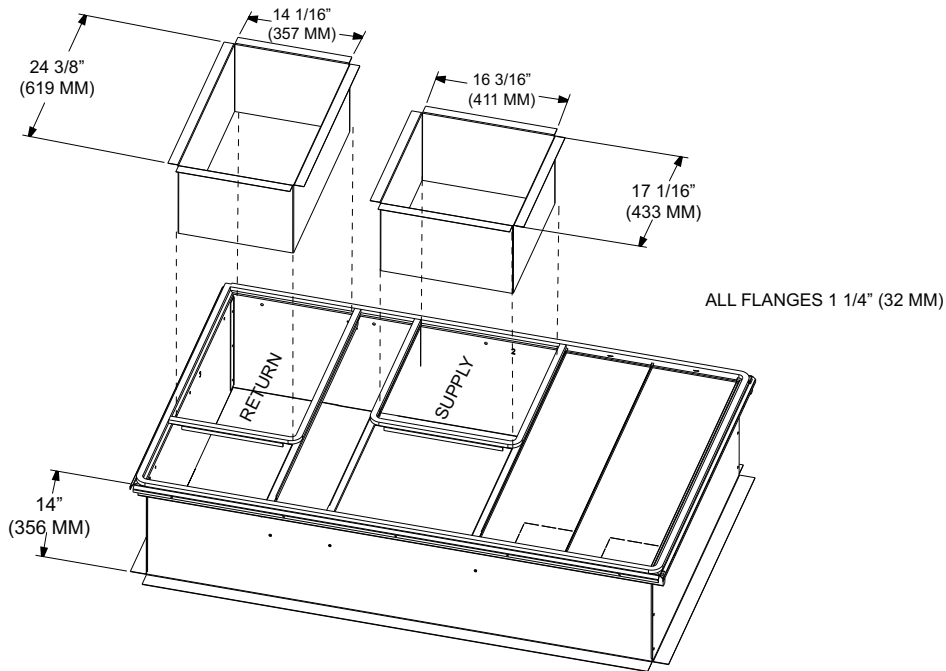

Figure 7. A.0 cabinet – swing diameter for hinged door(s) option

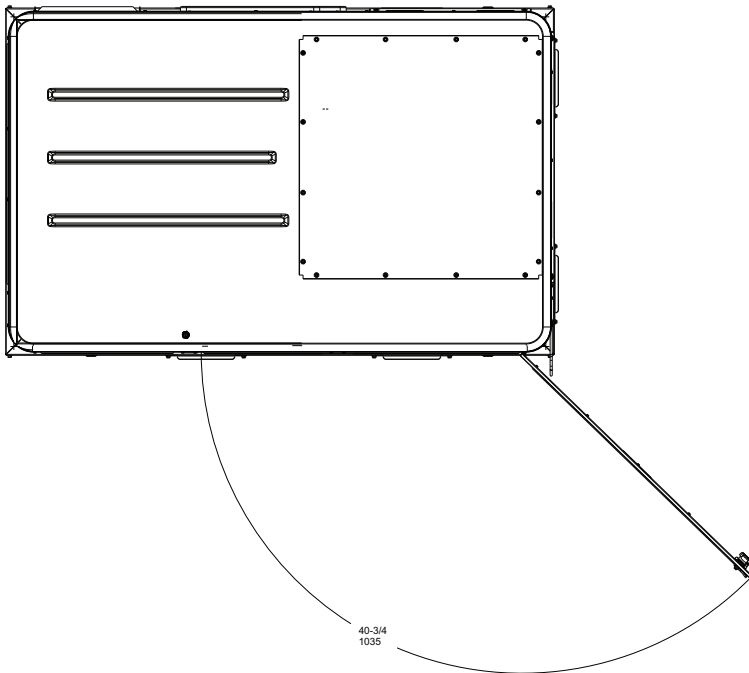

Figure 8. B.0 cabinet

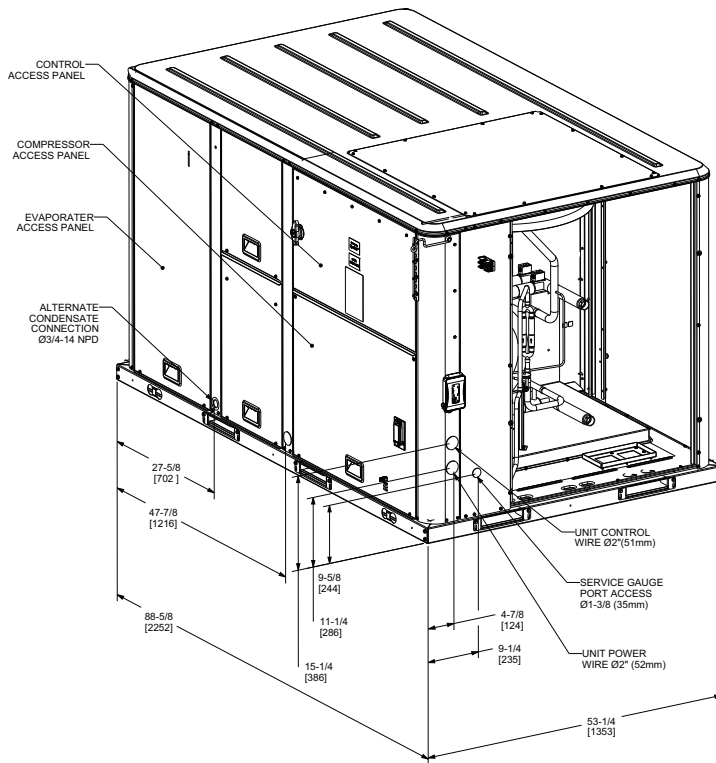
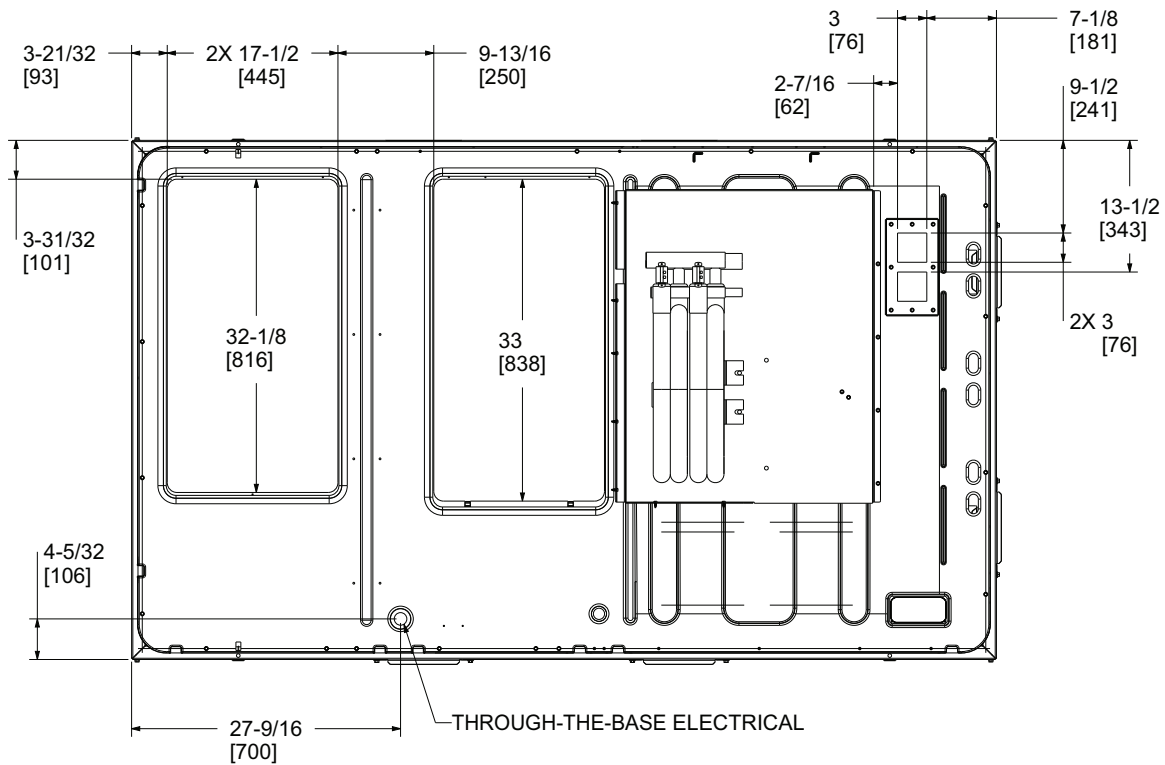

Figure 9. B.0 cabinet – downflow airflow supply/return, through-the-base utilities





Dimensions and Weights

Figure 10. B.0 cabinet – horizontal airflow supply/return

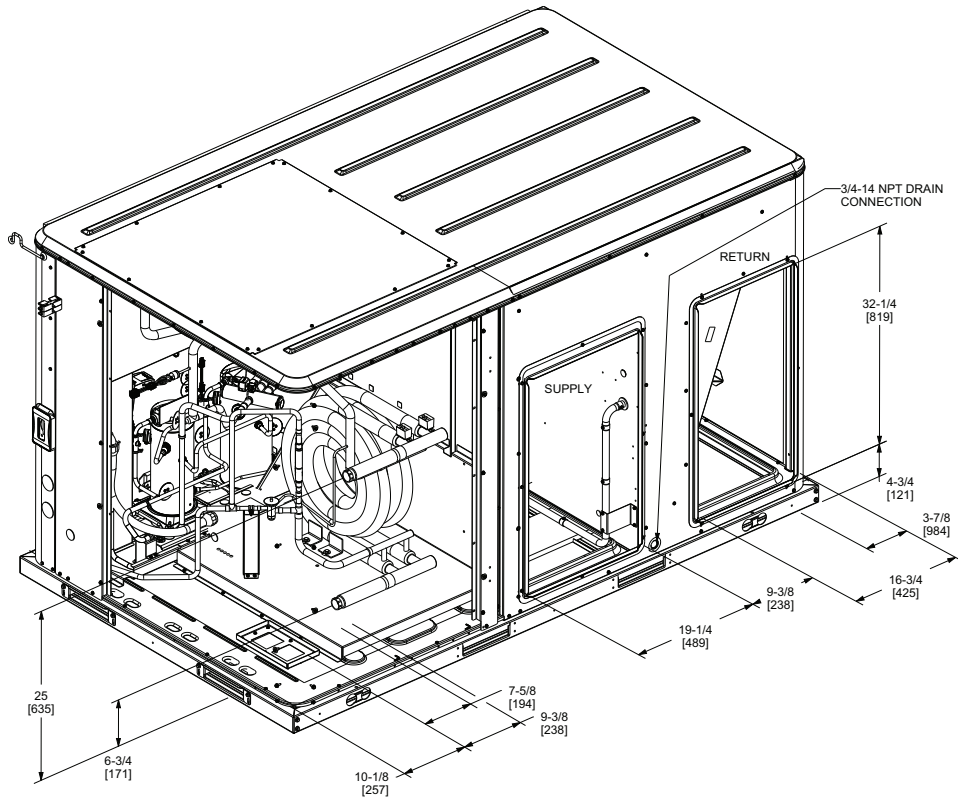
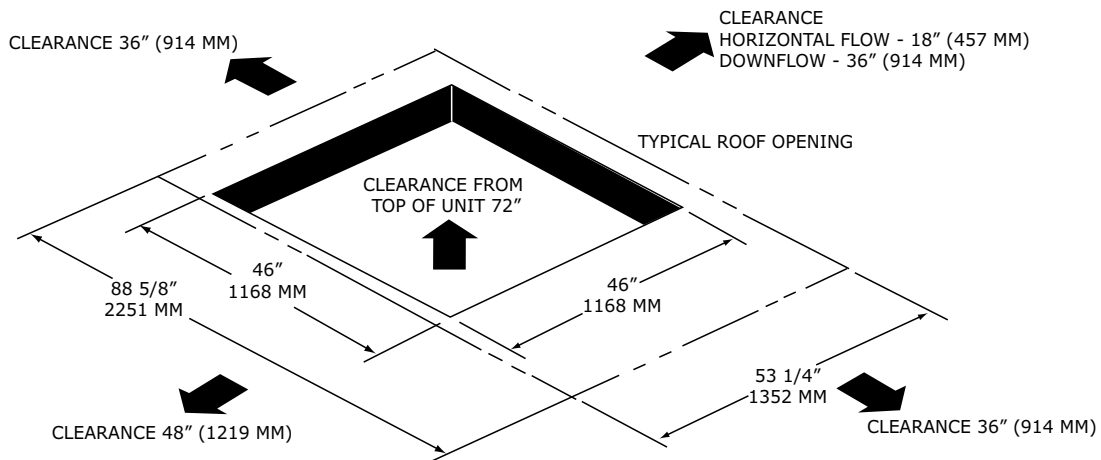

Figure 11. B.0 cabinet – unit clearance and roof opening





Dimensions and Weights

Figure 14. B.0 cabinet – swing diameter for hinged door(s) option

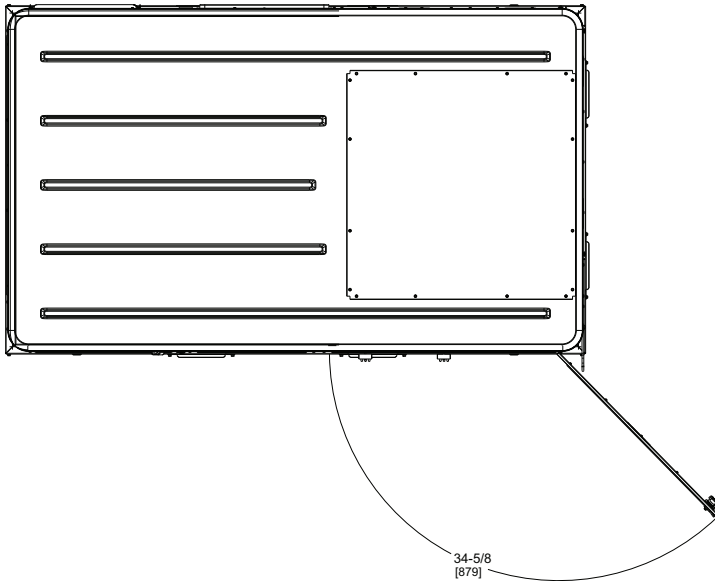

Figure 15. C.0 cabinet

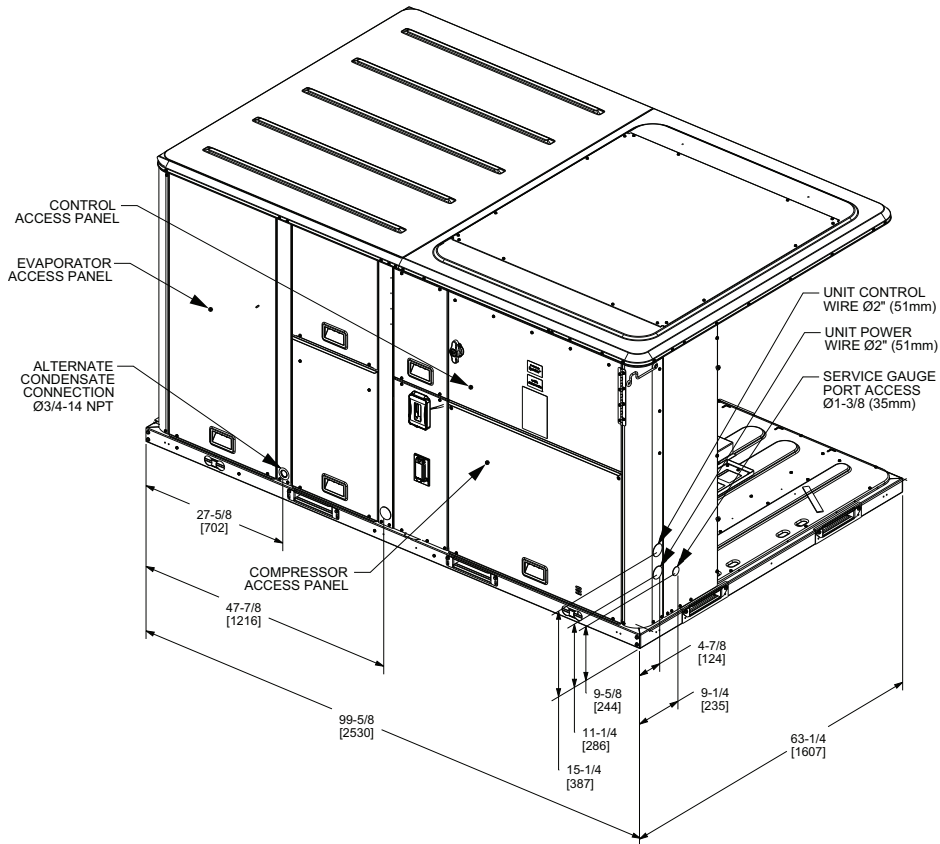

Figure 16. C.0 cabinet – downflow airflow supply/return, through-the-base utilities

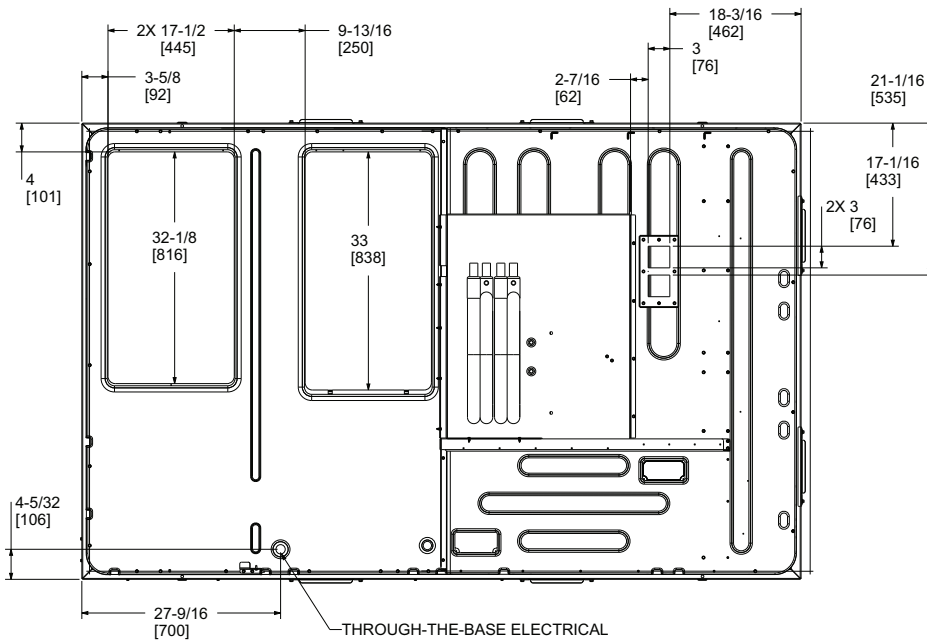

Figure 17. C.0 cabinet – horizontal airflow, supply and return

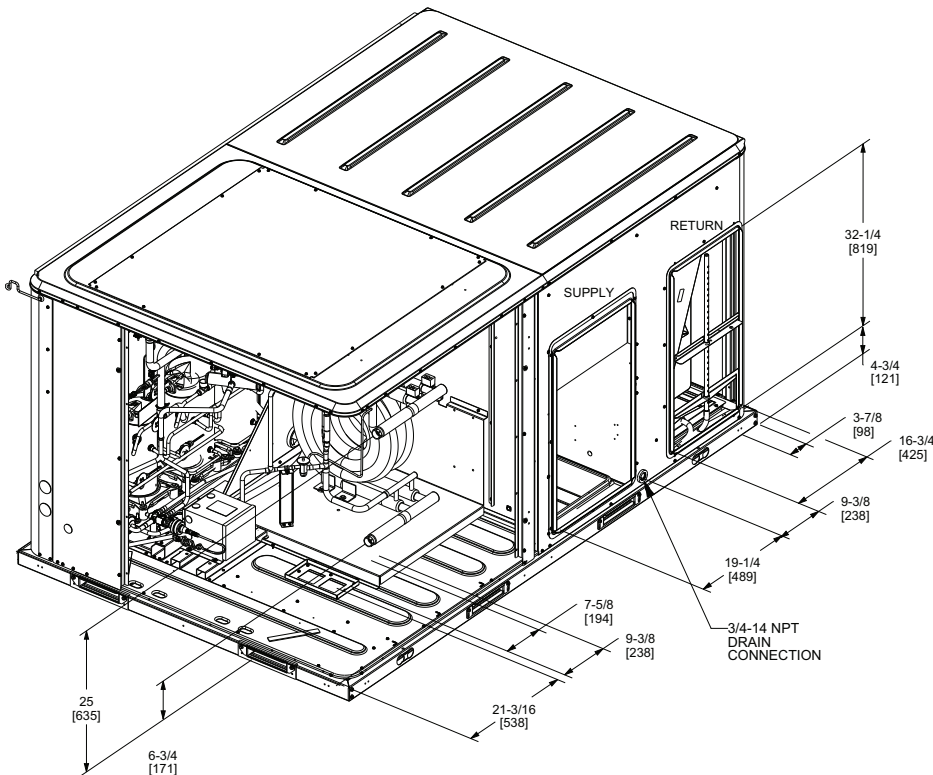

Figure 20. C.0 cabinet – swing diameter for hinged door(s) option

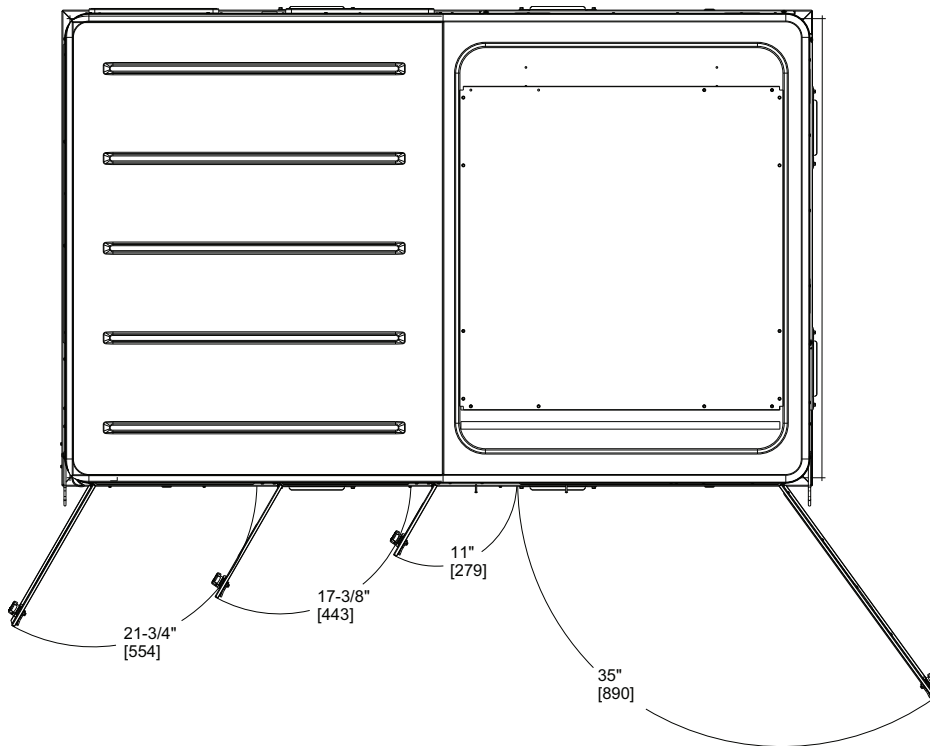
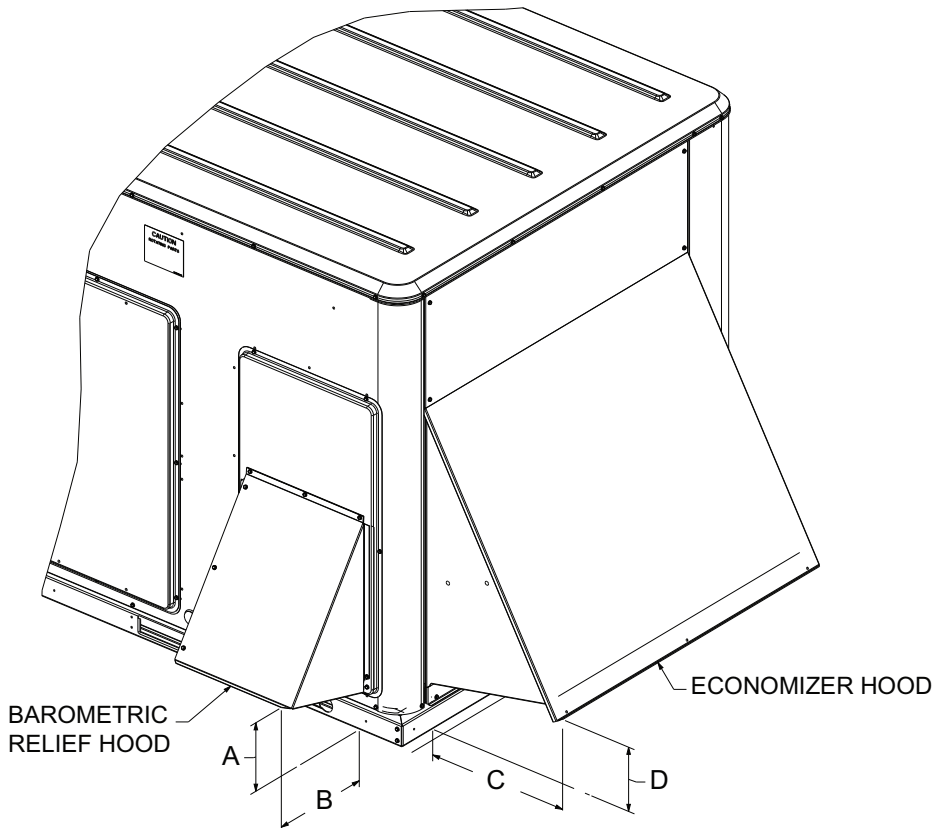

Figure 21. A.0, B.0 and C.0 cabinets – standard economizer, manual or motorized fresh air damper





Dimensions and Weights

| Cabinet | Dimension | | | | | | | |
|-------------|-----------|-----|-------|-----|--------|-----|-------|-----|
| | A | | B | | C | | D | |
| | inch | mm | inch | mm | inch | mm | inch | mm |
| A.0 | 6 7/8 | 175 | 9 1/8 | 232 | 12 1/2 | 318 | 6 1/4 | 159 |
| B.0 and C.0 | 7 3/4 | 197 | 12 | 305 | 16 3/4 | 425 | 7 1/4 | 184 |

Figure 22. A.0, B.0 and C.0 cabinet – power exhaust with standard economizer

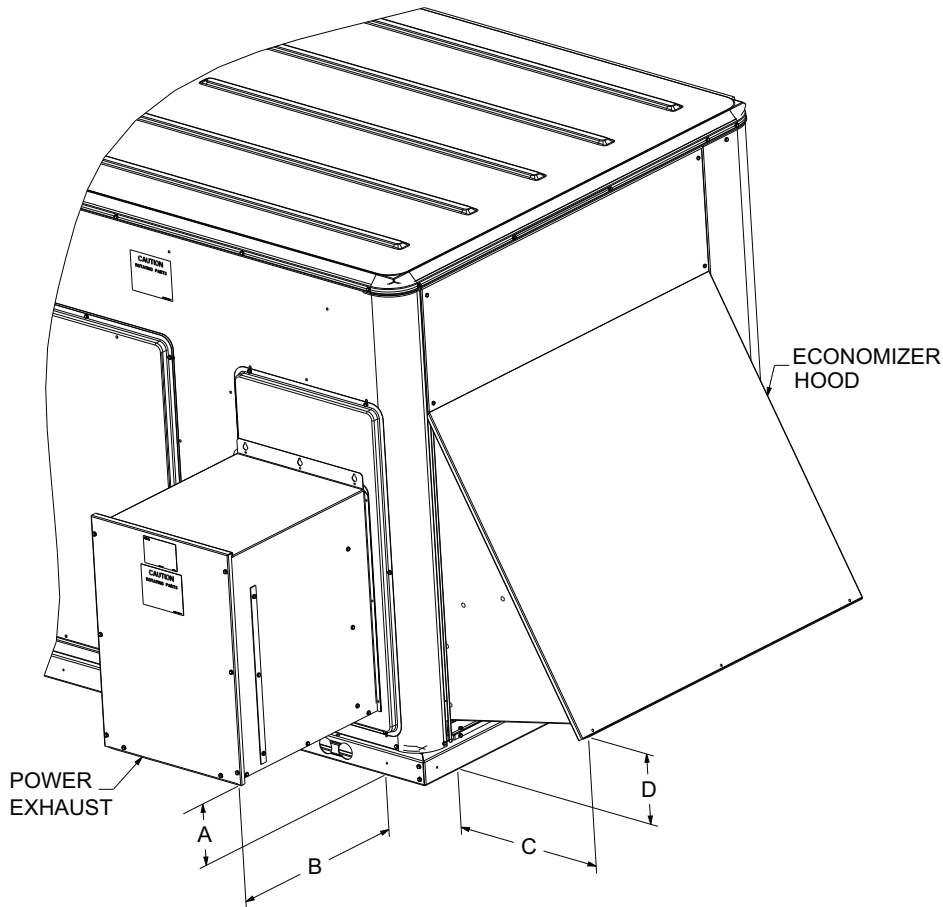

| Cabinet | Dimension | | | | | | | |
|-------------|-----------|-----|--------|-----|--------|-----|-------|-----|
| | A | | B | | C | | D | |
| | inch | mm | inch | mm | inch | mm | inch | mm |
| A.0 | 6 1/4 | 159 | 16 3/4 | 425 | 12 1/2 | 318 | 6 1/4 | 159 |
| B.0 and C.0 | 6 3/8 | 162 | 20 1/2 | 521 | 16 3/4 | 425 | 7 1/4 | 184 |

Figure 23. A.0, B.0 and C.0 cabinet – power exhaust with low leak economizer

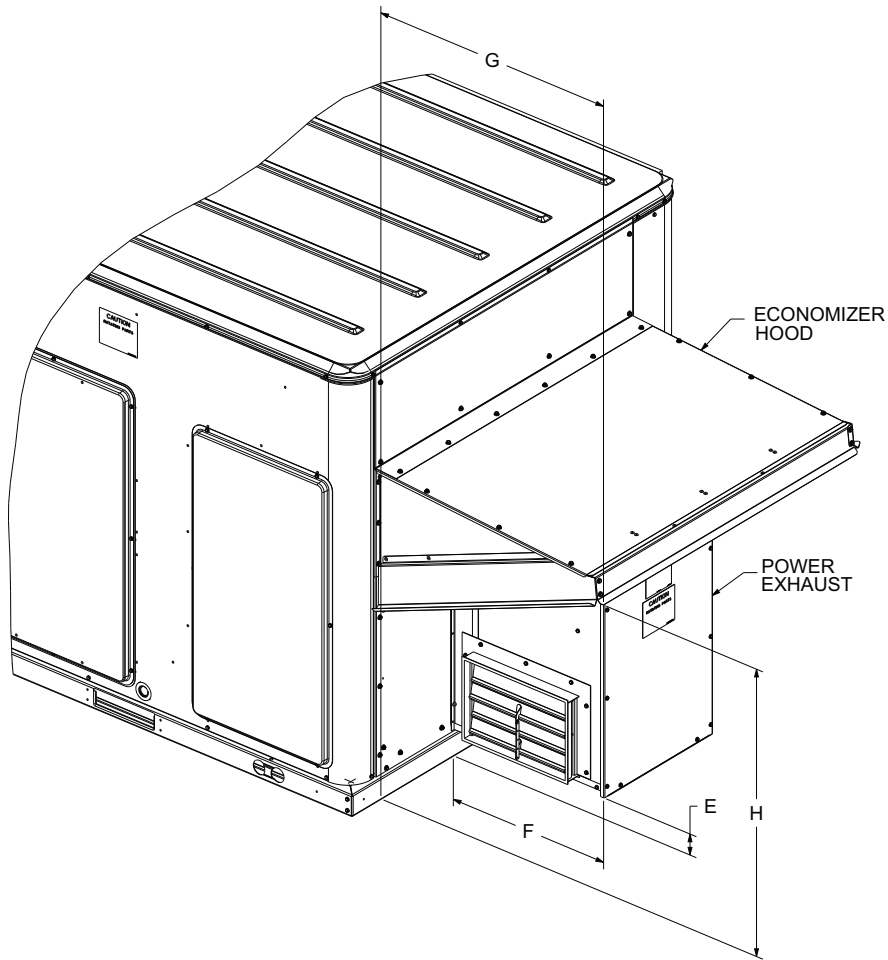

| Cabinet | Dimension | | | | | | | |
|-------------|-----------|----|--------|-----|--------|-----|--------|-----|
| | E | | F | | G | | H | |
| | inch | mm | inch | mm | inch | mm | inch | mm |
| A.0 | 2 1/2 | 64 | 16 | 406 | 19 3/4 | 502 | 27 | 686 |
| B.0 and C.0 | 2 1/2 | 64 | 19 3/4 | 502 | 29 1/4 | 743 | 33 1/2 | 852 |



Dimensions and Weights

Figure 24. D.0 and D.1 cabinets

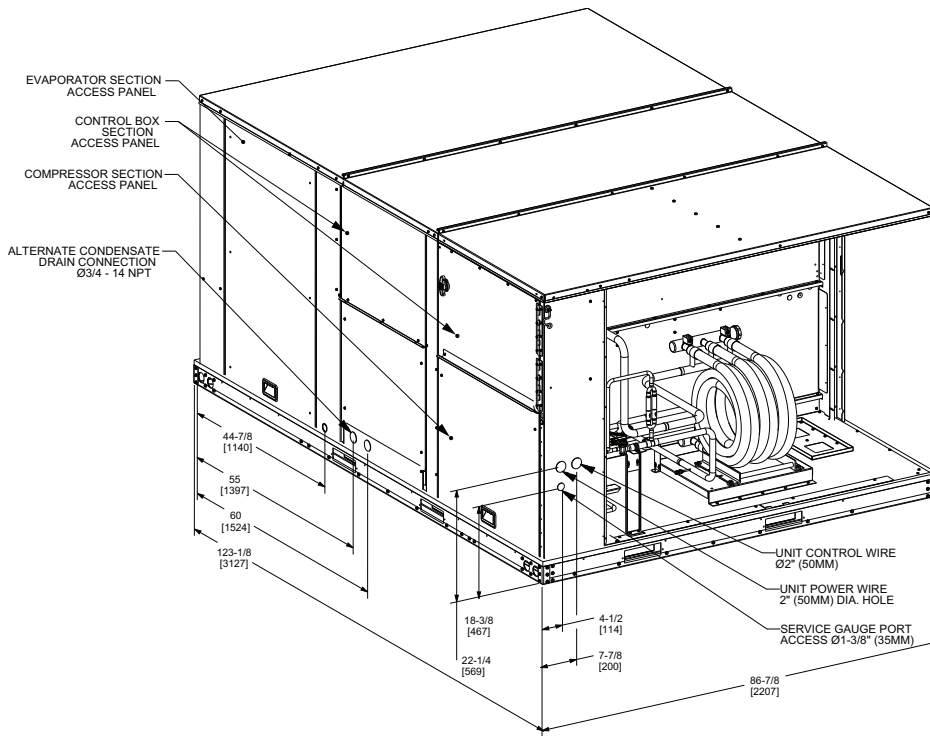

Figure 25. D.0 and D.1 cabinets – downflow airflow supply/return, through-the-base utilities

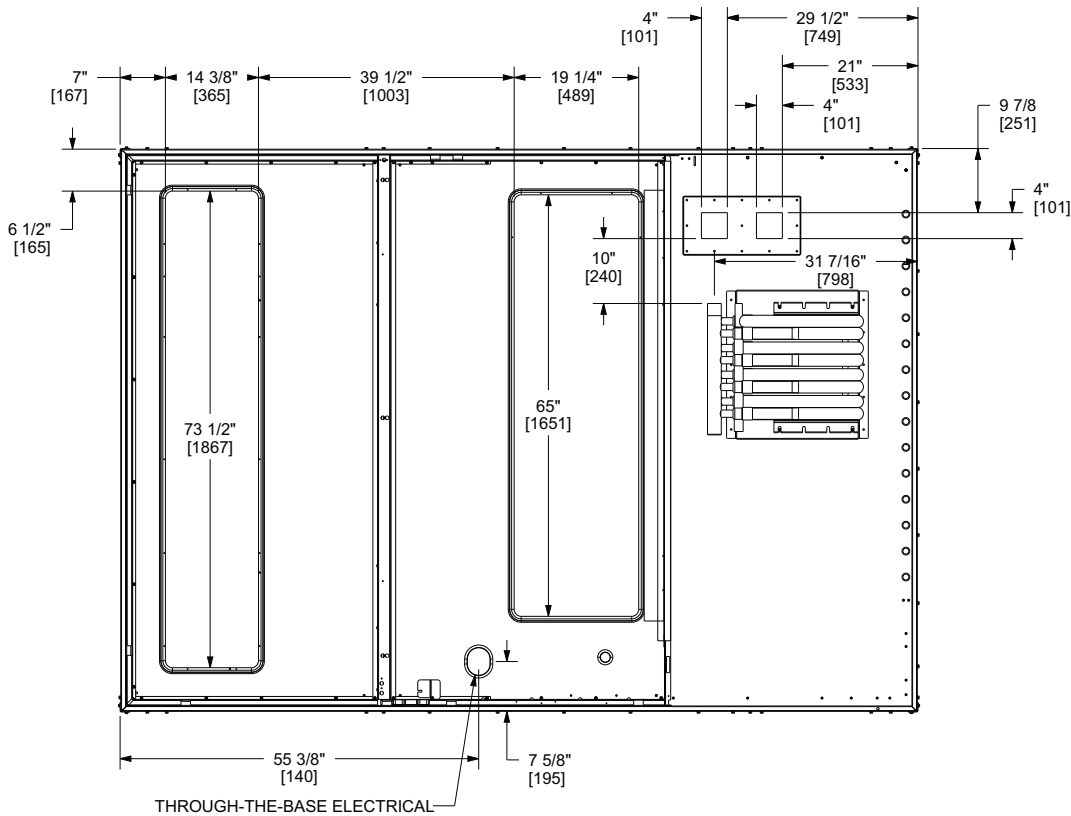

Figure 26. D.0 and D.1 cabinets – horizontal airflow supply/return

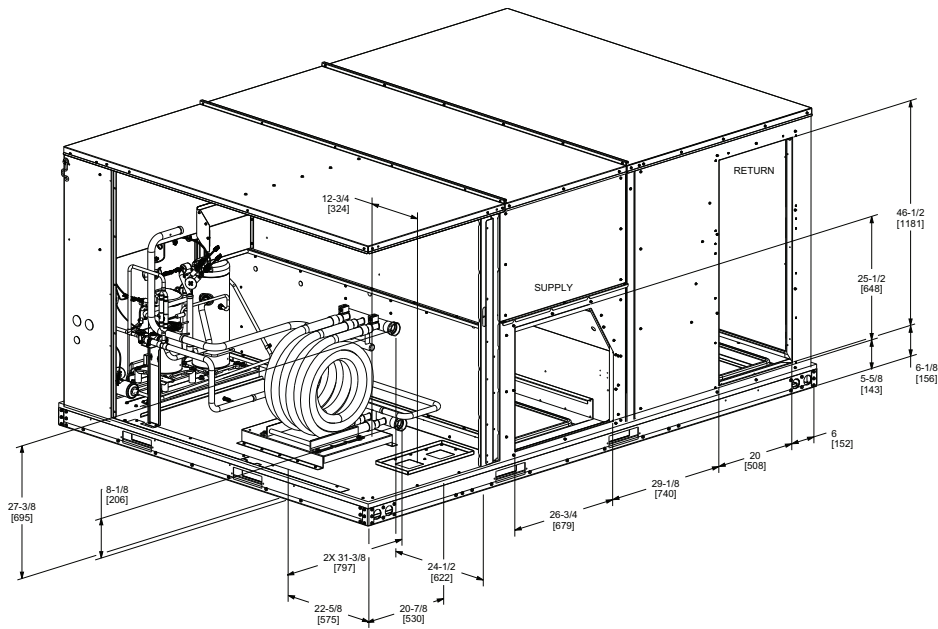
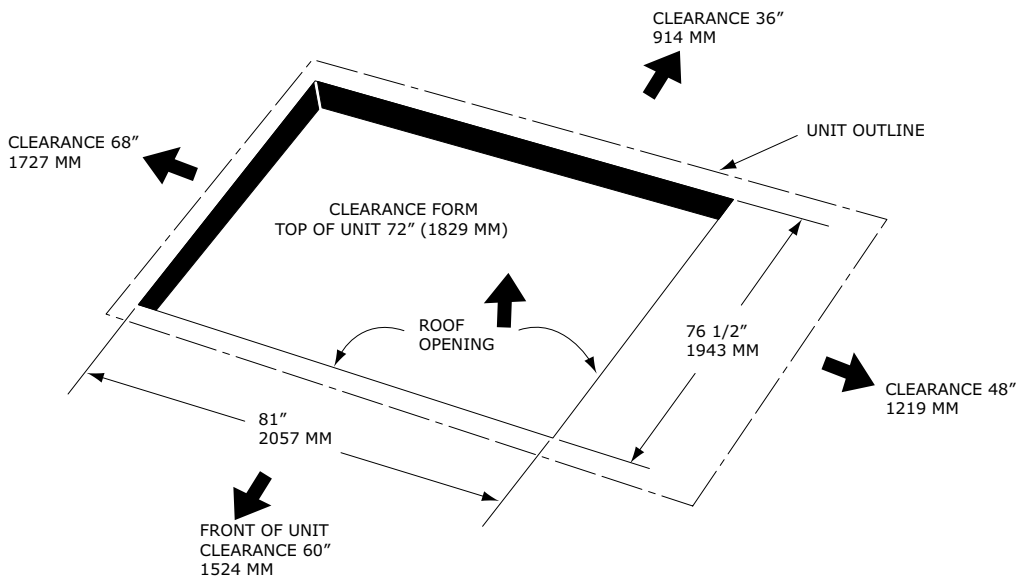

Figure 27. D.0 and D.1 cabinets – unit clearance and roof opening



Dimensions and Weights

Figure 28. D.0 and D.1 cabinets – roof curb

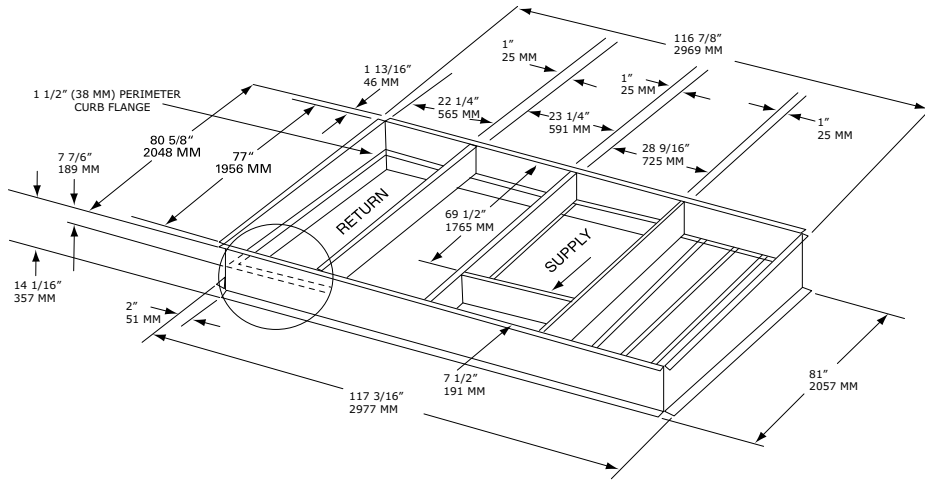

Figure 29. D.0 and D.1 cabinets – swing diameter for hinged door(s) option

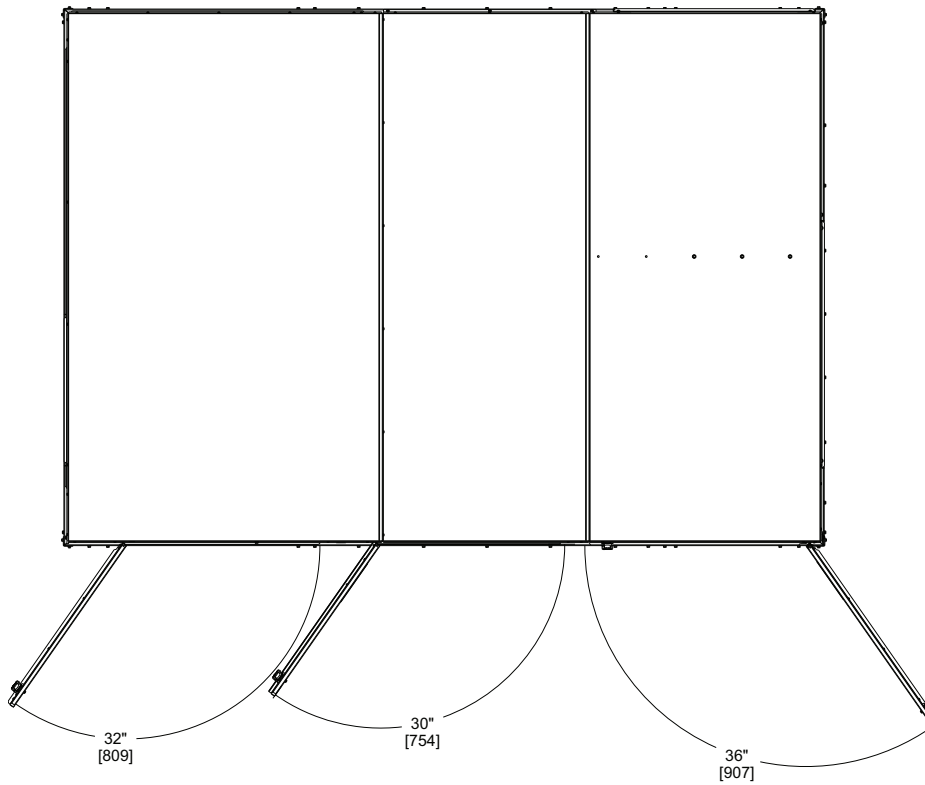
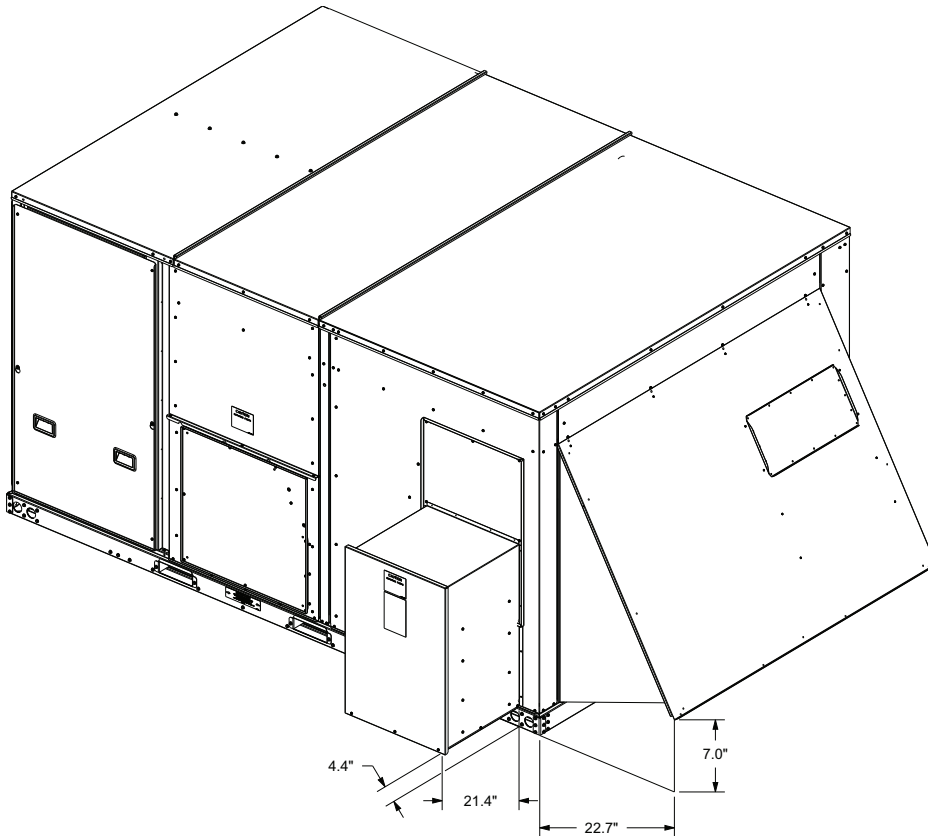

Figure 30. D.0 and D.1 cabinets – power exhaust

Clearances

illustrates the minimum operating and service clearances for either a single or multiple unit installation. These

clearances are the minimum distances necessary to assure adequate serviceability, cataloged unit capacity, and peak operating efficiency.

Weights

Table 5. Model weights, corner weights (lbs) and center of gravity dimensions (in.)

| Model | Width (inch) | Depth (inch) | Height (inch) | Weight (lb) ^(a) | Shipping Weight (lb) | Corner Weights | | | | Center of Gravity | | Water In/Out NPTI (inch) |
|--------|--------------|--------------|---------------|----------------------------|----------------------|----------------|-----|-----|-----|-------------------|----------|--------------------------|
| | | | | | | A | B | C | D | X (inch) | Y (inch) | |
| GSK036 | 69.9 | 44.3 | 46.9 | 707 | 784 | 206 | 157 | 126 | 218 | 30 | 20 | 1.00 NPTI |
| GSK048 | 69.9 | 44.3 | 46.9 | 747 | 824 | 216 | 162 | 125 | 244 | 29 | 20 | |
| GSK060 | 69.9 | 44.3 | 46.9 | 768 | 845 | 223 | 167 | 130 | 248 | 29 | 20 | |
| GSK072 | 88.6 | 53.3 | 46.9 | 903 | 995 | 248 | 230 | 210 | 215 | 20 | 42 | |
| GSK090 | 88.6 | 53.3 | 46.9 | 911 | 1014 | 250 | 231 | 211 | 219 | 25 | 42 | |
| GSK102 | 88.6 | 53.3 | 46.9 | 966 | 1063 | 263 | 236 | 211 | 256 | 25 | 42 | |
| GSK120 | 99.6 | 63.1 | 50.9 | 1259 | 1453 | 363 | 380 | 249 | 267 | 30 | 48 | |
| GSK150 | 123.0 | 87.0 | 59.0 | 1969 | 2219 | 675 | 370 | 429 | 495 | 50 | 70 | 1.50 NPTI |
| GSK180 | 123.0 | 87.0 | 59.0 | 1969 | 2219 | 675 | 370 | 429 | 495 | 50 | 70 | |
| GSK210 | 123.0 | 87.0 | 59.0 | 1969 | 2219 | 675 | 370 | 429 | 495 | 50 | 70 | |
| GSK240 | 123.0 | 87.0 | 66.0 | 2210 | 2460 | 680 | 550 | 528 | 537 | 50 | 71 | 2.00 NPTI |
| GSK300 | 123.0 | 87.0 | 66.0 | 2210 | 2460 | 680 | 550 | 528 | 537 | 50 | 71 | |

^(a) Weights are approximate. Weights do not include additional factory or field installed options/accessories. For option/accessory additional weights to be added to unit weight, reference the following table.

Figure 31. Center of gravity

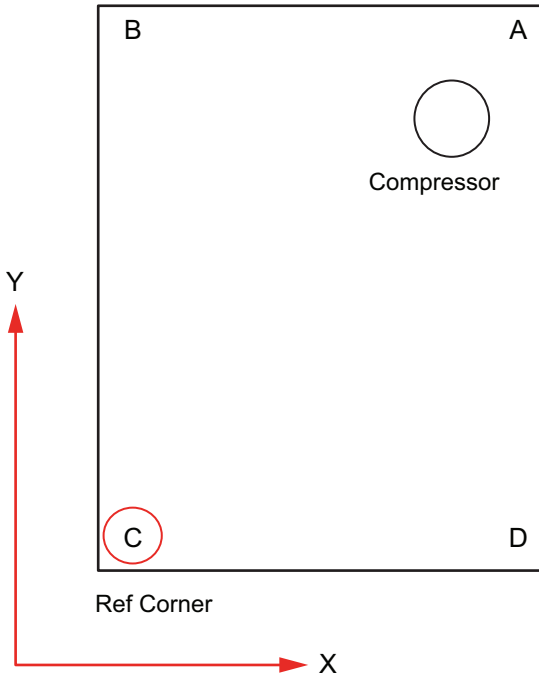

Note: Corner weights and center of gravity do not include accessories.

Table 6. Factory installed options (FIOPS)/accessory net weights (lb)

| Accessory | GSK036-060 | GSK072-102 | GSK120 | GSK150-210 | GSK240-300 |
|----------------------------------|------------|------------|--------|------------|------------|
| Barometric Relief | 7 | 10 | 10 | 40 | 40 |
| Economizer | 26 | 36 | 36 | 91 | 91 |
| Electric Heaters | 15 | 44 | 50 | 75 | 75 |
| Hinged Doors | 10 | 12 | 12 | 20 | 30 |
| Low Leak Economizer - Downflow | 79 | 91 | 91 | 150 | 150 |
| Low Leak Economizer - Horizontal | 130 | 186 | 186 | 180 | 180 |
| Manual Outside Air Damper | 16 | 26 | 26 | 15 | 15 |
| Motorized Outside Air Damper | 20 | 30 | 30 | 82 | 82 |
| Oversized Motor | 5 | 14 | 14 | 30 | 30 |
| Powered Convenience Outlet | 38 | 38 | 50 | 50 | 50 |
| Powered Exhaust | 40 | 80 | 80 | 110 | 110 |
| Reheat Coil | 21 | 16 | 20 | 100 | 100 |
| Roof Curb | 61 | 105 | 111 | 235 | 235 |
| Smoke Detector, Supply | — | 5 | 5 | 5 | 5 |
| Smoke Detector, Return | 7 | 7 | 7 | 5 | 5 |
| Through-the-Base Electrical | 8 | 13 | 13 | 10 | 10 |
| Unit Mounted Circuit Breaker | 5 | 10 | 10 | 10 | 10 |
| Unit Mounted Disconnect | 5 | 5 | 5 | 10 | 10 |

Notes:

1. Weights for options not listed are less than 5 pounds.
2. Net weight should be added to unit weight when ordering factory-installed accessories.
3. Weights are approximate.

Lifting and Rigging

⚠ WARNING

Heavy Object!

Failure to follow instructions below could result in unit dropping which could result in death or serious injury, and equipment or property-only damage.

Ensure that all the lifting equipment used is properly rated for the weight of the unit being lifted. Each of the cables (chains or slings), hooks, and shackles used to lift the unit must be capable of supporting the entire weight of the unit. Lifting cables (chains or slings) may not be of the same length. Adjust as necessary for even unit lift.

⚠ WARNING

Improper Unit Lift!

Failure to properly lift unit in a LEVEL position could result in unit dropping and possibly crushing operator/technician which could result in death or serious injury, and equipment or property-only damage.

Test lift unit approximately 24 inches (61 cm) to verify proper center of gravity lift point. To avoid dropping of unit, reposition lifting point if unit is not level.



Dimensions and Weights

Figure 32. Rigging and center of gravity — 3 to 25 tons

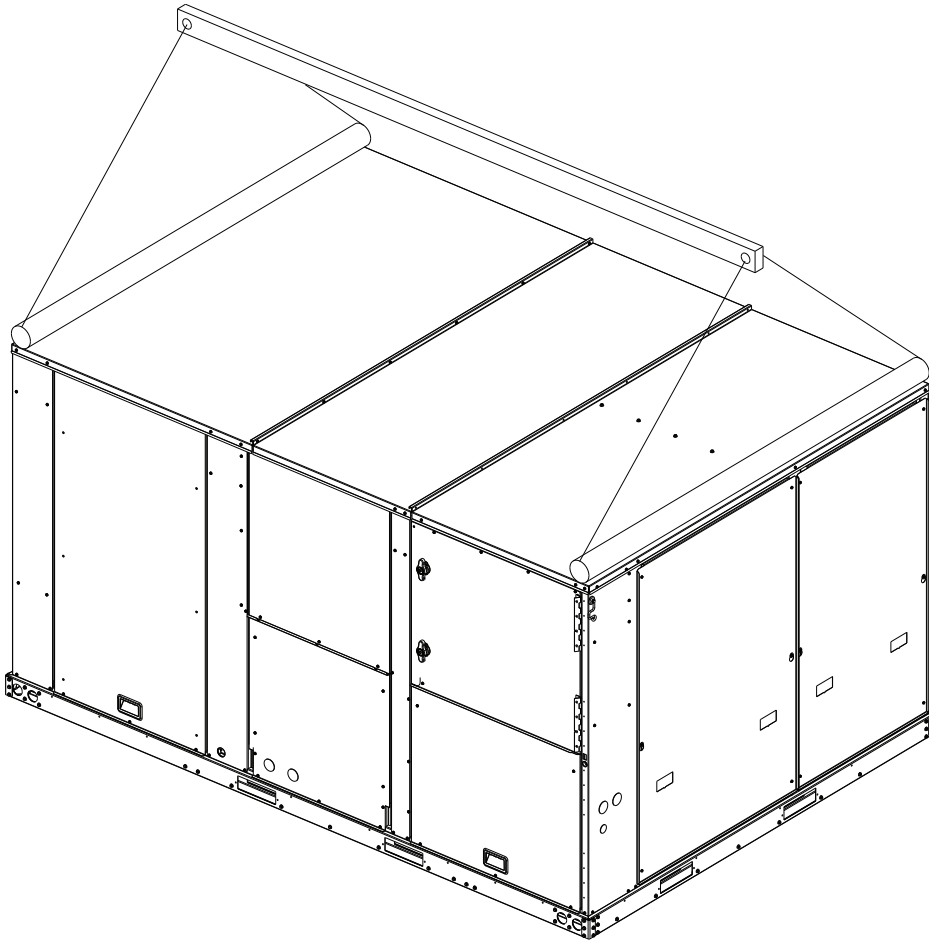



Installation

⚠ WARNING

Heavy Object!

Failure to follow instructions below could result in unit dropping which could result in death or serious injury, and equipment or property-only damage. Ensure that all the lifting equipment used is properly rated for the weight of the unit being lifted. Each of the cables (chains or slings), hooks, and shackles used to lift the unit must be capable of supporting the entire weight of the unit. Lifting cables (chains or slings) may not be of the same length. Adjust as necessary for even unit lift.

NOTICE

Roof Damage!

System contains oil and refrigerant under high pressure. Roofs should be protected from exposure to oils and refrigerant in the system. If rooftop is not protected, damage to the roof may occur.

Important: Refer to local building codes for proper installation. All installation must comply with local building codes.

Horizontal Units

If the unit is installed at ground level, elevate it above the snow line. Provide concrete footings at each support location with a “full perimeter” support structure or a slab foundation for support. Refer to the weights information in

the Dimensions and Weights chapter for the unit’s operating and point loading weights when constructing a footing foundation.

If anchoring is required, anchor the unit to the slab using hold down bolts or isolators. Isolators should be installed to minimize the transmission of vibrations into the building.

⚠ WARNING

Risk of Roof Collapsing!

Failure to ensure proper structural roof support could cause the roof to collapse, which could result in death or serious injury and property damage.

Confirm with a structural engineer that the roof structure is strong enough to support the combined weight of the roofcurb, the unit, and any accessories.

For rooftop applications, ensure the roof is strong enough to support the combined unit and support structural weight. Refer to maximum unit and corner weights (center of gravity) dimensions in the Weights section in Dimensional Data topic for the unit operating weights. If anchoring is required, anchor the unit to the roof with hold-down bolts or isolators.

Check with a roofing contractor for proper waterproofing procedures.

Ductwork

Supply and return air openings as viewed from the rear of the unit are shown in the following drawings.

Figure 33. 3 to 5 tons standard efficiency – horizontal airflow supply/return

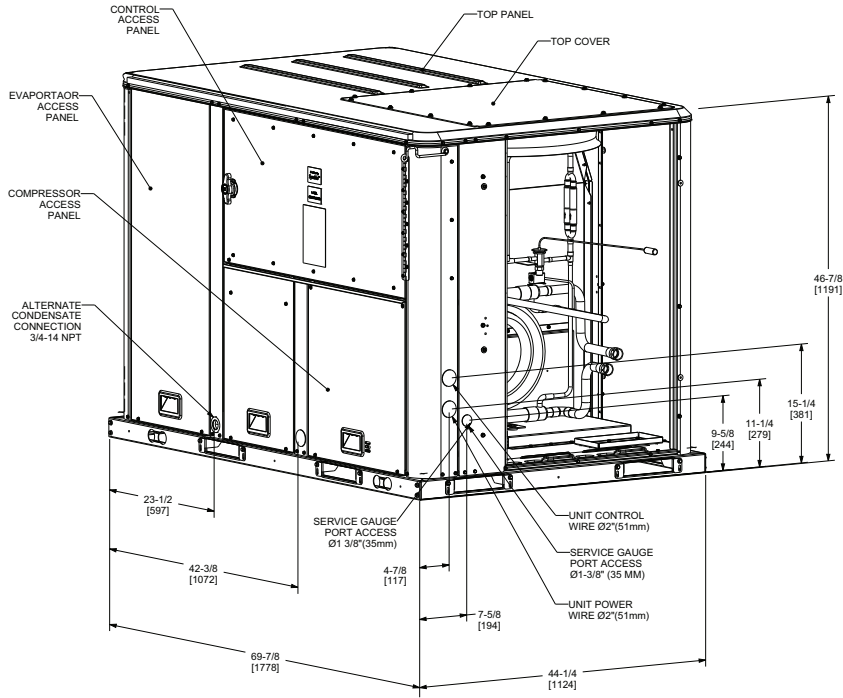

Figure 34. 6 to 8.5 tons standard efficiency – horizontal airflow supply/return

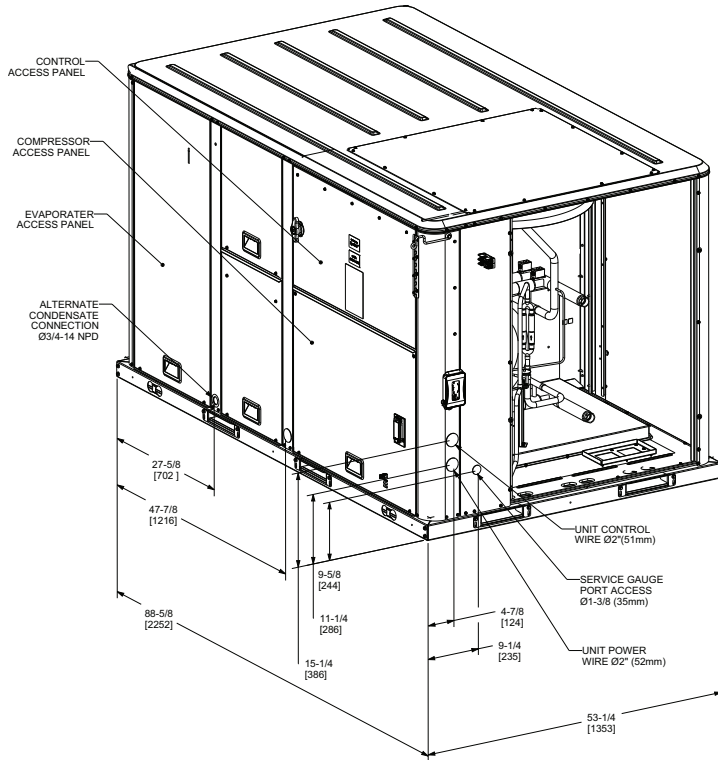

Figure 35. 10 tons standard efficiency – horizontal airflow supply/return

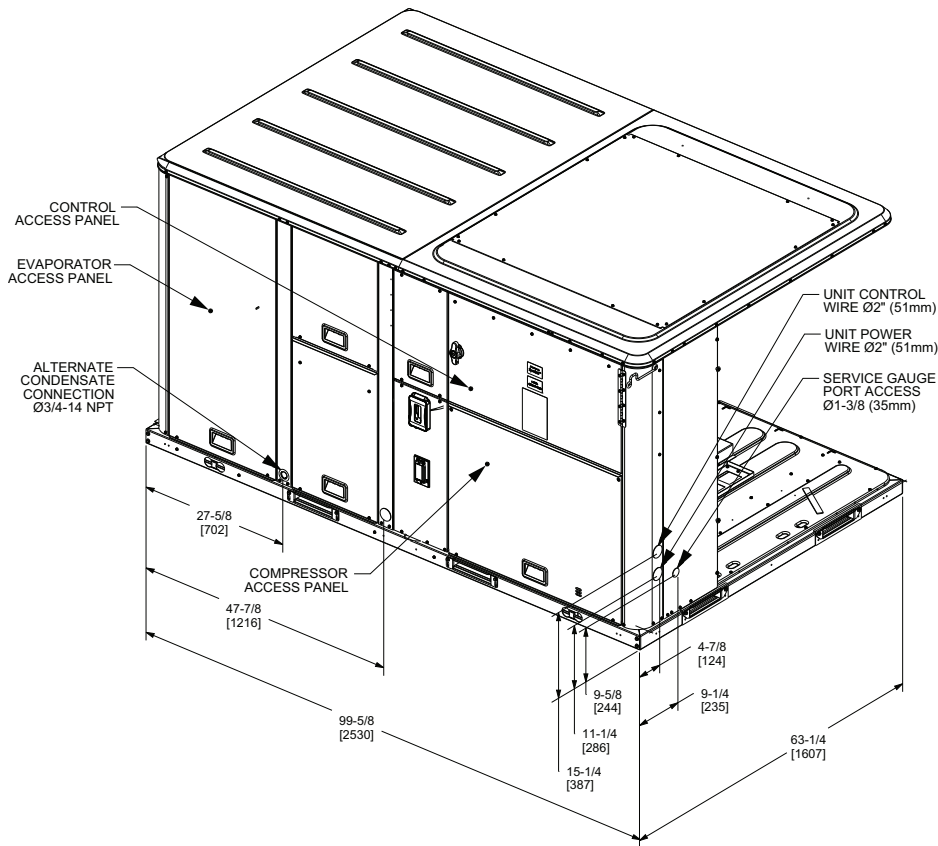
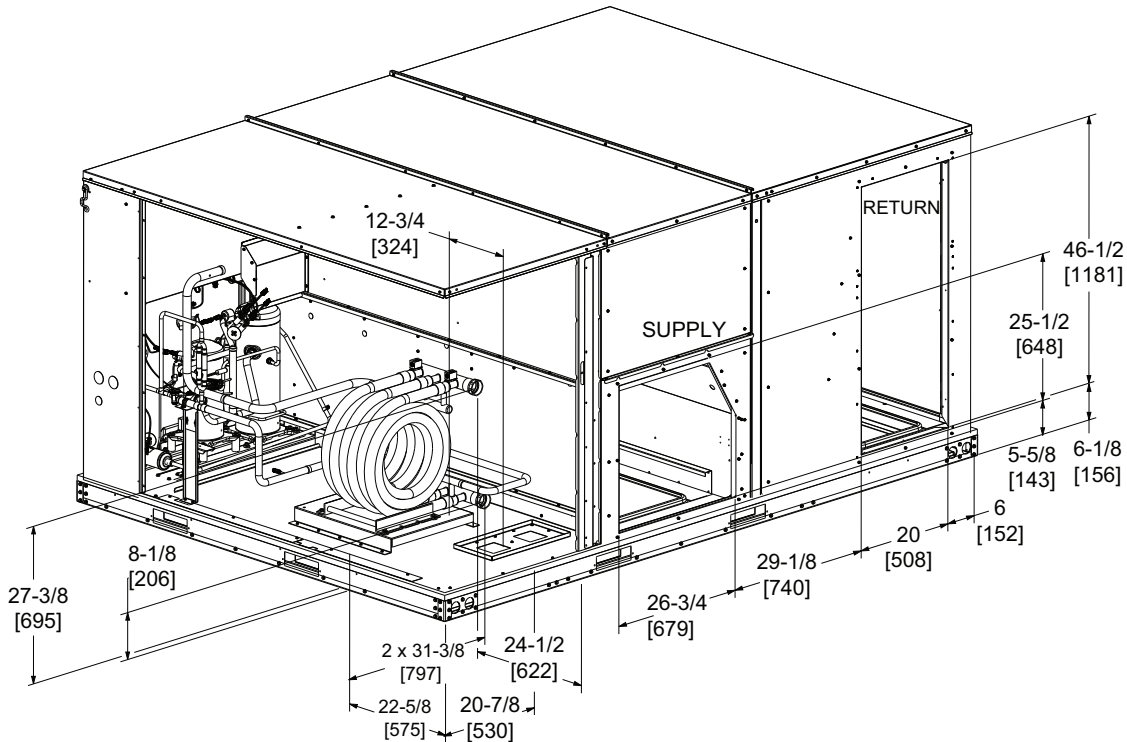

Figure 36. 12.5 to 25 tons standard efficiency – horizontal airflow supply/return





Installation

Supply and return air openings as viewed from a downflow configuration are shown in the following drawings.

Elbows with turning vanes or splitters are recommended to minimize air noise due to turbulence and to reduce static pressure.

When attaching the ductwork to the unit, provide a water tight flexible connector at the unit to prevent operating sounds from transmitting through the ductwork.

All outdoor ductwork between the unit and the structure should be weather proofed after installation is completed.

Figure 37. 3 to 5 tons standard efficiency – downflow airflow supply/return, through-the-base utilities

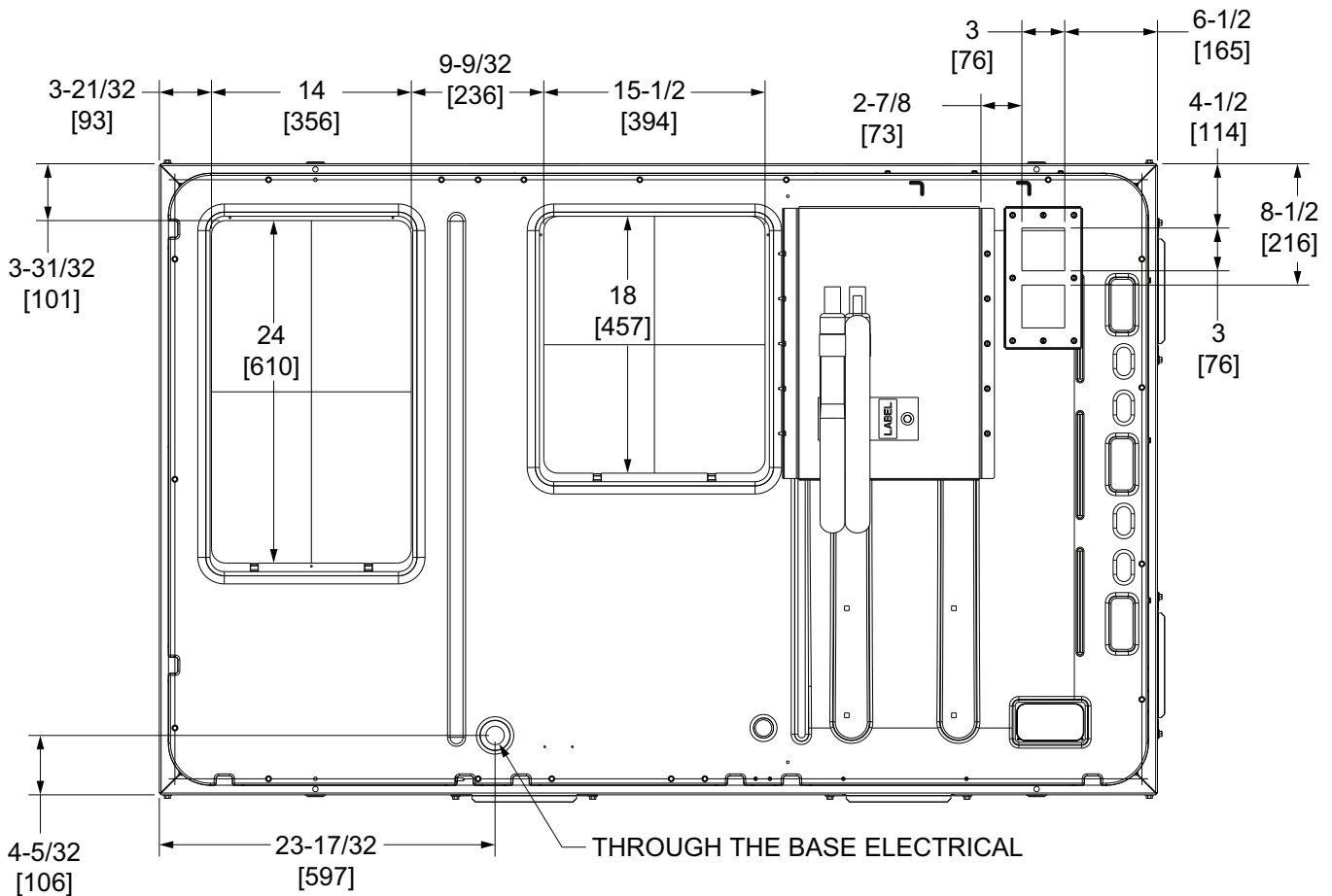

Figure 38. 6 to 10 tons standard efficiency – downflow airflow supply/return, through-the-base utilities

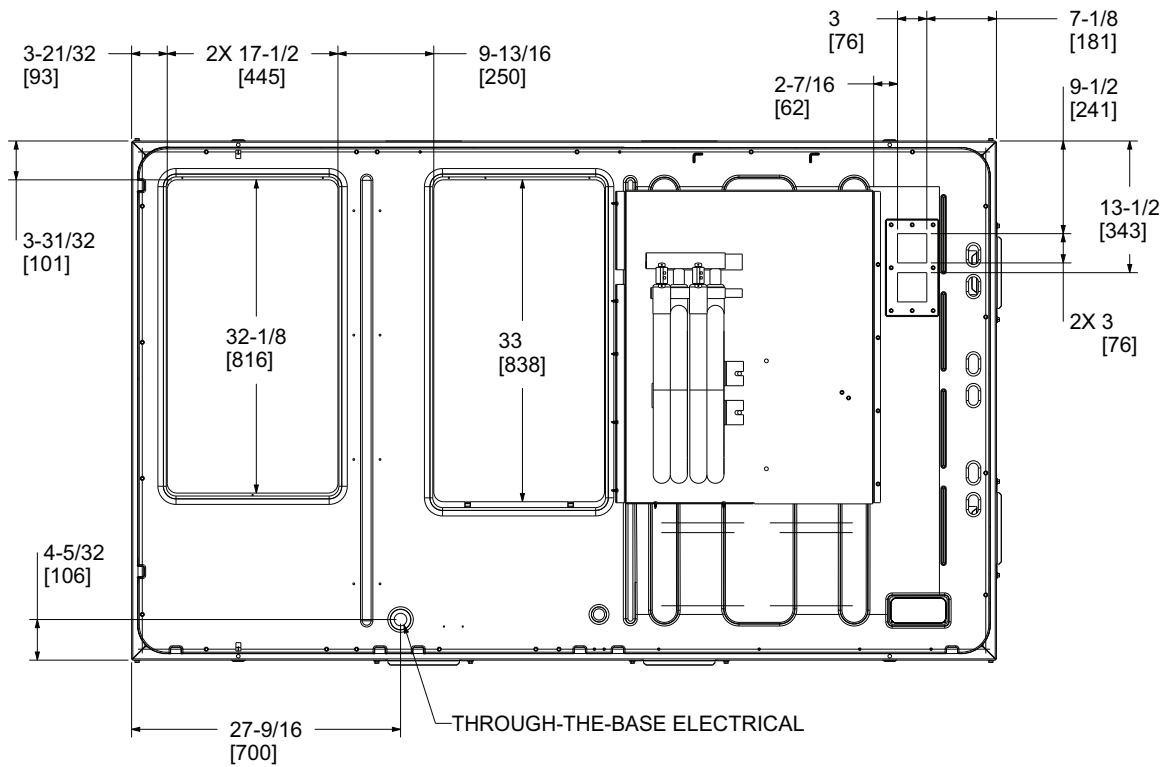
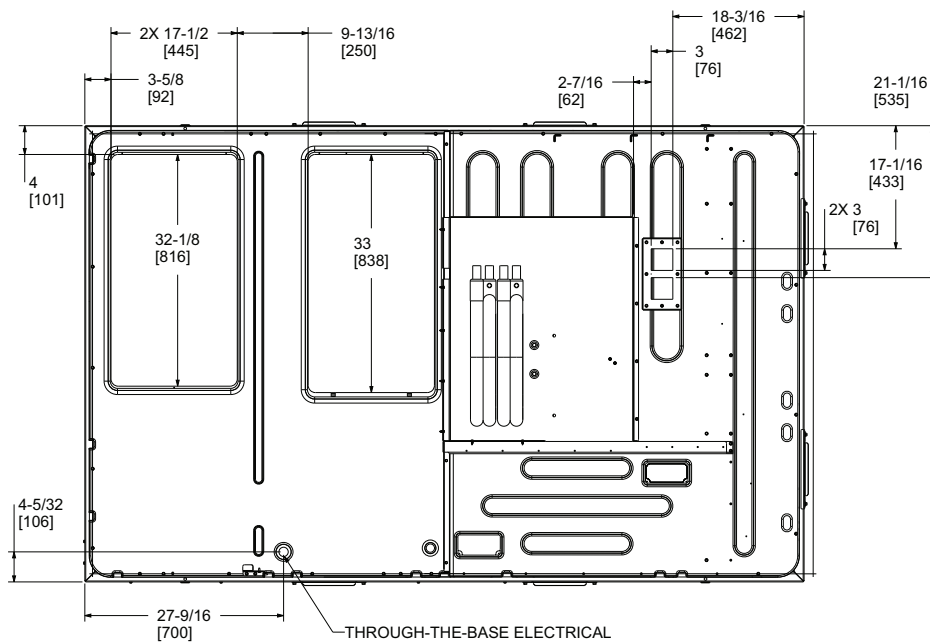

Figure 39. 10 tons standard efficiency – downflow airflow supply/return, through-the-base utilities





Installation

Figure 40. 12.5 to 25 tons standard efficiency – downflow airflow supply/return, through-the-base utilities

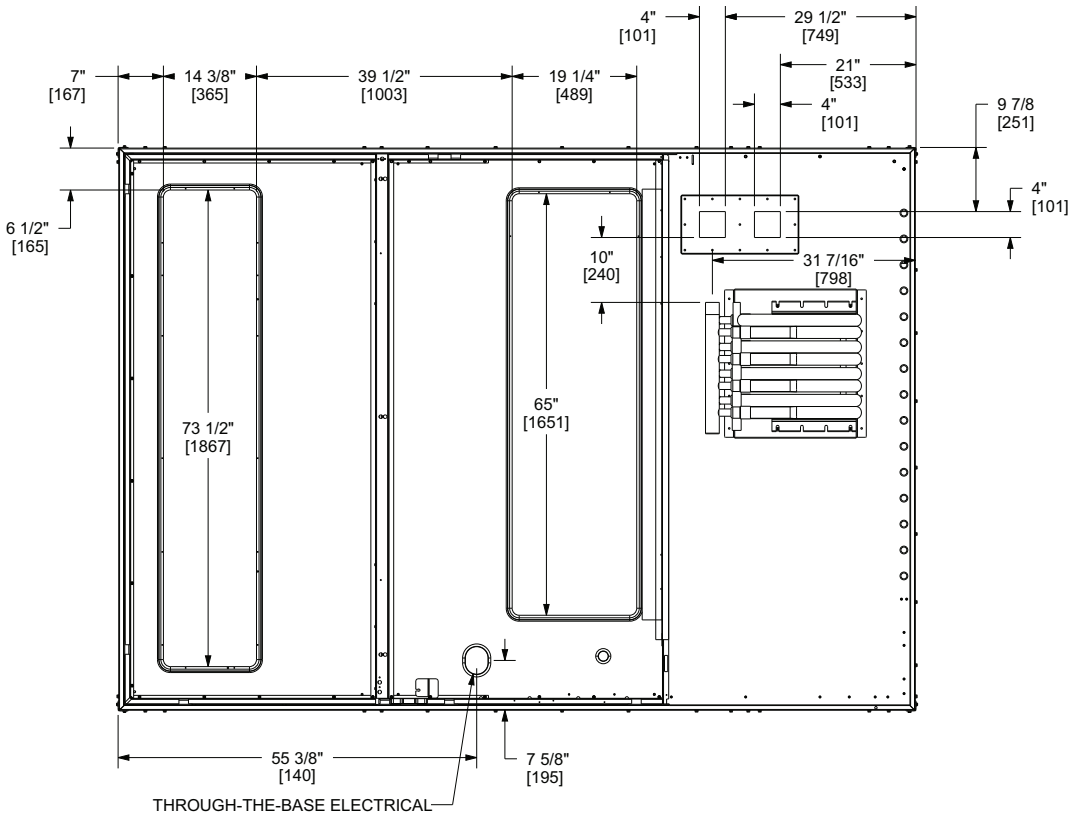

Note: No minimum clearance is required from duct to combustible surfaces.

Roof Curb

Downflow

The roof curbs for these units consists of a “full perimeter” enclosure to support the unit just inside of the unit base rail.

Before installing any roof curb, verify:

- It is the correct curb for the unit.
- The includes the necessary gaskets and hardware.
- The purposed installation location provides the required clearance for proper operation.
- Insure that the curb is level and square. The top surface of the curb must be true to assure an adequate curb-to unit seal.

⚠ WARNING

Combustible Materials!

Failure to maintain proper clearance between the unit and combustible materials could cause a fire which could result in death, serious injury, or property damage.

Refer to unit nameplate and installation instructions for proper clearances.

Verify that appropriate materials were used in the construction of roof and ductwork. Combustible materials should not be used in the construction of ductwork or roof curb that is in close proximity to heater elements or any hot surface. Any combustible material on the inside of the unit base should be removed and replaced with appropriate material.

Step-by-step curb assembly and installation instructions ship with each accessory roof curb kit. Follow the instructions carefully to assure proper fit-up when the unit is set into place.

Note: To assure proper condensate flow during operation, the unit (and curb) must be level.

If the unit is elevated, a field constructed catwalk around the unit is strongly recommended to provide easy access for unit maintenance and service.

Recommendations for installing the Supply Air and Return Air ductwork joining the roof curb are included in the curb instruction booklet. Curb ductwork must be fabricated and installed by the installing contractor before the unit is set into place.

Note: For sound consideration, cut only the holes in the roof deck for the ductwork penetrations. Do not cut out the entire roof deck within the curb perimeter.

If a Curb Accessory Kit is not used:

- The ductwork can be attached directly to the factory-provided flanges around the unit’s supply and return air

openings. Be sure to use flexible duct connections at the unit.

- For “built-up” curbs supplied by others, gaskets must be installed around the curb perimeter flange and the supply and return air opening flanges.

Rigging

⚠ WARNING

Heavy Object!

Failure to follow instructions below could result in unit dropping which could result in death or serious injury, and equipment or property-only damage. Ensure that all the lifting equipment used is properly rated for the weight of the unit being lifted. Each of the cables (chains or slings), hooks, and shackles used to lift the unit must be capable of supporting the entire weight of the unit. Lifting cables (chains or slings) may not be of the same length. Adjust as necessary for even unit lift.

See Dimensional Data chapter for rigging illustration and center-of-gravity information. Refer to the typical unit operating weights table before proceeding.

1. Confirm unit does not need additional moves by fork lift.
2. For 12.5 to 25 ton units, prepare unit for rigging by removing the front and end base rail bumper protection.

Note: For unit protection, the top crate should remain in place during lifting. If it must be removed prior to lifting, protect unit from damage. Top crate must be removed prior to operation.

⚠ WARNING

Improper Unit Lift!

Failure to properly lift unit in a LEVEL position could result in unit dropping and possibly crushing operator/technician which could result in death or serious injury, and equipment or property-only damage.

Test lift unit approximately 24 inches (61 cm) to verify proper center of gravity lift point. To avoid dropping of unit, reposition lifting point if unit is not level.

3. Rig the unit as shown in the weights section. Attach adequate strength lifting slings to all four lifting brackets in the unit base rail. Do not use cables, chains, or slings except as shown.
4. Install a lifting bar, as shown in the Dimensions Data chapter, to protect the unit and to facilitate a uniform lift. The minimum distance between the lifting hook and the top of the unit should be 7 feet.
5. Test-lift the unit to ensure it is properly rigged and balanced, make any necessary rigging adjustments.

Figure 41. Fork pockets — A.0 and B.0 cabinets

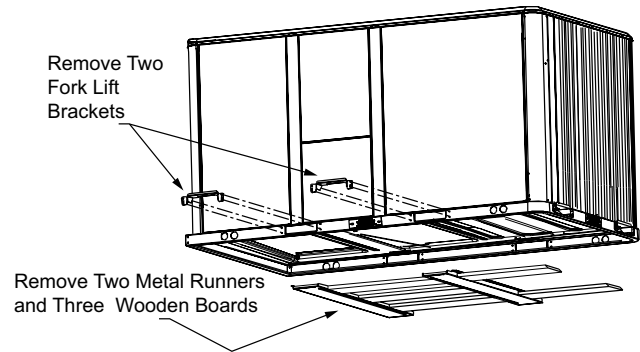

Figure 42. Fork pockets — C.0 cabinet

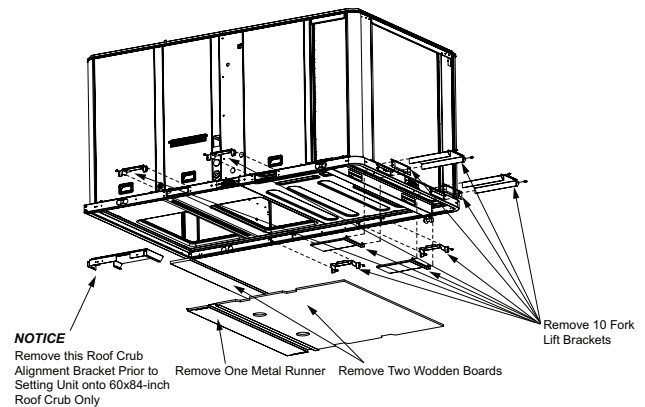
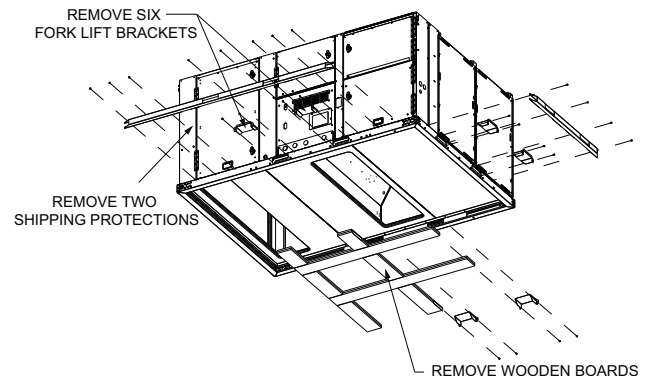

Figure 43. Fork pockets — D.0 and D.1 cabinets



6. Lift the unit enough to allow the removal of base fork pocket protection components as shown in the following figures.
7. Downflow units; align the base rail of the unit with the curb rail while lowering the unit onto the curb. Make sure that the gasket on the curb is not damaged while positioning the unit.

General Unit Requirements

The checklist listed below is a summary of the steps required to successfully install a commercial unit. This checklist is intended to acquaint the installing personnel

with what is required in the installation process. It does not replace the detailed instructions called out in the applicable sections of this manual.

- Check the unit for shipping damage and material shortage; file a freight claim and notify appropriate sales representative.
- Verify correct model, options and voltage from unit nameplate.
- Verify that the installation location of the unit will provide the required clearance for proper operation.
- Assemble and install the roof curb (if applicable). Refer to the latest edition of the curb installers guide that ships with each curb kit.
- Fabricate and install ductwork; secure ductwork to curb.
- Install pitch pocket for power supply through building roof. (If applicable)
- Rigging the unit.
- Set the unit onto the curb; check for levelness.
- Ensure unit-to-curb seal is tight and without buckles or cracks.
- Install and connect a condensate drain line to the evaporator drain connection.

Factory Installed Economizer

- Ensure the economizer has been pulled out into the operating position. Refer to the economizer installers guide for proper position and setup.
- Install all access panels.

Return Air Smoke Detector

The factory installed Return Air Smoke Detector is installed in the downflow discharge position for 12.5 to 25 ton units. No additional field setup is required.

If a unit is to be converted to horizontal discharge, for 12.5 to 25 ton units, the following conversion must be performed:

1. If the unit has an economizer, it must be pulled out in the operating position.
2. Remove the 2 screws from the mounting brackets.

Note: Refer to downflow view for screw locations of 12.5 to 25 ton units.

Figure 44. Downflow bracket installation (view from horizontal return duct)

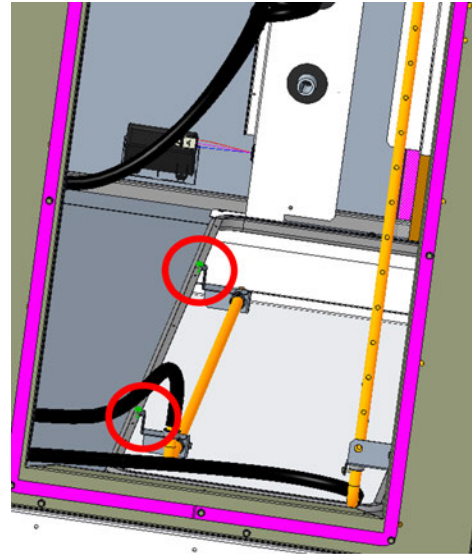

3. Lift the tube and bracket from the downflow duct opening. Rotate the tube and bracket assembly 90 degrees ensuring that the holes on the aluminium sensing tube face away from the unit and face the return air ductwork.

Note: Refer to horizontal views below of the 12.5 to 25 ton units.

Figure 45. Horizontal bracket installation (top view of unit)

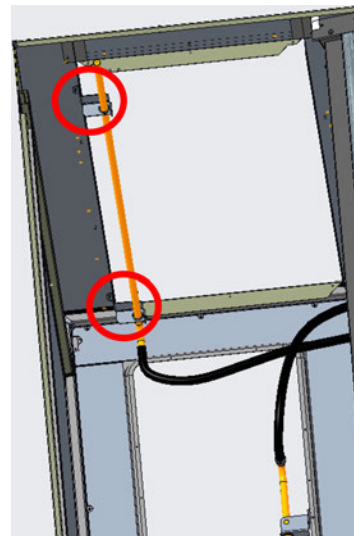

Note: Check to insure that the flexible tubing lies flat on the base pan surface.

4. Slide the top bracket down the aluminium sensing tube.
 - For 12.5 to 25 ton units with standard or low leak economizers, also secure the tube to the top right side of the horizontal opening flange (right side)

when viewed from outside unit facing horizontal supply). See below figure.

Figure 46. Horizontal bracket installation (view from horizontal return duct)

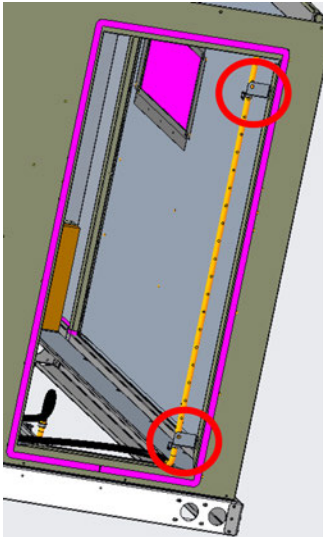

- Using the remaining 2 screws and bracket removed in step 2, secure the bottom bracket.

Air-Fi® Wireless Communication Interface

The factory installed wireless communications interface is installed in the downflow discharge position.

If a unit is to be converted to horizontal discharge, the following conversion must be performed:

- If the unit has an economizer, it must be pulled out in the operating position.
- Remove the screw from the mounting bracket. Refer to downflow view for screw and bracket location.
- Mount the bracket in the horizontal discharge location. Refer to horizontal view for screw and bracket location.

Note: Cable ties must be removed to allow the cable to extend to the horizontal mounting location.

Main Electrical Power Requirements

⚠ WARNING

Hazardous Voltage w/Capacitors!

Failure to disconnect power and discharge capacitors before servicing could result in death or serious injury.

Disconnect all electric power, including remote disconnects and discharge all motor start/run capacitors before servicing. Follow proper lockout/tagout procedures to ensure the power cannot be inadvertently energized. For variable frequency drives or other energy storing components provided by Trane or others, refer to the appropriate manufacturer's literature for allowable waiting periods for discharge of capacitors. Verify with a CAT III or IV voltmeter rated per NFPA 70E that all capacitors have discharged.

⚠ WARNING

Proper Field Wiring and Grounding Required!

Failure to follow code could result in death or serious injury.

All field wiring **MUST** be performed by qualified personnel. Improperly installed and grounded field wiring poses **FIRE** and **ELECTROCUTION** hazards. To avoid these hazards, you **MUST** follow requirements for field wiring installation and grounding as described in **NEC** and your local/state/national electrical codes.

- Verify that the power supply complies with the unit nameplate specifications.
- Inspect all control panel components; tighten any loose connections.
- Connect properly sized and protected power supply wiring to a field-supplied/installed disconnect switch and to the main power terminal block (HTB1) in the unit control panel.
- Install proper grounding wires to an earth ground.

Electric Heat Requirements

- Verify that the power supply complies with the electric heater specifications on the unit and heater nameplate.
- Inspect the heater junction box and control panel; tighten any loose connections.
- Check electric heat circuits for continuity.

Low Voltage Wiring

Mount the indoor thermostat, zone sensor, or programmable zone sensor in accordance with the corresponding thermostat installation instructions. Install



Installation

color-coded, weather-proof, multi-wire cable according to the field wiring instructions.

Note: Refer to thermostat or zone sensor wire installation guide for proper wire gauge.

Condensate Drain Configuration

An evaporator condensate drain connection is provided on each unit. Refer to the ductwork section in the Installation chapter for the appropriate drain location.

A condensate trap must be installed at the unit due to the drain connection being on the “negative pressure” side of the fan. Install the P-Trap using the guidelines in the figure below.

A condensate drain line must be connected to the P-Trap. Pitch the drain lines at least 1/2 inch for every 10 feet of horizontal run to assure proper condensate flow. Do not allow the horizontal run to sag causing a possible double trap condition which could result in condensate backup due to “air lock”.

Figure 47. Condensate trap installation

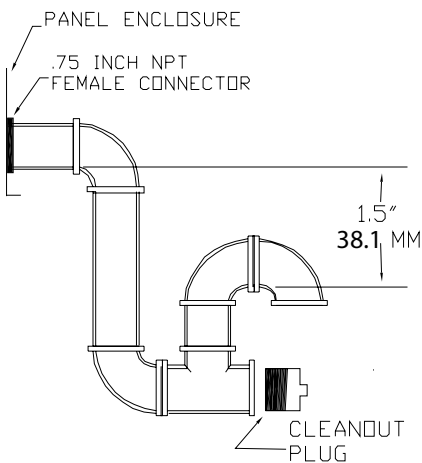

Filter Installation

The quantity of filters is determined by unit size. Access to the filters is obtained by removing the filter access panel.

Note: Do not operate the unit without filters.

Field Installed Power Wiring

⚠ WARNING

Proper Field Wiring and Grounding Required!

Failure to follow code could result in death or serious injury.

All field wiring MUST be performed by qualified personnel. Improperly installed and grounded field wiring poses FIRE and ELECTROCUTION hazards. To avoid these hazards, you MUST follow requirements for field wiring installation and grounding as described in NEC and your local/state/national electrical codes.

An overall dimensional layout for the field installed wiring entrance into the unit is illustrated in the Dimensions and Weights chapter. To ensure that the unit's supply power wiring is properly sized and installed, follow the following guidelines.

Verify that the power supply available is compatible with the unit's nameplate ratings. The available supply power must be within 10% of the rated voltage stamped on the nameplate. Use only copper conductors to connect the power supply to the unit.

NOTICE

Use Copper Conductors Only!

Failure to use copper conductors could result in equipment damage as the equipment was not designed or qualified to accept other types of conductors.

Important: If the unit is not equipped with an optional factory installed non-fused disconnect switch or circuit breaker, a field supplied disconnect switch must be installed at or near the unit in accordance with the National Electrical Code (NEC latest edition).

Main Unit Power

⚠ WARNING

Proper Field Wiring and Grounding Required!

Failure to follow code could result in death or serious injury.

All field wiring MUST be performed by qualified personnel. Improperly installed and grounded field wiring poses FIRE and ELECTROCUTION hazards. To avoid these hazards, you MUST follow requirements for field wiring installation and grounding as described in NEC and your local/state/national electrical codes.

⚠ WARNING

Hazardous Voltage!

Failure to disconnect power before servicing could result in death or serious injury.

Disconnect all electric power, including remote disconnects before servicing. Follow proper lockout/tagout procedures to ensure the power can not be inadvertently energized. Verify that no power is present with a voltmeter.

Standard Wiring

1. Location of the applicable electrical service entrance is illustrated in the Dimensions and Weights chapter. Complete the unit's power wiring connections at HTB1 main power terminal block in unit control panel. Refer to the customer connection diagram that is shipped with the unit for specific termination points.
2. Provide proper grounding for the unit in accordance with local and national codes.

Optional TBUE Wiring (Through-the-Base Electrical Option)

Location of the applicable electrical service is illustrated below. Refer to the customer connection diagram that is shipped with the unit for specific termination points. The termination points, depending on the customer option selected would be a factory mounted non-fused disconnect switch (UDC) or circuit breaker (UCB). If neither a factory mounted non-fused disconnect switch (UDC) or circuit breaker (UCB) was factory mounted, field wiring connections should be terminated in the control box at main panel power terminal block (HTB1).

Provide proper grounding for the unit in accordance with local and national codes.

Notes:

- *Black gasket is shipped from the factory and is located in the literature Ship With bag in the control box. Apply black gasket around conduit plate on all four sides after installation to prevent air leakage from the building entering the electrical enclosures.*
- *Seal any unused unit penetrations and around conduit and wiring at all unit and curb penetrations.*

Field-Installed Control Wiring

⚠ WARNING

Hazardous Voltage!

Failure to disconnect power before servicing could result in death or serious injury.

Disconnect all electric power, including remote disconnects before servicing. Follow proper lockout/tagout procedures to ensure the power can not be inadvertently energized. Verify that no power is present with a voltmeter.

⚠ WARNING

Proper Field Wiring and Grounding Required!

Failure to follow code could result in death or serious injury.

All field wiring **MUST** be performed by qualified personnel. Improperly installed and grounded field wiring poses **FIRE** and **ELECTROCUTION** hazards. To avoid these hazards, you **MUST** follow requirements for field wiring installation and grounding as described in **NEC** and your local/state/national electrical codes.

An overall layout of the various control options available with the required number of conductors for each control device is illustrated in the wiring diagram located on main control box door.

All field wiring must conform to NEC guidelines as well as state and local codes.

Control Power Transformer

The 24 volt control power transformers are to be used only with the accessories called out in this manual.

Transformers rated greater than 50 VA are equipped with internal circuit breakers. If a circuit breaker trips, turn "Off" all power to the unit before attempting to reset it.

⚠ WARNING

Hazardous Voltage!

Failure to disconnect power before servicing could result in death or serious injury.

Disconnect all electric power, including remote disconnects before servicing. Follow proper lockout/tagout procedures to ensure the power can not be inadvertently energized. Verify that no power is present with a voltmeter.

The transformers are located in the control panel. The circuit breaker is located on the right side of the transformer and can be reset by pressing in on the black reset button.

Controls using 24 VAC

Before installing any connecting wiring, refer to the Dimensions and Weights chapter for the electrical access

locations provided on the unit and for AC conductor sizing guidelines, and;

1. Use copper conductors unless otherwise specified.
2. Ensure that the AC control wiring between the controls and the unit's termination point does not exceed 2.5 ohms/conductor for the length of the run

NOTICE

Component Failure!
Resistance in excess of two and a half (2.5) ohms per conductor could result in component failure due to insufficient AC voltage supply.
Do not exceed two and a half (2.5) ohms per conductor for the length of the run.

Note: Be sure to check all loads and conductors for grounds, shorts, and mis-wiring.

3. Do not run the AC low voltage wiring in the same conduit with the high voltage power wiring.
4. Route low voltage wiring per illustrations below.

Figure 48. Low voltage wiring — A.0/B.0 cabinet

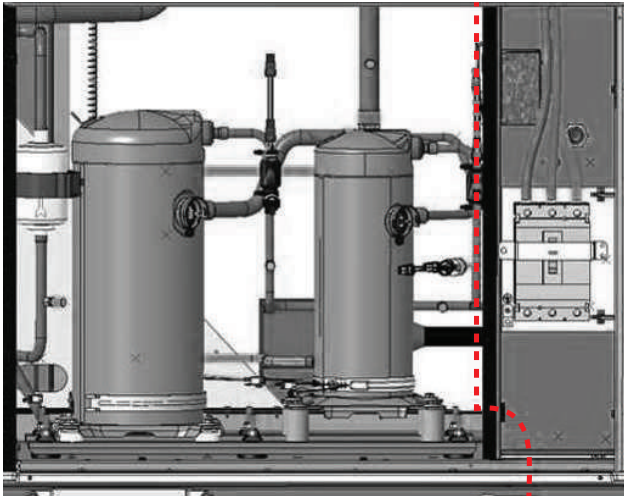

Figure 49. Low voltage wiring — C.0 cabinet

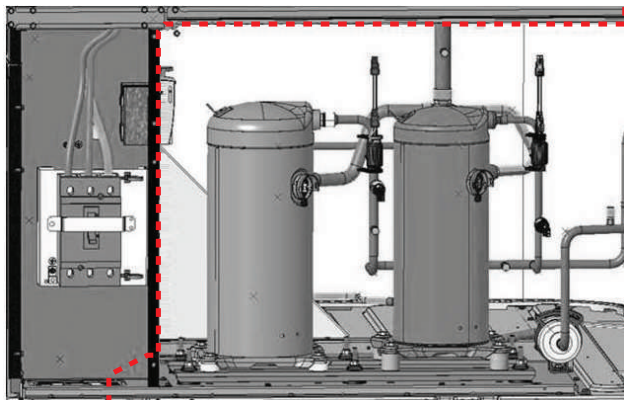

Figure 50. Low voltage wiring — D.0 cabinet

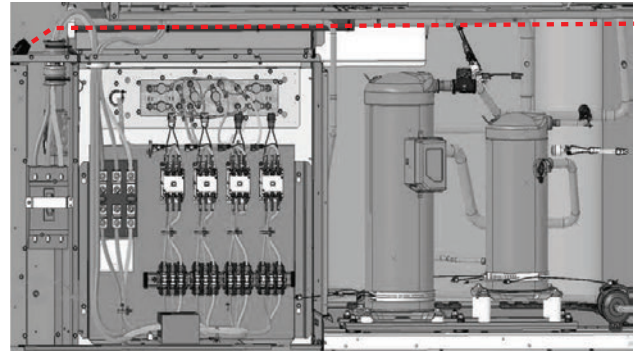

Figure 51. Main control panel low voltage wiring

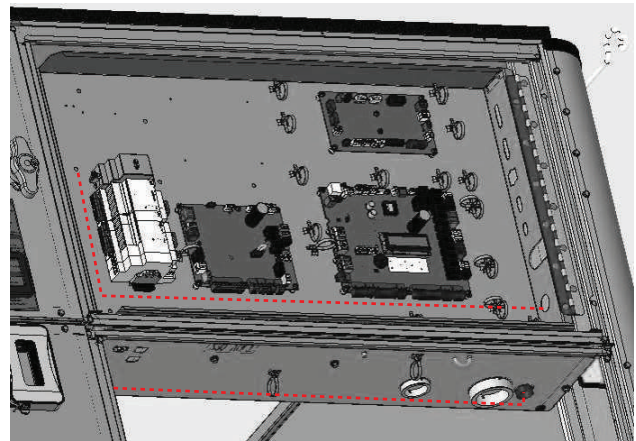

Table 7. Recommended wire lengths

| Wire Size | | Maximum recommended wire length from unit controller to sensor | |
|-----------|-----------------|--|---------|
| AWG | mm ² | Meters | Feet |
| 22 | 0.33 | 0–46 | 0–150 |
| 20 | 0.50 | 47–73 | 151–240 |
| 18 | 0.75 | 74–117 | 241–385 |
| 16 | 1.30 | 118–185 | 386–610 |
| 14 | 2.00 | 186–296 | 611–970 |

Note: The total resistance of these low voltage wires must not exceed 2.5 Ω/conductor. Any resistance greater than 2.5 Ω may cause the control to malfunction due to an excessive voltage drop.

Controls using DC Analog Input/Outputs (Standard Low Voltage Multi conductor Wire)

Before installing any connecting wiring between the unit and components utilizing a DC analog input/output signal, refer to the Dimensions and Weights chapter for the electrical access locations provided on the unit.

- Table 8, p. 51 lists the conductor sizing guidelines that must be followed when interconnecting the DC binary output devices and the system components utilizing a DC analog input/output signal to the unit.

Notes:

- Resistance in excess of 2.5 ohms per conductor can cause deviations in the accuracy of the controls.
 - Ensure that the wiring between controls and the unit's termination point does not exceed two and a half (2.5) ohms/conductor for the length of the run.
- Do not run the electrical wires transporting DC signals in or around conduit housing high voltage wires.

DC Conductors

Table 8. Zone sensor module wiring

| Distance from Unit to Control | Recommended Wire Size |
|-------------------------------|-----------------------|
| 0 - 150 feet | 22 gauge |
| 0 - 45.7 m | 0.33 mm ² |
| 151 - 240 feet | 20 gauge |
| 46 - 73.1 m | 0.50 mm ² |
| 241 -385 feet | 18 gauge |
| 73.5 - 117.3 m | 0.75 mm ² |
| 386 - 610 feet | 16 gauge |
| 117.7 - 185.9 m | 1.3 mm ² |
| 611 - 970 feet | 14 gauge |
| 186.2 - 295.7 m | 0.2 mm ² |

Note: See Symbio™ 700 unit controls schematic, 1213-4538, for controls wiring.

Space Temperature Averaging

Space temperature averaging is accomplished by wiring a number of remote sensors in a series/parallel circuit. Using the BAYSENS016* or BAYSENS077*, at least four sensors are required to accomplish space temperature averaging.

- Example #1 illustrates two series circuits with two sensors in each circuit wired in parallel. The square of any number of remote sensors is required.
- Example #2 illustrates three sensors squared in a series/parallel circuit. Using BAYSENS077*, two sensors are required to accomplish space temperature averaging.
- Example #3 illustrates the circuit required for this sensor. lists the temperature versus resistance coefficient for all sensors.

Figure 52. Examples

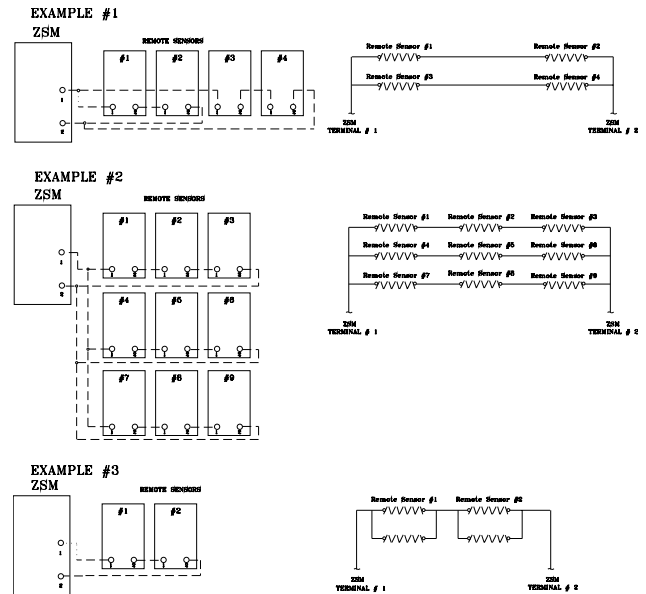

Note: Wiring pin numbers are for reference only. There are multiple smoke detector systems that could have differently numbered pins. For correct wiring details, please refer to the specific smoke detector literature that accompanied this unit.

Table 9. Temperature vs. resistance

| Temperature | | Nominal Resistance (kOhms) |
|-------------|------------|----------------------------|
| Degrees °F | Degrees °C | |
| -20 | -28.9 | 170.1 |
| -15 | -26.1 | 143.5 |
| -10 | -23.3 | 121.4 |
| -5 | -20.6 | 103.0 |
| 0 | -17.8 | 87.56 |
| 5 | -15.0 | 74.65 |
| 10 | -12.2 | 63.80 |
| 15 | -9.4 | 54.66 |
| 20 | -6.7 | 46.94 |
| 25 | -3.8 | 40.40 |
| 30 | -1.1 | 34.85 |
| 35 | 1.7 | 30.18 |
| 40° | 4.4 | 26.22 |
| 45° | 7.2 | 22.85 |
| 50° | 10.0 | 19.96 |
| 55° | 12.8 | 17.47 |
| 60° | 15.6 | 15.33 |
| 65° | 18.3 | 13.4 |
| 70° | 21.1 | 11.89 |



Installation

Table 9. Temperature vs. resistance (continued)

| Temperature | | Nominal Resistance (kOhms) |
|-------------|------------|-------------------------------|
| Degrees °F | Degrees °C | |
| 75° | 23.9 | 10.50 |
| 80° | 26.7 | 9.297 |
| 85° | 29.4 | 8.247 |

Table 9. Temperature vs. resistance (continued)

| Temperature | | Nominal Resistance (kOhms) |
|-------------|------------|-------------------------------|
| Degrees °F | Degrees °C | |
| 90° | 32.2 | 7.330 |
| 95° | 35.0 | 6.528 |



Pre-Start

Use the checklist provided below in conjunction with the "General Unit Requirements" checklist to ensure that the unit is properly installed and ready for operation.

⚠ WARNING

Hazardous Voltage w/Capacitors!
 Failure to disconnect power and discharge capacitors before servicing could result in death or serious injury.
 Disconnect all electric power, including remote disconnects and discharge all motor start/run capacitors before servicing. Follow proper lockout/tagout procedures to ensure the power cannot be inadvertently energized. Verify with a CAT III or IV voltmeter rated per NFPA 70E that all capacitors have discharged.

- Check all electrical connections for tightness and point of termination accuracy.

⚠ WARNING

Rotating Components!
 Failure to disconnect power before servicing could result in rotating components cutting and slashing technician which could result in death or serious injury.
 During installation, testing, servicing and troubleshooting of this product it may be necessary to work with live and exposed rotating components. Have a qualified or licensed service individual who has been properly trained in handling exposed rotating components, perform these tasks.

- Verify that the indoor blower turn freely without rubbing and are properly tightened on the shafts.
- Verify that a condensate trap is installed and the piping is properly sized and pitched.
- Verify that the correct size and number of filters are in place.
- Inspect the interior of the unit for tools and debris and install all panels in preparation for starting the unit.

Voltage Imbalance

Three phase electrical power to the unit must meet stringent requirements for the unit to operate properly.

Measure each leg (phase-to-phase) of the power supply. Each reading must fall within the utilization range stamped on the unit nameplate. If any of the readings do not fall within the proper tolerances, notify the power company to correct this situation before operating the unit.

Excessive three phase voltage imbalance between phases will cause motors to overheat and eventually fail. The maximum allowable voltage imbalance is 2 percent.

Measure and record the voltage between phases 1, 2, and 3 and calculate the amount of imbalance as follows:

$$\% \text{ Voltage Imbalance} = \frac{100 \times AV - VD}{AV} \text{ where;}$$

$$AV \text{ (Average Voltage)} = \frac{\text{Volt1} + \text{Volt2} + \text{Volt3}}{3}$$

- V1, V2, V3 = Line Voltage Readings
- VD = Line Voltage reading that deviates the farthest from the average voltage.

Example: If the voltage readings of the supply power measured 221, 230, and 227, the average volts would be:

$$\frac{221 + 230 + 221}{3} = 226 \text{ Avg.}$$

VD (reading farthest from average) = 221

The percentage of Imbalance equals:

$$\frac{100 + 226 + 221}{226} = 2.2\%$$

The 2.2 percent imbalance in this example exceeds the maximum allowable imbalance of 2.0 percent. This much imbalance between phases can equal as much as a 20 percent current imbalance with a resulting increase in motor winding temperatures that will decrease motor life. If the voltage imbalance is over 2 percent, notify the proper agencies to correct the voltage problem before operating this equipment.

Electrical Phasing (Three Phase Motors)

The compressor motor(s) and the supply fan motor are internally connected for the proper rotation when the incoming power supply is phased as A, B, C.

Proper electrical supply phasing can be quickly determined and corrected before starting the unit by using an instrument such as an Associated Research Model 45 Phase Sequence Indicator and following the steps below:

⚠ WARNING**Hazardous Voltage w/Capacitors!**

Failure to disconnect power and discharge capacitors before servicing could result in death or serious injury.

Disconnect all electric power, including remote disconnects and discharge all motor start/run capacitors before servicing. Follow proper lockout/tagout procedures to ensure the power cannot be inadvertently energized. Verify with a CAT III or IV voltmeter rated per NFPA 70E that all capacitors have discharged.

1. Turn the field supplied disconnect switch that provides power to the main power terminal block or to the Line side of the optional factory mounted disconnect switch to the Off position.
2. Connect the phase sequence indicator leads to the terminal block or to the Line side of the optional factory mounted disconnect switch as follows;
 - Brown (phase A) to L1
 - Orange (phase B) to L2
 - Yellow (phase C) to L3
3. Close the field supplied main power disconnect switch or circuit protector switch that provides the supply power to the unit.

Note: Upon closing main power disconnect and the unit mounted disconnect switch or circuit breaker, the phase monitor will verify proper phasing. If LED on face of the monitor is red, correct supply power fault.

⚠ WARNING**Live Electrical Components!**

Failure to follow all electrical safety precautions when exposed to live electrical components could result in death or serious injury.

When it is necessary to work with live electrical components, have a qualified licensed electrician or other individual who has been properly trained in handling live electrical components perform these tasks.

To prevent injury or death from electrocution, it is the responsibility of the technician to recognize this hazard and use extreme care when performing service procedures with the electrical power energized.

4. Observe the ABC and CBA phase indicator lights on the face of the sequencer. The ABC indicator light will glow if the phase is ABC. If the CBA indicator light glows, open the disconnect switch or circuit protection switch and reverse any two power wires.
5. Restore the main electrical power and recheck the phasing. If the phasing is correct, open the disconnect switch or circuit protection switch and remove the phase sequence indicator.

Compressor Crankcase Heaters

Each compressor can be equipped with a crankcase heater (On some units the crankcase heater comes standard). The proper operation of the crankcase heater is important to maintain an elevated compressor oil temperature during the Off cycle to reduce oil foaming during compressor starts.

Oil foaming occurs when refrigerant condenses in the compressor and mixes with the oil. In lower ambient conditions, refrigerant migration to the compressor could increase.

When the compressor starts, the sudden reduction in crankcase pressure causes the liquid refrigerant to boil rapidly causing the oil to foam. This condition could damage compressor bearings due to reduced lubrication and could cause compressor mechanical failures.

Before starting the unit in the Cooling mode, set the system switch to the Off position and turn the main power disconnect to the On position and allow the crankcase heater to operate a minimum of 8 hours.

Before closing the main power disconnect switch, insure that the System selection switch is in the Off position and the Fan selection switch is in the Auto position.

Close the main power disconnect switch and the unit mounted disconnect switch, if applicable.

Note: Upon closing main power disconnect and the unit mounted disconnect switch or circuit breaker, the phase monitor will verify proper phasing. If LED on face of the monitor is red, correct supply power fault.

⚠ WARNING**Live Electrical Components!**

Failure to follow all electrical safety precautions when exposed to live electrical components could result in death or serious injury.

When it is necessary to work with live electrical components, have a qualified licensed electrician or other individual who has been properly trained in handling live electrical components perform these tasks.

To prevent injury or death from electrocution, it is the responsibility of the technician to recognize this hazard and use extreme care when performing service procedures with the electrical power energized.

Symbio Controls

The Symbio™ 700 supports a Service Test Mode that can be used to energize the various components of the system, either to support general system startup tasks or to support troubleshooting. The user can initiate Service Test Mode through the controller user interfaces, including the Symbio Service and Installation mobile application.

The modes shown below can be initiated. Depending on the equipment configuration, the controller will energize the

appropriate outputs. A user-selected timeout value will determine how long the controller will remain in any given state once initiated. For detailed information on how each Service Test State is interpreted based on the equipment's

configuration, refer to the *Symbio™ 700 Controller with Water Source Heat Pump Axiom™ Rooftop Application Guide (ACC-APG003*-EN)*.

Figure 53. Symbio 700 service test mode

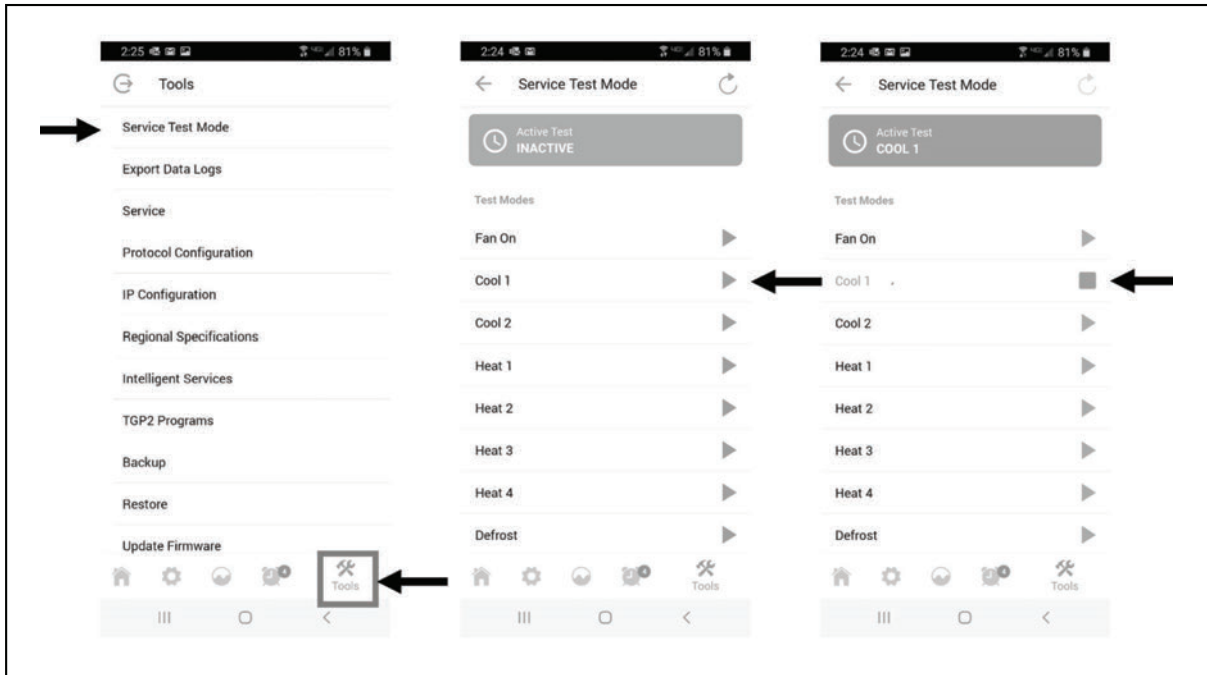



Unit Start-Up

Sequence of Operation

Refer to the *Symbio™ 700 Controller with Water Source Heat Pump Axiom™ Rooftop Application Guide* (ACC-APG003*-EN).

Return Air Smoke Detector

The return air smoke detector is designed to shut off the unit if smoke is sensed in the return air stream. Sampling the airflow entering the unit at the return air opening performs this function.

In order for the smoke detector to properly sense smoke in the return air stream, the air velocity entering the unit must be between 500 and 4000 feet per minute. Equipment covered in this manual will develop an airflow velocity that falls within these limits over the entire airflow range specified in the evaporator fan performance tables.

Compressor Start-Up

⚠ WARNING

Live Electrical Components!

Failure to follow all electrical safety precautions when exposed to live electrical components could result in death or serious injury.

When it is necessary to work with live electrical components, have a qualified licensed electrician or other individual who has been properly trained in handling live electrical components perform these tasks.

1. Attach a set of service gauges onto the suction and discharge gauge ports for each circuit.
Proceed to the next Service Test step if continuing from previous component start-up or until the desired start-up component test is started.
2. After the compressor has started and operated for approximately 30 minutes, observe the operating pressures. Compare the operating pressures to the label on the access panel.
3. Check system superheat. Follow the instruction listed on the superheat charging curve in the Service Facts. Superheat should be within $\pm 5^{\circ}\text{F}$ of the superheat chart value.
4. Repeat [Step 1](#) through [Step 4](#) for each refrigerant circuit.
5. To stop the Service Test, turn the main power disconnect switch to the Off position or proceed to the next component start-up procedure. Remove electromechanical test mode connections (if applicable).

Hot Gas Reheat

⚠ WARNING

Live Electrical Components!

Failure to follow all electrical safety precautions when exposed to live electrical components could result in death or serious injury.

When it is necessary to work with live electrical components, have a qualified licensed electrician or other individual who has been properly trained in handling live electrical components perform these tasks.

Set the unit to Service Test step Reheat. Once the unit is in the reheat test mode, verify that the 3 way valve has shifted to the reheat position and that the supply temperature rises 10°F more than when in cooling mode stage 2 (12.5-15 Tons) or stage 3 (20-25 Tons).

Monitor the suction pressure for 15 minutes. The suction pressure should remain within 5 psi of normal cooling operation.

1. Clamp an amp meter around one of 1st stage heater power wires at the heater contactor.
2. Using the Service Test Guide in [Figure 53, p. 55](#), continue the Service Test start-up procedure for each compressor circuit.
Select the next desired Service Test Mode if continuing from previous component start up or exit Service Test if complete.

Final System Setup

After completing all of the pre-start and startup procedures outlined in the previous sections (i.e., operating the unit in each of its modes through all available stages of cooling and heating), perform these final checks before leaving the unit:

- Program the Night Setback (NSB) panel (if applicable) for proper unoccupied operation. Refer to the programming instructions for the specific panel.
- Verify that the Remote Panel System Selection switch, Fan Selection switch, and Zone Temperature settings for automatic operation are correct.
- Inspect the unit for misplaced tools, hardware, and debris.
- Verify that all exterior panels including the control panel doors are secured in place.
- Close the main disconnect switch or circuit protector switch that provides the supply power to the units terminal block or the unit mounted disconnect switch.

⚠ WARNING

Safety Alert!

Failure to follow instructions below could result in death or serious injury.

In addition to the following tasks, you **MUST**:

- Follow all instructions in the unit's *Installation, Operation, and Maintenance* manual, including warnings, cautions, and notices.
- Perform all required tasks in any applicable Service Alerts and Service Bulletins.
- Review and understand all information provided in Submittals and Design Specifications.

Table 10. Water volume for GSK* units

| Unit Size | Water Side Volume(in. ³) | Water Side Volume(ft. ³) | Water Side Volume(gallons) |
|---------------|--------------------------------------|--------------------------------------|----------------------------|
| GSK036 | 123.1 | 0.071 | 0.533 |
| GSK048 | 209.0 | 0.121 | 0.905 |
| GSK060 | 250.5 | 0.145 | 1.084 |
| *GSK072 - 092 | 332.6 | 0.192 | 1.439 |
| *GSK102 - 120 | 468.0 | 0.271 | 2.026 |
| *GSK150 - 210 | 809.7 | 0.469 | 3.505 |
| *GSK240 - 300 | 1072.2 | 0.620 | 4.642 |

Note: Volume includes headers.



Maintenance

⚠ WARNING

Hazardous Service Procedures!

Failure to follow all precautions in this manual and on the tags, stickers, and labels could result in death or serious injury.

Technicians, in order to protect themselves from potential electrical, mechanical, and chemical hazards, **MUST** follow precautions in this manual and on the tags, stickers, and labels, as well as the following instructions: Unless specified otherwise, disconnect all electrical power including remote disconnect and discharge all energy storing devices such as capacitors before servicing. Follow proper lockout/tagout procedures to ensure the power can not be inadvertently energized. When necessary to work with live electrical components, have a qualified licensed electrician or other individual who has been trained in handling live electrical components perform these tasks.

Monthly Maintenance

Before completing the following checks, turn the unit **OFF** and lock the main power disconnect switch open.

⚠ WARNING

Hazardous Voltage!

Failure to disconnect power before servicing could result in death or serious injury.

Disconnect all electric power, including remote disconnects before servicing. Follow proper lockout/tagout procedures to ensure the power can not be inadvertently energized. Verify that no power is present with a voltmeter.

Filters

Inspect the return air filters. Clean or replace them if necessary.

Return Air Smoke Detector Maintenance

Airflow through the unit is affected by the amount of dirt and debris accumulated on the indoor coil and filters. To insure that airflow through the unit is adequate for proper sampling by the return air smoke detector, complete adherence to the maintenance procedures, including recommended intervals between filter changes, and coil cleaning is required.

Periodic checks and maintenance procedures must be performed on the smoke detector to insure that it will function properly. For detailed instructions concerning these checks and procedures, refer to the appropriate section(s) of the smoke detector Installation and Maintenance Instructions provided with the literature package for this unit.

Condensate Overflow Switch

During maintenance, the switch float (black ring) must be checked to ensure free movement up and down.

Cooling Season

- Check the units drain pans and condensate piping to ensure that there are no blockages.
- Inspect the evaporator and coils for dirt, bent fins, etc. If the coils appear dirty, clean them according to the instructions described in “Coil Cleaning,” p. 59.
- Inspect the F/A-R/A damper hinges and pins to ensure that all moving parts are securely mounted. Keep the blades clean as necessary.
- Verify that all damper linkages move freely; lubricate with white grease, if necessary.
- Check supply fan motor bearings; repair or replace the motor as necessary.
- Verify that all wire terminal connections are tight.
- Remove any corrosion present on the exterior surfaces of the unit and repaint these areas.
- Generally inspect the unit for unusual conditions (e.g., loose access panels, leaking piping connections, etc.).
- Make sure that all retaining screws are reinstalled in the unit access panels once these checks are complete.
- With the unit running, check and record the following:
 - ambient temperature
 - compressor suction and discharge pressures (each circuit)
 - superheat (each circuit)

Record this data on an operators maintenance log like the one shown in [Table 13, p. 60](#). If the operating pressures indicate a refrigerant shortage, measure the system superheat. For guidelines, see “[Compressor Start-Up](#),” p. 56.

Important: *Do not release refrigerant to the atmosphere! If adding or removing refrigerant is required, the service technician must comply with all federal, state and local laws.*

Heating Season

- Inspect the units air filters. If necessary, clean or replace them.
- Check supply fan motor bearings; repair or replace the motor as necessary.
- Inspect both the main unit control panel and heat section control box for loose electrical components and terminal connections, as well as damaged wire insulation. Make any necessary repairs.
- Verify that the electric heat system operates properly.

Coil Cleaning

Regular coil maintenance, including annual cleaning, enhances the units operating efficiency by minimizing the following:

- Compressor head pressure and amperage draw
- Evaporator water carryover
- Fan brake horsepower
- Due to increase static pressure losses
- Airflow reduction

⚠ WARNING

Hazardous Chemicals!

Failure to follow this safety precaution could result in death or serious injury. Coil cleaning agents can be either acidic or highly alkaline and can burn severely if contact with skin or eyes occurs.

Handle chemical carefully and avoid contact with skin. ALWAYS wear Personal Protective Equipment (PPE) including goggles or face shield, chemical resistant gloves, boots, apron or suit as required. For personal safety refer to the cleaning agent manufacturer's Materials Safety Data Sheet and follow all recommended safe handling practices.

Coil Cleaning Procedure

1. Remove enough panels from the unit to gain access to the coil.
2. Protect all electrical devices such as motors and controllers from any over spray.
3. Straighten any bent coil fins with a fin comb.
4. Mix the detergent with water according to the manufacturers instructions. If desired, heat the solution to 150° F maximum to improve its cleansing capability.

⚠ WARNING

Hazardous Pressures!

Failure to follow instructions below could result in a violent explosion, which could result in death or serious injury.

If a heat source is required to raise the tank pressure during removal of refrigerant from cylinders, use only warm water or heat blankets to raise the tank temperature. Do not exceed a temperature of 150°F. Do not under any circumstances apply direct flame to any portion of the cylinder.

Do not heat the detergent-and-water solution above 150°F. Hot liquids sprayed on the exterior of the coil will raise the coils internal pressure and may cause it to burst. Failure to follow proper procedures can result in personal illness or injury or severe equipment damage.

5. Pour the cleaning solution into the sprayer. If a high pressure sprayer is used:

- a. Do not allow sprayer pressure to exceed 600 psi.
 - b. The minimum nozzle spray angle is 15 degrees.
 - c. Maintain a minimum clearance of 6–inch between the sprayer nozzle and the coil.
 - d. Spray the solution perpendicular (at 90 degrees) to the coil face.
6. Spray the leaving-airflow side of the coil first; then spray the opposite side of the coil. Allow the cleaning solution to stand on the coil for five minutes.
 7. Rinse both sides of the coil with cool, clean water.
 8. Inspect both sides of the coil; if it still appears to be dirty, repeat step 6 and step 7.
 9. Reinstall all of the components and panels removed in [Step 1](#) and any protective covers installed in [Step 2](#).
 10. Restore the unit to its operational status and check system operation.

Hot Gas Reheat Additional Oil

NOTICE

Compressor Damage!

Use of incorrect refrigerant and oil could result in compressor damage and improper unit operation. Use only refrigerant and oil specified on the unit nameplate.

Additional refrigerant oil has been added in the factory for all Hot Gas Reheat units. If major components (coil, valve assembly, etc.) are replaced or serviced, the following steps must be taken:

1. Measure the amount of oil removed during servicing.
2. When recharging the unit after servicing, replace the amount of oil removed, as measured in. Verify oil added is the correct type.
3. For compressor replacements and/or additional questions, contact Technical Support.

Water Quality

It should be noted that the water quality should be checked periodically (See below).

Table 11. Water quality

| Scaling | Amount |
|--|-------------------|
| Calcium and magnesium (total hardness) | Less than 350 ppm |
| Corrosion | – |
| pH | 7-9.5 |
| Hydrogen Sulfide | Less than 1 ppm |
| Sulfates | Less than 25 ppm |
| Chlorides | Less than 125 ppm |
| Carbon Dioxide | Less than 75 ppm |



Maintenance

Table 11. Water quality (continued)

| Scaling | Amount |
|------------------------------|--------------------|
| Total dissolved solids (TDS) | Less than 1000 ppm |
| Biological Growth | – |
| Iron Bacteria | Low |
| Erosion | – |
| Suspended Solids | Low |

Annual Maintenance

Clean and repaint any corroded surface.

Final Process

For future reference, record the unit data below in the blanks provided.

Table 12. Unit data log

| | |
|--|--|
| Complete Unit Model Number | |
| Unit Serial Number | |
| Wiring Diagram Numbers (from unit control panel) | |
| Connections | |
| Schematics | |

Table 13. Sample maintenance log

| Date | Current Ambient Temp F/C | Refrigerant Circuit #1 | | | | | | Refrigerant Circuit #2 | | | | | |
|------|--------------------------|------------------------|------------------------|------------------------|------------------------|-----------------|--------------|------------------------|------------------------|------------------------|------------------------|-----------------|--------------|
| | | Compr. Oil Level | Suct. Press. Psig/ kPa | Disch. Press Psig/ kPa | Liquid Press Psig/ kPa | Super-heat F/ C | Sub-cool F/C | Compr. Oil Level | Suct. Press. Psig/ kPa | Disch. Press Psig/ kPa | Liquid Press Psig/ kPa | Super-heat F/ C | Sub-cool F/C |
| | | - ok - low | | | | | | - ok - low | | | | | |
| | | - ok - low | | | | | | - ok - low | | | | | |
| | | - ok - low | | | | | | - ok - low | | | | | |
| | | - ok - low | | | | | | - ok - low | | | | | |
| | | - ok - low | | | | | | - ok - low | | | | | |
| | | - ok - low | | | | | | - ok - low | | | | | |

Note: Check and record the data requested above each month during the cooling season with the unit running.



Troubleshooting

Refer to the *Symbio™ 700 Controller with Water Source Heat Pump Axiom™ Rooftop Application Guide* (ACC-APG003*-EN).



Wiring Diagrams

Note: Wiring diagrams can be accessed using e-Library by entering the diagram number in the literature order number search field or by contacting technical support.

Table 14. Wiring diagrams

| Schematic Type | Controls | Voltage | Drawing Number | Description |
|----------------|------------|---------|----------------|---|
| Main Unit | Symbio 700 | All | 12134795 | SCHEMATIC; SHEET 1, POWER, SINGLE COMPRESSOR, WSHP, STD SCCR |
| Main Unit | Symbio 700 | All | 12134798 | SCHEMATIC; SHEET 1, POWER, SINGLE COMPRESSOR, WSHP, HIGH SCCR |
| Main Unit | Symbio 700 | All | 12135025 | SCHEMATIC; SHEET 1, POWER, DUAL COMPRESSOR, WSHP, STD SCCR |
| Main Unit | Symbio 700 | All | 12135026 | SCHEMATIC; SHEET 1, POWER, DUAL COMPRESSOR, WSHP, HIGH SCCR |
| Main Unit | Symbio 700 | All | 12134548 | SCHEMATIC; SHEET 1, POWER, DUAL COMPRESSOR, WSHP, STD SCCR |
| Main Unit | Symbio 700 | All | 12134549 | SCHEMATIC; SHEET 1, POWER, DUAL COMPRESSOR, WSHP, HIGH SCCR |
| Main Unit | Symbio 700 | All | 12134799 | SCHEMATIC; SHEET 2, POWER, SINGLE INDOOR FAN, COOLING ONLY/ ELECTRIC HEAT, STD SCCR, MULTI-TAP MOTOR |
| Main Unit | Symbio 700 | All | 12134802 | SCHEMATIC; SHEET 2, POWER, SINGLE INDOOR FAN, COOLING ONLY/ ELECTRIC HEAT, HIGH SCCR, MULTI-TAP MOTOR |
| Main Unit | Symbio 700 | All | 12134921 | SCHEMATIC; SHEET 2, POWER, SINGLE INDOOR FAN, COOLING ONLY/ ELECTRIC HEAT, STD SCCR |
| Main Unit | Symbio 700 | All | 12134942 | SCHEMATIC; SHEET 2, POWER, SINGLE INDOOR FAN, COOLING ONLY/ ELECTRIC HEAT, HIGH SCCR |
| Main Unit | Symbio 700 | All | 12134827 | SCHEMATIC; SHEET 2, POWER, DUAL INDOOR FAN, COOLING ONLY/ ELECTRIC HEAT, STD SCCR |
| Main Unit | Symbio 700 | All | 12134830 | SCHEMATIC; SHEET 2, POWER, DUAL INDOOR FAN, COOLING ONLY/ ELECTRIC HEAT, HIGH SCCR |
| Main Unit | Symbio 700 | All | 12134806 | SCHEMATIC; SHEET 3, CONTROLS, SYMBIO 700 UNIT CONTROLS, HEAT PUMP |
| Main Unit | Symbio 700 | All | 12134852 | SCHEMATIC; SHEET 3, CONTROLS, SYMBIO 700 UNIT CONTROLS, HEAT PUMP |
| Main Unit | Symbio 700 | All | 12135031 | SCHEMATIC; SHEET 3, CONTROLS, SYMBIO 700 UNIT CONTROLS, HEAT PUMP |
| Main Unit | Symbio 700 | All | 12134808 | SCHEMATIC; SHEET 4, CONTROLS, ADAPTER BOARD UNIT CONTROLS, SINGLE COMPRESSOR, WSHP, A CAB |
| Main Unit | Symbio 700 | All | 12134550 | SCHEMATIC; SHEET 4, CONTROLS, ADAPTER BOARD UNIT CONTROLS, DUAL COMPRESSOR, WSHP |
| Main Unit | Symbio 700 | All | 12134445 | SCHEMATIC; SHEET 5, CONTROLS, INDOOR OPTIONS |
| Main Unit | Symbio 700 | All | 12134438 | SCHEMATIC; SHEET 6, CONTROLS, FRESH AIR OPTIONS |
| Main Unit | Symbio 700 | All | 12134446 | SCHEMATIC; SHEET 7, CONTROLS, CUSTOMER CONNECTION OPTIONS |
| Main Unit | Symbio 700 | All | 12134447 | SCHEMATIC; SHEET 8, CONTROLS, STEPPER MOTOR CONTROLLER |
| Main Unit | Symbio 700 | All | 12134448 | SCHEMATIC; SHEET 9, CONTROLS, XM30/XM32 EXPANSION MODULES |
| Electric Heat | Symbio 700 | 230V | 12134301 | SCHEMATIC/COMPONENT LOCATION – ELECTRIC HEAT – 9 and 18 kW 208/240V |
| Electric Heat | Symbio 700 | 230V | 12134302 | SCHEMATIC/COMPONENT LOCATION – ELECTRIC HEAT – 27 and 36 kW 208/240V |

Table 14. Wiring diagrams (continued)

| Schematic Type | Controls | Voltage | Drawing Number | Description |
|--------------------|------------|-----------|----------------|--|
| Electric Heat | Symbio 700 | 230V | 12134303 | SCHEMATIC/COMPONENT LOCATION – ELECTRIC HEAT – 54 kW 208/240V |
| Electric Heat | Symbio 700 | 460V/575V | 12134304 | SCHEMATIC/COMPONENT LOCATION – ELECTRICHEAT – 9 and 18kW 460/575V |
| Electric Heat | Symbio 700 | 460V/575V | 12134305 | SCHEMATIC/COMPONENT LOCATION – ELECTRIC HEAT – 27 and 36 kW 460/575V |
| Electric Heat | Symbio 700 | 460V/575V | 12134306 | SCHEMATIC/COMPONENT LOCATION – ELECTRIC HEAT – 54 kW 460/575V |
| Electric Heat | Symbio 700 | 230V | 12134307 | SCHEMATIC/COMPONENT LOCATION – ELECTRIC HEAT - 18 kW 208/240V |
| Electric Heat | Symbio 700 | 230V | 12134308 | SCHEMATIC/COMPONENT LOCATION – ELECTRIC HEAT – 36 kW 208/240V |
| Electric Heat | Symbio 700 | 230V | 12134309 | SCHEMATIC/COMPONENT LOCATION – ELECTRICHEAT – 54 and 72 kW 208/240V |
| Electric Heat | Symbio 700 | 460V/575V | 12134310 | SCHEMATIC/COMPONENT LOCATION – ELECTRIC HEAT – 18 kW 460/575V |
| Electric Heat | Symbio 700 | 460V/575V | 12134311 | SCHEMATIC/COMPONENT LOCATION – ELECTRIC HEAT – 36 kW 460/575V |
| Electric Heat | Symbio 700 | 460V/575V | 12134312 | SCHEMATIC/COMPONENT LOCATION – ELECTRIC HEAT – 54 and 72 kW 460/575V |
| Component Location | Symbio 700 | All | 12134817 | DIAGRAM; COMPONENT LOCATION, COOLING/ELECTRIC, A CABINET, HEAT PUMP |
| Component Location | Symbio 700 | All | 12134964 | DIAGRAM; COMPONENT LOCATION, COOLING/ELECTRIC, B CABINET, HEAT PUMP |
| Component Location | Symbio 700 | All | 12134968 | DIAGRAM; COMPONENT LOCATION, COOLING/ELECTRIC, C CABINET, HEAT PUMP |
| Component Location | Symbio 700 | All | 12134856 | DIAGRAM; COMPONENT LOCATION, COOLING/ELECTRIC, D CABINET, HEAT PUMP |
| Supplemental | Symbio 700 | All | 12134327 | DIAGRAM; POWER EXHAUST |
| Supplemental | Symbio 700 | All | 12134461 | DIAGRAM; SCHEMATIC – CONVENIENCE OUTLET OPTION |

Piping Diagrams

Figure 54. Piping diagram – 3 to 25 tons standard efficiency

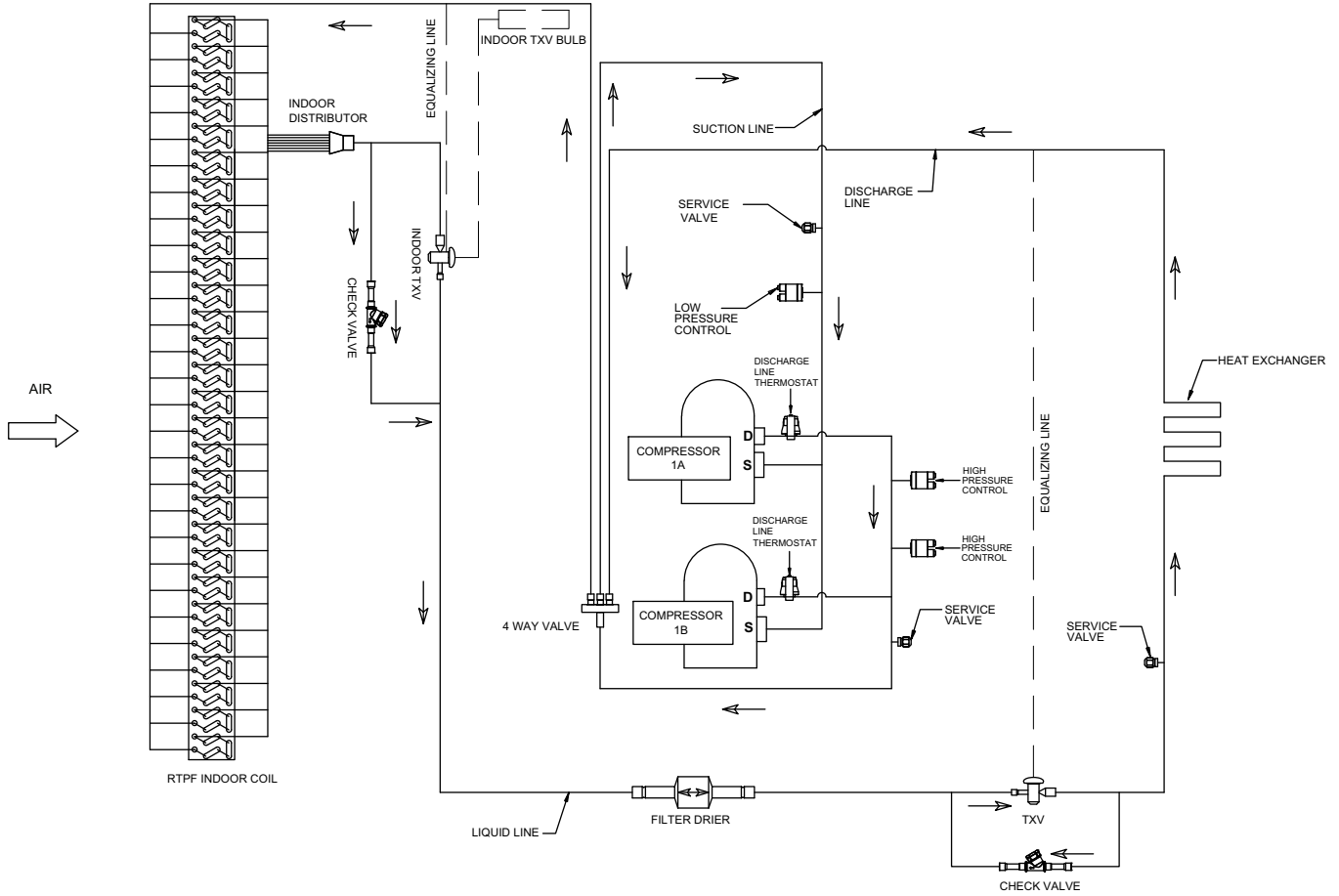

Note: 3 to 10 tons unit have only one compressor.

Figure 55. Piping diagram – 3 to 25 tons standard efficiency – hot gas reheat

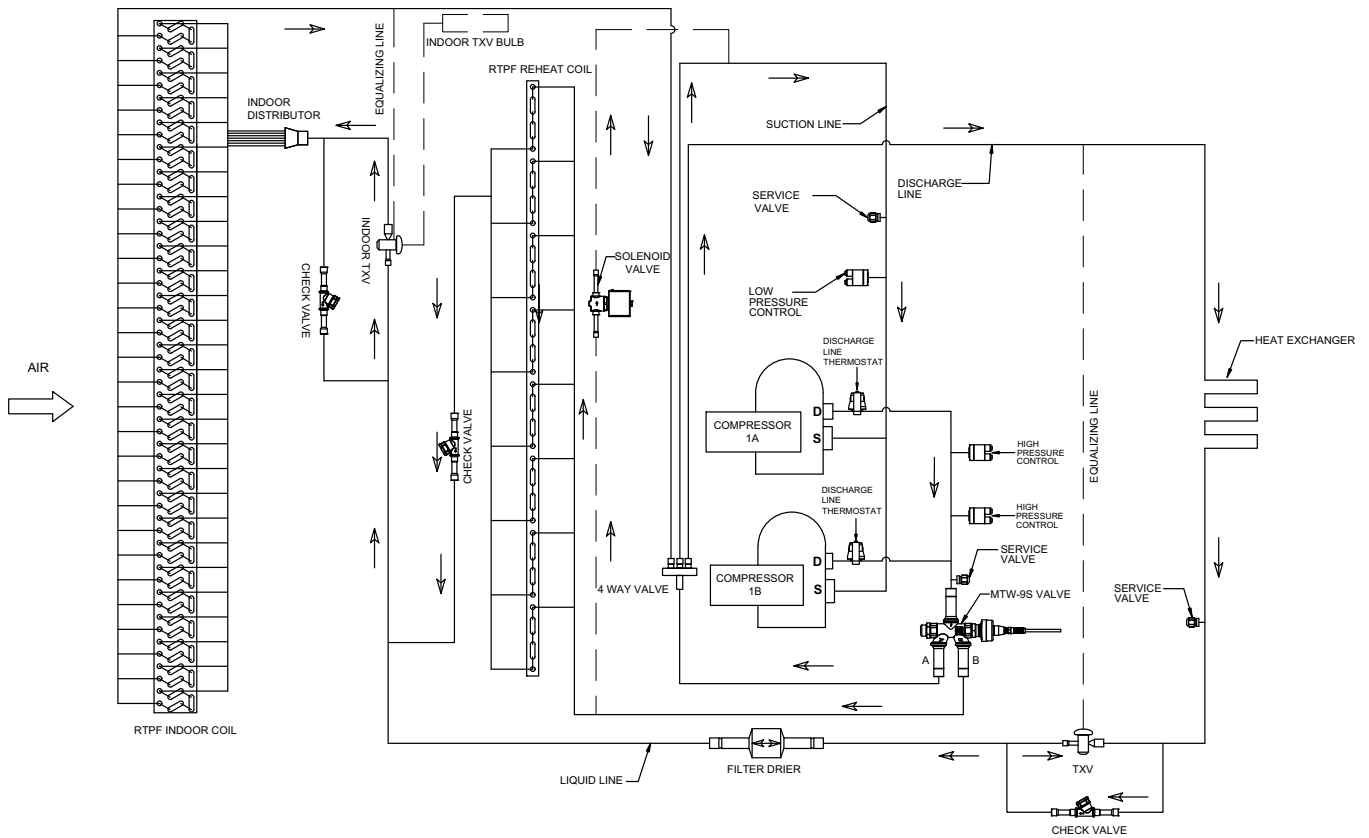

Note: 3 to 10 tons unit have only one compressor.



Limited Warranty

Electric Air Conditioner

GSK

This warranty is extended by Trane to the original purchaser and to any succeeding owner of the real property to which the Electric/ Electric Air Conditioner is originally affixed and applies to products purchased and retained for use within the U.S.A. and Canada. The company warrants for a period of 12 months from initial start-up or 18 months from date of shipment, whichever is less, that the company products covered by this order (1) are free from defects in material and workmanship and (2) have the capacities and ratings set forth in the company's catalogs and bulletins.

There is no warranty against corrosion, erosion or deterioration. If any part of your Electric/ Electric Air Conditioner fails because of a manufacturing defect within one year (12 months) from the date of the original purchase, warrantor will furnish without charge the required replacement part.

In addition, if the sealed motor-compressor fails because of a manufacturing defect within five years from the date of original purchase, warrantor will furnish without charge the required replacement compressor.

Warrantor's obligations and liabilities under this warranty are limited to furnishing F.O.B. warrantor factory or warehouse at warrantor designated shipping point, freight allowed to buyer's city, replacement parts for warrantor's products covered under this warranty. Warrantor shall not be obligated to pay for the cost of lost refrigerant. No liability shall attach to warrantor until products have been paid for and then liability shall be limited solely to the purchase price of the equipment under warranty shown to be defective.

THE WARRANTY AND LIABILITY SET FORTH HEREIN ARE IN LIEU OF ALL OTHER WARRANTIES AND

LIABILITIES, WHETHER IN CONTRACT OR IN NEGLIGENCE, EXPRESS OR IMPLIED, IN LAW OR IN FACT, INCLUDING IMPLIED WARRANTIES OF MERCHANTABILITY AND FITNESS FOR PARTICULAR USE, AND IN NO EVENT SHALL WARRANTOR BE LIABLE FOR ANY INCIDENTAL OR CONSEQUENTIAL DAMAGES.

Some states do not allow limitations on how long an implied warranty lasts or do not allow the exclusion or limitation of incidental or consequential damages, so the above limitation or exclusion may not apply to you. This warranty gives you specific legal rights, and you may also have other rights which vary from state to state.

Trane Technologies

182 Cotton Belt Parkway

McGregor, TX 76657

Attention: Manager, Product Service

GW-606-4800

The Company makes certain further warranty protection available on an optional extra-cost basis. Any further warranty must be in writing, signed by an officer of the company.

The warranty and liability set forth herein are in lieu of all other warranties and liabilities, whether in contract or in negligence, express or implied, in law or in fact, including implied warranties of merchantability and fitness for particular use. In no event shall the company be liable for any incidental or consequential damages.

* This warranty is for commercial usage of said equipment and not applicable when the equipment is used for a residential application. Commercial use is any application where the end purchaser uses the product for other than personal, family or household purposes.

Trane - by Trane Technologies (NYSE: TT), a global innovator - creates comfortable, energy efficient indoor environments for commercial and residential applications. For more information, please visit trane.com or tranetechnologies.com.

Trane has a policy of continuous product and product data improvements and reserves the right to change design and specifications without notice. We are committed to using environmentally conscious print practices.