



Installation, Operation, and Maintenance
Water Source Heat Pump
Axiom™ High Efficiency Vertical
Stack – GET
0.75 to 3 Tons – 60 Hz



⚠ SAFETY WARNING

Only qualified personnel should install and service the equipment. The installation, starting up, and servicing of heating, ventilating, and air-conditioning equipment can be hazardous and requires specific knowledge and training. Improperly installed, adjusted or altered equipment by an unqualified person could result in death or serious injury. When working on the equipment, observe all precautions in the literature and on the tags, stickers, and labels that are attached to the equipment.



Introduction

Read this manual thoroughly before operating or servicing this unit.

Warnings, Cautions, and Notices

Safety advisories appear throughout this manual as required. Your personal safety and the proper operation of this machine depend upon the strict observance of these precautions.

The three types of advisories are defined as follows:



Indicates a potentially hazardous situation which, if not avoided, could result in death or serious injury.



Indicates a potentially hazardous situation which, if not avoided, could result in minor or moderate injury. It could also be used to alert against unsafe practices.



Indicates a situation that could result in equipment or property-damage only accidents.

Important Environmental Concerns

Scientific research has shown that certain man-made chemicals can affect the earth's naturally occurring stratospheric ozone layer when released to the atmosphere. In particular, several of the identified chemicals that may affect the ozone layer are refrigerants that contain Chlorine, Fluorine and Carbon (CFCs) and those containing Hydrogen, Chlorine, Fluorine and Carbon (HCFCs). Not all refrigerants containing these compounds have the same potential impact to the environment. Trane advocates the responsible handling of all refrigerants.

Important Responsible Refrigerant Practices

Trane believes that responsible refrigerant practices are important to the environment, our customers, and the air conditioning industry. All technicians who handle refrigerants must be certified according to local rules. For the USA, the Federal Clean Air Act (Section 608) sets forth the requirements for handling, reclaiming, recovering and recycling of certain refrigerants and the equipment that is used in these service procedures. In addition, some states or municipalities may have additional requirements that must also be adhered to for responsible management of refrigerants. Know the applicable laws and follow them.

⚠ WARNING

Proper Field Wiring and Grounding Required!

Failure to follow code could result in death or serious injury.

All field wiring **MUST** be performed by qualified personnel. Improperly installed and grounded field wiring poses **FIRE** and **ELECTROCUTION** hazards. To avoid these hazards, you **MUST** follow requirements for field wiring installation and grounding as described in **NEC** and your local/state/national electrical codes.

⚠ WARNING

Personal Protective Equipment (PPE) Required!

Failure to wear proper PPE for the job being undertaken could result in death or serious injury.

Technicians, in order to protect themselves from potential electrical, mechanical, and chemical hazards, **MUST** follow precautions in this manual and on the tags, stickers, and labels, as well as the instructions below:

- **Before installing/servicing this unit, technicians MUST put on all PPE required for the work being undertaken (Examples; cut resistant gloves/sleeves, butyl gloves, safety glasses, hard hat/bump cap, fall protection, electrical PPE and arc flash clothing). ALWAYS refer to appropriate Safety Data Sheets (SDS) and OSHA guidelines for proper PPE.**
- **When working with or around hazardous chemicals, ALWAYS refer to the appropriate SDS and OSHA/GHS (Global Harmonized System of Classification and Labelling of Chemicals) guidelines for information on allowable personal exposure levels, proper respiratory protection and handling instructions.**
- **If there is a risk of energized electrical contact, arc, or flash, technicians MUST put on all PPE in accordance with OSHA, NFPA 70E, or other country-specific requirements for arc flash protection, PRIOR to servicing the unit. NEVER PERFORM ANY SWITCHING, DISCONNECTING, OR VOLTAGE TESTING WITHOUT PROPER ELECTRICAL PPE AND ARC FLASH CLOTHING. ENSURE ELECTRICAL METERS AND EQUIPMENT ARE PROPERLY RATED FOR INTENDED VOLTAGE.**

⚠ WARNING**Follow EHS Policies!**

Failure to follow instructions below could result in death or serious injury.

- All Trane personnel must follow the company's Environmental, Health and Safety (EHS) policies when performing work such as hot work, electrical, fall protection, lockout/tagout, refrigerant handling, etc. Where local regulations are more stringent than these policies, those regulations supersede these policies.
- Non-Trane personnel should always follow local regulations.

⚠ WARNING**R-454B Flammable A2L Refrigerant!**

Failure to use proper equipment or components as described below could result in equipment failure, and possibly fire, which could result in death, serious injury, or equipment damage.

The equipment described in this manual uses R-454B refrigerant which is flammable (A2L). Use ONLY R-454B rated service equipment and components. For specific handling concerns with R-454B, contact your local representative.

⚠ WARNING**Electrical Shock Hazard!**

Failure to follow instructions below could result in death or serious injury.

Properly connect the system's oversized protective earthing (grounding) terminal(s).

Copyright

This document and the information in it are the property of Trane, and may not be used or reproduced in whole or in part without written permission. Trane reserves the right to revise this publication at any time, and to make changes to its content without obligation to notify any person of such revision or change.

Trademarks

All trademarks referenced in this document are the trademarks of their respective owners.

Product Safety Information

This appliance is not intended for use by persons (including children) with reduced physical, sensory or mental capabilities, or lack of experience and knowledge, unless they have been given supervision or instruction concerning use of the appliance by a person responsible for their safety. Children should be supervised to ensure that they do not play with the appliance.

Maximum altitude of use 3000 meters.

This appliance incorporates an earth connection for functional purposes only.

Factory Training

Factory training is available through Trane University™ to help you learn more about the operation and maintenance of your equipment. To learn about available training opportunities, contact Trane University™.

Online: www.trane.com/traneuniversity

Email: traneuniversity@trane.com

Revision History

- Updated A2L chapter.
- Removed duplicate data.



Table of Contents

Model Number Description	6	Refrigerant Removal and Evacuation	19
Vertical High-Rise Cabinet WSHP	6	Refrigerant Charging	20
Vertical High-Rise Chassis WSHP	8	Decommissioning	20
General Information	9	A2L Application Considerations	20
Blower/Motor	9	Ignition Sources in Ductwork	21
Compressor Nameplate	9	Ignition Sources in Unit	21
Controls	9	Minimum Room Area Limits (Refrigerant charge greater than 3.91 lb per circuit)	21
Deluxe 24V Controls	9	Leak Detection System (Refrigerant charge greater than 3.91 lb per circuit)	22
Schrader Connections	9	Installation	23
Sound Attenuation	9	General Installation Checks	23
Unit Description	9	Main Electrical	23
Unit Nameplate	9	Low Voltage Wiring (AC and DC) Requirements	23
Water Connections	9	Unit Placement	23
Water-to-Refrigerant Coils	9	Water Connection	24
Symbio™ 400-B	9	Field Installed Power Wiring	25
Operating Limits	10	Main Unit Power Wiring	25
Pre-Installation	11	Control Power Transformer	25
Jobsite Inspection	11	Drywall Installation	26
Jobsite Storage	11	Units Utilizing Hinged Acoustic Door Assembly	26
Dimensions and Weights	13	Supply Air Ductwork	27
Unit Location and Clearances	13	Chassis Installation	27
Dimensions and Weights with Standard Base	14	Supply Grille Installation	28
Dimensions and Weights with 6-inch Extended Base	15	Cleaning and Flushing the Water Loop	28
Return Air (Hinged) Acoustical Door with Standard Base	16	Using Antifreeze	29
Return Air (Hinged) Acoustical Door with 6-inch Extended Base	17	Low Voltage Wiring	29
A2L Information and Installation Requirements	18	Low Voltage Wiring for Field Provided Thermostats/Zone Sensors	29
Installation/Code Compliance Requirements	18	PSC Blower Motor Speed Retrofit	30
A2L Work Procedures	18	ECM CFM Settings	31
Servicing	18	Pre-Start-Up	35
Leak Detection	19	Checklist	35
		Initial Unit Start-Up	35

Operating Pressures	36	Troubleshooting	42
Water Pressure Drop	38	Preliminary Trouble Inspection	42
Water Volume	39	General Operation	42
Flow Checks	39	Operation with a Conventional	
Pressure	39	Thermostat	42
Start-Up	40	Unit Wiring	44
Start-Up Checklist and Log	40	Warranty	48
Maintenance	41	Standard Warranty	48
Preventive Maintenance	41	Extended Warranty	48



Model Number Description

Vertical High-Rise Cabinet WSHP

Digits 1, 2, 3 — Unit Configuration

GET = High Efficiency Vertical High Rise Heat Pump

Digit 4 — Development Sequence

K = R-454B

Digits 5, 6, 7 — Nominal Size (Tons)

009 = 0.75 Tons
012 = 1 Tons
015 = 1.25 Tons
018 = 1.5 Tons
024 = 2 Tons
036 = 3 Tons

Digit 8 — Voltage (Volts/Hz/Phase)

1 = 208/60/1
2 = 230/60/1
7 = 265/60/1

Digit 9 — Heat Exchanger

1 = Copper-Water Coil
2 = Cupro-Nickel Water Coil
3 = Copper Water Coil with Isolation Valve and Low Flow Control
4 = Cupro- Nickel Water Coil with Isolation Valve and Low Flow Control
5 = Copper Water Coil with Isolation Valve and High Flow Control
6 = Cupro-Nickel Water Coil with Isolation Valve and High Flow Control

Digit 10 — Current Design Sequence

Digit 11 — Refrigeration Circuit

0 = Heating and Cooling Circuit

Digit 12 — Blower Configuration

1 = Free Discharge (Factory Wire Low Speed) - PSC motor
2 = Ducted (Factory Wire Hi Speed) - PSC motor
3 = Free Discharge with 1-inch Flange - PSC motor
4 = Free Discharge with 3-inch Flange - PSC motor
5 = ECM without Flange
6 = ECM with 1-inch Flange
7 = ECM with 3-inch Flange
8 = Chassis only/No Motor (ECM Control)
9 = Chassis only/No Motor (PSC Control)

Digit 13 — Freeze Protection

A = 20°F Freezestat (For Glycol loop)
B = 35°F Freezestat (For Water loop)

Digit 14 — Open Digit

0 = Open
S = Special

Digit 15 — Supply-Air Arrangement

0 = Field Cut Supply Air Arrangement
1 = Back and Front Supply Air Arrangement
2 = Back and Left Supply Air Arrangement
3 = Back and Right Supply Air Arrangement
4 = Front and Left Supply Air Arrangement
5 = Front and Right Supply Air Arrangement
6 = Left and Right Supply Air Arrangement
7 = Back, Front and Right Supply Air Arrangement
8 = Back, Front and Left Supply Air Arrangement
9 = Front, Right and Left Supply Air Arrangement
B = Back Supply Air Arrangement
L = Left Supply Air Arrangement
R = Right Supply Air Arrangement
T = Top Supply Air Arrangement
F = Front Supply Air Arrangement

Digit 16 — Return-Air Arrangement

0 = No Door
1 = Hinged Return Air Door
3 = Hinged Return Air Door, Tamper Resistant (HEX)
4 = Hinged Return Air Door, with Key Lock

Digit 17 — Control Types

D = Deluxe 24 V Controls
H = Symbio™ 400-B
J = Symbio 400-B with Air-Fi® Wireless Communications

Digit 18 — Thermostat Sensor Location

0 = Wall Mounted Location

Digit 19 — Fault Sensors

0 = No Fault Sensors
1 = Condensate Overflow Sensor
2 = Filter Maintenance Timer
3 = Condensate Overflow and Filter Maintenance Timer

Digit 20 — Temperature Sensor

0 = No Additional Temperature Sensors
1 = Entering Water Sensor

Digit 21, 22 — Open Digits

Digit 23 — Unit Mounted Disconnect

0 = No Unit Mounted Switch
C = ON/OFF Switch
D = ON/OFF Switch with Fuses

Digit 24 — Filter Type

1 = 1-inch Throwaway Filter

Digit 25 — Acoustic Arrangement

0 = Enhanced Sound Attenuation
1 = Deluxe Sound Attenuation

Digit 26 — Factory Configuration

3 = Cabinet Only with Standard Base
4 = Cabinet Only with 6-inch Extended Base

Digits 27 — Paint Color

9 = Light White Finish

Digits 28 — Outside Air Option

0 = No Outside Air

Digits 29 — Piping Arrangement

B = Back Riser Location
L = Left Hand Riser Location
R = Right Hand Riser Location

Digits 30 — Riser Type

0 = No Riser
L = Type L Riser
M = Type M Riser

Digits 31 — Supply Riser

0 = No Riser
B = 1-inch Riser with Insulation
C = 1.25-inch Riser with Insulation
D = 1.5-inch Riser with Insulation
E = 2-inch Riser with Insulation
F = 2.5-inch Riser with Insulation
G = 3-inch Riser with Insulation
2 = 1-inch Riser
3 = 1.25-inch Riser
4 = 1.5-inch Riser
5 = 2-inch Riser
6 = 2.5-inch Riser
7 = 3-inch Riser

Digits 32 — Return Riser

0 = No Riser
B = 1-inch Riser with Insulation
C = 1.25-inch Riser with Insulation
D = 1.5-inch Riser with Insulation
E = 2-inch Riser with Insulation
F = 2.5-inch Riser with Insulation
G = 3-inch Riser with Insulation
2 = 1-inch Riser
3 = 1.25-inch Riser
4 = 1.5-inch Riser
5 = 2-inch Riser
6 = 2.5-inch Riser
7 = 3-inch Riser

Digits 33 — Condensate Riser

0 = No Riser
B = 1-inch Riser with Insulation
C = 1.25-inch Riser with Insulation
D = 1.5-inch Riser with Insulation
E = 2-inch Riser with Insulation
F = 2.5-inch Riser with Insulation
G = 3-inch Riser with Insulation
2 = 1-inch Riser
3 = 1.25-inch Riser
4 = 1.5-inch Riser
5 = 2-inch Riser
6 = 2.5-inch Riser
7 = 3-inch Riser

Digits 34, 35, 36 — Riser Length

000 = No Riser
096 = 96-inch Riser Length
097 = 97-inch Riser Length
098 = 98-inch Riser Length
099 = 99-inch Riser Length
100 = 100-inch Riser Length
101 = 101-inch Riser Length
102 = 102-inch Riser Length
103 = 103-inch Riser Length
104 = 104-inch Riser Length
105 = 105-inch Riser Length
106 = 106-inch Riser Length
107 = 107-inch Riser Length
108 = 108-inch Riser Length
109 = 109-inch Riser Length
110 = 110-inch Riser Length
111 = 111-inch Riser Length
112 = 112-inch Riser Length
113 = 113-inch Riser Length
114 = 114-inch Riser Length
115 = 115-inch Riser Length
116 = 116-inch Riser Length
117 = 117-inch Riser Length
118 = 118-inch Riser Length
119 = 119-inch Riser Length
120 = 120-inch Riser Length



Model Number Description

Vertical High-Rise Chassis WSHP

Digits 1, 2, 3 — Unit Configuration

GET = High Efficiency Vertical High Rise Heat Pump

Digit 4 — Development Sequence

K = R-454B

Digits 5, 6, 7 — Nominal Size (Tons)

009 = 0.75 Tons

012 = 1 Tons

015 = 1.25 Tons

018 = 1.5 Tons

024 = 2 Tons

036 = 3 Tons

Digit 8 — Voltage (Volts/Hz/Phase)

1 = 208/60/1

2 = 230/60/1

7 = 265/60/1

Digit 9 — Heat Exchanger

1 = Copper Water Coil

2 = Cupro-Nickel Water Coil

3 = Copper Water Coil with Isolation Valve and Low Flow Control

4 = Cupro- Nickel Water Coil with Isolation Valve and Low Flow Control

5 = Copper Water Coil with Isolation Valve and High Flow Control

6 = Cupro-Nickel Water Coil with Isolation Valve and High Flow Control

Digit 10 — Current Design Sequence

Digit 11 — Refrigeration Circuit

0 = Heating and Cooling Circuit

Digit 12 — Blower Configuration

1 = Free Discharge (Factory Wire Low Speed) - PSC motor

2 = Ducted (Factory Wire Hi Speed) - PSC motor

3 = Free Discharge with 1-inch Flange - PSC motor

4 = Free Discharge with 3-inch Flange - PSC motor

5 = ECM without Flange

6 = ECM with 1-inch Flange

7 = ECM with 3-inch Flange

8 = Chassis only/No Motor (ECM Control)

9 = Chassis only/No Motor (PSC Control)

Digit 13 — Freeze Protection¹

A = 20°F Freezestat (For Glycol loop)

B = 35°F Freezestat (For Water loop)

Digit 14 — Open Digit

0 = Open

Digit 15 — Supply-Air Arrangement

0 = Field Cut Supply Air Arrangement

1 = Back and Front Supply Air Arrangement

2 = Back and Left Supply Air Arrangement

3 = Back and Right Supply Air Arrangement

4 = Front and Left Supply Air Arrangement

5 = Front and Right Supply Air Arrangement

6 = Left and Right Supply Air Arrangement

7 = Back, Front and Right Supply Air Arrangement

8 = Back, Front and Left Supply Air Arrangement

9 = Front, Right and Left Supply Air Arrangement

B = Back Supply Air Arrangement

L = Left Supply Air Arrangement

R = Right Supply Air Arrangement

T = Top Supply Air Arrangement

F = Front Supply Air Arrangement

Digit 16 — Return-Air Arrangement

0 = No Door (Chassis Only)

1 = Flush with Wall, Hinged Return Air Door

3 = Hinged Return Air Door, Tamper Resistant (HEX)

4 = Hinged Return Air Door, with Key Lock

Digit 17 — Control Types

0 = Basic Controls for WPRD Retrofit Chassis

D = Deluxe 24 V Controls

H = Symbio™ 400-B

J = Symbio 400-B with Air-Fi® Wireless Communications

Digit 18 — Thermostat Sensor Location

0 = Wall Mounted Location

Digit 19 — Fault Sensors

0 = No Fault Sensors

1 = Condensate Overflow Sensor

2 = Filter Maintenance Timer

3 = Condensate Overflow and Filter Maintenance Timer

Digit 20 — Temperature Sensor

0 = No Additional Temperature Sensors

1 = Entering Water Sensor

Digit 21, 22 — Open Digits

Digit 23 — Unit Mounted Disconnect

0 = No Unit Mounted Switch

C = ON/OFF Switch

D = ON/OFF Switch with Fuses

Digit 24 — Filter Type

1 = 1-inch Throwaway Filter

Digit 25 — Acoustic Arrangement

0 = Enhanced Sound Attenuation

1 = Deluxe Sound Attenuation

Digit 26 — Factory Configuration

2 = GET Chassis

R = WPRD Retrofit Chassis

Digits 27 — Paint Color

9 = Light White Finish

Digits 28 — Outside Air Option

0 = No Outside Air

Digits 29 — Piping Arrangement

B = Back Riser Location

L = Left Hand Riser Location

R = Right Hand Riser Location

Digits 30 — Riser Type

0 = No Riser (Chassis Only)

Digits 31 — Supply Riser

0 = No Riser (Chassis Only)

Digits 32 — Return Riser

0 = No Riser (Chassis Only)

Digits 33 — Condensate Riser

0 = No Riser (Chassis Only)

Digits 34, 35, 36 — Riser Length

000 = No Riser (Chassis Only)

¹ 20°F Freezestat is typically used in a geothermal application. 35°F Freezestat is typically used in a boiler/tower application.



General Information

Blower/Motor

The blower and motor is located inside the unit cabinet. The blower and motor may be removed from the cabinet through the chassis opening. After removing the chassis, the blower assembly is strapped into the unit cabinet through a single metal, flexible bracket. We refer to this bracket as a housing belly bracket. After detaching one screw at the bottom/front edge of the bracket, the housing and motor are free to be lifted from the fan deck.

Compressor Nameplate

The nameplate for the compressors are located on the compressor shell.

Controls

A 75 VA transformer is factory supplied on this unit configuration. See wiring diagram on chassis access panel for field wiring connection to the 24V mechanical thermostat.

Deluxe 24V Controls

Units containing the deluxe 24V control design will incorporate a microprocessor-based control board. The Trane microprocessor board is factory wired to a terminal strip to provide all necessary terminals for field connection. The deluxe board is equipped with a random start relay, anti-short cycle timer, brown out protection, compressor disable, unit safety control, diagnostics and a generic relay (which may be available for field use). See [Table 13, p. 30](#) for diagnostic information.

Power wiring is made at the contactor. The wiring is fed through the left or right conduit tube, and into the cabinet's control box (contactor).

Schrader Connections

Connections for the low and high side of the refrigeration system are located conveniently on the chassis front beneath a sheet metal plate.

Sound Attenuation

Sound attenuation is applied as a standard feature in the product design. The enhanced reduction package includes a heavy gage base plate, and gasket/insulation around the compressor enclosure.

An optional deluxe sound reduction package is also available. It includes a heavy gage base plate, gasket and insulation around the compressor enclosure, and vibration isolation between the chassis and cabinet. An additional

dampening treatment is applied around the compressor enclosure to achieve greater acoustical reductions.

Unit Description

Before shipment, each unit is leak tested, dehydrated, charged with refrigerant and run tested for proper control operation.

Unit Nameplate

The unit nameplate is located at the front of the unit. It includes the unit model number, serial number, electrical characteristics, refrigerant charge, and other pertinent unit data.

Water Connections

1/2-inch or 3/4-inch water connections are located on the chassis's upper section and clearly labeled for water-in/out hose to riser hook-up.

Water-to-Refrigerant Coils

The co-axial water-to-refrigerant heat exchanger for the 0.75 ton through 3 tons equipment is constructed of copper or cupro-nickel (option) for the water section and stainless steel for the refrigeration section.

The heat exchanger is leak tested to assure there is no cross leakage between the water and refrigerant gas.

Symbio™ 400-B

The Symbio™ 400-B is a multi-purpose, programmable (or application-specific) that provides direct digital zone temperature control. This controller can operate as a stand-alone device or as part of a building automation system (BAS). Communication between the controller and a BAS occurs on an open standard with inter-operable protocols used in Building Automation and Control Networks (BACnet®). Programming is done by means of the Tracer TU service tool.

For more information on Symbio 400-B, refer to *Symbio™ 400-B/500 Programmable Controllers Water Source Heat Pump (WSHP) Installation, Operation, and Maintenance (BAS-SVX092*-EN)*.

For more information on the Trane® Air-Fi® wireless system, refer to *Air-Fi® Wireless System Installation, Operation, and Maintenance (BAS-SVX40*-EN)*.



General Information

Operating Limits

Table 1. Operating limits

Operating Limits	Cooling	Heating
Air limits		
Min. ambient air DB	45°F (7°C)	
Max. ambient air DB	130°F (54.4°C)	
Min. EAT DB/WB	65.6/49.4°F (18.7/9.7°C)	48.0°F/- (8.9°C/-)
Max. EAT DB/WB	85.6/77.1°F (29.8/25.1°C)	78.0°F/- (25.6°C/-)
Airflow range	312 to 544 CFM/ton ^(a)	
Water Limits		
Min. entering water temperature	45°F (7°C)	25°F (-4°C)
Max. entering water temperature	120°F (49°C)	86°F (30°C)
Max. water pressure	400 PSIG (2758 kPa)	
Water flow range	1.5 to 3.5 GPM/ton ^(a)	

^(a) See performance tables for each model number for rated values.



Pre-Installation

⚠ WARNING

Fiberglass Wool!

Exposure to glass wool fibers without all necessary PPE equipment could result in cancer, respiratory, skin or eye irritation, which could result in death or serious injury. Disturbing the insulation in this product during installation, maintenance or repair will expose you to airborne particles of glass wool fibers and ceramic fibers known to the state of California to cause cancer through inhalation.

You **MUST** wear all necessary Personal Protective Equipment (PPE) including gloves, eye protection, a NIOSH approved dust/mist respirator, long sleeves and pants when working with products containing fiberglass wool.

Precautionary Measures:

- Avoid breathing fiberglass dust.
- Use a NIOSH approved dust/mist respirator.
- Avoid contact with the skin or eyes. Wear long-sleeved, loose-fitting clothing, gloves, and eye protection.
- Wash clothes separately from other clothing; rinse washer thoroughly.
- Operations such as sawing, blowing, tear-out, and spraying may generate fiber concentrations requiring additional respiratory protection. Use the appropriate NIOSH approved respirator.

First Aid Measures:

- **Eye Contact** - Flush eyes with water to remove dust. If symptoms persist, seek medical attention.
- **Skin Contact** - Wash affected areas gently with soap and warm water after handling.

Jobsite Inspection

Always perform the following checks before accepting a unit:

- Verify that the nameplate data matches the data on the sales order and bill of lading (including electrical data).
- Verify that the power supply complies with the unit nameplate specifications.
- Visually inspect the exterior of the unit, for signs of shipping damage. Do not sign the bill of lading accepting the unit(s) until inspection has been completed. Check for damage promptly after the unit(s) are unloaded. Once the bill of lading is signed at the job site, the unit(s) are now the property of the sold to party and future freight claims may not be accepted by the freight company.

- Verify that the refrigerant charge has been retained during shipment by use of gauges. Schrader taps are located external to the cabinet on the 3/4 to 3 ton equipment.
- After assuring that charge has been retained, reinstall the schrader caps to assure that refrigerant leakage does not occur.

Jobsite Storage

⚠ WARNING

Risk of Fire — Flammable Refrigerant!

Failure to follow instructions below could result in death or serious injury, and equipment damage. The equipment shall be stored in a room without continuously operating ignition sources.

NOTICE

Microbial Growth!

Failure to follow instructions below could result in odors and damage to the equipment and building materials.

Wet interior unit insulation can become an amplification site for microbial growth (mold). If there is evidence of microbial growth on the interior insulation, it should be removed and replaced prior to operating the system.

NOTICE

Microbial Growth!

Failure to follow instructions below could result in odors and damage to the equipment and building materials.

The floor or foundation must be level and the condensate drain at the proper height for proper drainage and condensate flow. Standing water and wet surfaces inside the equipment can become an amplification site for microbial growth (mold). If there is evidence of microbial growth on the interior insulation, it should be removed and replaced prior to operating the system.

This unit is intended for indoor use only. To protect the unit from damage due to the elements, and to prevent possible IAQ contaminant sources from growing, the unit should be stored indoors. If indoor storage is not possible, the following provisions for outdoor storage must be met:

- Place the unit(s) on a dry surface or raise above the ground to assure adequate air circulation beneath the unit.
- Cover the unit(s) with a water proof tarp to protect them from the elements.



Pre-Installation

- Make provisions for continuous venting of the covered units to prevent moisture from standing on the unit(s) surfaces. Wet interior unit insulation can become an amplification site for microbial growth which has been determined to be a cause of odors and serious health related indoor air quality problems.
- Store refrigeration units (chassis) units in the normal UP orientation to maintain oil in the compressor. Cabinet configurations may be stored as crated.
- Do not stack units.

Dimensions and Weights

⚠ WARNING

Improper Unit Lift!

Failure to properly lift unit in a LEVEL position could result in unit dropping and possibly crushing operator/technician which could result in death or serious injury, and equipment or property-only damage.

Test lift unit approximately 24 inches (61 cm) to verify proper center of gravity lift point. To avoid dropping of unit, reposition lifting point if unit is not level.

Table 2. Unit weights

Size	Shipping weight with pallet (lb)	Shipping weight without pallet (lb)
Cabinet		
009	135	115
012	135	115
015	175	150
018	175	150
024	225	195
036	225	195
Chassis		
009	88	78
012	107	97
015	112	102
018	117	107
024	174	164
036	190	180

Unit Location and Clearances

Locate the unit in an indoor area. The ambient temperature surrounding the unit must not be less than 45°F. Do not locate the unit in areas subject to freezing.

Attention should be given to service clearance and technician safety. The unit chassis should be easily removed from the cabinet in all applications. There must be enough space for service personnel to perform maintenance or repair. Provide sufficient room to make water, and electrical connection(s). Local and national codes should be followed in providing electrical power connections.

Figure 1. Mechanical clearances

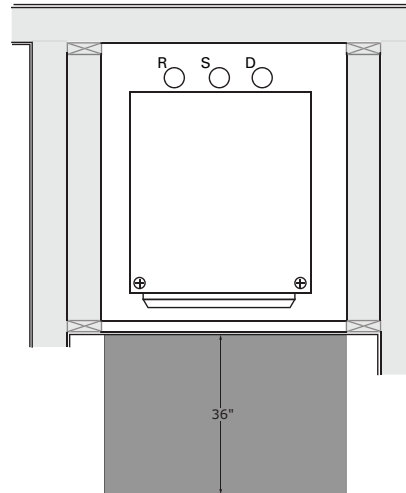

Note: Clearance shown is at unit front for chassis removal.



Dimensions and Weights

Dimensions and Weights with Standard Base

Figure 2. GET009-036

TOP

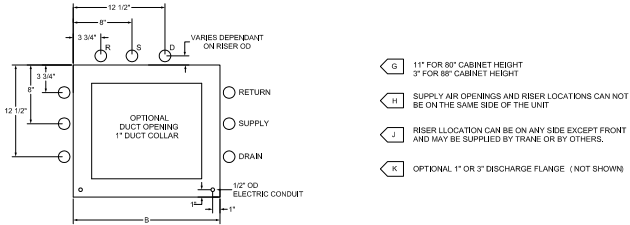

- G 1 1/2" FOR 80" CABINET HEIGHT
3" FOR 88" CABINET HEIGHT
- H SUPPLY AIR OPENINGS AND RISER LOCATIONS CAN NOT BE ON THE SAME SIDE OF THE UNIT
- J RISER LOCATION CAN BE ON ANY SIDE EXCEPT FRONT AND MAY BE SUPPLIED BY TRANE OR BY OTHERS.
- K OPTIONAL 1" OR 3" DISCHARGE FLANGE (NOT SHOWN)

FRONT

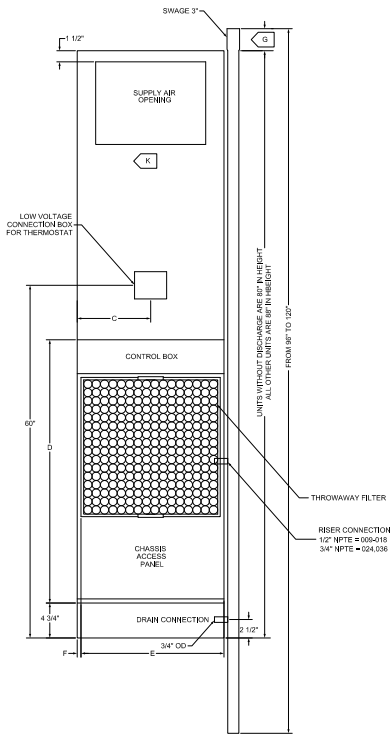

RIGHT SIDE

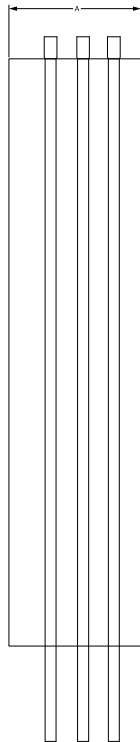

Table 3. Dimensional data - GET009-036 w/standard base

GET	A (inches)	B (inches)	C (inches)	D (inches)	E (inches)	F (inches)
009-012	16 1/4	16 1/4	8 1/8	39 1/8	14 3/4	3/4
015-018	18	20	10	40 5/8	18 3/4	3/4
024-036	24	24	12	49 5/8	22 5/8	3/4

Dimensions and Weights with 6-inch Extended Base

Figure 3. GET009-036

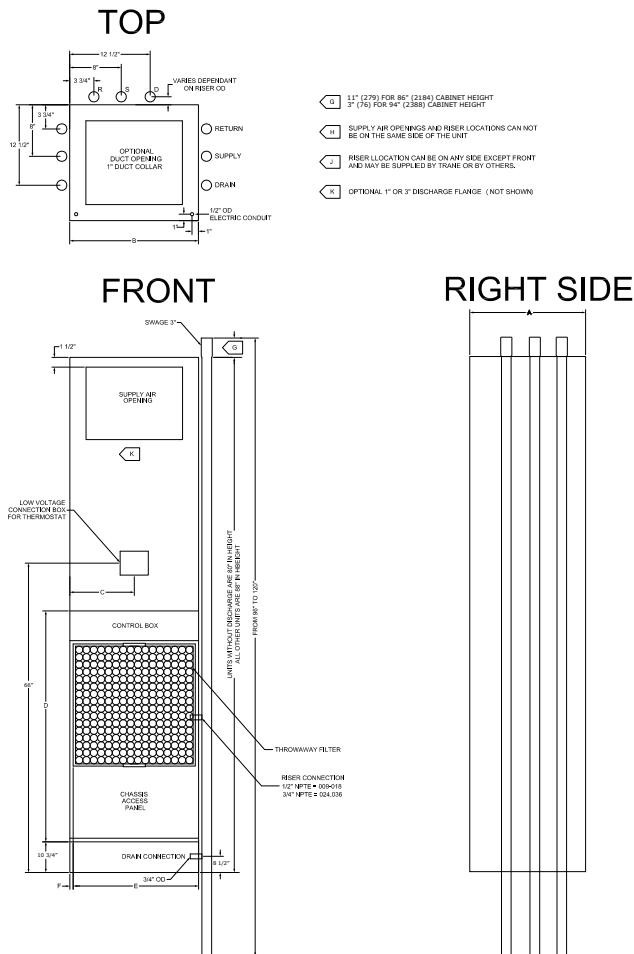

Table 4. Dimensional data - GET009-036 with 6-inch extended base

GET	A (inches)	B (inches)	C (inches)	D (inches)	E (inches)	F (inches)
009-012	16 1/4	16 1/4	8 1/8	39 1/8	14 3/4	3/4
015-018	18	20	10	40 5/8	18 3/4	3/4
024-036	24	24	12	49 5/8	22 5/8	3/4

Return Air (Hinged) Acoustical Door with Standard Base

The hinged acoustical door is recessed into the wall so that the door is flush with the surface of the wall.

The opening through the wall for the door assembly must be centered with the return-air opening of the unit cabinet. For full installing instructions of the return-air acoustical door, see "Units Utilizing Hinged Acoustic Door Assembly," p. 26.

Figure 4. Return air (hinged) acoustical door with standard base

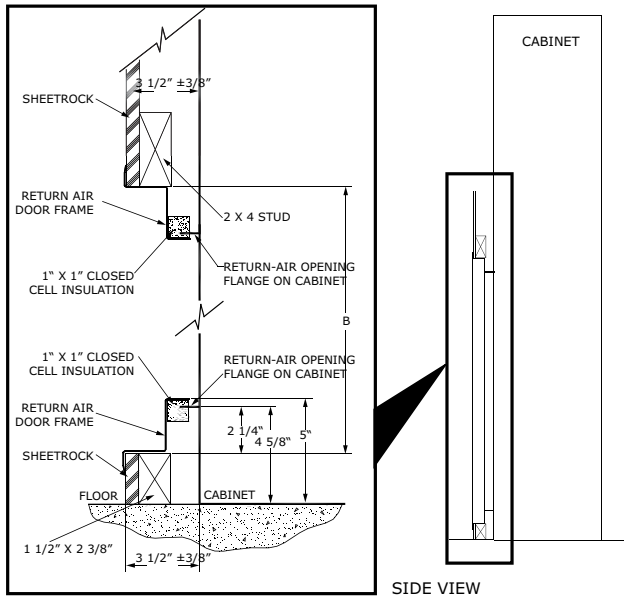
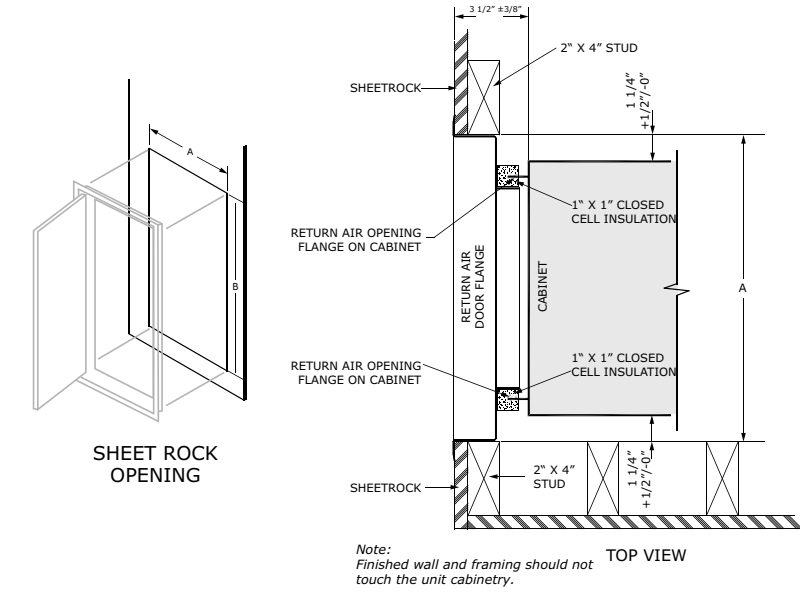

Table 5. Return air hinged acoustical door

Unit Size	A (inches)	B (inches)
009-012	19 1/4	44 1/8
015-018	23 1/4	45 1/4
024-036	27 1/8	54 5/8

Return Air (Hinged) Acoustical Door with 6-inch Extended Base

The hinged acoustical door is recessed into the wall so that the door is flush with the surface of the wall.

The opening through the wall for the door assembly must be centered with the return-air opening of the unit cabinet. For full installing instructions of the return-air acoustical door, see “Units Utilizing Hinged Acoustic Door Assembly,” p. 26.

Figure 5. Return air (hinged) acoustical door with 6 inches extended base

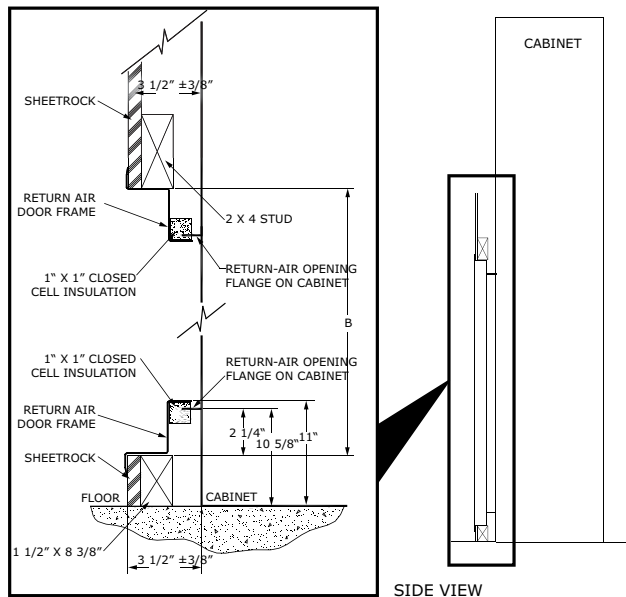
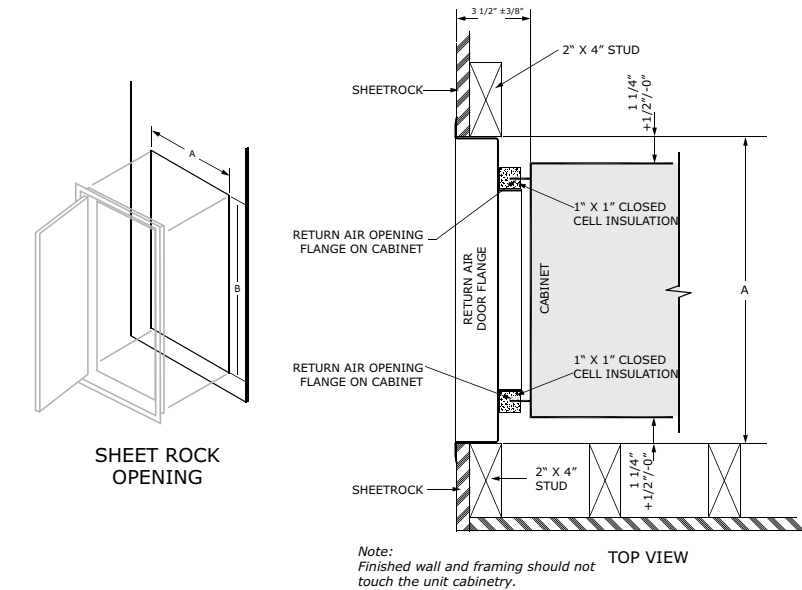

Table 6. Return air hinged acoustical door with 6-inch extended base

Unit Size	A (inches)	B (inches)
009-012	19 1/4	44 1/8
015-018	23 1/4	45 1/4
024-036	27 1/8	54 5/8



A2L Information and Installation Requirements

Installation/Code Compliance Requirements

Building level controls may need to be upgraded/modified to demand leak mitigation actions as described in “[Leak Detection System](#) (Refrigerant charge greater than 3.91 lb per circuit),” p. 22. Those actions include, but are not limited to, fully opening damper and VAV boxes (if present), and disabling electric heat in VAV boxes (if present).

Verify the equipment refrigerant charge is in accordance with the room area limitation as described in Minimum Room Area Limits section.

Ensure that there are labels on the equipment stating it contains a flammable refrigerant.

A2L Work Procedures

⚠ WARNING

Risk of Fire — Flammable Refrigerant!

Failure to follow instructions below could result in death or serious injury, and equipment damage.

- To be repaired only by trained service personnel.
- Do not puncture refrigerant tubing.
- Dispose of properly in accordance with federal or local regulations.
- The equipment shall be stored in a room without continuously operating ignition sources.

⚠ WARNING

Refrigerant under High Pressure!

Failure to follow instructions below could result in an explosion which could result in death or serious injury or equipment damage.

System contains refrigerant under high pressure. Recover refrigerant to relieve pressure before opening the system. See unit nameplate for refrigerant type. Do not use non-approved refrigerants, refrigerant substitutes, or refrigerant additives.

⚠ WARNING

Hazardous Voltage!

Failure to disconnect power before servicing could result in death or serious injury.

Disconnect all electric power, including remote disconnects before servicing. Follow proper lockout/tagout procedures to ensure the power can not be inadvertently energized. Verify that no power is present with a voltmeter.

The units described in this manual use R-454B refrigerant. Use ONLY R-454B rated service equipment or components with these units. For specific handling concerns with R-454B, contact your local Trane representative.

Installation, repair, removal, or disposal should be performed by trained service personnel.

At all times, Trane’s maintenance and service guidelines shall be followed. If in doubt, contact Trane technical support for assistance.

Servicing

Prior to initiating work on equipment, check the area with an appropriate refrigerant detector. Ensure the service personnel are properly trained regarding work in potentially toxic or flammable atmospheres. Ensure that the leak detection equipment being used is suitable for use with all applicable refrigerants, i.e. non-sparking, adequately sealed, or intrinsically safe. Be aware that the refrigerant does not contain an odor.

If any hot work is to be conducted on the refrigerating equipment or any associated parts, appropriate fire extinguishing equipment shall be available on hand. A dry powder or CO₂ fire extinguisher should be located adjacent to the charging area.

At all times, Trane’s maintenance and service guidelines shall be followed. If in doubt, contact Trane technical support for assistance.

All maintenance staff and others working in the local area shall be instructed on the nature of the work being carried out. Work in confined spaces shall be avoided.

Ignition Source Mitigation

Do not use any sources of ignition when working on the refrigeration system.

Keep all ignition sources, including cigarette smoking, away from the site of installation, repair, removal or disposal, during which refrigerant can potentially be released to the surrounding space.

Survey the area around the equipment before initiating work to ensure no flammable hazards or ignition risks are present.

“No Smoking” signs shall be displayed.

Do not use devices that can be a source of ignition to accelerate defrosting of components. Use only defrost and cleaning procedures recommended by Trane. Do not pierce or burn.

Ventilation

Ensure that the area is in the open or that it is adequately ventilated before breaking into the system or conducting any hot work. A degree of ventilation shall continue during the period that the work is carried out. The ventilation should safely disperse any released refrigerant and preferably expel it externally into the atmosphere. If present, check that the ventilation system, including outlets, are operating adequately and are not obstructed.

Refrigerating Equipment

Refrigerant piping or components should not be installed in locations where substances which may corrode them are present.

Check that equipment hazard markings are visible and legible. Replace them if they are not.

For equipment using secondary fluids, like water or glycol, check that refrigerant is not present in the secondary fluid loop before conducting any hot work.

Electrical Devices

Do not apply power to the circuit if a fault exists which compromises safety. If the fault cannot be corrected immediately, but it is necessary to continue operation, an adequate temporary solution shall be used. This shall be reported to the owner of the equipment, so all parties are advised.

Initial safety checks shall include:

- Cabling is not subject to wear, corrosion, excessive pressure, vibration, sharp edges, or any other adverse environmental effects. Account for the effects of aging or continual vibration from sources such as compressors or fans.
- Capacitors are discharged. This shall be done in a safe manner to avoid possibility of sparking.
- No live electrical components and wiring are exposed while charging, recovering, or purging the system.
- Verify continuity of earth bonding.
- Replace electrical components with Trane replacement parts, or those meeting the same ratings and qualified for flame arrest protection, UL LZGH2 category.

Leak Detection

Never use an open flame to detect leaks. A halide torch should not be used. Use only approved leak detection methods per this instruction manual.

The following leak detection methods are deemed acceptable for all refrigerant systems.

Electronic leak detectors may be used to detect refrigerant leaks but, in the case of flammable refrigerants, the sensitivity may not be adequate, or may need re-

calibration. (Detection equipment shall be calibrated in a refrigerant-free area.) Ensure that the detector is not a potential source of ignition and is suitable for the refrigerant used. Leak detection equipment shall be set at a percentage of the LFL gas (25% maximum) is confirmed.

Leak detection fluids are also suitable for use with most refrigerants but the use of detergents containing chlorine shall be avoided as the chlorine may react with the refrigerant and corrode the copper pipe-work.

Examples of leak detection fluids are:

- Bubble method
- Fluorescent method agents

If a leak is suspected, all naked flames shall be removed/ extinguished.

If a refrigerant leak is found which requires brazing, all refrigerant shall be recovered from the system, or isolated (by means of shut off valves) in a part of the system remote from the leak.

Refrigerant Removal and Evacuation

Ensure that the correct number of cylinders for holding the total system charge is available. All cylinders to be used are designated for the recovered refrigerant and labeled for that refrigerant (special cylinders for the recovery of refrigerant, for example). Cylinders shall be complete with pressure-relief valve and associated shut-off valves in good working order. Empty recovery cylinders are evacuated and, if possible, cooled before recovery occurs.

When breaking into the refrigerant circuit to make repairs – or for any other purpose – conventional procedures shall be used. However, for flammable refrigerants it is important that best practice be followed, since flammability is a consideration.

The following procedure shall be adhered to:

1. Safely remove refrigerant following local and national regulations.
2. Evacuate.
3. Purge the circuit with inert gas.
4. Evacuate (optional for A2L).
5. Continuously flush or purge with inert gas when using flame to open circuit.
6. Open the circuit.

Prior to refrigerant removal, open all appropriate valves, including solenoid and electronic expansion valves (EXVs). Use control settings, where available. When not available, manually open all electronically controlled valves using acceptable service procedures.

The recovery equipment shall be in good working order with instructions available. Equipment shall be suitable for the recovery of the flammable refrigerant. For specific handling concerns, contact the manufacturer. Ensure all hose connections are checked for tightness to avoid refrigerant leaks.



A2L Information and Installation Requirements

In addition, a set of calibrated weighing scales shall be available and in good working order.

The refrigerant shall be recovered into the correct recovery cylinders if venting is not allowed by local and national codes. Do not mix refrigerants in recovery unit and especially not in cylinders.

Refrigerant recovery unit should be purged with an inert gas after each use or before using with a different refrigerant Class – for example, A2L to A1.

If compressors or compressor oils are to be removed, ensure that they have been evacuated to an acceptable level to make certain that flammable refrigerant does not remain within the lubricant. The compressor body shall not be heated by an open flame or other ignition sources to accelerate this process. When oil is drained from a system, it shall be carried out safely.

The system shall be purged with oxygen-free nitrogen to render the appliance safe for flammable refrigerants. This process might need to be repeated several times. Compressed air or oxygen shall not be used for purging refrigerant systems.

The system shall be vented down to atmospheric pressure to enable work to take place.

The outlet for the vacuum pump shall not be close to any potential ignition sources, and ventilation shall be available.

Refrigerant Charging

In addition to conventional charging procedures, the following requirements shall be followed.

- Ensure that contamination of different refrigerants does not occur when using charging equipment.
- Hoses or lines shall be as short as possible to minimize the amount of refrigerant contained in them.
- Cylinders shall be kept in an appropriate position according to the instructions.
- Ensure that the refrigerating system is earthed prior to charging the system with refrigerant.
- Label the system when charging is complete (if not already).
- Extreme care shall be taken not to overfill the refrigerating system.

Prior to recharging the system, it shall be pressure-tested with the appropriate purging gas. The system shall be leak-tested on completion of charging but prior to commissioning. A follow up leak test shall be carried out prior to leaving the site.

Prior to refrigerant charging, open all appropriate valves, including solenoid and electronic expansion valves (EXVs). Use control settings, where available. When not available, manually open all electronically controlled valves using acceptable service procedures.

Verify the equipment refrigerant charge is in accordance with the room area limitation as described in Minimum Room Area Limits section.

Decommissioning

Before carrying out the decommissioning procedure, it is essential that the trained service personnel is completely familiar with the equipment and all its details. It is recommended good practice that all refrigerants are recovered safely. Prior to the task being carried out, an oil and refrigerant sample shall be taken in case analysis is required prior to re-use of recovered refrigerant. It is essential that electrical power is available before the task is commenced.

1. Become familiar with the equipment and its operation.
2. Isolate system electrically.
3. Before attempting the procedure, ensure that:
 - a. Mechanical handling equipment is available, if required, for handling refrigerant cylinders.
 - b. All personal protective equipment is available and being used correctly.
 - c. The recovery process is supervised at all times by a competent person.
 - d. Recovery equipment and cylinders conform to the appropriate standards.
4. Pump down refrigerant system, if possible.
5. If a vacuum is not possible, make a manifold so that refrigerant can be removed from various parts of the system.
6. Make sure that cylinder is situated on the scales before recovery takes place.
7. Start the recovery machine and operate in accordance with instructions.
8. Do not overfill cylinders (no more than 80% volume liquid charge).
9. Do not exceed the maximum working pressure of the cylinder, even temporarily.
10. When the cylinders have been filled correctly and the process completed, make sure that the cylinders and the equipment are removed from site promptly and all isolation valves on the equipment are closed off.
11. Recovered refrigerant shall not be charged into another refrigerating system unless it has been cleaned and checked.
12. When equipment has been decommissioned, attach a signed and dated label stating it has been decommissioned and emptied of refrigerant.
13. Ensure that there are labels on the equipment stating it contains flammable refrigerant.

A2L Application Considerations

This product is listed to UL standard 60335-2-40, Household and Similar Electrical Appliances – Safety – Part 2-40: Particular Requirements for Electrical Heat Pumps, Air-Conditioners and Dehumidifiers, which defines safe design and use strategies for equipment using A2L

refrigerants. This standard limits the refrigerant concentration in a space in the event of a refrigerant leak. To meet the requirements, the UL standard defines minimum room area, refrigerant charge limit, minimum circulation airflow and/or ventilation airflow requirements, and limits the use of ignition sources in spaces. The standard may require a unit refrigerant leak detection system.

For equipment with R-454B and charge amounts less than or equal to 3.91 lbs per circuit, this UL standard does not prescribe a room area limit and does not require a refrigerant leak detection system or any circulation airflow or ventilation airflow mitigation strategies. However, ignition sources in ductwork must be evaluated.

Depending on the application, a specific requirement of ANSI/ASHRAE Standard 15, Safety Standard for Refrigeration Systems, could be more stringent than UL 60335-2-40 requirements. See *Refrigeration Systems and Machinery Rooms Application Considerations for Compliance with ASHRAE® Standard 15-2022 Application Engineering Manual* (APP-APM001*-EN) for more information.

Ignition Sources in Ductwork

Do not install open flames in the ductwork. Hot surfaces exceeding 700°C (1290°F) should not be installed in the ductwork unless the average airflow velocity is not less than 1.0 m/s (200 ft/min) across the heater and proof of airflow is verified before system is energized.

Electric heaters can exceed the surface temperature limit if airflow distribution is poor, or insufficient airflow is provided over the heater.

Surface temperatures of most gas heaters do not exceed the surface temperature limits due to ANSI construction requirements.

Ignition Sources in Unit

This unit does not contain any ignition sources. All potential ignition sources, (including factory or field installed accessory electric heaters, gas heaters, relays, and contactors) were evaluated during product UL listing.

Minimum Room Area Limits (Refrigerant charge greater than 3.91 lb per circuit)

Equipment with R-454B charge amounts greater than 3.91 lb per circuit may require additional circulation or ventilation airflow mitigation strategies. In this case, two minimum room area (A_{min}) thresholds:

- The first threshold defines when equipment serving a single room is required to provide circulation airflow, either continuous or activated by a leak detection system. A ducted system requires circulation airflow unless the smallest room it serves is larger than the adjusted A_{min} threshold. This product contains a leak detection system if a circuit charge is greater than 3.91 lbs. As a result, no further leak detection system evaluation is required.
- The second threshold defines when additional ventilation airflow is required. If the room area, A or TA , is below the adjusted A_{min} or TA_{min} threshold, additional ventilation is required to remove refrigerant in the event of a leak. Refer to UL 60335-2-40 Clause GG.8 and ANSI/ASHRAE Standard 15 Section 7 for natural and mechanical ventilation requirements.

Table 7. Minimum room area — GETK

Models	A_{min} (GG.7DV) (m ²) 0.6 meters height	A_{min} (GG.7DV) (ft ²) 1.94 feet height
GETK009	8	81
GETK012	9	95
GETK015	11	120
GETK018	11	117
GETK024	13	145
GETK036	19	203

Minimum Room Area (A_{min}) Adjustments

Use equation below to adjust the minimum room area, as applicable, based on the unit's installation height, altitude, and occupancy level it serves.

$$A_{min.adj} = \text{Nameplate } A_{min} \times \text{Altitude Adj} \times \text{Height Adj} \times F_{occ}$$

Multiply the altitude adjustment factor in the table below by A_{min} listed on the unit nameplate or in the Installation, Operation, and Maintenance (IOM) manual.

A2L Information and Installation Requirements

Table 8. Altitude adjustment factor

Altitude (ft)	Sea Level to 2000	2001 to 4000	4001 to 6000	6001 to 8000	8001 to 10000	10001 to 12000	12001 to 14000	14001 to 15000	Over 15000
A_{min} Adjustment	1	1.05	1.11	1.17	1.24	1.32	1.41	1.51	1.57

In addition, A_{min} can be adjusted if the unit is installed in a room at a height that is higher than the minimum height shown on the unit. To adjust A_{min} , multiply by the ratio of the unit minimum release height (in meters) / actual release height (in meters). Use 0.6 m in the ratio for unit minimum installation heights less than or equal to 0.6 m.

For institutional occupancies, ASHRAE Standard 15 applies an additional adjustment factor F_{occ} to the amount of a charge allowed in a space. To calculate the adjusted A_{min} for institutional occupancies, multiply the A_{min} on the nameplate by two.

EXAMPLE 1: 20 Ton Packaged Rooftop Multi-Zone VAV System Serving an Institutional Occupancy Space

The packaged unit serves 7600 ft² of a nursing home located at an altitude of 4000 ft. The unit has two equally charged 10 ton refrigeration circuits. Each circuit has 12 lbs of refrigerant with a minimum room area requirement of 180 ft² with a 2.2 m release height.

$$TA_{min.adj} = 180 \text{ ft}^2 \times 1.05 \times 2 = 378 \text{ ft}^2$$

No additional ventilation is required.

EXAMPLE 2: 10 Ton Split System Serving a Single Commercial Occupancy Space

The split system serves a 1500 ft² manufacturing space at 5000 ft altitude. The final installed charge of the single circuit 10 ton unit is 20 lb. The unit has an open return with a release height of 1 m and ducted supply air. The unit A_{min} is 660 ft².

$$A_{min.adj} = 660 \text{ ft}^2 \times 1.11 = 733 \text{ ft}^2$$

No additional ventilation is required.

Determining Room Area (A or TA)

The room area (A) is the room area enclosed by the projection to the floor of the walls, partitions, and doors of the space that the equipment serves. For ducted systems, total room area (TA) of all rooms connected by ducts, may be used instead of A.

Rooms connected by drop ceilings only are not considered a single room.

Rooms on the same floor of the building, and connected by an open passageway, can be considered part of the same room if the passageway is a permanent opening, extends to the floor and is intended for people to walk through.

Adjacent rooms on the same floor of the building and connected by permanent openings in the walls and/or doors between rooms (including gaps between the wall and the floor), can be considered part of the same room if the openings meet the following criteria.

- The opening is permanent and cannot be closed.
- Openings extending to the floor, such as door gaps, need to be at least 20 mm above the floor covering surface.
- Natural ventilations opening areas must meet the requirements of ANSIASHRAE Standard 15-2022, Section 7.2.3.2.

Rooms that are connected by a mechanical ventilation system can be considered a single room area if the mechanical ventilation system meets the requirements of ANSIASHRAE Standard 15-2022, Section 7.6.4.

Leak Detection System (Refrigerant charge greater than 3.91 lb per circuit)

The leak detection system consists of one or more refrigerant detection sensors. When the system detects a leak, the following mitigation actions will be initiated until refrigerant has not been detected for at least 5 minutes:

- Energize the supply fan(s) to deliver a required minimum amount of circulation airflow.
- Disable compressor operation.
- Provide an output signal that can be used to fully open zone dampers and/or VAV boxes and disable electric heat in VAV boxes.
- Provide an output signal that can be used to energize additional mechanical ventilation (if needed).
- Units without airflow proving will disable electric heat sources.

Building fire and smoke systems may override this function.

If the refrigerant sensor has a fault, is at the end of its life, or is disconnected, the unit will initiate the mitigation actions. Mitigation actions may be verified by disconnecting the sensor.

The refrigerant sensors do not need service. Use only manufacturer-approved sensors when replacement is required.



Installation

General Installation Checks

The checklist below is a summary of the steps required to successfully install a commercial unit. This checklist is intended to acquaint the installing personnel with the installation process. It does not replace the detailed instructions in the applicable sections of this manual.

1. Remove packaging and inspect the unit. Check the unit for shipping damage and material shortage; file a freight claim and notify appropriate sales representation.

Notes:

- *The unit cabinet is packaged in a wooden crate. A pry bar and/or hammer will be needed for packaging removal.*
- *The chassis sits inside a cardboard tray with an upper box for protection. Typically four chassis will be shrinkwrapped to a single pallet.*

2. Verify the correct model, options, and voltage from the unit nameplate.
3. Verify the installation location of the unit provides required clearance for proper operation.
4. Remove refrigeration access panel and inspect the unit. Be certain the refrigerant tubing has clearance from adjacent parts.

Main Electrical

⚠ WARNING

Hazardous Voltage!

Failure to disconnect power before servicing could result in death or serious injury.

Disconnect all electric power, including remote disconnects before servicing. Follow proper lockout/tagout procedures to ensure the power can not be inadvertently energized. Verify that no power is present with a voltmeter.

⚠ WARNING

Proper Field Wiring and Grounding Required!

Failure to follow code could result in death or serious injury.

All field wiring **MUST** be performed by qualified personnel. Improperly installed and grounded field wiring poses **FIRE** and **ELECTROCUTION** hazards. To avoid these hazards, you **MUST** follow requirements for field wiring installation and grounding as described in NEC and your local/state/national electrical codes.

1. Verify the power supply complies with the unit nameplate specifications.
2. Inspect all control panel components; tighten any loose connections.
3. Connect properly sized and protected power supply wiring to a field-supplied/installed disconnect switch and to the unit power block (1TB1) in the unit's cabinet control box for equipment.
4. Install proper grounding wires to an earth ground.

Note: All field-installed wiring must comply with NEC and applicable local codes.

Low Voltage Wiring (AC and DC) Requirements

Connect properly sized control wiring to the proper termination points between the field supplied thermostat and the terminal plug in the equipment's junction box.

Unit Placement

⚠ WARNING

Improper Unit Lift!

Failure to properly lift unit in a **LEVEL** position could result in unit dropping and possibly crushing operator/technician which could result in death or serious injury, and equipment or property-only damage.

Test lift unit approximately 24 inches (61 cm) to verify proper center of gravity lift point. To avoid dropping of unit, reposition lifting point if unit is not level.

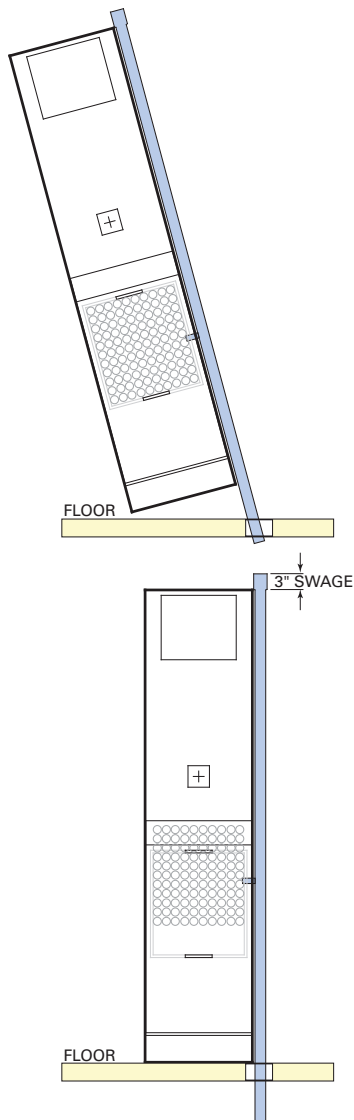
Figure 6. Stacking illustration

If unit cabinet assembly includes factory provided risers, and no field provided between-the-floor riser extensions, please move to [Step 1](#).

Note: *Risers are designed to accommodate a maximum of 1 1/2-inch to 3-inch expansion and contraction. If the total calculated riser expansion exceeds 3-inch, expansion devices must be field provided.*

If unit cabinet assembly includes factory provided risers and field provided between-the-floor riser extensions are required, install the extensions before installing the cabinet.

1. Install drain valve, shut-off/balancing valves, flow indicators and drain at the base of each supply and return riser to enable system flushing at start-up, balancing and service/maintenance.
2. Lift cabinet into space while aligning it into the 3-inch swage of the riser below.

Note: *Take extra care as not to scrape or dent risers during positioning. The riser should fall approximately 2-inch into the 3-inch swage. This will allow for the variation in floor-to-floor dimensions, and keep the riser joints from bottoming out.*

3. Level the cabinet.
4. Plumb risers in two planes to assure proper unit operation and condensate drainage.
5. Anchor all units into place.
6. For field provided risers, center the supply/return stubouts into the unit expansion slots. The stubouts should be perpendicular to the cabinet panel.
7. Verify all risers are vertical and that they penetrate the swaged joint at least 1-inch. Riser should not be allowed to bottom out.
8. Braze riser joints. Soft solder or low-temperature alloys should not be used in this application.
9. If risers are field provided, it is recommended that the risers be anchored to the building structure with a minimum of one contact point. For expansion and contraction reasons, do not fasten risers rigidly to the building.
10. Seal access holes made through the cabinet for piping with suitable material to help eliminate air leakage.
11. See [“Cleaning and Flushing the Water Loop,”](#) p. 28 for system flushing.

Note: *Remove shipping straps from risers.*

Water Connection

For vibration isolation, it is recommended that flexible steel braided hoses be installed instead of hard piping between the vertical risers and the unit chassis.

Refer to *Hose Kit Accessories Automatic and Manual Balancing Product Catalog* (WSHP-PRC025*-EN) for hose kit variations.

Note: *Two foot hose kit and ball valves are recommended for 009 - 018 size units. Three foot hose kit and ball valves are recommended for 024 - 036 size units.*

Field Installed Power Wiring

⚠ WARNING

Proper Field Wiring and Grounding Required!

Failure to follow code could result in death or serious injury.

All field wiring **MUST** be performed by qualified personnel. Improperly installed and grounded field wiring poses **FIRE** and **ELECTROCUTION** hazards. To avoid these hazards, you **MUST** follow requirements for field wiring installation and grounding as described in NEC and your local/state/national electrical codes.

Verify that the power supply available is compatible with the units nameplate. Use only copper conductors to connect the power supply to the unit.

NOTICE

Use Copper Conductors Only!

Failure to use copper conductors could result in equipment damage as the equipment was not designed or qualified to accept other types of conductors.

Main Unit Power Wiring

⚠ WARNING

Hazardous Voltage!

Failure to disconnect power before servicing could result in death or serious injury.

Disconnect all electric power, including remote disconnects before servicing. Follow proper lockout/tagout procedures to ensure the power can not be inadvertently energized. Verify that no power is present with a voltmeter.

A field supplied disconnect switch must be installed at or near the unit in accordance with the National Electric Code (NEC latest edition).

Location of the applicable electric service entrance for HIGH (line voltage) may be found in [Figure 7, p. 25](#).

Figure 7. Power wire entrance



Route power wire to the cabinet control box through the factory installed conduit at the top of the unit cabinetry. The high voltage connection is made at the 1PB1 power block in the cabinet control box. Refer to the customer connection diagram that is shipped with the unit for specific termination points.

Provide proper grounding for the unit in accordance with the local and national codes.

Control Power Transformer

⚠ WARNING

Hazardous Voltage!

Failure to disconnect power before servicing could result in death or serious injury.

Disconnect all electric power, including remote disconnects before servicing. Follow proper lockout/tagout procedures to ensure the power can not be inadvertently energized. Verify that no power is present with a voltmeter.

The 24V control power transformers are to be used only with the accessories called out in this manual. Transformers rated greater than 75 VA are equipped with internal circuit breakers. If a circuit breaker trips, turn off all power to the unit before attempting to reset it.

The transformer is located in the chassis control box.

Drywall Installation

Before installing drywall around cabinet, cover the cabinet supply and return openings with plastic or cardboard to help prevent dust or construction debris from reaching unit components. Warranties will be voided if paint or foreign debris is allowed to contaminate internal unit components. The location of the drywall may be dependent upon the type of return air access design. For units containing a field provided return air access assembly, the contractor must calculate location of drywall to allow for frame mounting

Units Utilizing Hinged Acoustic Door Assembly

Figure 8. Mock-up of stud placement



1. Locate the side studs a minimum of 1 1/4-inches and a maximum of 1 3/8-inches from the cabinet to the side of the stud. This critical dimension, combined with distance between studs is used to determine the side-to-side opening for the door, dimension A. The distances provided in the table are a minimum dimension. Allow 3 1/2-inches from the front of the cabinet to the sheet rock surface, Figure 9, p. 26 - top view, Figure 8, p. 26.
2. The height of the door assembly must be positioned to recess the door 2 1/4-inches from the cabinet's return-air opening, reference drywall installation for hinged acoustic door - side view blow up.

Figure 9. Drywall installation for hinged acoustic door

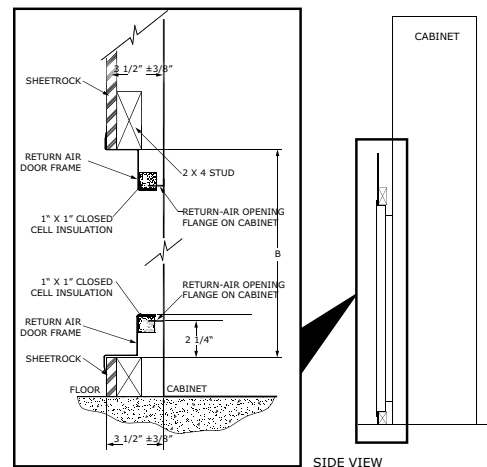
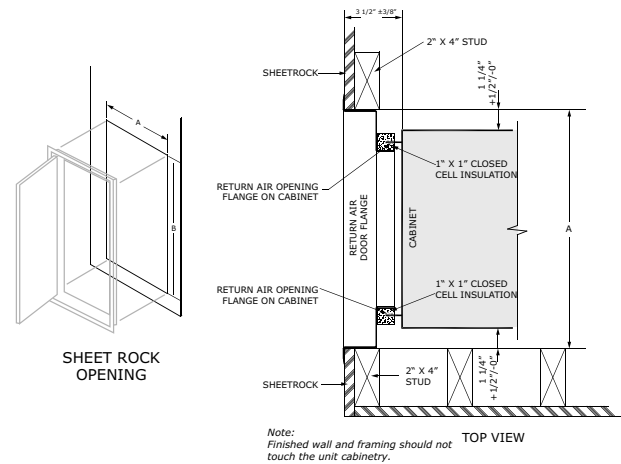

3. Locate dimensions A and B for sheet rock opening size. The position of the sheet rock opening must be centered side-to-side with the return-air opening in the cabinet. Ensure the bottom of the sheet rock opening is 2 1/4-inches below the return-air opening in the cabinet. This allows the door recess to rest on the bottom of the sheet rock opening for proper vertical placement of the door.

Table 9. Sheet rock opening size

Unit Size	A (inches)	B (inches)
009-012	19 1/4	44 1/8
015-018	23 1/4	45 1/4
024-036	27 1/8	54 5/8

4. Place the door frame into the sheet rock opening. A positive seal is critical between the back of the door frame and the front of the cabinet. Ensure that the gasket material seals properly.

Note: When placing the sheet rock panel, make certain the opening for the door is centered with the return-air opening in the cabinet ($\pm 1/8$ -inches).

- Secure the door frame to the side studs using the holes located in the door frame and field provided screws.

Note: If the gap between the door frame, and the side stud is over 1/16-inch, place a shim in between the door frame and the stud to prevent the door frame from bending/ denting.

Figure 10. Door opening



- Place the air panel into the door opening. The gasket on the back side of the air panel should seal around the coil perimeter.

Note: If return air doors or grills are not installed, field will be required to seal gaps between cabinet and filter door.

Figure 11. Air panel gasket



- After verifying that the air panel gasket is sealed to the coil, secure the air panel to the door frame using the slots located on the sides of the air panel.

Figure 12. Secure to door frame



- Install filter.

- Vacuum all dust and construction debris from unit after cutting out supply/return openings.

Supply Air Ductwork

A 2-inch duct flange may be required to help eliminate supply air from recirculating back into the return air, air-to-refrigerant coil prior to discharging into the space.

Equipment containing a top discharge, ducted design: install field ductwork to the unit providing a water tight flexible connector at the unit. This helps prevent operating sounds from transmitting through the ductwork. Elbows with turning vanes or splitters are recommended to minimize air noise due to turbulence and to help reduce static pressure.

Chassis Installation

- Remove three 18-inch bolts on the chassis and discard.
- Rotate the triangular metal plate to cover the bolt holes in the chassis. Secure with two sheet metal screws.

Figure 13. Shipping bolts (see arrows)

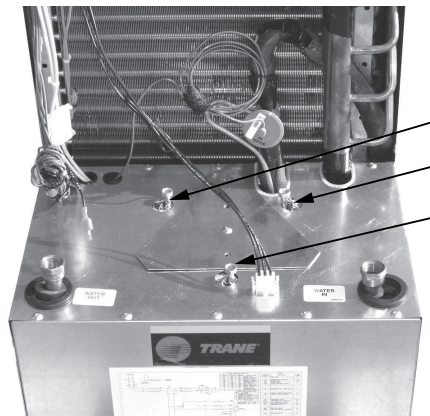

Note: Not all units will include shipping bolts.

- Remove one shipping bracket (one on each side) attached to the chassis slide rails and discard.

Note: Remove this bracket only if the deluxe sound package design is selected.

Figure 14. Bracket removal for deluxe sound package

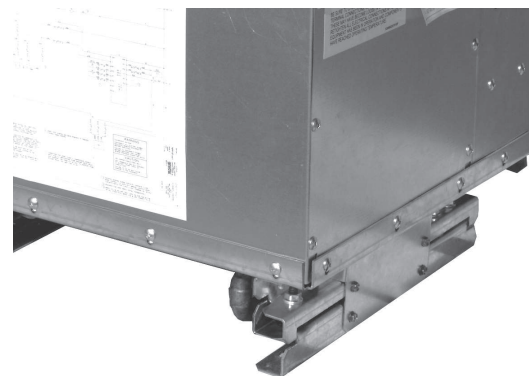

4. Connect water coil pipe to the system riser with a flexible steel hose assembly.
5. Verify that the shut-off/balancing valve in the return line/ supply line are closed.
6. Place shut-off valves in appropriate location (see sticker on the equipment for best placement recommendation) to allow chassis to slide easily in/out of unit cabinet.
7. Flush the system using the cleaning and flushing the water loop instructions.
8. Open the unit water valves and check piping for leaks.
9. Connect electrical to unit chassis via the quick connect mating plugs.

Notes:

- *Four plugs are included (motor, optional condensate overflow, power and thermostat).*
- *On units utilizing 400-B controls, locate discharge air sensor coiled behind chassis control box and affix sensor bulb near the intake of the blower housing in the cabinet.*

10. Slide chassis into the cabinet. Center the chassis left to right to minimize sound transmission.

Figure 15. Install chassis centered



11. Verify units air filter has shipped with the cabinet.
12. Install cabinets front cover to the hinged door.

Important: *Confirm the gasket material creates a positive seal around the entire coil to avoid coil bypass. If a field supplied door is used, ensure the front cover is attached to the building structure and not the unit cabinet.*

Supply Grille Installation

Table 10. Supply air opening size

GET	Single Grille 100% CFM (inches)	Two Grille 50% CFM (inches)	Three Grille 33% CFM (inches)	Top Discharge up to 100% CFM (inches)
009-012	14 W x 14 H	10 W x 6 H	Not Recommended	14 W x 10 H
015-018	16 W x 12 H	14 W x 12 H	12 W x 8 H	16 W x 14 H
024	22 W x 18 H	14 W x 12 H	12 W x 8 H	16 W x 14 H
036	Not Recommended	16 W x 14 H	14 W x 12 H	17 W x 17 H

1. Install the supply grille(s) into the cabinet discharge opening. Ensure there are no air gaps between the cabinet supply air and the grille. This helps prevent recirculation of supply air into the return air opening behind the drywall.
2. Secure grille(s) into the drywall via two screws.

Cleaning and Flushing the Water Loop

After the piping system is complete, the flexible hose connectors should be doubled back to complete the water circuit external to the unit (avoiding trash settle-out in the condenser). An extra pipe may be necessary to connect the hose kits. See "Using Antifreeze," p. 29 for antifreeze/ water mixture by volume.

1. Water circulation system should be filled with clean water using the water make up connections.
Note: *Air vents should be opened during filling.*
2. With the air vents closed, start the circulating pump and then crack the air vents to bleed off the trapped air, assuring circulation through all components of the system.

Notes:

- *Make up water must be available to the system to replace the volume formerly occupied by the air that is bled off.*
 - *System water pressure needs to be relieved prior to opening system.*
3. With the air vented and the water circulating, the entire system should be checked for leaks with repairs made as required.
 4. Operate the supplementary heat system making checks per manufacturer's instructions. During this operation, visual checks should be made for leaks that may have occurred due to increased heat. Repair as required.
 5. Open the system at the lowest point for the initial blow down (making sure the make up water is equal to the

water being dumped). Continue blow down until the water leaving the drain runs clear, but not less than 2 hours.

- Shutdown pumps and supplementary heat system. Reconnect the hoses placing the water-to-refrigerant heat exchanger in the water circulating system.

Note: Vents should be open when the pumps and supplementary heat system are shut down.

Figure 16. Flushing the water loop

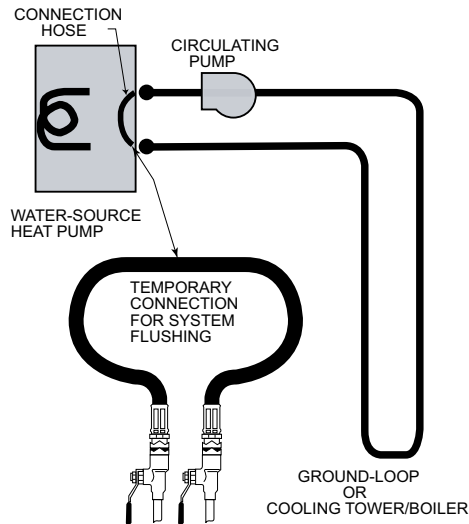

Using Antifreeze

In areas of the country where entering water temperatures drop below 45°F or where piping is being run through areas subject to freezing, the loop must be freeze protected by using an approved antifreeze solution to prevent the earth loop water from freezing inside the heat exchanger. Methanol and glycols are the most commonly used antifreeze solutions. Consult your geothermal unit supplier for locally approved solutions in your area.

Propylene glycol is not recommended in installations where the water temperature are expected to fall below 30°F. At extreme temperatures, the viscosity increases to the point where normal loop circulating pumps may not maintain proper flow.

If propylene glycol is the only locally approved solution for antifreeze, good engineering practices should be used to achieve the desired flow.

Calculate the approximate volume of water in the system by using the requirements detailed in the [Table 22, p. 39, Water Volume](#). Add three gallons to this total to allow for the water contained in the hose kit and geothermal unit.

Table 11. Antifreeze requirements based on volume

Type of Antifreeze	Minimum Temperature for Freeze Protection				
	10°F	15°F	20°F	25°F	30°F
Methanol	25%	21%	16%	10%	3%
Propylene Glycol	—	—	—	—	6%

Low Voltage Wiring

Factory ordered thermostats and zone sensors are pre-wired with a quick connecting plug.

- After installing the cabinet assembly, simply plug the external portion of thermostat/zone sensor plug into the internal portion of the plug located inside the unit's junction box.
- Mount the thermostat, zone sensor or Trane® Air-Fi® WCI module on the finished drywall.

Thermostat/zone sensor connection shown below in the zone sensor connection figure.

Low Voltage Wiring for Field Provided Thermostats/Zone Sensors

Ensure that the AC control wiring between the controls and the unit's termination point does not exceed three (3) ohms/conductor for the length of the run.

NOTICE

Component Failure!

Resistance in excess of 3 ohms per conductor could result in component failure due to insufficient AC voltage supply.

Do not exceed three (3) ohms per conductor for the length of the run.

Check all loads and conductors for grounds, shorts, and mis-wiring.

Do not run the AC low voltage wiring in the same conduit with the high voltage power wiring.

Table 12. 24V AC conductors

Distance from unit to Control	Recommended Wire Size
000-460 feet	18 gauge
461-732 feet	16 gauge
733-1000 feet	14 gauge

Figure 17. Zone sensor connection

Six (6) Pin Connector/Harness

- Red = 24V
- Black = Fan
- Orange = RV
- Yellow = Compressor
- Blue = Common

Table 13. Deluxe controller diagnostic LEDs

Color: Green	Color: Red		Controller Mode
	LED2	LED3	
LED1	LED2	LED3	
OFF	OFF	OFF	Control OFF
ON	OFF	OFF	Normal/Compressor OFF
ON	OFF	FLASH	Anti-short Cycle
ON	OFF	ON	Normal/Compressor ON
FLASH	ON	OFF	Brownout Condition
ON	FLASH	ON	Soft Lockout (low pressure)
ON	FLASH	FLASH	Soft Lockout (high pressure)
ON	ON	ON	Manual Lockout (low pressure)
ON	ON	FLASH	Manual Lockout (high pressure)

Table 13. Deluxe controller diagnostic LEDs (continued)

Color: Green	Color: Red		Controller Mode
	LED2	LED3	
LED1	LED2	LED3	
ON	FLASH	OFF	Manual Lockout (condensate overflow)
ON	ON	OFF	Compressor Disable

PSC Blower Motor Speed Retrofit

PSC motors installed in the unit have multiple speed configurations. To modify the rpm of the motor, the following steps may be followed.

⚠ WARNING

Hazardous Voltage!

Failure to disconnect power before servicing could result in death or serious injury.

Disconnect all electric power, including remote disconnects before servicing. Follow proper lockout/tagout procedures to ensure the power can not be inadvertently energized. Verify that no power is present with a voltmeter.

1. Locate the blower motor relay inside the chassis control box.
2. Remove the undesired speed tap.
3. Select desired speed tap wire by using information from [Table 14, p. 30](#).
4. Connect desired tap wire to the 1K4 relay at spade 4.
5. Reconnect power to the unit.

Table 14. Lead change

Lead Colors		
Lead Speed	High	Low
Blower	1G	9A

ECM CFM Settings

To adjust the CFM, disconnect the power to the unit. Set the DIP switch located in the control box to the desired profile setting. Connect the power to the unit.

Figure 18. Units with Deluxe 24V controls and ECM motors – DIP switch settings

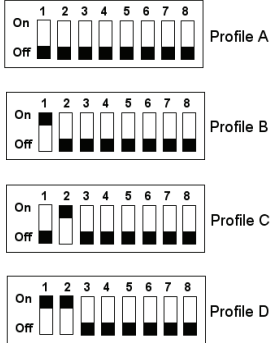
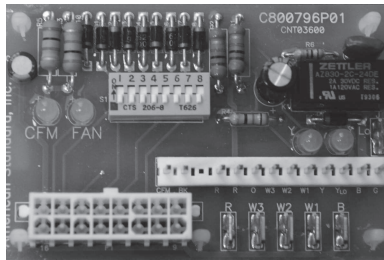

Note: Units with the optional ECM with deluxe 24V controls are shipped from the factory on Profile B.

- Profile A = 110% of rated airflow
- Profile B = 100% of rated airflow
- Profile C = 90% of rated airflow
- Profile D = 80% of rated airflow

Installation at higher altitudes may require an adjustment to the fan speed setting to achieve proper airflow. Use profile C or D to get lower airflow. If a lower CFM is needed, then set DIP switch 4 to ON.

Figure 19. Units with Symbio™ 400-B controls and ECM motors – DIP switch settings

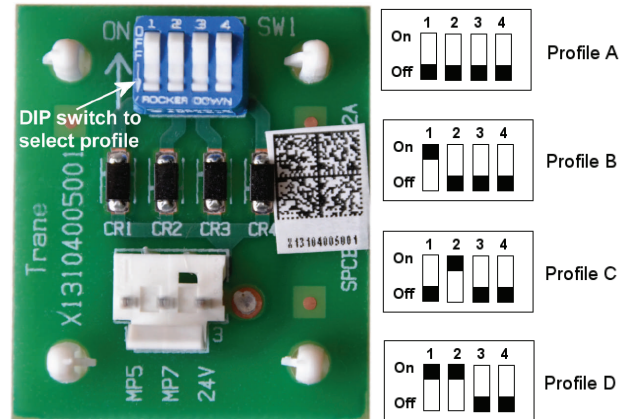

Installations at altitudes above 2000 feet may require an adjustment to the fan speed setting to achieve the proper airflow. To adjust the airflow to get the desired CFM, set the DIP switches located in the control box to the proper profile setting. Tracer® TU can be used to make further adjustments to the fan speed.

Use the following table to select the correct profile to use.

Table 15. Profiles for altitude range

Profile	Altitude (Feet)
A	0–2000
B	2000–4000
C	4000–6000
D	Above 6000

Table 16. PSC blower motor external static pressure without return air door (RAD) with filter

Model	External Static Pressure (in. of wg)																					
	Speed Tap	Ducted Unit ^(a)	CFM		0.00		0.05		0.10		0.15		0.20		0.25		0.30		0.35		0.40	
			Max	Min	CFM	KW	CFM	KW	CFM	KW	CFM	KW	CFM	KW	CFM	KW	CFM	KW	CFM	KW	CFM	KW
GET009	High	Yes	408	-	421	0.108	388	0.107	354	0.106	320	0.104	283	0.103	244	0.102	-	-	-	-	-	-
	Low	Yes	-	-	355	0.073	332	0.072	307	0.070	278	0.068	245	0.067	-	-	-	-	-	-	-	-
	High	No	-	-	357	0.073	333	0.071	309	0.070	282	0.069	253	0.067	-	-	-	-	-	-	-	-
	Low	No	-	272	307	0.061	297	0.06	280	0.059	258	0.058	-	-	-	-	-	-	-	-	-	-
GET012	High	Yes	453	-	453	0.140	433	0.137	412	0.134	390	0.130	367	0.127	342	0.124	316	0.121	288	0.118	-	-
	Low	Yes	-	-	401	0.112	383	0.109	362	0.106	340	0.103	318	0.100	295	0.097	-	-	-	-	-	-
	High	No	-	-	418	0.125	400	0.122	379	0.120	356	0.117	332	0.113	309	0.110	286	0.107	-	-	-	-
	Low	No	-	304	345	0.097	331	0.095	313	0.092	292	0.090	-	-	-	-	-	-	-	-	-	-



Installation

Table 16. PSC blower motor external static pressure without return air door (RAD) with filter (continued)

Model	External Static Pressure (in. of wg)																					
	Speed Tap	Ducted Unit ^(a)	CFM		0.00		0.05		0.10		0.15		0.20		0.25		0.30		0.35		0.40	
			Max	Min	CFM	KW	CFM	KW	CFM	KW	CFM	KW	CFM	KW	CFM	KW	CFM	KW	CFM	KW	CFM	KW
GET015	High	Yes	648	-	-	-	-	-	652	0.191	634	0.187	616	0.183	598	0.179	579	0.175	558	0.17	535	0.165
	Low	Yes	-	-	560	0.155	539	0.153	523	0.152	511	0.149	499	0.146	487	0.143	472	0.139	455	0.135	433	0.13
	High	No	-	-	553	0.169	538	0.167	524	0.165	510	0.162	496	0.159	481	0.155	464	0.151	444	0.147	421	0.142
	Low	No	-	432	445	0.135	433	0.135	422	0.134	-	-	-	-	-	-	-	-	-	-	-	-
GET018	High	Yes	780	-	-	-	-	-	-	-	-	-	-	-	-	-	-	-	785	0.330	758	0.323
	Low	Yes	-	-	665	0.253	644	0.249	625	0.246	608	0.242	592	0.237	575	0.232	556	0.227	537	0.221	517	0.215
	High	No	-	-	696	0.361	675	0.354	654	0.348	632	0.342	610	0.336	588	0.33	566	0.324	544	0.318	521	0.312
	Low	No	-	520	544	0.271	526	0.266	506	0.262	-	-	-	-	-	-	-	-	-	-	-	-
GET024	High	Yes	984	-	-	-	-	-	-	-	-	-	-	-	988	0.402	955	0.392	920	0.382	884	0.371
	Low	Yes	-	-	908	0.344	895	0.335	876	0.327	854	0.318	829	0.31	803	0.301	778	0.293	754	0.285	732	0.277
	High	No	-	-	850	0.317	827	0.310	806	0.303	787	0.297	768	0.291	750	0.286	730	0.280	710	0.274	689	0.267
	Low	No	-	656	799	0.292	781	0.286	764	0.280	746	0.275	727	0.269	709	0.264	690	0.258	671	0.252	651	0.246
GET036	High	Yes	1404	-	-	-	-	-	-	-	-	-	-	-	-	-	1420	0.686	1396	0.674	1371	0.662
	Low	Yes	-	-	1303	0.651	1293	0.638	1282	0.625	1270	0.614	1256	0.603	1240	0.592	1222	0.582	1202	0.572	1181	0.562
	High	No	-	-	1330	0.642	1304	0.630	1277	0.618	1248	0.606	1219	0.593	1188	0.581	1155	0.568	1122	0.555	1086	0.542
	Low	No	-	936	1059	0.523	1051	0.516	1042	0.510	1033	0.503	1022	0.496	1011	0.488	998	0.480	984	0.472	967	0.464
Model	External Static Pressure (in. of wg)																					
	Speed Tap	Ducted Unit ^(a)	CFM		0.45		0.50		0.55		0.60		0.65		0.70		0.75		0.80		0.85	
			Max	Min	CFM	KW	CFM	KW	CFM	KW	CFM	KW	CFM	KW	CFM	KW	CFM	KW	CFM	KW	CFM	KW
GET009	High	Yes	408	-	-	-	-	-	-	-	-	-	-	-	-	-	-	-	-	-	-	-
	Low	Yes	-	-	-	-	-	-	-	-	-	-	-	-	-	-	-	-	-	-	-	-
	High	No	-	-	-	-	-	-	-	-	-	-	-	-	-	-	-	-	-	-	-	-
	Low	No	-	272	-	-	-	-	-	-	-	-	-	-	-	-	-	-	-	-	-	-
GET012	High	Yes	453	-	-	-	-	-	-	-	-	-	-	-	-	-	-	-	-	-	-	-
	Low	Yes	-	-	-	-	-	-	-	-	-	-	-	-	-	-	-	-	-	-	-	-
	High	No	-	-	-	-	-	-	-	-	-	-	-	-	-	-	-	-	-	-	-	-
	Low	No	-	304	-	-	-	-	-	-	-	-	-	-	-	-	-	-	-	-	-	-
GET015	High	Yes	648	-	510	0.160	480	0.154	445	0.148	404	0.141	-	-	-	-	-	-	-	-	-	-
	Low	Yes	-	-	405	0.125	-	-	-	-	-	-	-	-	-	-	-	-	-	-	-	-
	High	No	-	-	-	-	-	-	-	-	-	-	-	-	-	-	-	-	-	-	-	-
	Low	No	-	432	-	-	-	-	-	-	-	-	-	-	-	-	-	-	-	-	-	-
GET018	High	Yes	780	-	729	0.317	697	0.311	661	0.305	620	0.300	573	0.295	518	0.291	-	-	-	-	-	-
	Low	Yes	-	-	-	-	-	-	-	-	-	-	-	-	-	-	-	-	-	-	-	-
	High	No	-	-	497	0.305	-	-	-	-	-	-	-	-	-	-	-	-	-	-	-	-
	Low	No	-	520	-	-	-	-	-	-	-	-	-	-	-	-	-	-	-	-	-	-
GET024	High	Yes	984	-	847	0.359	810	0.348	774	0.336	739	0.324	706	0.312	676	0.299	649	0.287	-	-	-	-
	Low	Yes	-	-	712	0.268	693	0.260	675	0.251	658	0.243	641	0.234	-	-	-	-	-	-	-	-
	High	No	-	-	666	0.26	642	0.251	-	-	-	-	-	-	-	-	-	-	-	-	-	-
	Low	No	-	656	-	-	-	-	-	-	-	-	-	-	-	-	-	-	-	-	-	-
GET036	High	Yes	1404	-	1346	0.65	1320	0.638	1293	0.625	1265	0.613	1236	0.601	1206	0.588	1175	0.575	1142	0.563	1107	0.550
	Low	Yes	-	-	1160	0.553	1138	0.543	1117	0.533	1097	0.522	1076	0.511	1055	0.498	1031	0.486	1003	0.472	967	0.456
	High	No	-	-	1048	0.528	1007	0.515	965	0.501	919	0.487	-	-	-	-	-	-	-	-	-	-
	Low	No	-	936	949	0.454	927	0.444	-	-	-	-	-	-	-	-	-	-	-	-	-	-

Table 16. PSC blower motor external static pressure without return air door (RAD) with filter (continued)

Model	External Static Pressure (in. of wg)													
	Speed Tap	Ducted Unit	CFM		0.90		0.95		1.00		1.05		1.10	
			Max	Min	CFM	KW	CFM	KW	CFM	KW	CFM	KW	CFM	KW
GET009	High	Yes	408	-	-	-	-	-	-	-	-	-	-	-
	Low	Yes	-	-	-	-	-	-	-	-	-	-	-	-
	High	No	-	-	-	-	-	-	-	-	-	-	-	-
	Low	No	-	272	-	-	-	-	-	-	-	-	-	-
GET012	High	Yes	453	-	-	-	-	-	-	-	-	-	-	-
	Low	Yes	-	-	-	-	-	-	-	-	-	-	-	-
	High	No	-	-	-	-	-	-	-	-	-	-	-	-
	Low	No	-	304	-	-	-	-	-	-	-	-	-	-
GET015	High	Yes	648	-	-	-	-	-	-	-	-	-	-	-
	Low	Yes	-	-	-	-	-	-	-	-	-	-	-	-
	High	No	-	-	-	-	-	-	-	-	-	-	-	-
	Low	No	-	432	-	-	-	-	-	-	-	-	-	-
GET018	High	Yes	780	-	-	-	-	-	-	-	-	-	-	-
	Low	Yes	-	-	-	-	-	-	-	-	-	-	-	-
	High	No	-	-	-	-	-	-	-	-	-	-	-	-
	Low	No	-	520	-	-	-	-	-	-	-	-	-	-
GET024	High	Yes	984	-	-	-	-	-	-	-	-	-	-	-
	Low	Yes	-	-	-	-	-	-	-	-	-	-	-	-
	High	No	-	-	-	-	-	-	-	-	-	-	-	-
	Low	No	-	656	-	-	-	-	-	-	-	-	-	-
GET036	High	Yes	1404	-	1071	0.536	1032	0.523	991	0.509	947	0.495	900	0.481
	Low	Yes	-	-	919	0.440	-	-	-	-	-	-	-	-
	High	No	-	-	-	-	-	-	-	-	-	-	-	-
	Low	No	-	936	-	-	-	-	-	-	-	-	-	-

^(a) The NO Ducted option is for non-ducted (free return) units. Units specified as non-ducted (free return) are factory wired to low-speed. Units specified as ducted are factory wired to high-speed.

Table 17. ECM Blower motor external static pressure without return air door (RAD) with filter

Model No.	Airflow Profile	External Static Pressure (in. of wg)															
		CFM	0.00 kW	0.05 kW	0.10 kW	0.15 kW	0.20 kW	0.25 kW	0.30 kW	0.35 kW	0.40 kW	0.45 kW	0.50 kW	0.55 kW	0.60 kW	0.65 kW	0.70 kW
		GET009	A	374	0.025	0.037	0.050	0.062	0.075	0.087	0.098	0.110	0.121	0.133	0.144	0.037	0.165
B	344		0.023	0.035	0.046	0.057	0.068	0.079	0.090	0.100	0.110	0.120	0.130	0.035	0.149	0.159	0.159
C	313		0.021	0.032	0.042	0.052	0.062	0.071	0.081	0.090	0.099	0.108	0.117	0.032	0.134	0.143	0.143
D	285		0.017	0.027	0.036	0.045	0.054	0.063	0.071	0.080	0.088	0.096	0.104	0.027	0.120	0.127	0.127
GET012	A	487	0.027	0.042	0.057	0.071	0.086	0.100	0.114	0.128	0.142	0.155	0.168	0.042	0.193	0.206	0.206
	B	442	0.025	0.038	0.052	0.065	0.077	0.090	0.103	0.115	0.127	0.139	0.151	0.038	0.173	0.184	0.184
	C	403	0.023	0.034	0.046	0.057	0.069	0.080	0.091	0.102	0.112	0.122	0.133	0.034	0.152	0.161	0.161
	D	368	0.019	0.029	0.039	0.049	0.059	0.068	0.078	0.087	0.096	0.105	0.114	0.029	0.131	0.139	0.139
GET015	A	594	0.062	0.072	0.081	0.090	0.100	0.109	0.119	0.128	0.138	0.148	0.158	0.072	0.179	0.191	0.202
	B	540	0.044	0.054	0.064	0.073	0.083	0.092	0.101	0.111	0.121	0.131	0.141	0.054	0.162	0.173	0.185
	C	486	0.032	0.042	0.051	0.060	0.069	0.079	0.088	0.097	0.106	0.116	0.126	0.042	0.146	0.157	0.168
	D	432	0.025	0.034	0.042	0.051	0.059	0.068	0.076	0.085	0.093	0.102	0.111	0.034	0.130	0.140	0.150



Installation

Table 17. ECM Blower motor external static pressure without return air door (RAD) with filter (continued)

Model No.	Airflow Profile	External Static Pressure (in. of wg)															
			0.00	0.05	0.10	0.15	0.20	0.25	0.30	0.35	0.40	0.45	0.50	0.55	0.60	0.65	0.70
		CFM	kW	kW	kW	kW	kW	kW	kW	kW	kW	kW	kW	kW	kW	kW	kW
GET018	A	712	0.097	0.109	0.121	0.134	0.148	0.163	0.178	0.193	0.208	0.223	0.239	0.109	0.130	0.140	0.150
	B	648	0.077	0.087	0.098	0.110	0.123	0.136	0.150	0.163	0.177	0.191	0.205	0.087	0.268	0.282	0.282
	C	584	0.056	0.066	0.076	0.087	0.099	0.111	0.123	0.135	0.148	0.160	0.172	0.066	0.230	0.242	0.242
	D	522	0.039	0.048	0.058	0.069	0.080	0.091	0.102	0.114	0.125	0.136	0.147	0.048	0.194	0.204	0.204
GET024	A	903	0.100	0.118	0.135	0.152	0.168	0.185	0.201	0.216	0.232	0.247	0.261	0.118	0.290	0.303	0.303
	B	827	0.081	0.096	0.111	0.125	0.140	0.154	0.168	0.182	0.196	0.209	0.222	0.096	0.248	0.261	0.261
	C	746	0.060	0.073	0.085	0.098	0.110	0.123	0.136	0.148	0.161	0.173	0.185	0.073	0.210	0.222	0.222
	D	659	0.041	0.052	0.063	0.074	0.085	0.097	0.109	0.121	0.133	0.145	0.157	0.052	0.182	0.194	0.194
GET036	A	1293	0.285	0.306	0.328	0.349	0.370	0.392	0.413	0.433	0.454	0.475	0.496	0.306	0.537	0.557	0.557
	B	1178	0.214	0.233	0.253	0.272	0.292	0.311	0.330	0.349	0.369	0.388	0.406	0.233	0.444	0.463	0.463
	C	1063	0.158	0.175	0.193	0.210	0.227	0.245	0.262	0.279	0.296	0.313	0.331	0.175	0.365	0.382	0.382
	D	950	0.117	0.133	0.148	0.163	0.178	0.193	0.208	0.223	0.238	0.254	0.269	0.133	0.299	0.314	0.314

Note: The ECM is programmed for constant CFM. The CFM is factory set on Profile B. The ECM reduces the airflow to 80% in fan only mode for additional energy savings.

Table 18. Pressure drop due to return air door (RAD)

Model	CFM	DP	CFM	DP	CFM	DP
GET009	272	0.04	340	0.05	408	0.08
GET012	354	0.06	442	0.10	530	0.16
GET015	432	0.06	540	0.09	648	0.12
GET018	520	0.08	650	0.12	780	0.16
GET024	656	0.06	820	0.08	984	0.12
GET036	936	0.10	1170	0.16	1404	0.23

Note: The pressure drop across the RAD door should be included in the TOTAL ESP when determining airflow and fan motor power usage. If the door is supplied by another vendor, the pressure drop across that door must be included in the TOTAL ESP when determining airflow and fan motor power usage.



Pre-Start-Up

Checklist

Before energizing the unit, the following system devices must be checked:

- Is the high voltage power supply correct and in accordance with the nameplate ratings?
- Is the field wiring and circuit protection the correct size?
- Is the low voltage control circuit wiring correct per the unit wiring diagram?
- Is the piping system clean/complete and correct? (A recommendation of all system flushing of debris from the water-to-refrigerant heat exchanger, along with air purging from the water-to-refrigerant heat exchanger be done in accordance with the Closed-Loop/Ground Source Heat Pump Systems Installation Guide).
- Is vibration isolation provided? (i.e. unit isolation pad, hose kits)
- Is unit serviceable? (See "Unit Location and Clearances," p. 13.)
- Are the low/high-side pressure temperature caps secure and in place?
- Are all the unit access panels secure and in place?
- Is the thermostat in the OFF position?
- Is the water flow established and circulating through all the units?
- Is the duct work (if required) correctly sized, run, taped, insulated and weather proofed with proper unit arrangement?
- Is the condensate line properly sized, run, trapped and pitched?
- Does the indoor blower turn freely without rubbing?
- Has all work been done in accordance with applicable local and national codes?
- Has heat transfer fluid been added in the proper mix to prevent freezing in closed system application?
- Are the compressor bolts removed from the chassis?
- Have the chassis isolation rails been released?
- Is there a good seal between the front air panel and the coil?

Initial Unit Start-Up

Start-up with deluxe controls is included below:

Notes:

- See *Air-Fi® Wireless System Installation, Operation, and Maintenance (BAS-SVX40*-EN)* for Trane® Air-Fi® start-up.
 - See *Symbio™ 400-B/500 Programmable Controllers Water Source Heat Pump (WSHP) Installation, Operation, and Maintenance (BAS-SVX092*-EN)* for Symbio™ 400-B start-up.
1. Set the thermostat to the highest position. Set the thermostat system switch to COOL with the fan control to AUTO. The compressor should NOT run.
 2. Reduce the temperature control setting until the compressor, reversing valve, solenoid valve, and loop pump are energized. Adjust water flow utilizing pressure/temperature plugs and comparing to tables contained in specification sheet data. Water leaving the heat exchanger should be warmer than the entering water temperature (approximately 9°F to 12°F), blower operation should be smooth, compressor and blower amps should be within data plate ratings, the suction line should be cool with no frost observed in the refrigerant circuit.
 3. Check the cooling refrigerant pressures against values in .
 4. Turn the thermostat switch to the OFF position. Unit should stop running and the reversing valve should de-energize.
 5. Leave unit off for approximately 5 minutes to allow for pressure equalization.
 6. Turn the thermostat to the lowest setting. Set the thermostat system switch to the HEAT position.
 7. Adjust the temperature setting upward until the unit is energized. Warm air should blow from the register. A water temperature decrease of approximately 5°F to 9°F leaving the heat exchanger should be noted. The blower and compressor operation should be smooth with no frost observed in the refrigeration circuit.
 8. Check the heating refrigerant pressures against values in .
 9. Set the thermostat to maintain the desired space temperature.
 10. Instruct the owner on system operation.



Operating Pressures

Use the form on “Start-Up Checklist and Log,” p. 40 to log system and unit temperatures during start-up.

General: There are many variables (airflow, air temperatures) in an air conditioning system that will affect operating refrigerant pressures and temperatures. The chart below shows approximate conditions and is based on

airflow at the rated SCFM, entering air at 80.6°F DB, 66.2 °F WB in cooling, 68°F DB in heating. (+)Heating data with 35°F EWT is based on the use of an anti-freeze solution having a freezing point 20°F lower than the minimum expected entering temperature.

Table 19. Operating pressures

Model	Entering Water Temp °F	Water Flow GPM	Operating Data							
			Cooling				Heating			
			Suction Pressure, PSIG	Discharge Pressure, PSIG	Water Temp Rise °F	Air Temp Drop °F DB	Suction Pressure PSIG	Discharge Pressure PSIG	Water Temp Drop °F	Air Temp Rise °F DB
GET*009	35	1.80	-	-	-	-	73-90	260-317	5-6	14-17
GET*009	35	2.25	-	-	-	-	75-92	261-319	4-5	14-17
GET*009	45	1.80	112-137	152-185	11-14	22-27	88-107	275-336	6-8	18-22
GET*009	45	2.25	112-137	146-178	9-11	22-27	90-110	277-338	5-6	18-22
GET*009	55	1.80	114-139	181-222	11-13	22-26	104-128	290-354	7-9	20-25
GET*009	55	2.25	113-139	175-214	9-11	22-26	107-131	292-357	6-7	21-25
GET*009	68	1.80	116-142	214-262	11-13	21-25	124-152	311-380	9-11	24-30
GET*009	68	2.25	116-142	209-256	9-10	21-26	128-157	315-384	7-9	25-30
GET*009	75	1.80	118-144	239-292	10-13	21-25	138-169	323-394	10-12	26-32
GET*009	75	2.25	117-143	233-285	8-10	21-25	143-175	326-399	8-10	27-33
GET*009	86	1.80	119-146	277-339	10-12	20-25	162-198	338-413	11-13	29-35
GET*009	86	2.25	119-146	271-332	8-10	20-25	168-206	341-416	9-11	29-36
GET*009	95	1.80	122-149	307-375	10-12	20-24	-	-	-	-
GET*009	95	2.25	121-148	301-368	8-10	20-24	-	-	-	-
GET*012	35	2.40	-	-	-	-	73-90	228-278	5-6	13-16
GET*012	35	3.00	-	-	-	-	75-92	229-280	4-5	13-16
GET*012	45	2.40	117-143	148-181	12-14	23-28	86-105	238-291	6-7	17-21
GET*012	45	3.00	117-143	143-175	9-12	23-28	88-107	239-293	5-6	17-21
GET*012	55	2.40	118-144	175-214	12-14	22-27	102-125	251-306	7-8	20-24
GET*012	55	3.00	118-144	169-207	9-11	22-27	105-128	253-309	6-7	20-24
GET*012	68	2.40	121-148	211-258	11-14	21-26	116-142	262-320	8-10	22-27
GET*012	68	3.00	120-147	206-251	9-11	22-26	120-146	265-324	6-8	23-28
GET*012	75	2.40	121-147	233-285	11-13	21-26	130-159	272-333	9-11	24-30
GET*012	75	3.00	120-147	227-277	9-11	21-26	134-163	275-337	7-9	25-30
GET*012	86	2.40	124-151	270-330	10-13	21-25	153-187	286-349	10-12	26-32
GET*012	86	3.00	123-151	265-324	8-10	21-25	158-194	288-351	8-10	27-33
GET*012	95	2.40	127-156	297-363	10-12	20-24	-	-	-	-
GET*012	95	3.00	126-154	293-358	8-10	20-24	-	-	-	-
GET*015	35	2.80	-	-	-	-	69-84	237-290	7-8	18-22
GET*015	35	3.80	-	-	-	-	72-87	240-293	5-6	19-23
GET*015	45	2.80	103-126	160-196	12-15	22-27	83-102	255-311	8-9	22-27

Table 19. Operating pressures (continued)

Model	Entering Water Temp °F	Water Flow GPM	Operating Data							
			Cooling				Heating			
			Suction Pressure, PSIG	Discharge Pressure, PSIG	Water Temp Rise °F	Air Temp Drop °F DB	Suction Pressure PSIG	Discharge Pressure PSIG	Water Temp Drop °F	Air Temp Rise °F DB
GET*015	45	3.80	103-125	152-186	9-11	22-27	87-106	258-315	6-7	22-27
GET*015	55	2.80	105-128	191-233	12-15	22-27	99-121	270-330	9-11	25-30
GET*015	55	3.80	104-128	181-222	9-11	22-27	103-126	274-335	7-8	26-31
GET*015	68	2.80	107-131	231-282	12-15	21-26	116-142	288-352	10-13	28-35
GET*015	68	3.80	107-130	222-271	9-11	21-26	122-149	293-358	8-10	30-36
GET*015	75	2.80	111-136	251-306	12-15	22-26	129-158	300-367	11-14	31-38
GET*015	75	3.80	111-136	240-294	9-11	22-26	136-166	306-375	9-11	32-39
GET*015	86	2.80	114-140	289-353	12-15	21-26	151-185	320-392	13-16	34-42
GET*015	86	3.80	114-139	279-341	9-11	21-26	160-196	328-400	10-12	36-43
GET*015	95	2.80	116-142	323-395	12-15	21-25	-	-	-	-
GET*015	95	3.80	116-141	313-382	9-11	21-26	-	-	-	-
GET*018	35	3.60	-	-	-	-	69-85	241-294	6-8	19-23
GET*018	35	4.60	-	-	-	-	72-87	243-297	5-6	19-23
GET*018	45	3.60	100-122	153-187	11-14	22-27	85-103	256-313	7-8	21-26
GET*018	45	4.60	100-122	147-180	9-11	22-27	87-106	258-316	6-7	22-27
GET*018	55	3.60	102-124	182-222	11-14	22-27	101-123	271-332	8-10	24-30
GET*018	55	4.60	101-124	175-214	9-11	22-27	104-127	274-335	6-8	25-30
GET*018	68	3.60	104-127	220-269	11-13	21-26	118-145	289-354	9-11	28-34
GET*018	68	4.60	104-127	214-261	9-11	21-26	123-150	294-359	8-9	29-35
GET*018	75	3.60	109-133	241-294	11-14	21-26	132-161	302-369	10-13	30-37
GET*018	75	4.60	109-133	233-285	9-11	21-26	137-167	306-374	8-10	31-38
GET*018	86	3.60	112-137	279-341	11-14	21-25	155-190	321-392	12-14	33-41
GET*018	86	4.60	112-137	271-332	9-11	21-26	162-198	326-398	9-11	34-42
GET*018	95	3.60	114-140	312-381	11-13	20-25	-	-	-	-
GET*018	95	4.60	114-139	305-372	9-10	21-25	-	-	-	-
GET*024	35	4.70	-	-	-	-	68-84	255-312	6-8	19-23
GET*024	35	6.10	-	-	-	-	71-86	258-315	5-6	19-24
GET*024	45	4.70	102-125	157-192	12-14	23-28	79-96	264-323	7-8	22-27
GET*024	45	6.10	102-125	151-184	9-11	23-28	81-99	267-326	5-7	22-27
GET*024	55	4.70	103-126	184-225	12-14	23-28	94-115	279-341	8-10	24-30
GET*024	55	6.10	103-125	177-217	9-11	23-28	97-119	282-344	6-8	25-31
GET*024	68	4.70	103-126	225-275	11-14	22-27	97-118	282-344	8-10	26-31
GET*024	68	6.10	103-126	217-266	9-11	22-27	101-123	285-349	7-8	26-32
GET*024	75	4.70	111-136	245-300	12-14	22-27	109-133	293-358	9-11	27-34
GET*024	75	6.10	111-136	237-290	9-11	22-27	113-138	296-362	7-9	28-34
GET*024	86	4.70	115-140	284-347	11-14	21-26	130-158	309-378	10-13	30-37
GET*024	81	6.10	115-140	275-337	9-11	22-26	125-153	306-373	8-9	30-36
GET*024	95	4.70	116-142	321-392	11-14	21-26	-	-	-	-



Operating Pressures

Table 19. Operating pressures (continued)

Model	Entering Water Temp °F	Water Flow GPM	Operating Data							
			Cooling				Heating			
			Suction Pressure, PSIG	Discharge Pressure, PSIG	Water Temp Rise °F	Air Temp Drop °F DB	Suction Pressure PSIG	Discharge Pressure PSIG	Water Temp Drop °F	Air Temp Rise °F DB
GET*024	95	6.10	116-141	312-381	9-11	21-26	-	-	-	-
GET*036	35	7.10	-	-	-	-	68-83	251-307	6-7	19-23
GET*036	35	9.10	-	-	-	-	70-86	253-309	5-6	19-24
GET*036	45	7.10	107-131	156-191	12-15	24-29	83-102	269-329	7-8	23-29
GET*036	45	9.10	106-130	150-184	10-12	24-29	86-105	271-332	5-7	24-29
GET*036	55	7.10	109-133	183-223	12-15	23-28	100-122	285-348	8-10	26-32
GET*036	55	9.10	108-132	176-216	9-12	23-29	102-125	287-351	6-8	27-33
GET*036	68	7.10	110-135	223-272	12-15	23-28	117-143	304-371	9-11	30-37
GET*036	68	9.10	109-134	216-264	9-11	23-28	122-149	308-376	7-9	31-38
GET*036	75	7.10	112-137	244-298	12-15	23-28	131-160	316-386	10-12	32-39
GET*036	75	9.10	112-137	236-289	9-11	22-27	136-166	320-391	8-10	33-40
GET*036	86	7.10	114-140	285-349	12-14	22-27	155-189	332-406	11-14	35-43
GET*036	86	9.10	114-139	277-338	9-11	22-27	161-197	335-410	9-11	35-43
GET*036	95	7.10	116-142	324-396	12-14	21-26	-	-	-	-
GET*036	95	9.10	115-141	315-385	9-11	22-26	-	-	-	-

Water Pressure Drop

The following table should be used to define feet of head/pressure drop.

Note: To calculate feet of head, when using gauges that read in PSIG, multiply PSI by 2.31.

Table 20. Water pressure drops (WPD) in feet of head

Unit	GPM	Cooling		Heating	
		EWT °F	Ft. Head Pressure	EWT °F	Ft. Head Pressure
GET*009	1.1	77	1.8	55	2.1
GET*009	2.1	77	5.4	55	6.1
GET*009	2.6	77	7.9	55	8.9
GET*012	1.5	77	4.8	55	5.3
GET*012	2.8	77	14.3	55	15.7
GET*012	3.5	77	21.0	55	23.2
GET*015	1.9	77	2.4	55	2.6
GET*015	3.5	77	7.0	55	7.7

Table 20. Water pressure drops (WPD) in feet of head (continued)

Unit	GPM	Cooling		Heating	
		EWT °F	Ft. Head Pressure	EWT °F	Ft. Head Pressure
GET*015	4.4	77	10.2	55	11.3
GET*018	2.3	77	3.2	55	3.6
GET*018	4.2	77	9.6	55	10.6
GET*018	5.3	77	14.3	55	15.8
GET*024	3.0	77	3.2	55	3.6
GET*024	5.6	77	9.4	55	10.6
GET*024	7.0	77	13.9	55	15.7
GET*036	4.5	77	6.2	55	6.8
GET*036	8.4	77	18.4	55	20.0
GET*036	10.5	77	27.0	55	29.5

Water Volume

The following table is provided for use in calculating glycol requirements for the unit.

Table 21. Model flow option GPM press drop (feet)

Model	Flow Option	GPM	Press Drop (Ft)
GET*009	Low	1.5	6.6
GET*009	High	2.0	8.1
GET*012	Low	2.0	8.1
GET*012	High	2.5	10.1
GET*015	Low	2.5	10.1
GET*015	High	3.5	15.4
GET*018	Low	3.0	12.6
GET*018	High	4.0	18.7
GET*024	Low	4.0	7.6
GET*024	High	6.0	11.4
GET*036	Low	6.0	11.4
GET*036	High	8.0	16.7

Table 22. Water volume

Unit	Water Side Volume Cubic In.	Water Side Volume Cubic Ft.	Water Side Volume Gallons
GET*009	18.7	0.011	0.081
GET*012	24.9	0.014	0.108
GET*015	37.2	0.022	0.161
GET*018	40.9	0.024	0.177
GET*024	62.6	0.036	0.271
GET*036	85.0	0.049	0.368

Flow Checks

For the operating temperature drop (heating) and rise (cooling), refer to for the proper water temperature change. Depending on the unit size, entering water temperature and water flow rate, the cooling temperature rise is from 8°F to 16°F. Based on the same criteria for heating, the temperature drop is from 2°F to 13°F.

Pressure

Using the P/T ports and one 0-60 psi pressure gauge with the P/T port adapter, measure the pressure difference between the water-in and water-out connections. Compare the pressure differential to to determine flow.



Start-Up

Start-Up Checklist and Log

(This form need not be returned to the factory unless requested during technical service support).

Installing Contractor: Use this checklist to thoroughly check-out the system and units before and during start-up.

Job Name:	
Model Number:	
Date:	
Serial Number:	

In order to minimize troubleshooting and costly system failures, complete the following checks and data entries before the system is put into full operation.

MODE	Heat	Heat
Entering fluid temperature	F	F
Leaving fluid temperature	F	F
Temperature differential	F	F
Return-air temperature DB/WB	F	F
Supply-air temperature DB/WB	F	F
Temperature differential	F	F
Water coil heat exchanger (Water Pressure IN)	PSIG	PSIG
Water coil heat exchanger (Water Pressure OUT)	PSIG	PSIG
Pressure Differential	PSIG	PSIG
	PSIG	PSIG
	PSIG	PSIG
COMPRESSOR		
Amps		
Volts		
Discharge line temperature (after 10 minutes)	F	F



Maintenance

Preventive Maintenance

Maintenance on the unit is simplified with the following preventive suggestions:

Filter maintenance must be performed to assure proper operation of the equipment. Filters should be inspected at least every three months, and replaced when it is evident they are dirty. Filter sizing includes:

Table 23. Filter sizing

Model GET	Filter Size (nominal)
009-012	14 x 20
015-018	18 x 25
024-036	20 x 30

⚠ WARNING

Hazardous Voltage!
Failure to disconnect power before servicing could result in death or serious injury.
Disconnect all electric power, including remote disconnects before servicing. Follow proper lockout/tagout procedures to ensure the power can not be inadvertently energized. Verify that no power is present with a voltmeter.

Check the contactors and relays within the control panel at least once a year. It is good practice to check the tightness of the various wiring connections within the control panel.

A strainer (60 mesh or greater) must be used on an open loop system to keep debris from entering the unit heat exchanger and to ensure a clean system.

For units on well water, it is important to check the cleanliness of the water-to-refrigerant heat exchanger. Should it become contaminated with dirt and scaling as a result of bad water, the heat exchanger will have to be back flushed and cleaned with a chemical that will remove the scale. This service should be performed by an experienced service person.

⚠ WARNING

Hazardous Chemicals!
Failure to follow this safety precaution could result in death or serious injury. Coil cleaning agents can be either acidic or highly alkaline and can burn severely if contact with skin or eyes occurs.
Handle chemical carefully and avoid contact with skin. ALWAYS wear Personal Protective Equipment (PPE) including goggles or face shield, chemical resistant gloves, boots, apron or suit as required. For personal safety refer to the cleaning agent manufacturer's Materials Safety Data Sheet and follow all recommended safe handling practices.

It should be noted that the water quality should be checked periodically.

Table 24. Water quality

Scaling	Amount
Calcium and magnesium (total hardness)	Less than 350 ppm
Corrosion	
pH	7-9.5
Hydrogen Sulfide	Less than 1 ppm
Sulfates	Less than 25 ppm
Chlorides	Less than 125 ppm
Carbon Dioxide	Less than 75 ppm
Total dissolved solids (TDS)	Less than 1000 ppm
Biological Growth	
Iron Bacteria	Low
Erosion	
Suspended Solids	Low

Troubleshooting

⚠ WARNING

Hazardous Service Procedures!

Failure to follow all precautions in this manual and on the tags, stickers, and labels could result in death or serious injury.

Technicians, in order to protect themselves from potential electrical, mechanical, and chemical hazards, **MUST** follow precautions in this manual and on the tags, stickers, and labels, as well as the following instructions: Unless specified otherwise, disconnect all electrical power including remote disconnect and discharge all energy storing devices such as capacitors before servicing. Follow proper lockout/tagout procedures to ensure the power can not be inadvertently energized. When necessary to work with live electrical components, have a qualified licensed electrician or other individual who has been trained in handling live electrical components perform these tasks.

Preliminary Trouble Inspection

- If operational difficulties are encountered, be sure to perform the preliminary checks before referring to [Table 25, p. 42](#).
- Verify that the unit is receiving electric supply power.
- Ensure that the fuses in the fused disconnect are intact.
- After completing the preliminary checks, inspect the unit for other obvious problems such as leaking connection, broken or disconnected wires, etc. If everything appears to be in order, but the unit still fails

Table 25. Troubleshooting checklist

Problem	Heating	Cooling	Cause	Correction
No response to any thermostat setting	X	X	Main power off	Check fuses
	X	X	Defective control transformer	Replace
	X	X	Broken or loose connection	Repair
	X	X	Defective thermostat	Replace
	X	X	Transformer	Reset Transformer
Unit short cycles	X	X	Thermostat or sensor improperly located	Relocate
Blower runs, but compressor does not	X	X	Defective compressor overload	Replace (if external)
	X	X	Defective compressor contactor	Replace
	X	X	Supply Voltage too low	Correct
	X	X	Defective compressor capacitor	Replace
	X	X	Defective windings	Replace
	X	X	Limit switches open	Check cause/Replace or repair

to operate properly, refer to the troubleshooting checklist on [Table 25, p. 42](#).

General Operation

The standard model is designed for indoor installation. When the unit is installed in an unconditioned space, the unit may not start in cool weather (approximately 45°F). It may then be necessary to start the unit in the cooling mode for three to five minutes. The unit may then be shut-off (there will be a two minute time-out of the unit), and restarted in the heating mode. The freeze protection thermostat should also be checked as it may be adversely affected by ambient temperature.

Like any other type of mechanical equipment, the unit performs best when it is well maintained.

Operation with a Conventional Thermostat

The unit is equipped with safety controls, including high pressure control, low pressure control and a freeze protection thermostat, set to shut off the compressor under abnormal temperature or pressure conditions. If the safeties shut off the compressor, a lockout relay prevents short cycling from the abnormal condition. When conditions are corrected, the lockout control can be reset by setting the thermostat system switch to OFF wait a few minutes for the system pressure to equalize, and then return to HEAT or COOL. If the condition continues, an authorized service person should check out the unit.

Table 25. Troubleshooting checklist (continued)

Problem	Heating	Cooling	Cause	Correction
Insufficient capacity	X	X	Dirty filter	Replace/clean
	X	X	Blower RPM too low	Correct
	X	X	Loss of conditioned air due to leaks in ductwork	Repair leaks
		X	Introduction of excessively hot return-air	Correct
	X		Introduction of excessively cold return-air	Correct
	X	X	Low on refrigerant charge	Locate leak, repair and recharge by weight (not by superheat)
	X	X	Restricted thermal expansion valve	Replace
	X	X	Defective reversing valve	See WSHP-IOM-# for touch test chart
	X	X	Thermostat improperly located	Relocate
	X	X	Unit undersized	Recalculate heat gains/losses
	X	X	Inadequate water flow	Increase GPM
	X	X	Scaling in heat exchanger	Clean or replace
		X	Water too hot	Decrease temperature
	X		Water too cold	Increase temperature
High pressure switch open		X	Inadequate GPM	Increase water flow to unit
		X	Water too hot	Decrease temperature
	X		Inadequate air flow	Check, clean blower and coil
	X		Dirty filter	Clean/replace
	X	X	Overcharged with refrigerant	Decrease charge
	X	X	Defective pressure switch	Check or replace
High head pressure		X	Trash in heat exchanger	Backflush
		X	Low water flow	Increase GPM
	X	X	Overcharge of refrigerant	Decrease charge
	X	X	Non-condensable in system	Evacuate and recharge by weight
	X	X	Water too hot	Decrease temperature
	X		Dirty filter	Clean / replace
	X		Inadequate air flow	Check, clean blower and coil
Low suction pressure	X	X	Undercharged	Locate leak, repair and recharge
	X	X	Restricted thermal expansion valve	Repair / replace
		X	Inadequate air flow	Check, clean blower and coil
		X	Dirty filter	Clean/replace
	X		Inadequate GPM	Increase GPM

Unit Wiring

Figure 20. Deluxe 24V with PSC motor

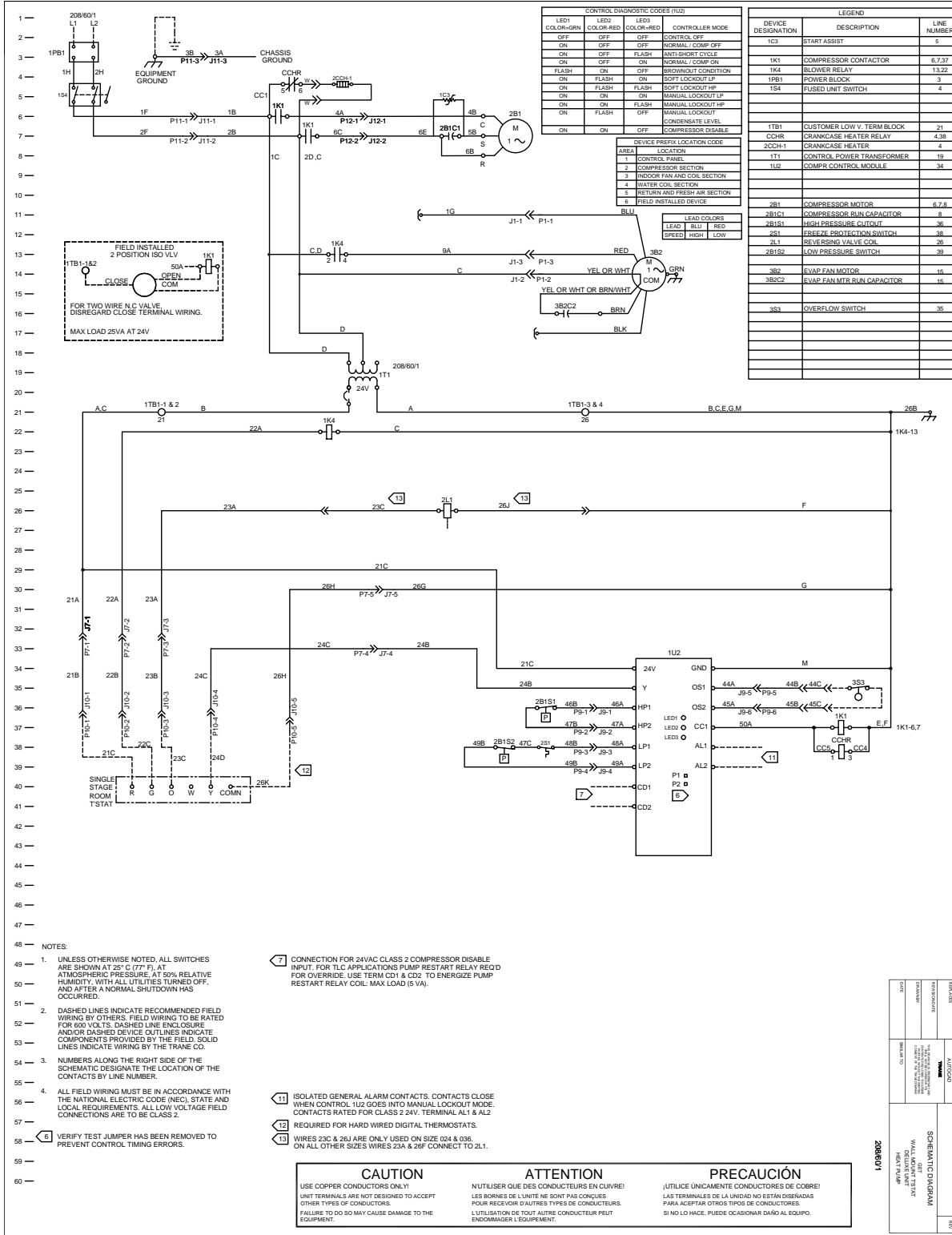

Figure 21. Deluxe 24V with ECM

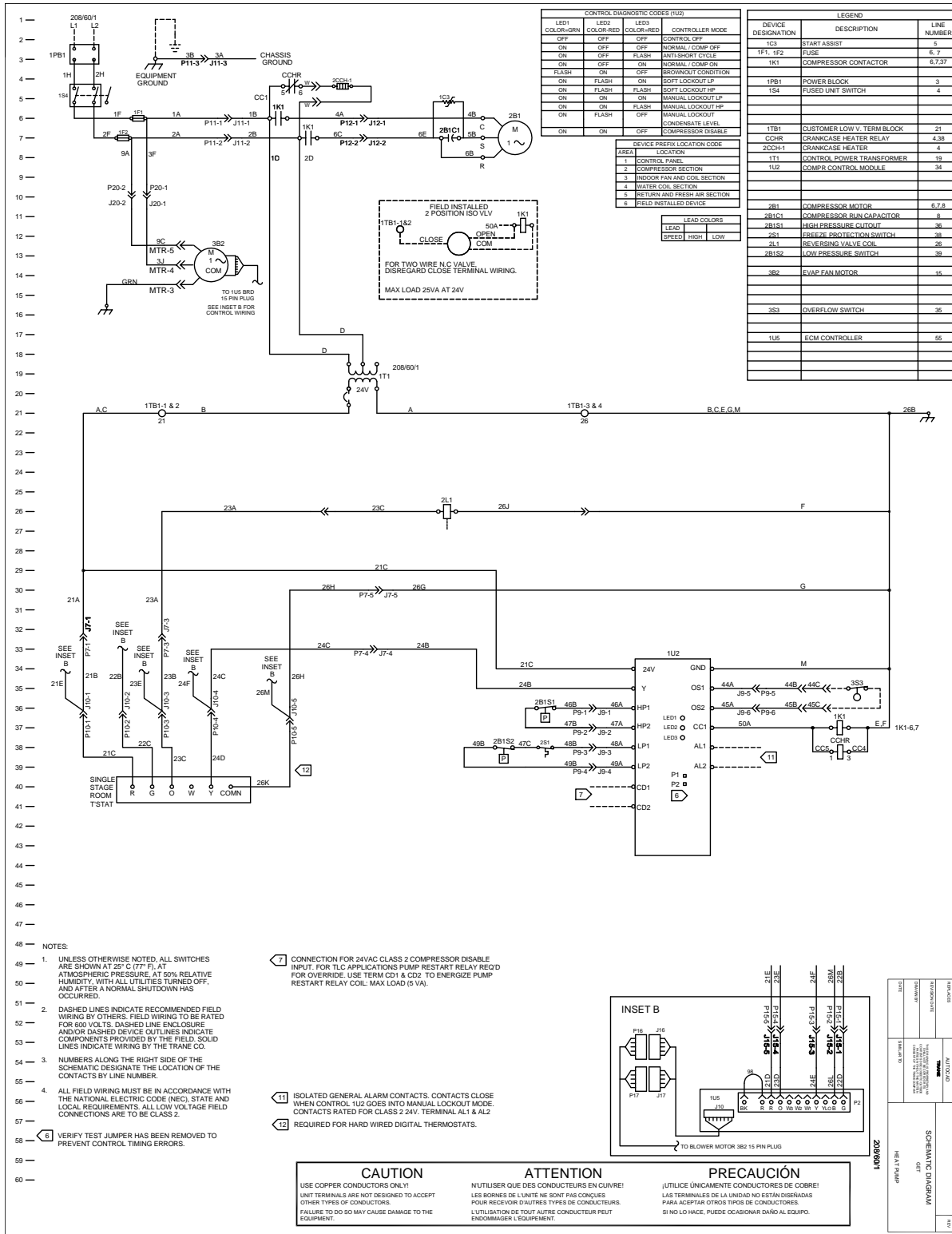

Figure 22. Symbio™ 400-B with ECM

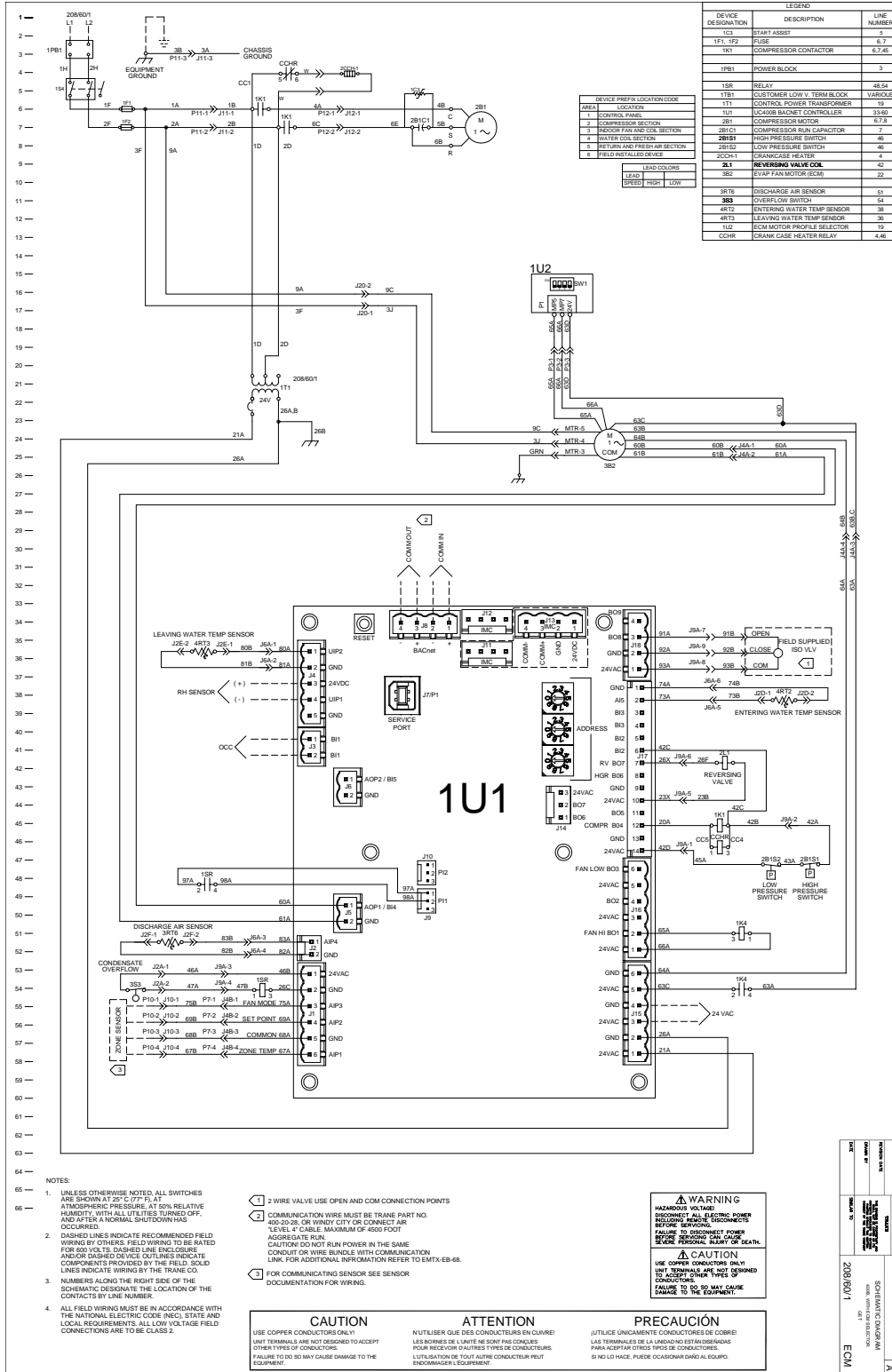
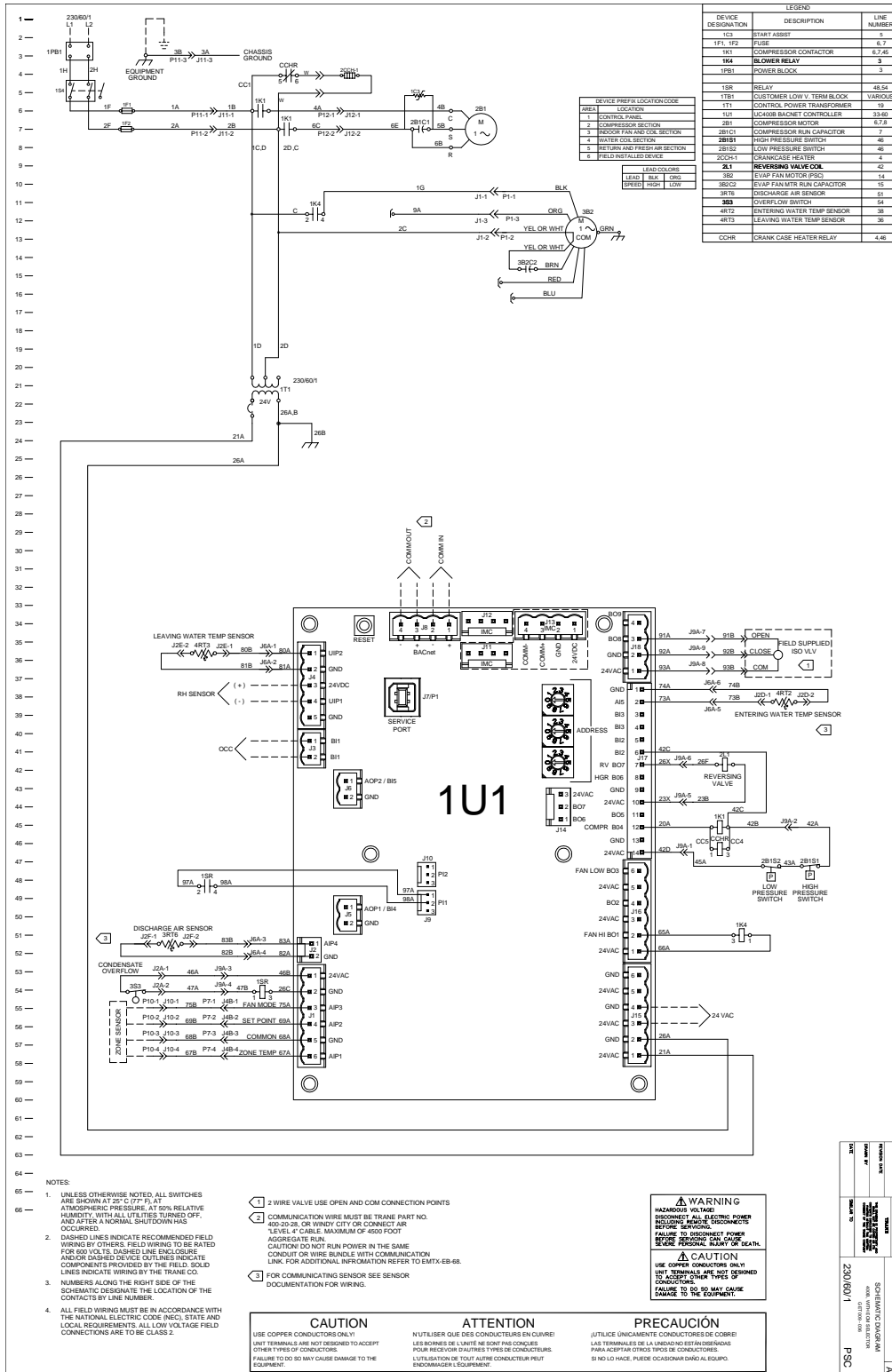

Figure 23. Symbio 400-B with PSC motor





Warranty

Standard Warranty

The standard water-source heat pump warranty is Trane parts-only warranty, running 12-months from start-up, not to exceed 18-months from shipment.

There is a standard five year compressor parts warranty.

Extended Warranty

The optional extended warranty is a second through fifth year warranty. The time starts at the end of standard 1-year coverage through the fifth year.

These extended warranties apply only to new equipment installed in domestic Trane Commercial sales territories and must be ordered prior to start-up.



Notes

Trane - by Trane Technologies (NYSE: TT), a global innovator - creates comfortable, energy efficient indoor environments for commercial and residential applications. For more information, please visit trane.com or tranetechnologies.com.

Trane has a policy of continuous product and product data improvements and reserves the right to change design and specifications without notice. We are committed to using environmentally conscious print practices.

WSHP-SVX020C-EN 28 Feb 2025
Supersedes WSHP-SVX020B-EN (October 2024)

©2025 Trane