



Installation, Operation, and Maintenance

# Water Source Heat Pump Axiom™ Horizontal/Vertical — EXH/EXV, DXH/DXV

0.75 to 6 Tons – 60 Hz, High Efficiency and Two-Stage High Efficiency



**Model Numbers:**

DXHK 024-070 - 60 Hz

DXVK 024-070 - 60 Hz

EXHK 009-070 - 60 Hz

EXVK 009-070 - 60 Hz

## ⚠ SAFETY WARNING

Only qualified personnel should install and service the equipment. The installation, starting up, and servicing of heating, ventilating, and air-conditioning equipment can be hazardous and requires specific knowledge and training. Improperly installed, adjusted or altered equipment by an unqualified person could result in death or serious injury. When working on the equipment, observe all precautions in the literature and on the tags, stickers, and labels that are attached to the equipment.



# Introduction

Read this manual thoroughly before operating or servicing this unit.

## Warnings, Cautions, and Notices

Safety advisories appear throughout this manual as required. Your personal safety and the proper operation of this machine depend upon the strict observance of these precautions.

The three types of advisories are defined as follows:



Indicates a potentially hazardous situation which, if not avoided, could result in death or serious injury.



Indicates a potentially hazardous situation which, if not avoided, could result in minor or moderate injury. It could also be used to alert against unsafe practices.



Indicates a situation that could result in equipment or property-damage only accidents.

## Important Environmental Concerns

Scientific research has shown that certain man-made chemicals can affect the earth's naturally occurring stratospheric ozone layer when released to the atmosphere. In particular, several of the identified chemicals that may affect the ozone layer are refrigerants that contain Chlorine, Fluorine and Carbon (CFCs) and those containing Hydrogen, Chlorine, Fluorine and Carbon (HCFCs). Not all refrigerants containing these compounds have the same potential impact to the environment. Trane advocates the responsible handling of all refrigerants.

## Important Responsible Refrigerant Practices

Trane believes that responsible refrigerant practices are important to the environment, our customers, and the air conditioning industry. All technicians who handle refrigerants must be certified according to local rules. For the USA, the Federal Clean Air Act (Section 608) sets forth the requirements for handling, reclaiming, recovering and recycling of certain refrigerants and the equipment that is used in these service procedures. In addition, some states or municipalities may have additional requirements that must also be adhered to for responsible management of refrigerants. Know the applicable laws and follow them.

### ⚠ WARNING

#### Proper Field Wiring and Grounding Required!

Failure to follow code could result in death or serious injury.

All field wiring **MUST** be performed by qualified personnel. Improperly installed and grounded field wiring poses **FIRE** and **ELECTROCUTION** hazards. To avoid these hazards, you **MUST** follow requirements for field wiring installation and grounding as described in **NEC** and your local/state/national electrical codes.

### ⚠ WARNING

#### Personal Protective Equipment (PPE) Required!

Failure to wear proper PPE for the job being undertaken could result in death or serious injury.

Technicians, in order to protect themselves from potential electrical, mechanical, and chemical hazards, **MUST** follow precautions in this manual and on the tags, stickers, and labels, as well as the instructions below:

- **Before installing/servicing this unit, technicians MUST put on all PPE required for the work being undertaken (Examples; cut resistant gloves/sleeves, butyl gloves, safety glasses, hard hat/bump cap, fall protection, electrical PPE and arc flash clothing). ALWAYS refer to appropriate Safety Data Sheets (SDS) and OSHA guidelines for proper PPE.**
- **When working with or around hazardous chemicals, ALWAYS refer to the appropriate SDS and OSHA/GHS (Global Harmonized System of Classification and Labelling of Chemicals) guidelines for information on allowable personal exposure levels, proper respiratory protection and handling instructions.**
- **If there is a risk of energized electrical contact, arc, or flash, technicians MUST put on all PPE in accordance with OSHA, NFPA 70E, or other country-specific requirements for arc flash protection, PRIOR to servicing the unit. NEVER PERFORM ANY SWITCHING, DISCONNECTING, OR VOLTAGE TESTING WITHOUT PROPER ELECTRICAL PPE AND ARC FLASH CLOTHING. ENSURE ELECTRICAL METERS AND EQUIPMENT ARE PROPERLY RATED FOR INTENDED VOLTAGE.**

**⚠ WARNING****Follow EHS Policies!**

Failure to follow instructions below could result in death or serious injury.

- All Trane personnel must follow the company's Environmental, Health and Safety (EHS) policies when performing work such as hot work, electrical, fall protection, lockout/tagout, refrigerant handling, etc. Where local regulations are more stringent than these policies, those regulations supersede these policies.
- Non-Trane personnel should always follow local regulations.

**⚠ WARNING****R-454B Flammable A2L Refrigerant!**

Failure to use proper equipment or components as described below could result in equipment failure, and possibly fire, which could result in death, serious injury, or equipment damage.

The equipment described in this manual uses R-454B refrigerant which is flammable (A2L). Use ONLY R-454B rated service equipment and components. For specific handling concerns with R-454B, contact your local representative.

**⚠ WARNING****Electrical Shock Hazard!**

Failure to follow instructions below could result in death or serious injury.

Properly connect the system's oversized protective earthing (grounding) terminal(s).

## Copyright

This document and the information in it are the property of Trane, and may not be used or reproduced in whole or in part without written permission. Trane reserves the right to revise this publication at any time, and to make changes to its content without obligation to notify any person of such revision or change.

## Trademarks

All trademarks referenced in this document are the trademarks of their respective owners.

## Product Safety Information

This appliance is not intended for use by persons (including children) with reduced physical, sensory or mental capabilities, or lack of experience and knowledge, unless they have been given supervision or instruction concerning use of the appliance by a person responsible for their safety. Children should be supervised to ensure that they do not play with the appliance.

Maximum altitude of use 3000 meters.

This appliance incorporates an earth connection for functional purposes only.

## Revision History

- Updated A2L chapter.
- Added a warning for storage in Job Storage section.
- Removed duplicate data.



# Table of Contents

|  |    |  |    |
|--|----|--|----|
| Model Number Description .....           | 6  | Leak Detection .....                       | 29 |
| EXVH/DXVH Models .....                   | 6  | Refrigerant Removal and                    |    |
| Overview of Manual .....                 | 7  | Evacuation .....                           | 29 |
| Unit Nameplate .....                     | 7  | Refrigerant Charging .....                 | 30 |
| Compressor Nameplate .....               | 7  | Decommissioning .....                      | 30 |
| Model Number Description .....           | 7  | A2L Application Considerations .....       | 30 |
| General Information .....                | 8  | Ignition Sources in Ductwork .....         | 31 |
| Unit Description .....                   | 8  | Ignition Sources in Unit .....             | 31 |
| Air-to-Refrigerant Coil .....            | 8  | Minimum Room Area Limits                   |    |
| Water-to-Refrigerant Coil .....          | 8  | (Refrigerant charge greater than 3.91 lb   |    |
| Controls .....                           | 8  | per circuit) .....                         | 31 |
| System Input Devices and Functions ..... | 8  | Leak Detection System (Refrigerant         |    |
| Deluxe 24V Controls (option) .....       | 8  | charge greater than 3.91 lb per            |    |
| Symbio™ 400-B (option) .....             | 8  | circuit) .....                             | 33 |
| Pump Module (Field Installed             |    | Installation .....                         | 34 |
| Accessory) .....                         | 8  | General Installation Checks .....          | 34 |
| Waterside Economizer (Option) .....      | 8  | Main Electrical .....                      | 34 |
| Boilerless Control/Electric Heat         |    | Electric Heat Requirements .....           | 34 |
| (Option) .....                           | 9  | Low Voltage Wiring (AC)                    |    |
| Operating Limits .....                   | 9  | Requirements .....                         | 34 |
| Pre-Installation .....                   | 11 | Filter Installation .....                  | 34 |
| Unit Inspection Checklist .....          | 11 | Supply-Air Ductwork .....                  | 35 |
| Jobsite Inspection Checklist .....       | 11 | Return-Air Ductwork .....                  | 35 |
| Jobsite Storage .....                    | 11 | Ducted Panel .....                         | 35 |
| Unit Dimensions .....                    | 13 | Ducted Filter Rack .....                   | 37 |
| Service Clearances .....                 | 13 | Sound Attenuation Pad .....                | 37 |
| Unit Dimensions .....                    | 15 | Hanging the Horizontal Unit .....          | 37 |
| Weights .....                            | 27 | Condensate Drain Connection .....          | 38 |
| Weight Distribution for Hanging the DXH  |    | Supply Pipe Connections .....              | 38 |
| and EXH Model .....                      | 27 | Cleaning and Flushing the Water Loop. .... | 38 |
| A2L Information and Installation         |    | Field Installed Power Wiring .....         | 39 |
| Requirements .....                       | 28 | Main Unit Power Wiring .....               | 39 |
| Installation/Code Compliance             |    | Control Power Transformer .....            | 39 |
| Requirements .....                       | 28 | Thermostat Location .....                  | 40 |
| A2L Work Procedures .....                | 28 | Thermostats and Zone Sensors .....         | 40 |
| Servicing .....                          | 28 | Controls Using 24 Vac .....                | 43 |
|  |    | External Smoke Detection Wiring to         |    |
|  |    | Unit .....                                 | 46 |
|  |    | Deluxe Controller .....                    | 46 |
|  |    | Symbio™ 400-B Controller .....             | 46 |



|   |    |                                    |    |
|---|----|------------------------------------|----|
| Airflow Adjustment . . . . .                | 46 | Water Pressure Drop . . . . .      | 61 |
| Units with Deluxe 24V controls . . . . .    | 46 | Water Volume . . . . .             | 62 |
| Waterside Economizer Installation . . . . . | 47 | Maintenance . . . . .              | 63 |
| Waterside Economizer Installation for       |    | Preventative Maintenance . . . . . | 63 |
| Horizontal 0.75 to 6 Ton Units . . . . .    | 47 | Condensate Trap . . . . .          | 64 |
| Waterside Economizer Installation for       |    | Troubleshooting . . . . .          | 65 |
| Vertical Units . . . . .                    | 48 | Deluxe Controls . . . . .          | 65 |
| Waterside Economizer Start-Up               |    | Wiring Diagram . . . . .           | 68 |
| Sequence . . . . .                          | 51 | Warranty Information . . . . .     | 69 |
| Pre-Start Checklist . . . . .               | 53 | Standard Warranty . . . . .        | 69 |
| Start-Up . . . . .                          | 54 | Extended Warranty . . . . .        | 69 |
| Initial Unit Start-Up . . . . .             | 54 |                                    |    |
| Start-Up Checklist and Log . . . . .        | 54 |                                    |    |
| Operating Pressures . . . . .               | 54 |                                    |    |



# Model Number Description

## EXVH/DXVH Models

### Digits 1–3 — Unit Configuration

**EXV** = High Efficiency Vertical  
**DXV** = Two-stage High Efficiency Vertical  
**EXH** = High Efficiency Horizontal  
**DXH** = Two-stage High Efficiency Horizontal

### Digit 4 — Development Sequence

**K** = R-454B

### Digits 5–7 — Nominal Size (MBH)

**009** = 9.0 MBH (EX only)  
**012** = 12.0 MBH (EX only)  
**015** = 15.0 MBH (EX only)  
**018** = 18.0 MBH (EX only)  
**024** = 24.0 MBH  
**030** = 30.0 MBH (EX only)  
**036** = 36.0 MBH  
**042** = 42.0 MBH (EX only)  
**048** = 48.0 MBH  
**060** = 60.0 MBH  
**070** = 70.0 MBH

### Digit 8 — Voltage (Volts/Hz/Phase)

**4** = 460/60/3  
**7** = 265/60/1  
**A** = 208-230/60/1  
**B** = 208-230/60/3

### Digit 9 — Heat Exchanger

**1** = Copper-Water Coil  
**2** = Cupro-Nickel Water Coil  
**7** = Insulated Copper-Water Coil/Suction Line  
**8** = Insulated Cupro-Nickel Water Coil/Suction Line

### Digit 10 — Design Sequence

**A** = First Design Sequence

### Digit 11 — Refrigeration Circuit

**0** = Heating and Cooling Circuit  
**2** = Heating and Cooling Circuit with Hot Gas Reheat  
**3** = Heating and Cooling Circuit with Waterside Economizer  
**4** = Heating and Cooling Circuit with Waterside Economizer, Hot Gas Reheat

### Digit 12 — Blower Configuration

**K** = Variable ECM Motor, Constant Torque

### Digit 13 — Freeze Protection<sup>2</sup>

**A** = 20°F Freezestat (For Glycol Loop)  
**B** = 35°F Freezestat (For Water Loop)

### Digit 14 — Open Digit = 0

### Digit 15 — Supply-Air Arrangement

**T** = Top Supply-Air Arrangement  
**B** = Back Supply-Air Arrangement  
**L** = Left Supply-Air Arrangement  
**R** = Right Supply-Air Arrangement

### Digit 16 — Return-Air Arrangement

**L** = Left Return-Air Arrangement  
**R** = Right Return-Air Arrangement

### Digit 17 — Control Types

**D** = Deluxe 24V Controls  
**H** = Symbio™ 400-B  
**J** = Symbio 400-B w/Air-Fi® Wireless Communications

### Digit 18 — Tstat/Sensor Location

**0** = Wall Mounted Location

### Digit 19 — Fault Sensors

**1** = Condensate Overflow Sensor  
**3** = Condensate Overflow and Filter Maintenance Timer  
**6** = Condensate Overflow and Fan Status  
**J** = Fan Status, Filter Maintenance Timer and Condensate Overflow Sensor

### Digit 20 — Temperature Sensor

**0** = No Additional Temperature Sensor  
**1** = Entering Water Sensor

### Digit 21 — Insulation

**1** = Matte Faced Insulation  
**2** = Foil Faced Insulation

### Digit 22 — Electric Heat

**0** = No Electric Heat  
**6** = Field Mounted External Boilerless LOW Electric Heat  
**7** = Field Mounted External Boilerless MED Electric Heat  
**8** = Field Mounted External Boilerless HIGH Electric Heat  
**9** = Boilerless Electric Heat Ready

### Digit 23 — Unit Mounted Disconnect

**0** = No Unit Mounted Disconnect  
**2** = Unit Mounted Disconnect

### Digit 24 — Filter Type

**1** = 1-inch Throwaway Filter  
**2** = 2-inch Throwaway Filter  
**4** = 2-inch MERV 8  
**5** = 2-inch MERV 13

### Digit 25 — Acoustic Arrangement

**1** = Standard Sound Attenuation  
**2** = Deluxe Sound Attenuation

### Digits 26–36 — Does Not Apply

**0000000000** = Digits 26-36 are not applicable to the EXV or DXV products

### Digit 37 — Ducted Filter Rack

**0** = Non-ducted filter rack  
**A** = Ducted Filter Rack Side Access/LH-RH  
**C** = Ducted Filter Rack (Bottom Access)

### Digit 38 — Isolation Valve

**0** = No Isolation Valve  
**1** = Factory Mounted Isolation Valve

### Digit 39 — Power Connection

**1** = Single Point  
**2** = Electric Heat Power Separate from Unit

### Digit 40 — Drain Pan

**A** = Polymer Drain Pan  
**B** = Stainless Steel Drain Pan

### Model Number Note:

#### Notes:

1. Deluxe Sound option to be made available in later product release.
2. 20°F Freezestat is typically used in a geothermal application. 35°F Freezestat is typically used in a boiler/tower application



## Overview of Manual

**Note:** *One copy of this document ships inside the control panel of each unit and is customer property. It must be retained by the unit's maintenance personnel.*

This booklet describes proper installation, operation, and maintenance procedures for air cooled systems.

By carefully reviewing the information within this manual and following the instructions, the risk of improper operation and/or component damage will be minimized.

It is important that periodic maintenance be performed to help assure trouble free operation. A maintenance schedule is provided at the end of this manual.

Should equipment failure occur, contact a qualified service organization with qualified, experienced technicians to properly diagnose and repair this equipment.

### Unit Nameplate

The unit nameplate is located on the outside of the control box access panel at the front of the unit. It includes the unit

model number, serial number, electrical characteristics, refrigerant charge, and other pertinent unit data.

### Compressor Nameplate

The nameplate for the compressors are located on the compressor shell.

### Model Number Description

All products are identified by a multiple-character model number that precisely identifies a particular type of unit. Its use will enable the owner/operator, installing contractors, and service engineers to define the operation, specific components, and other options for any specific unit.

When ordering replacement parts or requesting service, be sure to refer to the specific model number and serial number printed on the unit nameplate.



# General Information

## Unit Description

Before shipment, each unit is leak tested, dehydrated, charged with refrigerant, and run tested for proper control operation.

## Air-to-Refrigerant Coil

The air-to-refrigerant coil is aluminum fin, mechanically bonded to the copper tubing.

## Water-to-Refrigerant Coil

The water-to-refrigerant coil is a copper or cupro-nickel (option) and steel tube (tube-within-a-tube) design, leak tested to confirm there is no cross leakage between the water tube (copper/cupro-nickel) and refrigerant gas (steel tube).

Table 1. High/low pressure switch

|    | Trip      | Recover   | Unit |
|----|-----------|-----------|------|
| LP | 40 +/-4   | 56 +/-4   | psig |
| HP | 600 +/-10 | 550 +/-10 | psig |

Additives like glycol can be added to reduce the freezing point of the water. Units are not intended to be connected to sanitary water.

- Entering water temperatures range from 25°F to 120°F.
- Leaving water temperature deltas range from 10°F to 15°F.
- Maximum water pressure allowed in system is 400 psi.

## Controls

The available control type is a Deluxe 24V control option, a Symbio™ 400-B control option for all unit sizes.

All power wiring to the equipment is made at the unit's compressor contactor or optional disconnect switch for the EXH/V 0.75 to 6 ton units and the DXH/V 2 to 6 ton units. For units without the disconnect switch, the power wiring needs to be connected to the screw terminals of the compressor contactor. All low-voltage wiring is made at the unit's low voltage terminal plug.

## System Input Devices and Functions

A thermostat, zone sensor, or building automation system is required to operate the water-source heat pump. The flexibility of having several mode capabilities depends upon the type of sensor and/or remote panel selected.

Troubleshooting and connection diagrams for the 24V control systems may be located in the back of this manual. All digital control troubleshooting tips and connection

diagrams are located in Symbio™ 400-B/500 Programmable Controllers Water Source Heat Pump (WSHP) Installation, Operation, and Maintenance guide (BAS-SVX092\*-EN).

## Deluxe 24V Controls (option)

Units containing the Deluxe 24V control design will incorporate a microprocessor-based control board. The Trane microprocessor board is factory wired to a terminal plug to provide all necessary terminals for field connection. The deluxe board is equipped with a random start relay, anti-short cycle timer, brown out protection, compressor disable, condensate overflow, unit safety control, diagnostics, and a generic relay (which may be available for field use).

## Symbio™ 400-B (option)

The Symbio 400-B is a BTL Listed BACnet® controller that can operate stand-alone or within a Building Automation System (BAS) such as Tracer® SC+. For installation, operation, and maintenance, see Symbio™ 400-B/500 Programmable Controllers Water Source Heat Pump (WSHP) Installation, Operation, and Maintenance guide (BAS-SVX092\*-EN).

## Pump Module (Field Installed Accessory)

The pump module consists of either a single or dual 1/6 HP cast iron pump and a brass three-way shut-off valve. The pump module kits contains the necessary components for the installation, operation, and maintenance of the water circuit of a closed-loop distributed pumping application.

## Waterside Economizer (Option)

Instructions for mechanical connection of the waterside economizer to the water-source heat pump may be found in the dimensional section of this manual.

The waterside economizer is designed to begin economizing mode when water temperatures fall below the field adjustable temperature of 25, 35, 45, 55 or 60°F (for the Deluxe control option), or below the programmed set-point (for the Symbio™ 400-B control option).

When the temperature is less than the setpoint, fluid will flow into the economizing coil, while simultaneously halting mechanical operation of the compressor. Mechanical cooling will continue on a call for a second stage from the thermostat or system control. Entering water temperature sensor is factory provided for field installation on the entering water side of the coil.

## Boilerless Control/Electric Heat (Option)

This option targets building designs that do not incorporate a boiler to heat the loop system. During a heavy heating load, the loop temperature may begin to fall. As the loop temperature decreases, the heating capacity of the heat pump also decreases. In the heating mode, when the loop temperature falls below 55°F (factory setting), the electric heater is energized, and the compressor is locked out. The system's electric heat source is utilized for primary heating until the loop temperature rises above 60°F. Once the loop temperature rises above 60°F, the boilerless controller

returns the unit to normal compressor heating operation and locks out the electric heater.

The electric heat must be field installed by the contractor.

**Note:** The boilerless controller has a field adjustable entering water temperature setting of 25, 35, 45, 55, and 60 degrees. The compressor operation will return to normal operation when the loop temperature rises 5 degrees above the setpoint. This electric heat option is designed for primary heat only, not to run as supplemental heat to the heating function of the heat pump.

**Table 2. Refrigerant charge (EXH/EXV)**

| Model (60 Hz) | Heat Pump (oz)/Kg) |           | Heat Pump w/ HGR (oz)/Kg) |           |
|---------------|--------------------|-----------|---------------------------|-----------|
|               | Circuit 1          | Circuit 2 | Circuit 1                 | Circuit 2 |
| EXH/V009      | 33.5/0.94          | —         | 35.0 / 0.99               | —         |
| EXH/V012      | 32.5/0.92          | —         | 34.0 / 0.96               | —         |
| EXH/V015      | 33.5/0.94          | —         | 35.5/1.00                 | —         |
| EXH/V018      | 45.5/1.28          | —         | 47.5/1.34                 | —         |
| EXH/V024      | 48.0/1.36          | —         | 50.0/1.41                 | —         |
| EXH/V030      | 57.5/1.63          | —         | 60.5/1.71                 | —         |
| EXH/V036      | 59.5/1.68          | —         | 62.0/1.75                 | —         |
| EXH/V042      | 72.0/2.04          | —         | 76.0/2.15                 | —         |
| EXH/V048      | 74.0/2.09          | —         | 78.0/2.21                 | —         |
| EXH/V060      | 84.0/2.38          | —         | 89.0/2.52                 | —         |
| EXH/V070      | 100.0/2.83         | —         | 105.0/2.97                | —         |

**Table 3. Refrigerant charge (DXH/DXV)**

| Model (60 Hz) | Heat Pump (oz)/Kg) |           | Heat Pump w/ HGR (oz)/Kg) |           |
|---------------|--------------------|-----------|---------------------------|-----------|
|               | Circuit 1          | Circuit 2 | Circuit 1                 | Circuit 2 |
| DXH/V024      | 50.0/1.41          | —         | 52.0/1.47                 | —         |
| DXH/V036      | 56.5/1.60          | —         | 59.5/1.68                 | —         |
| DXH/V048      | 73.0/2.06          | —         | 77.0/2.18                 | —         |
| DXH/V060      | 86.5/2.45          | —         | 92.0/2.60                 | —         |
| DXH/V070      | 100.0/2.83         | —         | 105.0/2.97                | —         |

## Operating Limits

**Table 4. Operating limits - 0.75 to 6 tons**

| Operating Limits    | Cooling                   | Heating             |
|---------------------|---------------------------|---------------------|
| <b>Air Limits</b>   |                           |                     |
| Min. ambient air DB | 45°F (7°C)                |                     |
| Max. ambient air DB | 130°F (54.4°C)            |                     |
| Min. EAT DB/WB      | 70.0/50.0°F (21.1/10.0°C) | 55.0°F/- (12.8°C/-) |



## General Information

**Table 4. Operating limits - 0.75 to 6 tons (continued)**

| Operating Limits                | Cooling                             | Heating             |
|---------------------------------|-------------------------------------|---------------------|
| Max. EAT DB/WB                  | 85.0/78.0°F (29.4/25.6°C)           | 80.0°F/- (26.6°C/-) |
| Airflow range                   | 305 to 455 CFM/ton <sup>(a)</sup>   |                     |
| <b>Water Limits</b>             |                                     |                     |
| Min. entering water temperature | 45°F (7°C)                          | 25°F (-4°C)         |
| Max. entering water temperature | 120°F (49°C)                        | 86°F (30°C)         |
| Max. water pressure             | 400 PSIG (2758 kPa)                 |                     |
| Water flow range                | 1.95 to 3.60 GPM/ton <sup>(a)</sup> |                     |

<sup>(a)</sup> This value is an average and varies per model. See performance tables for each model number's rated values.



# Pre-Installation

## ⚠ WARNING

### Fiberglass Wool!

Exposure to glass wool fibers without all necessary PPE equipment could result in cancer, respiratory, skin or eye irritation, which could result in death or serious injury. Disturbing the insulation in this product during installation, maintenance or repair will expose you to airborne particles of glass wool fibers and ceramic fibers known to the state of California to cause cancer through inhalation.

You **MUST** wear all necessary Personal Protective Equipment (PPE) including gloves, eye protection, a NIOSH approved dust/mist respirator, long sleeves and pants when working with products containing fiberglass wool.

#### Precautionary Measures:

- Avoid breathing fiberglass dust.
- Use a NIOSH approved dust/mist respirator.
- Avoid contact with the skin or eyes. Wear long-sleeved, loose-fitting clothing, gloves, and eye protection.
- Wash clothes separately from other clothing; rinse washer thoroughly.
- Operations such as sawing, blowing, tear-out, and spraying may generate fiber concentrations requiring additional respiratory protection. Use the appropriate NIOSH approved respirator.

#### First Aid Measures:

- Eye Contact - Flush eyes with water to remove dust. If symptoms persist, seek medical attention.
- Skin Contact - Wash affected areas gently with soap and warm water after handling.

## Unit Inspection Checklist

**Note:** The packaging for these units are tested per, and compliant with, the requirements of NMFC Item 180 Certified Packaged Products.

- Unpack all components of the kit.
- Check carefully for any shipping damage. If any damage is found it must be reported immediately and a claim made against the transportation company.

**Important:** Equipment is shipped FOB (Free on Board) at the manufacturer. Therefore, freight claims for damages against the carrier must be initiated by the receiver.

- Visually inspect the components for shipping damage as soon as possible after delivery, before it is stored. Concealed damage must be reported within 15 days.
- If concealed damage is discovered, stop unpacking the shipment.
- Do not remove damaged material from the receiving location. Take photos of the damage, if possible. The owner must provide reasonable evidence that the damage did not occur after delivery.
- Notify the carrier's terminal of damage immediately by phone and by mail. Request an immediate joint inspection of the damage by the carrier and the consignee.
- Do not attempt to repair any damaged parts until the parts are inspected by the carrier's representative.

## Jobsite Inspection Checklist

Always perform the following checks before accepting a unit:

- Verify that the nameplate data matches the data on the sales order and bill of lading (including electrical data).
- Verify that the power supply complies with the unit nameplate specifications.
- Visually inspect the exterior of the unit, for signs of shipping damage. Do not sign the bill of lading accepting the unit(s) until inspection has been completed. Check for damage promptly after the unit(s) are unloaded. Once the bill of lading is signed at the jobsite, the unit(s) are now the property of the SOLD TO party and future freight claims MAY NOT be accepted by the freight company.

## Jobsite Storage

### ⚠ WARNING

#### Risk of Fire — Flammable Refrigerant!

Failure to follow instructions below could result in death or serious injury, and equipment damage. The equipment shall be stored in a room without continuously operating ignition sources.





### NOTICE

#### Microbial Growth!

Failure to follow instructions below could result in odors and damage to the equipment and building materials.

**The floor or foundation must be level and the condensate drain at the proper height for proper drainage and condensate flow. Standing water and wet surfaces inside the equipment can become an amplification site for microbial growth (mold). If there is evidence of microbial growth on the interior insulation, it should be removed and replaced prior to operating the system.**

This unit is intended for indoor use only. To protect the unit from damage due to the elements, and to prevent possible IAQ contaminant sources from growing, the unit should be stored indoors. If indoor storage is not possible, the following provisions for outdoor storage must be met:

- Place the unit(s) on a dry surface or raise above the ground to assure adequate air circulation beneath the unit.
- Cover the unit(s) with a water proof tarp to protect them from the elements.
- Make provisions for continuous venting of the covered units to prevent moisture from standing on the unit(s) surfaces. Wet interior unit insulation can become an amplification site for microbial growth (mold) which has been determined to be a cause of odors and serious health related indoor air quality problems.
- Store units in the normal UP orientation to maintain oil in the compressor.
- Stack horizontal units no more than three units high. Do not stack the vertical unit configurations.



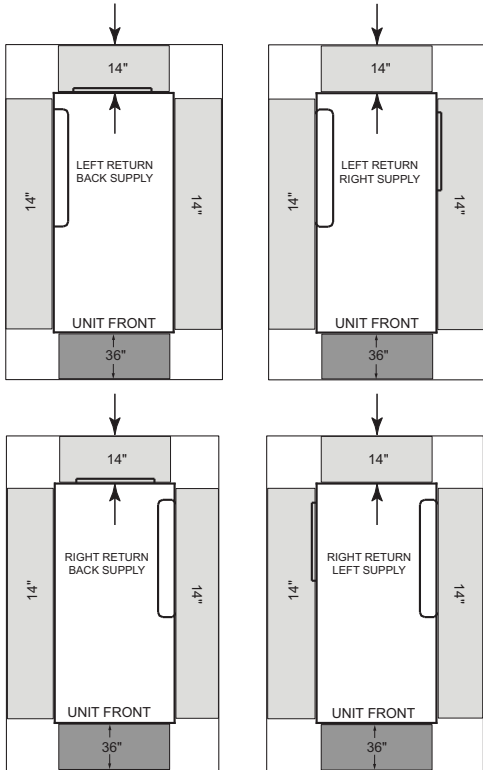
# Unit Dimensions

## Service Clearances

Per NEC requirements, 36 inches of access and working space is provided and maintained around all control boxes and electrical equipment to permit ready and safe

operation and maintenance of such equipment. Local codes may require more clearance to electrical equipment. Check all code requirements prior to unit installation.

Figure 1. Clearances - EXH/DXH 0.75 to 6 tons



A minimum 14-inch clearance for servicing the unit is required for all EXH 0.75 to 6 tons configurations from other mechanical and electrical equipment (where shown) to enable panel removal from the unit for service/maintenance ability. The optimum clearance required is 20 inches.

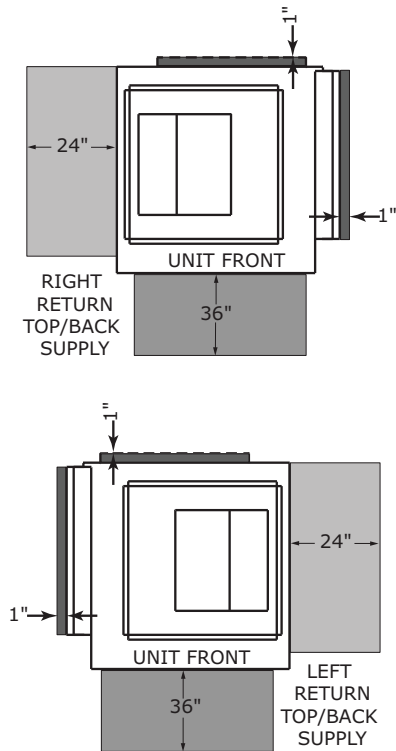
**Notes:**

- Return air direction (left-hand or right hand) is NOT field convertible. Units must be ordered with correct return air side.
- For horizontal models, confirm enough clearance between the condensate drain and the ceiling for pitching of the condensate line. See Figure 20, p. 38 for pitching requirements.



## Unit Dimensions

Figure 2. Clearance – EXVK/DXVK 0.75 to 6 tons



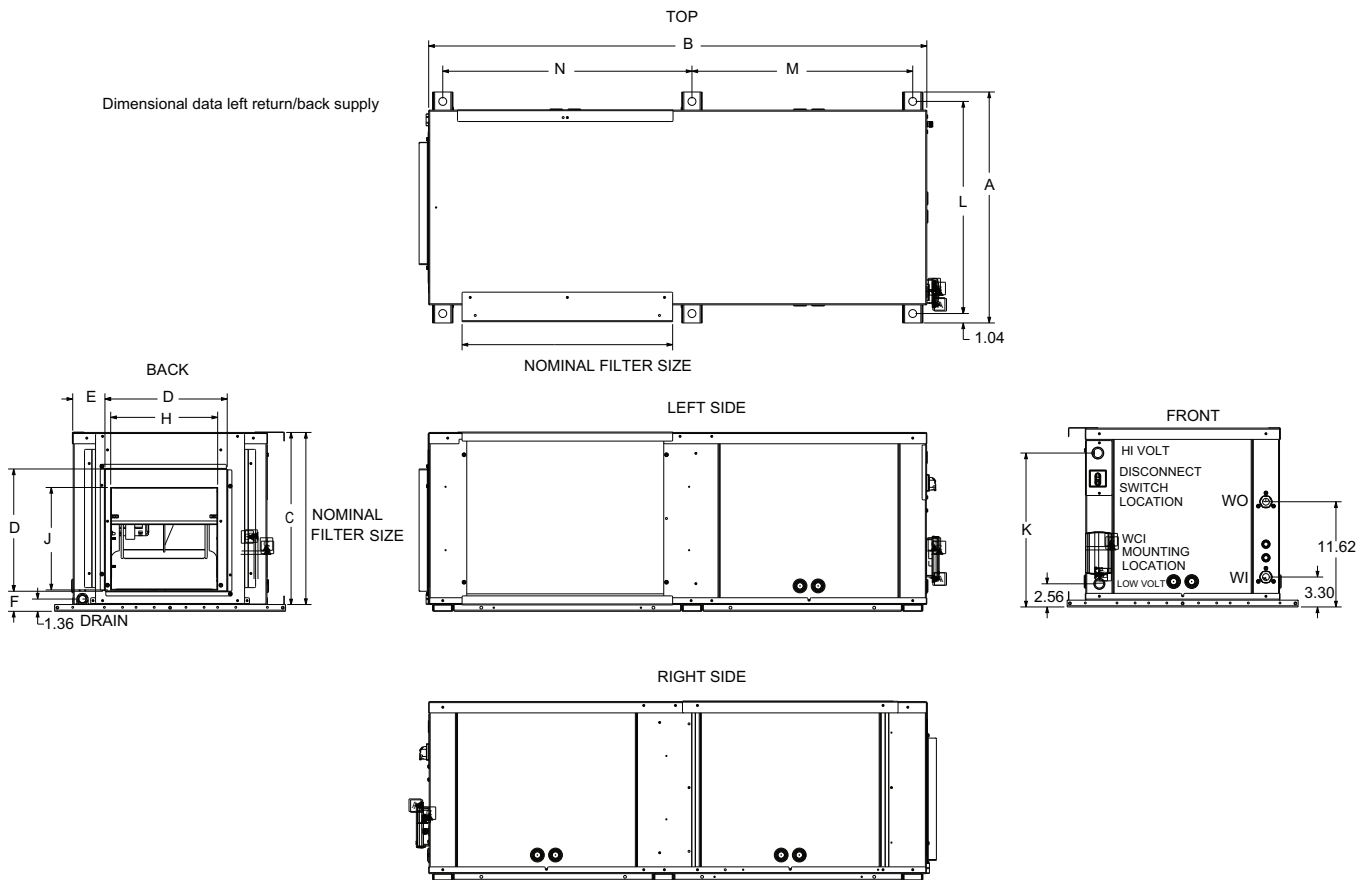
A 24-inch clearance from other mechanical and electrical equipment (where shown) is recommended for most unit configurations. This will enable panel removal from the unit for service/maintenance.

The 24-inch side clearance on EXVK/DXVK 0.75 to 6T models is for optimal access only. Side clearance is not a requirement as most components can be accessed from the front of the unit.

A 1-inch minimum clearance between the filter rack and any obstacle is required for units in a free return application to provide proper air flow to the air-to-refrigerant coil. A 12-inch minimum clearance between the filter rack and any obstacle should be provided to properly attached ductwork.

The 1-inch dimension shown in the back of the unit represents the supply duct collar for the back supply option. This clearance is needed to clear these flanges.

# Unit Dimensions

**Figure 3. Left return/back supply (EXHK/DXHK)**

**Table 5. Dimensional data left return/back supply (EXHK/DXHK)**

| Cab | Unit     |         | Width | Depth | Height | Duct Collar | Duct Collar Location |      |       | Blower Opening |       | Hi Volt | Unit hanging location |       |                  | Nominal Filter Size | W.I. NPTI | W.O. NPTI | DRAIN NPTI |
|-----|----------|---------|-------|-------|--------|-------------|----------------------|------|-------|----------------|-------|---------|-----------------------|-------|------------------|---------------------|-----------|-----------|------------|
|     | EXHK     | DXHK    | A     | B     | C      | D           | E                    | F    | H     | J              | K     | L       | M                     | N     |                  |                     |           |           |            |
| B   | 009, 012 | —       | 25.50 | 46.00 | 17.75  | 13.50       | 3.50                 | 2.00 | 10.13 | 9.38           | 15.00 | 23.50   | 19.88                 | 23.00 | 16 x 19          | 0.50                | 0.50      | 0.75      |            |
| C   | 015      | —       | 25.50 | 49.00 | 18.75  | 13.50       | 3.88                 | 2.25 | 10.50 | 11.25          | 16.00 | 23.50   | 21.38                 | 24.50 | 17 x 20          | 0.75                | 0.75      | 0.75      |            |
| D   | 018, 024 | 024     | 25.50 | 55.00 | 19.75  | 13.50       | 3.50                 | 2.25 | 11.75 | 11.25          | 17.00 | 23.50   | 24.38                 | 27.50 | 18 x 23          | 0.75                | 0.75      | 0.75      |            |
| E   | 030,036  | 036     | 28.00 | 68.00 | 21.75  | 16.50       | 3.63                 | 2.13 | 13.88 | 13.50          | 19.00 | 26.00   | 30.88                 | 34.00 | 20 x 30          | 1.00                | 1.00      | 0.75      |            |
| F   | 042, 048 | 048     | 29.38 | 77.75 | 22.13  | 16.50       | 3.50                 | 2.50 | 13.88 | 13.50          | 19.25 | 27.25   | 30.88                 | 43.75 | 20 x 20 (x2)     | 1.00                | 1.00      | 0.75      |            |
| G   | 060, 070 | 060,070 | 29.38 | 86.75 | 22.13  | 16.50       | 3.50                 | 2.50 | 13.88 | 13.50          | 19.25 | 27.25   | 30.88                 | 52.75 | 20 x 20, 20 x 30 | 1.00                | 1.00      | 0.75      |            |

**Note:** Dimensions represent unit hanging dimensions including base rails for hanging.

# Unit Dimensions

Figure 4. Left return/right supply (EXHK/DXHK)

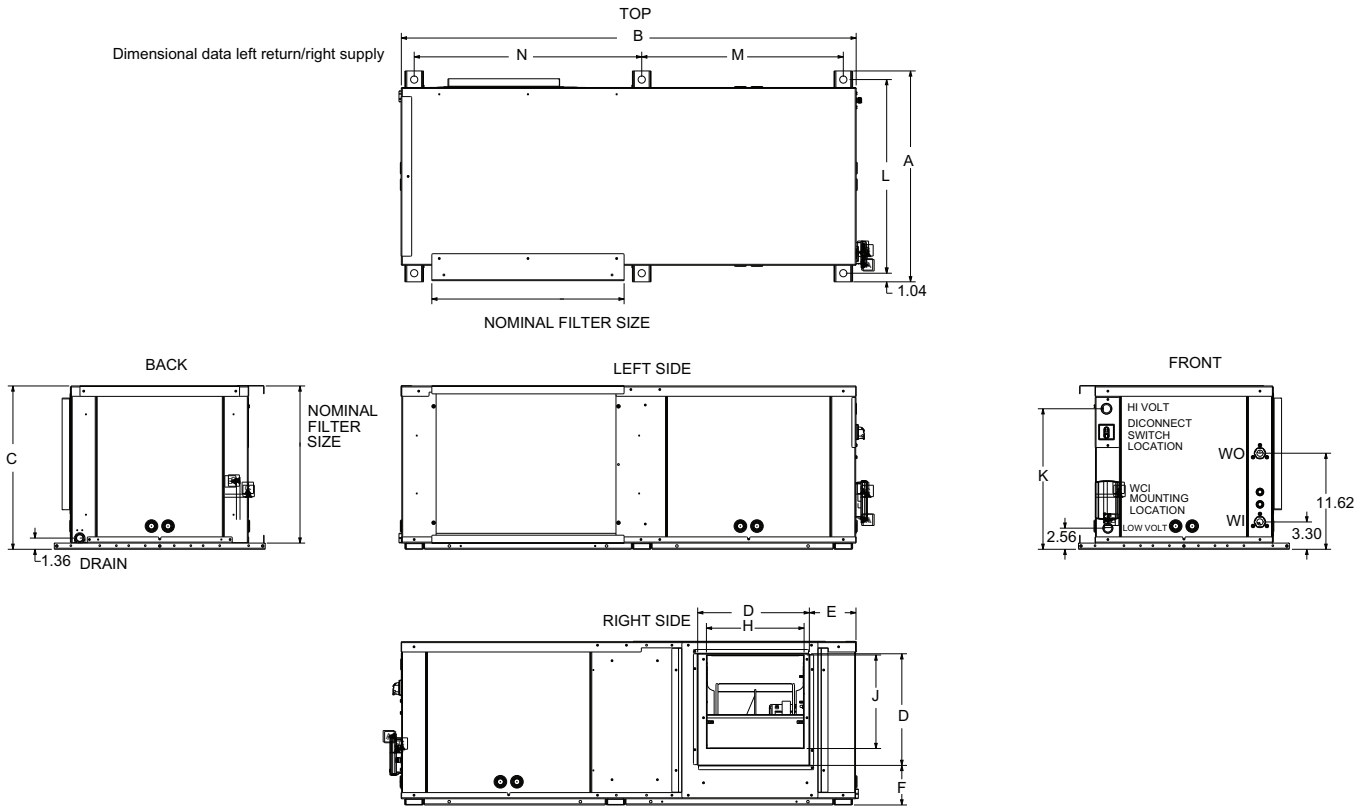
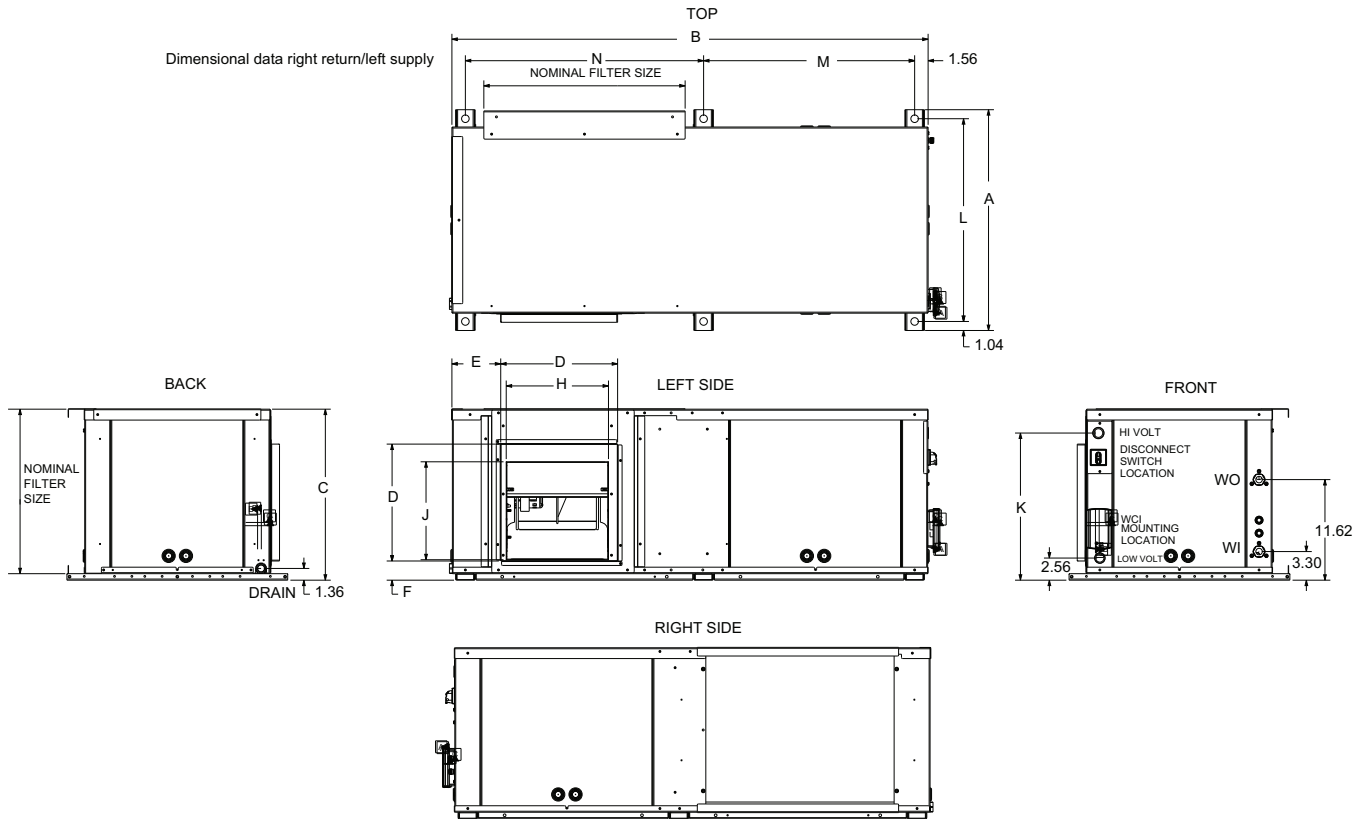


Table 6. Dimensional data left return/right supply (EXHK/DXHK)

| Cab | Unit     |         | Width<br>A | Depth<br>B | Height<br>C | Duct<br>Collar<br>D | Duct Collar<br>Location |      |       | Blower<br>Opening |       | Hi<br>Volt<br>K | Unit hanging<br>location |       |                     | Nominal<br>Filter<br>Size | W.I.<br>NPTI | W.O.<br>NPTI | DRAIN<br>NPTI |
|-----|----------|---------|------------|------------|-------------|---------------------|-------------------------|------|-------|-------------------|-------|-----------------|--------------------------|-------|---------------------|---------------------------|--------------|--------------|---------------|
|     | EXHK     | DXHK    |            |            |             |                     | E                       | F    | H     | J                 | L     |                 | M                        | N     |                     |                           |              |              |               |
| B   | 009, 012 | -       | 25.50      | 46.00      | 17.75       | 13.50               | 3.38                    | 3.00 | 10.13 | 9.38              | 15.00 | 23.50           | 19.88                    | 23.00 | 16 x 19             | 0.50                      | 0.50         | 0.75         |               |
| C   | 015      | -       | 25.50      | 49.00      | 18.75       | 13.50               | 5.88                    | 4.00 | 10.50 | 11.25             | 16.00 | 23.50           | 21.38                    | 24.50 | 17 x 20             | 0.75                      | 0.75         | 0.75         |               |
| D   | 018, 024 | 024     | 25.50      | 55.00      | 19.75       | 13.50               | 5.63                    | 4.75 | 11.75 | 11.25             | 17.00 | 23.50           | 24.38                    | 27.50 | 18 x 23             | 0.75                      | 0.75         | 0.75         |               |
| E   | 030,036  | 036     | 28.00      | 68.00      | 21.75       | 16.50               | 5.63                    | 3.88 | 13.88 | 13.50             | 19.00 | 26.00           | 30.88                    | 34.00 | 20 x 30             | 1.00                      | 1.00         | 0.75         |               |
| F   | 042, 048 | 048     | 29.38      | 77.75      | 22.13       | 16.50               | 5.63                    | 3.75 | 13.88 | 13.50             | 19.25 | 27.25           | 30.88                    | 43.75 | 20 x 20<br>(x2)     | 1.00                      | 1.00         | 0.75         |               |
| G   | 060, 070 | 060,070 | 29.38      | 86.75      | 22.13       | 16.50               | 5.63                    | 3.75 | 13.88 | 13.50             | 19.25 | 27.25           | 30.88                    | 52.75 | 20 x 20, 20<br>x 30 | 1.00                      | 1.00         | 0.75         |               |

Note: Dimensions represent unit hanging dimensions including base rails for hanging.

**Figure 5. Right return/left supply (EXHK/DXHK)**

**Table 7. Dimensional data right return/left supply (EXHK/DXHK)**

| Cab | Unit     |          | Width<br>A | Depth<br>B | Height<br>C | Duct Collar Location |      |      | Blower Opening |       | Hi Volt<br>K | Unit hanging location |       |       | Nominal Filter Size | W.I. NPTI | W.O. NPTI | DRAIN NPTI |
|-----|----------|----------|------------|------------|-------------|----------------------|------|------|----------------|-------|--------------|-----------------------|-------|-------|---------------------|-----------|-----------|------------|
|     | EXHK     | DXHK     |            |            |             | D                    | E    | F    | H              | J     |              | L                     | M     | N     |                     |           |           |            |
| B   | 009, 012 | –        | 25.50      | 46.00      | 17.75       | 13.50                | 5.50 | 2.00 | 10.13          | 9.38  | 15.00        | 23.50                 | 19.88 | 23.00 | 16 x 19             | 0.50      | 0.50      | 0.75       |
| C   | 015      | –        | 25.50      | 49.00      | 18.75       | 13.50                | 5.88 | 2.25 | 10.50          | 11.25 | 16.00        | 23.50                 | 21.38 | 24.50 | 17 x 20             | 0.75      | 0.75      | 0.75       |
| D   | 018, 024 | 024      | 25.50      | 55.00      | 19.75       | 13.50                | 5.63 | 2.25 | 11.75          | 11.25 | 17.00        | 23.50                 | 24.38 | 27.50 | 18 x 23             | 0.75      | 0.75      | 0.75       |
| E   | 030, 036 | 036      | 28.00      | 68.00      | 21.75       | 16.50                | 5.63 | 2.13 | 13.88          | 13.50 | 19.00        | 26.00                 | 30.88 | 34.00 | 20 x 30             | 1.00      | 1.00      | 0.75       |
| F   | 042, 048 | 048      | 29.38      | 77.75      | 22.13       | 16.50                | 5.63 | 2.50 | 13.88          | 13.50 | 19.25        | 27.25                 | 30.88 | 43.75 | 20 x 20 (x2)        | 1.00      | 1.00      | 0.75       |
| G   | 060, 070 | 060, 070 | 29.38      | 86.75      | 22.13       | 16.50                | 5.63 | 2.50 | 13.88          | 13.50 | 19.25        | 27.25                 | 30.88 | 52.75 | 20 x 20, 20 x 30    | 1.00      | 1.00      | 0.75       |

**Note:** Dimensions represent unit hanging dimensions including base rails for hanging.

## Unit Dimensions

Figure 6. Right return/back supply (EXHK/DXHK)

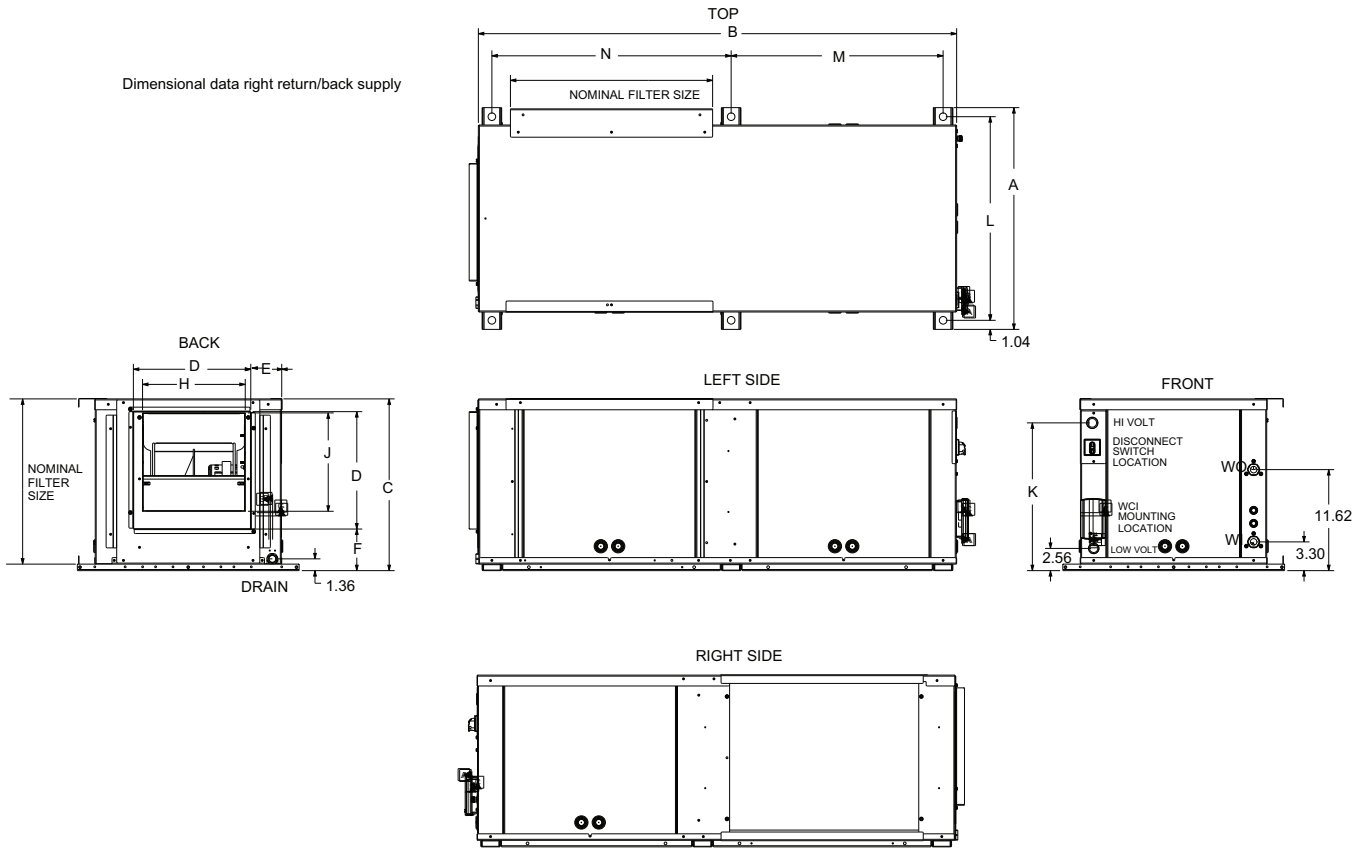
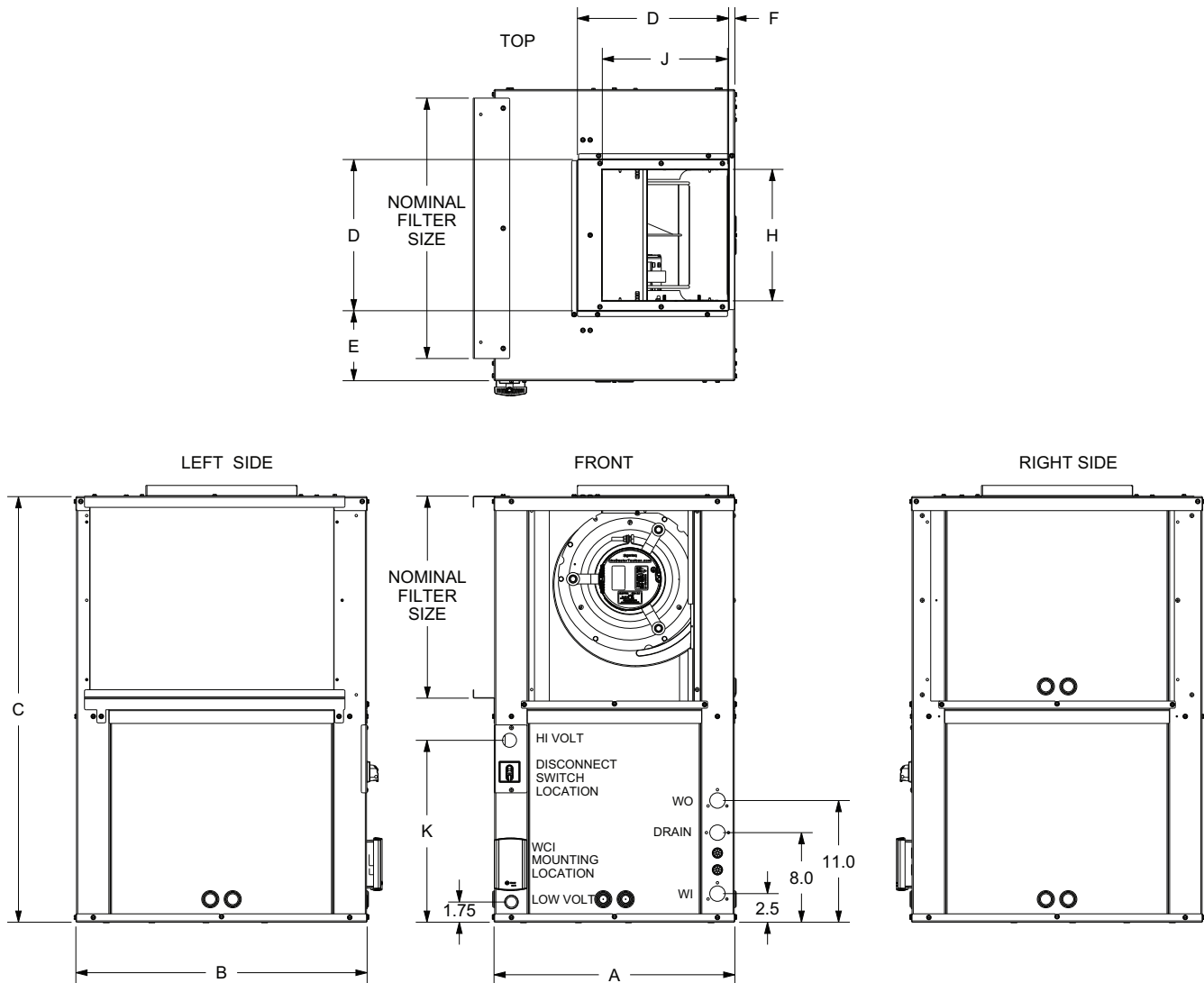


Table 8. Dimensional data right return/back supply (EXHK/DXHK)

| Cab | Unit     |          | Width<br>A | Depth<br>B | Height<br>C | Duct<br>Collar<br>D | Duct Collar<br>Location |      |       | Blower<br>Opening |       | Hi<br>Volt<br>K | Unit hanging<br>location |       |                     | Nominal<br>Filter<br>Size | W.I.<br>NPTI | W.O.<br>NPTI | DRAIN<br>NPTI |
|-----|----------|----------|------------|------------|-------------|---------------------|-------------------------|------|-------|-------------------|-------|-----------------|--------------------------|-------|---------------------|---------------------------|--------------|--------------|---------------|
|     | EXHK     | DXHK     |            |            |             |                     | E                       | F    | H     | J                 | L     |                 | M                        | N     |                     |                           |              |              |               |
| B   | 009, 012 | –        | 25.50      | 46.00      | 17.75       | 13.50               | 3.25                    | 3.00 | 10.13 | 9.38              | 15.00 | 23.50           | 19.88                    | 23.00 | 16 x 19             | 0.50                      | 0.50         | 0.75         |               |
| C   | 015      | –        | 25.50      | 49.00      | 18.75       | 13.50               | 3.88                    | 4.00 | 10.50 | 11.25             | 16.00 | 23.50           | 21.38                    | 24.50 | 17 x 20             | 0.75                      | 0.75         | 0.75         |               |
| D   | 018, 024 | 024      | 25.50      | 55.00      | 19.75       | 13.50               | 3.50                    | 4.75 | 11.75 | 11.25             | 17.00 | 23.50           | 24.38                    | 27.50 | 18 x 23             | 0.75                      | 0.75         | 0.75         |               |
| E   | 030, 036 | 036      | 28.00      | 68.00      | 21.75       | 16.50               | 3.63                    | 3.88 | 13.88 | 13.50             | 19.00 | 26.00           | 30.88                    | 34.00 | 20 x 30             | 1.00                      | 1.00         | 0.75         |               |
| F   | 042, 048 | 048      | 29.38      | 77.75      | 22.13       | 16.50               | 3.50                    | 2.50 | 13.88 | 13.50             | 19.25 | 27.25           | 30.88                    | 43.75 | 20 x 20<br>(x2)     | 1.00                      | 1.00         | 0.75         |               |
| G   | 060, 070 | 060, 070 | 29.38      | 86.75      | 22.13       | 16.50               | 3.50                    | 3.75 | 13.88 | 13.50             | 19.25 | 27.25           | 30.88                    | 52.75 | 20 x 20, 20<br>x 30 | 1.00                      | 1.00         | 0.75         |               |

Note: Units in a free return application will require more than a 1 in. clearance to provide proper airflow to the unit's air-to-refrigerant coil.



**Figure 7. Left return/top supply (EXVK/DXVK)**

**Table 9. Dimensional data left return/top supply (EXVK/DXVK)**

| Cab | Unit     |         | Width<br>A | Depth<br>B | Height<br>C | Duct<br>Collar<br>D | Duct Collar Location |      |      | Blower<br>Opening |       | Hi<br>Volt<br>K | Nominal<br>Filter<br>Size | W.I.<br>NPTI | W.O.<br>NPTI | Drain<br>NPTI |
|-----|----------|---------|------------|------------|-------------|---------------------|----------------------|------|------|-------------------|-------|-----------------|---------------------------|--------------|--------------|---------------|
|     | EXVK     | DXVK    |            |            |             |                     | E                    | F    | G    | H                 | J     |                 |                           |              |              |               |
| B   | 009, 012 | -       | 21.50      | 21.50      | 34.00       | 13.25               | 4.00                 | 1.00 | 3.50 | 10.50             | 9.60  | 14.25           | 16 x 19                   | 0.50         | 0.50         | 0.75          |
| C   | 015      | -       | 21.50      | 23.00      | 36.00       | 13.25               | 4.75                 | 0.63 | 3.50 | 10.50             | 11.30 | 15.25           | 17 x 20                   | 0.75         | 0.75         | 0.75          |
| D   | 018, 024 | 024     | 21.50      | 26.00      | 38.00       | 13.25               | 6.25                 | 0.63 | 3.50 | 11.80             | 11.30 | 16.25           | 18 x 23                   | 0.75         | 0.75         | 0.75          |
| E   | 030,036  | 036     | 24.00      | 32.50      | 42.00       | 16.50               | 7.25                 | 0.75 | 3.50 | 13.70             | 13.50 | 18.25           | 20 x 30                   | 1            | 1            | 0.75          |
| F   | 042, 048 | 048     | 25.40      | 32.50      | 49.00       | 16.50               | 7.25                 | 0.75 | 3.50 | 13.70             | 13.50 | 18.25           | 27 x 30                   | 1            | 1            | 0.75          |
| G   | 060, 070 | 060,070 | 25.40      | 32.50      | 55.00       | 16.50               | 7.25                 | 0.75 | 3.50 | 13.70             | 13.50 | 18.25           | 30 x 33                   | 1            | 1            | 0.75          |

**Note:** Units in a free return application will require more than a 1 in. clearance to provide proper airflow to the unit's air-to-refrigerant coil.



## Unit Dimensions

Figure 8. Right return/top supply (EXVK/DXVK)

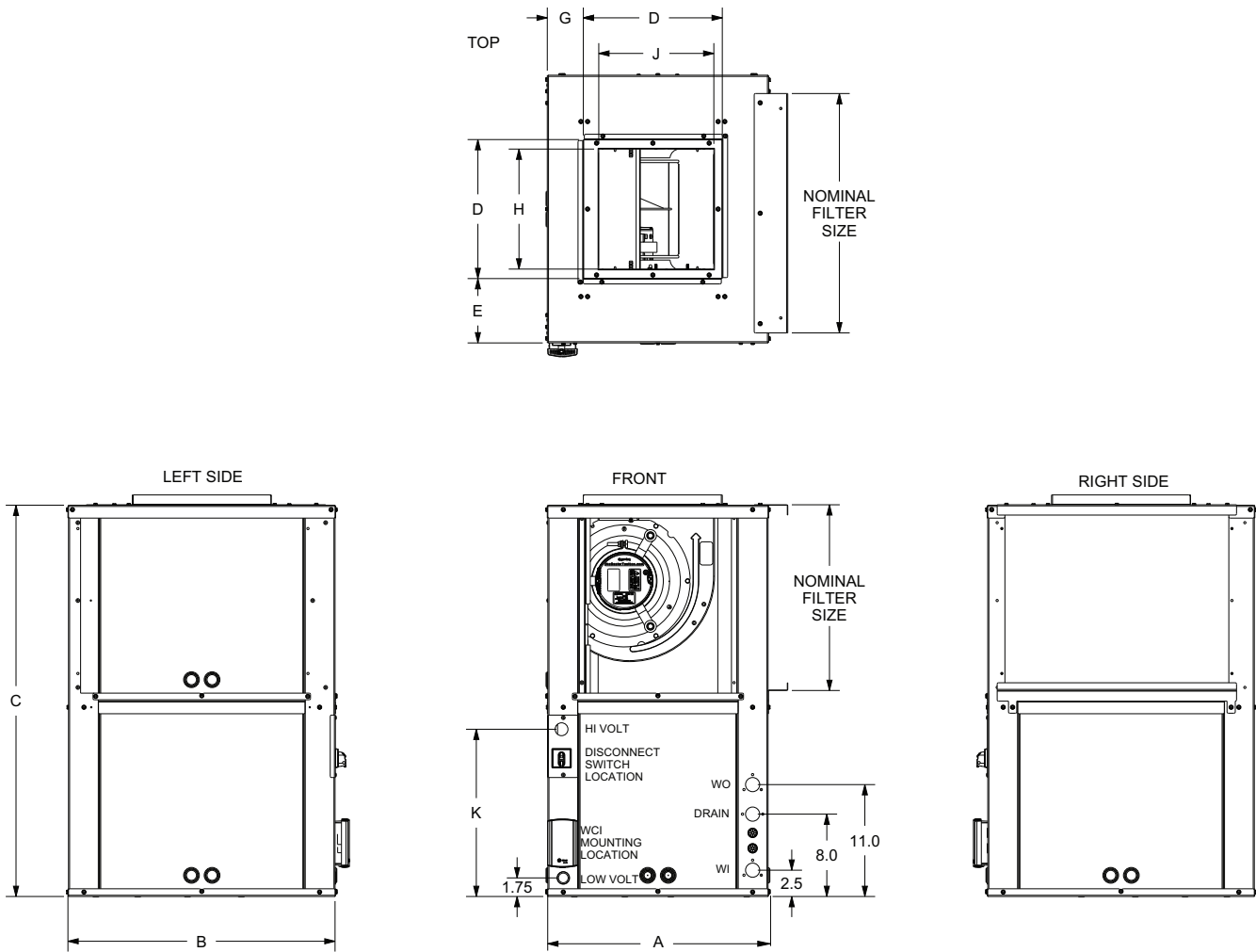
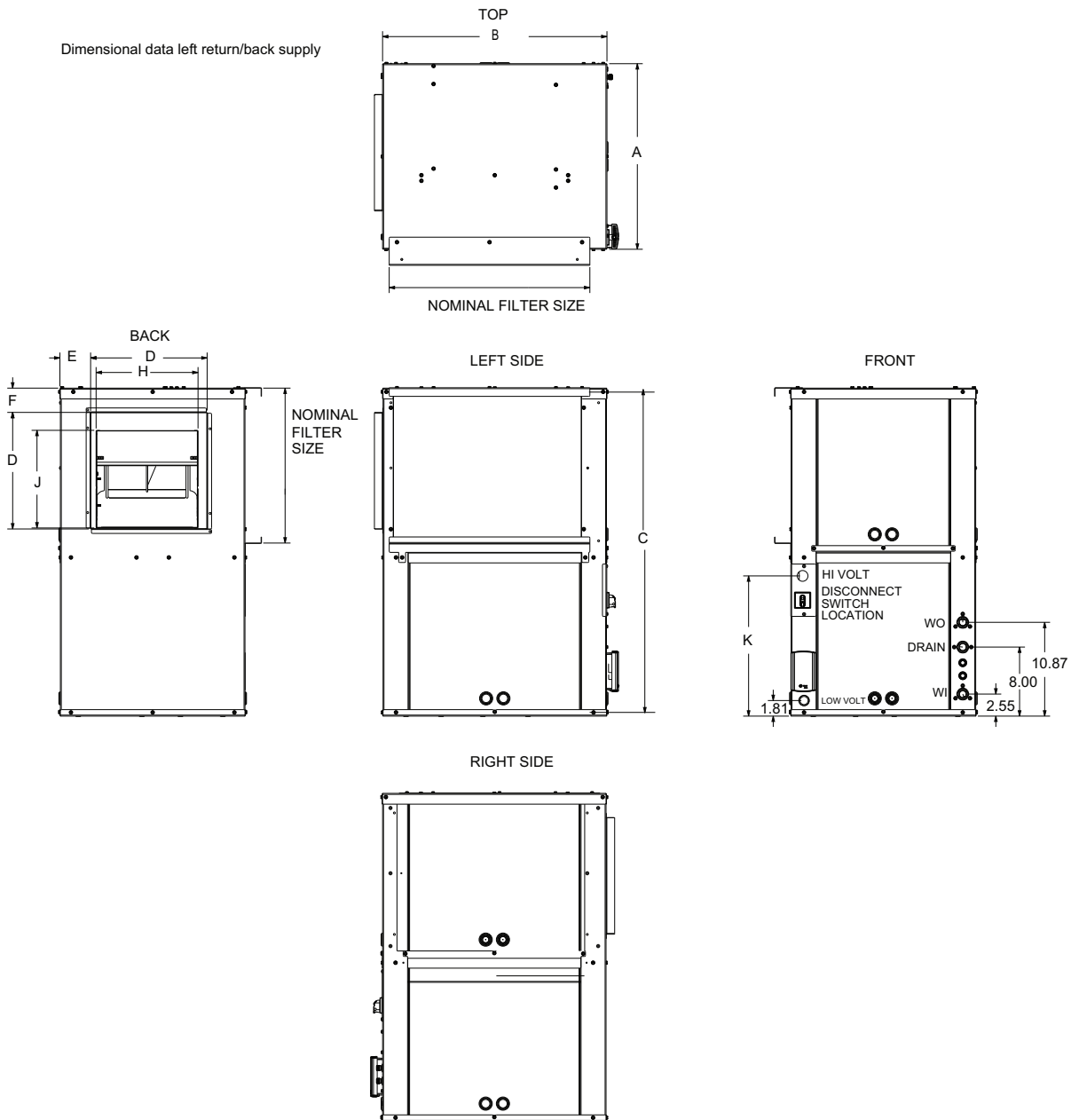


Table 10. Dimensional data right return/top supply (EXVK/DXVK)

| Cab | Unit     |          | Width |       |       | Depth |      |      | Height |       |       | Duct Collar |         | Duct Collar Location |      |      | Blower Opening |  | Hi Volt | Nominal Filter Size | W.I. NPTI | W.O. NPTI | Drain NPTI |
|-----|----------|----------|-------|-------|-------|-------|------|------|--------|-------|-------|-------------|---------|----------------------|------|------|----------------|--|---------|---------------------|-----------|-----------|------------|
|     | EXVK     | DXVK     | A     | B     | C     | D     | E    | F    | G      | H     | J     | K           |         |                      |      |      |                |  |         |                     |           |           |            |
| B   | 009, 012 | -        | 21.50 | 21.50 | 34.00 | 13.25 | 4.00 | 1.00 | 3.50   | 10.50 | 9.60  | 14.25       | 16 x 19 | 0.50                 | 0.50 | 0.75 |                |  |         |                     |           |           |            |
| C   | 015      | -        | 21.50 | 23.00 | 36.00 | 13.25 | 4.75 | 0.63 | 3.50   | 10.50 | 11.30 | 15.25       | 17 x 20 | 0.75                 | 0.75 | 0.75 |                |  |         |                     |           |           |            |
| D   | 018, 024 | 024      | 21.50 | 26.00 | 38.00 | 13.25 | 6.25 | 0.63 | 3.50   | 11.80 | 11.30 | 16.25       | 18 x 23 | 0.75                 | 0.75 | 0.75 |                |  |         |                     |           |           |            |
| E   | 030, 036 | 036      | 24.00 | 32.50 | 42.00 | 16.50 | 7.25 | 0.75 | 3.50   | 13.70 | 13.50 | 18.25       | 20 x 30 | 1                    | 1    | 0.75 |                |  |         |                     |           |           |            |
| F   | 042, 048 | 048      | 25.40 | 32.50 | 49.00 | 16.50 | 7.25 | 0.75 | 3.50   | 13.70 | 13.50 | 18.25       | 27 x 30 | 1                    | 1    | 0.75 |                |  |         |                     |           |           |            |
| G   | 060, 070 | 060, 070 | 25.40 | 32.50 | 55.00 | 16.50 | 7.25 | 0.75 | 3.50   | 13.70 | 13.50 | 18.25       | 30 x 33 | 1                    | 1    | 0.75 |                |  |         |                     |           |           |            |

Note: Units in a free return application will require more than a 1 in. clearance to provide proper air flow to the unit's air-to-refrigerant coil.

**Figure 9. Left return/back supply (EXVK/DXVK)**

**Table 11. Dimensional data left return/back supply (EXVK/DXVK)**

| Cab | Unit     |          | Width<br>A | Depth<br>B | Height<br>C | Duct<br>Collar<br>D | Duct Collar<br>Location |      |       | Blower Opening |       | Hi Volt<br>K | Nominal<br>Filter<br>Size | W.I.<br>NPTI | W.O.<br>NPTI | Drain<br>NPTI |
|-----|----------|----------|------------|------------|-------------|---------------------|-------------------------|------|-------|----------------|-------|--------------|---------------------------|--------------|--------------|---------------|
|     | EXVK     | DXVK     |            |            |             |                     | E                       | F    | H     | J              |       |              |                           |              |              |               |
| B   | 009, 012 | –        | 21.50      | 21.50      | 34.00       | 13.50               | 3.50                    | 2.00 | 10.13 | 9.38           | 14.25 | 16 x 19      | 0.50                      | 0.50         | 0.75         |               |
| C   | 015      | –        | 21.50      | 23.00      | 36.00       | 13.50               | 3.88                    | 2.25 | 10.50 | 11.25          | 15.25 | 17 x 20      | 0.75                      | 0.75         | 0.75         |               |
| D   | 018, 024 | 024      | 21.50      | 26.00      | 38.00       | 13.50               | 3.50                    | 2.75 | 11.75 | 11.25          | 16.25 | 18 x 23      | 0.75                      | 0.75         | 0.75         |               |
| E   | 030, 036 | 036      | 24.00      | 32.50      | 42.00       | 16.50               | 3.63                    | 2.13 | 13.88 | 13.50          | 18.25 | 20 x 30      | 1                         | 1            | 0.75         |               |
| F   | 042, 048 | 048      | 25.40      | 32.50      | 49.00       | 16.50               | 3.50                    | 2.50 | 13.88 | 13.50          | 18.25 | 27 x 30      | 1                         | 1            | 0.75         |               |
| G   | 060, 070 | 060, 070 | 25.40      | 32.50      | 55.00       | 16.50               | 3.50                    | 2.50 | 13.88 | 13.50          | 18.25 | 30 x 33      | 1                         | 1            | 0.75         |               |

**Note:** Units in a free return application will require more than a 1 in. clearance to provide proper air flow to the unit's air-to-refrigerant coil.



## Unit Dimensions

Figure 10. Right return/back supply (EXVK/DXVK)

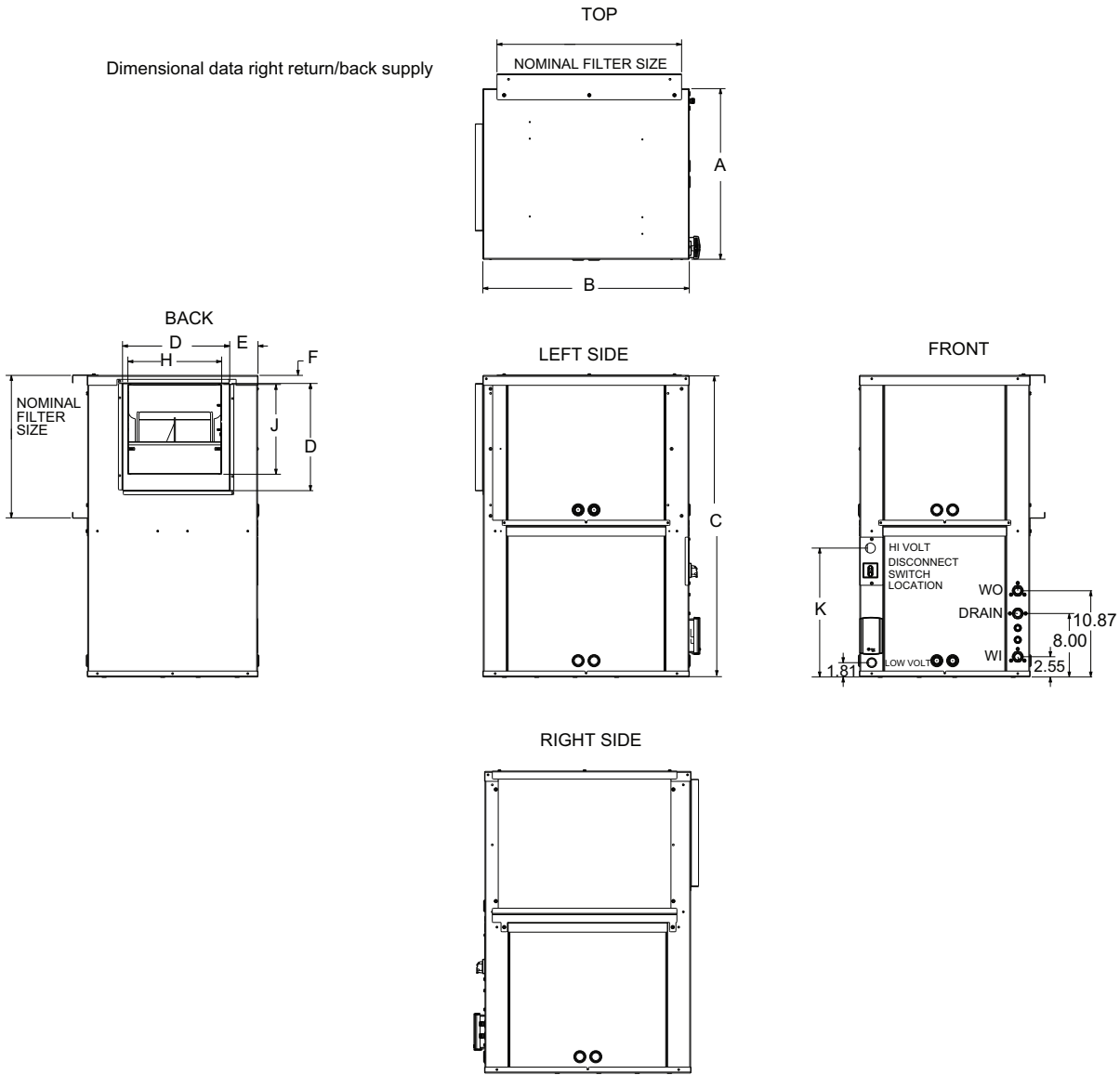
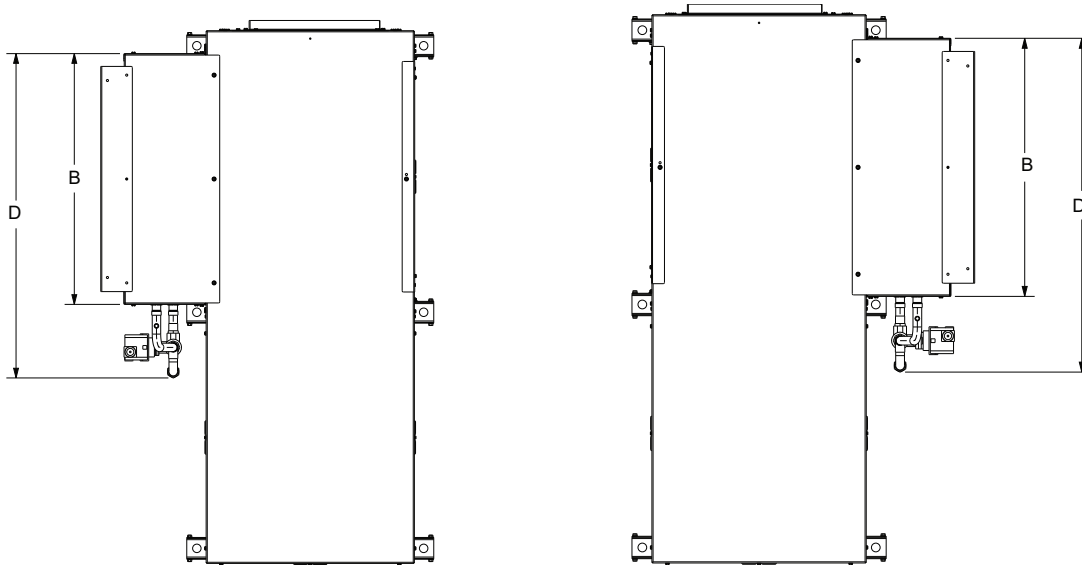


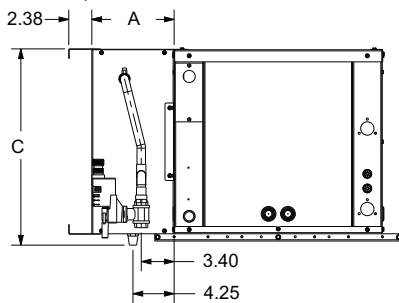
Table 12. Dimensional data right return/back supply (EXVK/DXVK)

| Cab | Unit     |         | Width | Depth | Height | Duct Collar Location |      |      | Blower Opening |       | Hi Volt | Nominal Filter Size | W.I. NPTI | W.O. NPTI | Drain NPTI |
|-----|----------|---------|-------|-------|--------|----------------------|------|------|----------------|-------|---------|---------------------|-----------|-----------|------------|
|     | EXVK     | DXVK    | A     | B     | C      | D                    | E    | F    | H              | J     | K       |                     |           |           |            |
| B   | 009, 012 | –       | 21.50 | 21.50 | 34.00  | 13.50                | 3.25 | 1.00 | 10.13          | 9.38  | 14.25   | 16 x 19             | 0.50      | 0.50      | 0.75       |
| C   | 015      | –       | 21.50 | 23.00 | 36.00  | 13.50                | 3.88 | 1.00 | 10.50          | 11.25 | 15.25   | 17 x 20             | 0.75      | 0.75      | 0.75       |
| D   | 018, 024 | 024     | 21.50 | 26.00 | 38.00  | 13.50                | 3.50 | 1.00 | 11.75          | 11.25 | 16.25   | 18 x 23             | 0.75      | 0.75      | 0.75       |
| E   | 030,036  | 036     | 24.00 | 32.50 | 42.00  | 16.50                | 3.63 | 1.00 | 13.88          | 13.50 | 18.25   | 20 x 30             | 1         | 1         | 0.75       |
| F   | 042, 048 | 048     | 25.40 | 32.50 | 49.00  | 16.50                | 3.50 | 1.00 | 13.88          | 13.50 | 18.25   | 27 x 30             | 1         | 1         | 0.75       |
| G   | 060, 070 | 060,070 | 25.40 | 32.50 | 55.00  | 16.50                | 3.50 | 1.00 | 13.88          | 13.50 | 18.25   | 30 x 33             | 1         | 1         | 0.75       |

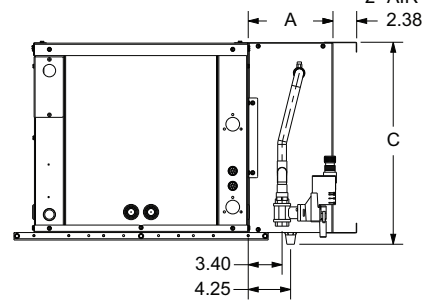
Note: Units in a free return application will require more than a 1 in. clearance to provide proper air flow to the unit's air-to-refrigerant coil.

**Figure 11. Waterside economizer<sup>1</sup> (EXHK/DXHK)**


2" AIR FILTER (1.38 FOR 1")



2" AIR FILTER (1.38 FOR 1")


**Table 13. Dimensional data waterside economizer (EXHK/DXHK)**

| Cab | Unit |     |      |     | WSE Dimensions |       |        |                    | Pipe Size |      |
|-----|------|-----|------|-----|----------------|-------|--------|--------------------|-----------|------|
|     |      |     |      |     | Width          | Depth | Height | Depth W/<br>Piping | A         | B    |
|     | EXHK |     | DXHK |     | A              | B     | C      | D                  | NPTI      | NPTI |
| B   | 009  | 012 | –    | –   | 8.5            | 21.5  | 18.25  | 29.00              | 0.50      | 0.50 |
| C   | 015  | –   | –    | –   |                | 23.0  | 19.25  | 30.50              | 0.75      | 0.75 |
| D   | 018  | 024 | 024  | –   |                | 26.0  | 22.25  | 33.50              | 0.75      | 0.75 |
| E   | 030  | 036 | 036  | –   |                | 32.5  |        | 38.25              | 1         | 1    |
| F   | 042  | 048 | 048  | –   |                |       | 29.25  | 50.50              | 1         | 1    |
| G   | 060  | 070 | 060  | 070 |                |       | 35.25  | 59.50              | 1         | 1    |

**Table 14. Waterside economizer weights and part numbers - horizontal**

| Unit Model        | Waterside Economizer | Weight w/out H <sub>2</sub> O | Weight w/H <sub>2</sub> O |
|-------------------|----------------------|-------------------------------|---------------------------|
| EXHK009-012 LR    | WSHPECN00016         | 27                            | 30                        |
| EXHK015 LR        | WSHPECN00017         | 29                            | 33                        |
| EX/DXHK018-024 LR | WSHPECN00018         | 35                            | 40                        |
| EX/DXHK030-036 LR | WSHPECN00019         | 41                            | 48                        |
| EX/DXHK042-048 LR | WSHPECN00020         | 50                            | 59                        |

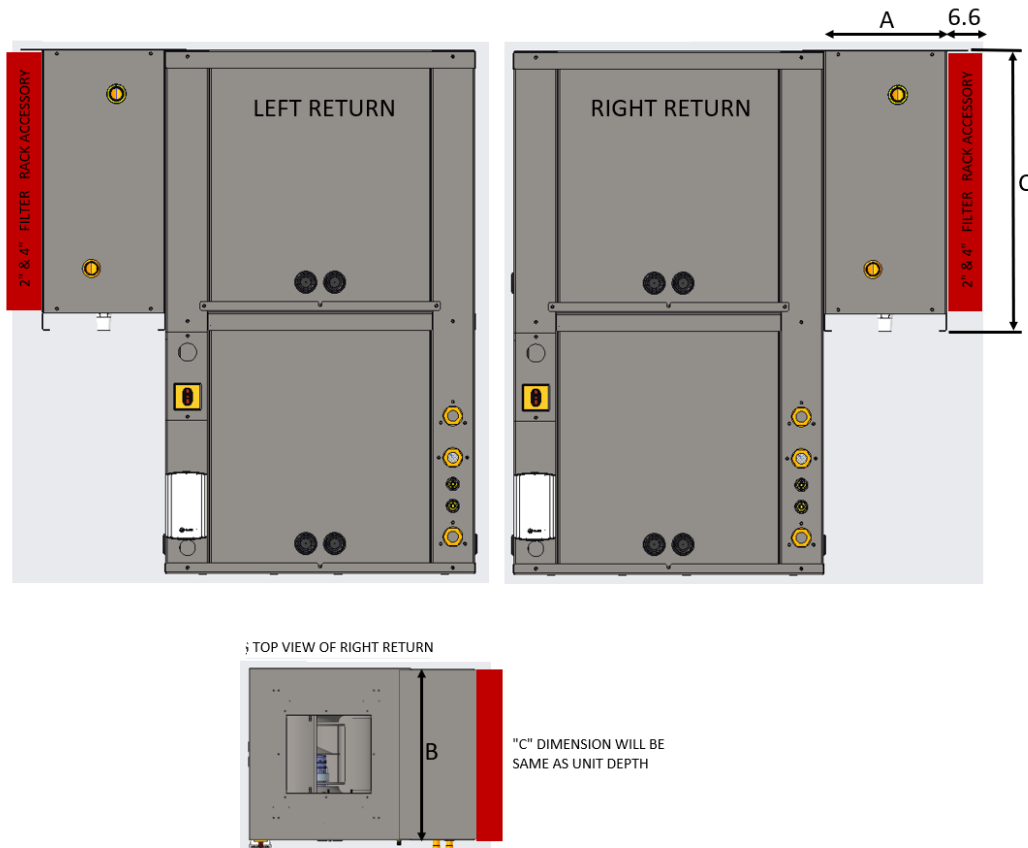
<sup>1</sup> Waterside economizer installation requires field piping.

## Unit Dimensions

**Table 14. Waterside economizer weights and part numbers - horizontal (continued)**

| Unit Model        | Waterside Economizer | Weight w/out H <sub>2</sub> O | Weight w/H <sub>2</sub> O |
|-------------------|----------------------|-------------------------------|---------------------------|
| EX/DXHK060-070 LR | WSHPECN00021         | 59                            | 70                        |
| EXHK009-012 RR    | WSHPECN00023         | 27                            | 30                        |
| EXHK015 RR        | WSHPECN00024         | 29                            | 33                        |
| EX/DXHK018-024 RR | WSHPECN00025         | 35                            | 40                        |
| EX/DXHK030-036 RR | WSHPECN00026         | 41                            | 48                        |
| EX/DXHK042-048 RR | WSHPECN00027         | 50                            | 59                        |
| EX/DXHK060-070 RR | WSHPECN00028         | 59                            | 70                        |

**Figure 12. Waterside economizer (EXVK/DXVK)**

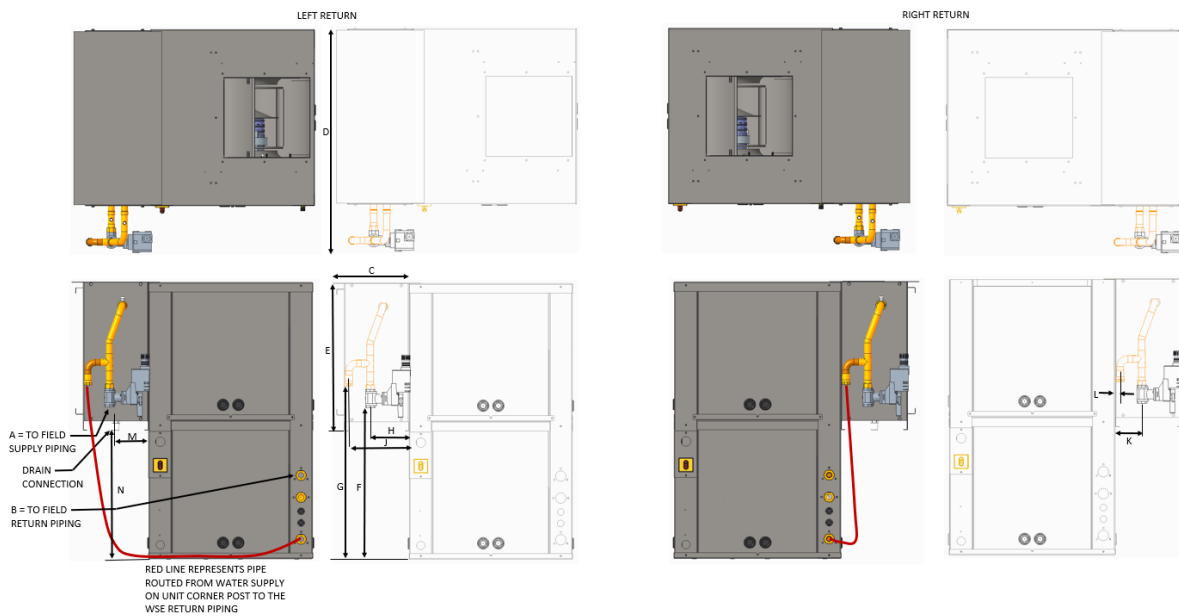


**Table 15. Dimensional data waterside economizer (EXVK/DXVK)**

| Unit        | Cabinet | WSE Dimensions |              |               |
|-------------|---------|----------------|--------------|---------------|
|             |         | A<br>(Width)   | B<br>(Depth) | C<br>(Height) |
| EXVK009-012 | B       | 8.5            | 21.5         | 18.25         |
| EXVK015     | C       | 8.5            | 23.0         | 19.25         |

**Table 15. Dimensional data waterside economizer (EXVK/DXVK) (continued)**

| Unit                 | Cabinet | WSE Dimensions |              |               |
|----------------------|---------|----------------|--------------|---------------|
|                      |         | A<br>(Width)   | B<br>(Depth) | C<br>(Height) |
| EXVK018-024, DXVK024 | D       | 8.5            | 26.0         | 22.25         |
| EXVK030-036, DXVK036 | E       | 8.5            | 32.5         | 22.25         |
| EXVK042-048, DXVK048 | F       | 8.5            | 32.5         | 29.25         |
| EXVK/DXVK060-070     | G       | 8.5            | 32.5         | 35.25         |

**Figure 13. Waterside economizer (EXVK/DXVK)**

**Table 16. Dimensional data waterside economizer (EXVK/DXVK)**

| Unit                    | Cabinet | Pipe Size |           | WSE Size   |            |             | Piping Location |             |            |            |            |            | Drain      |             |
|-------------------------|---------|-----------|-----------|------------|------------|-------------|-----------------|-------------|------------|------------|------------|------------|------------|-------------|
|                         |         | A<br>NPTI | B<br>NPTI | C<br>Width | D<br>Depth | E<br>Height | F<br>Height     | G<br>Height | H<br>Width | J<br>Width | K<br>Width | L<br>Width | M<br>Width | N<br>Height |
| EXVK009-012             | B       | 0.50      | 0.50      | 8.5        | 27.5       | 18.25       | 17.75           | 20.75       | 5.0        | 7.88       | 3.5        | 0.63       | 4.25       | 15.75       |
| EXVK015                 | C       | 0.75      | 0.75      | 8.5        | 29.0       | 19.25       | 19.75           | 22.75       | 5.0        | 7.88       | 3.5        | 0.63       | 4.25       | 16.75       |
| EXVK018-024,<br>DXVK024 | D       | 0.75      | 0.75      | 8.5        | 32.0       | 21.75       | 21.75           | 24.75       | 5.0        | 7.88       | 3.5        | 0.63       | 4.25       | 15.75       |
| EXVK030-036,<br>DXVK036 | E       | 1         | 1         | 8.5        | 38.5       | 22.75       | 22.75           | 25.75       | 5.0        | 8          | 3.5        | 0.5        | 4.25       | 19.75       |
| EXVK042-048,<br>DXVK048 | F       | 1         | 1         | 8.5        | 38.5       | 22.75       | 22.75           | 25.75       | 5.0        | 8          | 3.5        | 0.5        | 4.25       | 19.75       |
| EXVK/DXVK060-070        | G       | 1         | 1         | 8.5        | 38.5       | 22.75       | 22.75           | 25.75       | 5.0        | 8          | 3.5        | 0.5        | 4.25       | 19.75       |



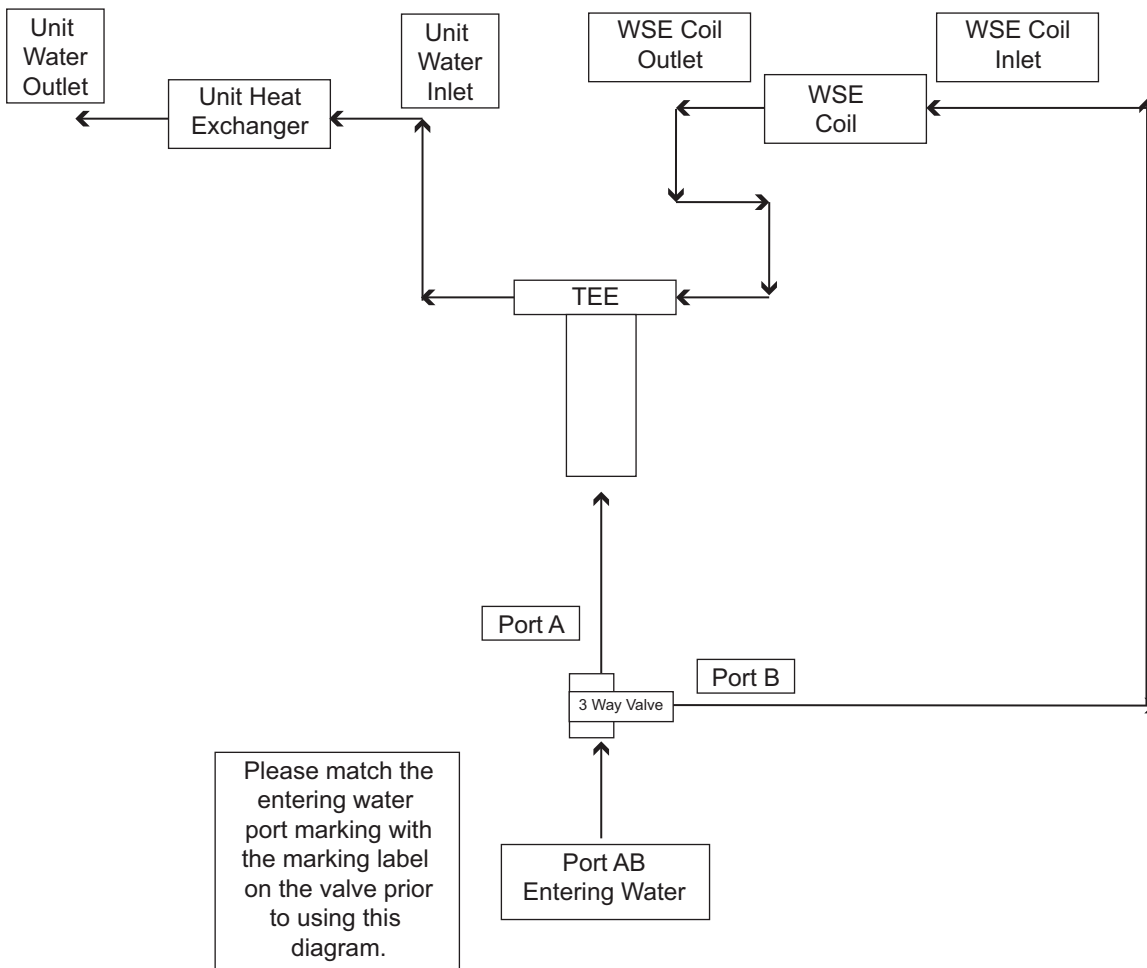


## Unit Dimensions

**Table 17. Waterside economizer weights and part numbers - vertical**

| Unit Model        | Waterside Economizer | Weight w/out H <sub>2</sub> O (lbs) | Weight w/H <sub>2</sub> O (lbs) |
|-------------------|----------------------|-------------------------------------|---------------------------------|
| EXVK009-012 LR    | WSHPECN00002         | 27                                  | 30                              |
| EXVK015 LR        | WSHPECN00003         | 29                                  | 33                              |
| EX/DXVK018-024 LR | WSHPECN00004         | 35                                  | 40                              |
| EX/DXVK030-036 LR | WSHPECN00005         | 41                                  | 48                              |
| EX/DXVK042-048 LR | WSHPECN00006         | 51                                  | 60                              |
| EX/DXVK060-070 LR | WSHPECN00007         | 60                                  | 71                              |
| EXVK009-012 RR    | WSHPECN00009         | 27                                  | 30                              |
| EXVK015 RR        | WSHPECN00010         | 29                                  | 33                              |
| EX/DXVK018-024 RR | WSHPECN00011         | 35                                  | 40                              |
| EX/DXVK030-036 RR | WSHPECN00012         | 41                                  | 48                              |
| EX/DXVK042-048 RR | WSHPECN00013         | 51                                  | 60                              |
| EX/DXVK060-070 RR | WSHPECN00014         | 60                                  | 71                              |

**Figure 14. Waterside economizer coil piping diagram**





# Weights

**Table 18. Unit weights DXH 2 to 6 tons (Approximate)**

| DXH | Shipping Weight with pallet (lbs) | Unit Weight without pallet (lbs) |
|-----|-----------------------------------|----------------------------------|
| 024 | 393                               | 269                              |
| 036 | 458                               | 313                              |
| 048 | 560                               | 381                              |
| 060 | 613                               | 434                              |
| 070 | 613                               | 434                              |

**Table 19. Unit weights DXVK 2 to 6 tons (Approximate)**

| DXV | Shipping Weight with pallet (lbs) | Unit Weight without pallet (lbs) |
|-----|-----------------------------------|----------------------------------|
| 024 | 296                               | 236                              |
| 036 | 342                               | 279                              |
| 048 | 419                               | 354                              |
| 060 | 440                               | 371                              |
| 070 | 506                               | 437                              |

**Table 20. Unit weights EXVK 0.75 to 6 tons (Approximate)**

| EXV (60 Hz) | Shipping Weight with pallet (lbs) | Unit Weight without pallet (lbs) |
|-------------|-----------------------------------|----------------------------------|
| 009         | 207                               | 152                              |
| 012         | 207                               | 152                              |
| 015         | 246                               | 188                              |
| 018         | 282                               | 222                              |
| 024         | 296                               | 236                              |
| 030         | 343                               | 280                              |
| 036         | 344                               | 281                              |
| 042         | 394                               | 329                              |
| 048         | 410                               | 374                              |
| 060         | 436                               | 394                              |
| 070         | 501                               | 432                              |

**Table 21. Unit weights EXH 0.75 to 6 tons (Approximate)**

| EXH (60 Hz) | Shipping Weight with pallet (lbs) | Unit Weight without pallet (lbs) |
|-------------|-----------------------------------|----------------------------------|
| 009         | 297                               | 173                              |
| 012         | 297                               | 173                              |

**Table 21. Unit weights EXH 0.75 to 6 tons (Approximate) (continued)**

| EXH (60 Hz) | Shipping Weight with pallet (lbs) | Unit Weight without pallet (lbs) |
|-------------|-----------------------------------|----------------------------------|
| 015         | 297                               | 173                              |
| 018         | 393                               | 269                              |
| 024         | 393                               | 269                              |
| 030         | 458                               | 313                              |
| 036         | 458                               | 313                              |
| 042         | 560                               | 381                              |
| 048         | 560                               | 381                              |
| 060         | 613                               | 434                              |
| 070         | 613                               | 434                              |

## Weight Distribution for Hanging the DXH and EXH Model

**⚠ WARNING**

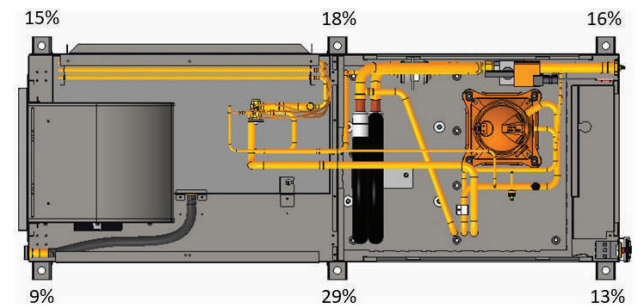
**Improper Unit Lift!**

Failure to properly lift unit in a LEVEL position could result in unit dropping and possibly crushing operator/technician which could result in death or serious injury, and equipment or property-only damage.

Test lift unit approximately 24 inches (61 cm) to verify proper center of gravity lift point. To avoid dropping of unit, reposition lifting point if unit is not level.

Approximate weight distribution for proper hanging of the unit is indicated by weight distribution in the figure below. Tolerance on the weights determined are  $\pm 15\%$ .

**Figure 15. Weight distribution DXH 2 to 6 tons; EXH 0.75 to 6 tons**





# A2L Information and Installation Requirements

## Installation/Code Compliance Requirements

Building level controls may need to be upgraded/modified to demand leak mitigation actions as described in “[Leak Detection System](#) (Refrigerant charge greater than 3.91 lb per circuit),” p. 33. Those actions include, but are not limited to, fully opening damper and VAV boxes (if present), and disabling electric heat in VAV boxes (if present).

Verify the equipment refrigerant charge is in accordance with the room area limitation as described in Minimum Room Area Limits section.

Ensure that there are labels on the equipment stating it contains a flammable refrigerant.

## A2L Work Procedures

### ⚠ WARNING

#### Risk of Fire — Flammable Refrigerant!

Failure to follow instructions below could result in death or serious injury, and equipment damage.

- To be repaired only by trained service personnel.
- Do not puncture refrigerant tubing.
- Dispose of properly in accordance with federal or local regulations.
- The equipment shall be stored in a room without continuously operating ignition sources.

### ⚠ WARNING

#### Refrigerant under High Pressure!

Failure to follow instructions below could result in an explosion which could result in death or serious injury or equipment damage.

System contains refrigerant under high pressure. Recover refrigerant to relieve pressure before opening the system. See unit nameplate for refrigerant type. Do not use non-approved refrigerants, refrigerant substitutes, or refrigerant additives.

### ⚠ WARNING

#### Hazardous Voltage!

Failure to disconnect power before servicing could result in death or serious injury.

Disconnect all electric power, including remote disconnects before servicing. Follow proper lockout/tagout procedures to ensure the power can not be inadvertently energized. Verify that no power is present with a voltmeter.

The units described in this manual use R-454B refrigerant. Use ONLY R-454B rated service equipment or components with these units. For specific handling concerns with R-454B, contact your local Trane representative.

Installation, repair, removal, or disposal should be performed by trained service personnel.

At all times, Trane’s maintenance and service guidelines shall be followed. If in doubt, contact Trane technical support for assistance.

## Servicing

Prior to initiating work on equipment, check the area with an appropriate refrigerant detector. Ensure the service personnel are properly trained regarding work in potentially toxic or flammable atmospheres. Ensure that the leak detection equipment being used is suitable for use with all applicable refrigerants, i.e. non-sparking, adequately sealed, or intrinsically safe. Be aware that the refrigerant does not contain an odor.

If any hot work is to be conducted on the refrigerating equipment or any associated parts, appropriate fire extinguishing equipment shall be available on hand. A dry powder or CO<sub>2</sub> fire extinguisher should be located adjacent to the charging area.

At all times, Trane’s maintenance and service guidelines shall be followed. If in doubt, contact Trane technical support for assistance.

All maintenance staff and others working in the local area shall be instructed on the nature of the work being carried out. Work in confined spaces shall be avoided.

## Ignition Source Mitigation

Do not use any sources of ignition when working on the refrigeration system.

Keep all ignition sources, including cigarette smoking, away from the site of installation, repair, removal or disposal, during which refrigerant can potentially be released to the surrounding space.

Survey the area around the equipment before initiating work to ensure no flammable hazards or ignition risks are present.

“No Smoking” signs shall be displayed.

Do not use devices that can be a source of ignition to accelerate defrosting of components. Use only defrost and cleaning procedures recommended by Trane. Do not pierce or burn.

### **Ventilation**

Ensure that the area is in the open or that it is adequately ventilated before breaking into the system or conducting any hot work. A degree of ventilation shall continue during the period that the work is carried out. The ventilation should safely disperse any released refrigerant and preferably expel it externally into the atmosphere. If present, check that the ventilation system, including outlets, are operating adequately and are not obstructed.

### **Refrigerating Equipment**

Refrigerant piping or components should not be installed in locations where substances which may corrode them are present.

Check that equipment hazard markings are visible and legible. Replace them if they are not.

For equipment using secondary fluids, like water or glycol, check that refrigerant is not present in the secondary fluid loop before conducting any hot work.

### **Electrical Devices**

Do not apply power to the circuit if a fault exists which compromises safety. If the fault cannot be corrected immediately, but it is necessary to continue operation, an adequate temporary solution shall be used. This shall be reported to the owner of the equipment, so all parties are advised.

Initial safety checks shall include:

- Cabling is not subject to wear, corrosion, excessive pressure, vibration, sharp edges, or any other adverse environmental effects. Account for the effects of aging or continual vibration from sources such as compressors or fans.
- Capacitors are discharged. This shall be done in a safe manner to avoid possibility of sparking.
- No live electrical components and wiring are exposed while charging, recovering, or purging the system.
- Verify continuity of earth bonding.
- Replace electrical components with Trane replacement parts, or those meeting the same ratings and qualified for flame arrest protection, UL LZGH2 category.

### **Leak Detection**

Never use an open flame to detect leaks. A halide torch should not be used. Use only approved leak detection methods per this instruction manual.

The following leak detection methods are deemed acceptable for all refrigerant systems.

Electronic leak detectors may be used to detect refrigerant leaks but, in the case of flammable refrigerants, the sensitivity may not be adequate, or may need re-

calibration. (Detection equipment shall be calibrated in a refrigerant-free area.) Ensure that the detector is not a potential source of ignition and is suitable for the refrigerant used. Leak detection equipment shall be set at a percentage of the LFL gas (25% maximum) is confirmed.

Leak detection fluids are also suitable for use with most refrigerants but the use of detergents containing chlorine shall be avoided as the chlorine may react with the refrigerant and corrode the copper pipe-work.

Examples of leak detection fluids are:

- Bubble method
- Fluorescent method agents

If a leak is suspected, all naked flames shall be removed/ extinguished.

If a refrigerant leak is found which requires brazing, all refrigerant shall be recovered from the system, or isolated (by means of shut off valves) in a part of the system remote from the leak.

### **Refrigerant Removal and Evacuation**

Ensure that the correct number of cylinders for holding the total system charge is available. All cylinders to be used are designated for the recovered refrigerant and labeled for that refrigerant (special cylinders for the recovery of refrigerant, for example). Cylinders shall be complete with pressure-relief valve and associated shut-off valves in good working order. Empty recovery cylinders are evacuated and, if possible, cooled before recovery occurs.

When breaking into the refrigerant circuit to make repairs – or for any other purpose – conventional procedures shall be used. However, for flammable refrigerants it is important that best practice be followed, since flammability is a consideration.

The following procedure shall be adhered to:

1. Safely remove refrigerant following local and national regulations.
2. Evacuate.
3. Purge the circuit with inert gas.
4. Evacuate (optional for A2L).
5. Continuously flush or purge with inert gas when using flame to open circuit.
6. Open the circuit.

Prior to refrigerant removal, open all appropriate valves, including solenoid and electronic expansion valves (EXVs). Use control settings, where available. When not available, manually open all electronically controlled valves using acceptable service procedures.

The recovery equipment shall be in good working order with instructions available. Equipment shall be suitable for the recovery of the flammable refrigerant. For specific handling concerns, contact the manufacturer. Ensure all hose connections are checked for tightness to avoid refrigerant leaks.



## A2L Information and Installation Requirements

In addition, a set of calibrated weighing scales shall be available and in good working order.

The refrigerant shall be recovered into the correct recovery cylinders if venting is not allowed by local and national codes. Do not mix refrigerants in recovery unit and especially not in cylinders.

Refrigerant recovery unit should be purged with an inert gas after each use or before using with a different refrigerant Class – for example, A2L to A1.

If compressors or compressor oils are to be removed, ensure that they have been evacuated to an acceptable level to make certain that flammable refrigerant does not remain within the lubricant. The compressor body shall not be heated by an open flame or other ignition sources to accelerate this process. When oil is drained from a system, it shall be carried out safely.

The system shall be purged with oxygen-free nitrogen to render the appliance safe for flammable refrigerants. This process might need to be repeated several times. Compressed air or oxygen shall not be used for purging refrigerant systems.

The system shall be vented down to atmospheric pressure to enable work to take place.

The outlet for the vacuum pump shall not be close to any potential ignition sources, and ventilation shall be available.

### Refrigerant Charging

In addition to conventional charging procedures, the following requirements shall be followed.

- Ensure that contamination of different refrigerants does not occur when using charging equipment.
- Hoses or lines shall be as short as possible to minimize the amount of refrigerant contained in them.
- Cylinders shall be kept in an appropriate position according to the instructions.
- Ensure that the refrigerating system is earthed prior to charging the system with refrigerant.
- Label the system when charging is complete (if not already).
- Extreme care shall be taken not to overfill the refrigerating system.

Prior to recharging the system, it shall be pressure-tested with the appropriate purging gas. The system shall be leak-tested on completion of charging but prior to commissioning. A follow up leak test shall be carried out prior to leaving the site.

Prior to refrigerant charging, open all appropriate valves, including solenoid and electronic expansion valves (EXVs). Use control settings, where available. When not available, manually open all electronically controlled valves using acceptable service procedures.

Verify the equipment refrigerant charge is in accordance with the room area limitation as described in Minimum Room Area Limits section.

### Decommissioning

Before carrying out the decommissioning procedure, it is essential that the trained service personnel is completely familiar with the equipment and all its details. It is recommended good practice that all refrigerants are recovered safely. Prior to the task being carried out, an oil and refrigerant sample shall be taken in case analysis is required prior to re-use of recovered refrigerant. It is essential that electrical power is available before the task is commenced.

1. Become familiar with the equipment and its operation.
2. Isolate system electrically.
3. Before attempting the procedure, ensure that:
  - a. Mechanical handling equipment is available, if required, for handling refrigerant cylinders.
  - b. All personal protective equipment is available and being used correctly.
  - c. The recovery process is supervised at all times by a competent person.
  - d. Recovery equipment and cylinders conform to the appropriate standards.
4. Pump down refrigerant system, if possible.
5. If a vacuum is not possible, make a manifold so that refrigerant can be removed from various parts of the system.
6. Make sure that cylinder is situated on the scales before recovery takes place.
7. Start the recovery machine and operate in accordance with instructions.
8. Do not overfill cylinders (no more than 80% volume liquid charge).
9. Do not exceed the maximum working pressure of the cylinder, even temporarily.
10. When the cylinders have been filled correctly and the process completed, make sure that the cylinders and the equipment are removed from site promptly and all isolation valves on the equipment are closed off.
11. Recovered refrigerant shall not be charged into another refrigerating system unless it has been cleaned and checked.
12. When equipment has been decommissioned, attach a signed and dated label stating it has been decommissioned and emptied of refrigerant.
13. Ensure that there are labels on the equipment stating it contains flammable refrigerant.

### A2L Application Considerations

This product is listed to UL standard 60335-2-40, Household and Similar Electrical Appliances – Safety – Part 2-40: Particular Requirements for Electrical Heat Pumps, Air-Conditioners and Dehumidifiers, which defines safe design and use strategies for equipment using A2L

refrigerants. This standard limits the refrigerant concentration in a space in the event of a refrigerant leak. To meet the requirements, the UL standard defines minimum room area, refrigerant charge limit, minimum circulation airflow and/or ventilation airflow requirements, and limits the use of ignition sources in spaces. The standard may require a unit refrigerant leak detection system.

For equipment with R-454B and charge amounts less than or equal to 3.91 lbs per circuit, this UL standard does not prescribe a room area limit and does not require a refrigerant leak detection system or any circulation airflow or ventilation airflow mitigation strategies. However, ignition sources in ductwork must be evaluated.

Depending on the application, a specific requirement of ANSI/ASHRAE Standard 15, Safety Standard for Refrigeration Systems, could be more stringent than UL 60335-2-40 requirements. See *Refrigeration Systems and Machinery Rooms Application Considerations for Compliance with ASHRAE® Standard 15-2022 Application Engineering Manual* (APP-APM001\*-EN) for more information.

### Ignition Sources in Ductwork

Do not install open flames in the ductwork. Hot surfaces exceeding 700°C (1290°F) should not be installed in the ductwork unless the average airflow velocity is not less than 1.0 m/s (200 ft/min) across the heater and proof of airflow is verified before system is energized.

Electric heaters can exceed the surface temperature limit if airflow distribution is poor, or insufficient airflow is provided over the heater.

Surface temperatures of most gas heaters do not exceed the surface temperature limits due to ANSI construction requirements.

### Ignition Sources in Unit

This unit does not contain any ignition sources. All potential ignition sources, (including factory or field installed accessory electric heaters, gas heaters, relays, and contactors) were evaluated during product UL listing.

### Minimum Room Area Limits (Refrigerant charge greater than 3.91 lb per circuit)

Equipment with R-454B charge amounts greater than 3.91 lb per circuit may require additional circulation or ventilation airflow mitigation strategies. In this case, two minimum room area ( $A_{min}$ ) thresholds:

- The first threshold defines when equipment serving a single room is required to provide circulation airflow, either continuous or activated by a leak detection system. A ducted system requires circulation airflow unless the smallest room it serves is larger than the adjusted  $A_{min}$  threshold. This product contains a leak detection system if a circuit charge is greater than 3.91 lbs. As a result, no further leak detection system evaluation is required.
- The second threshold defines when additional ventilation airflow is required. If the room area,  $A$  or  $TA$ , is below the adjusted  $A_{min}$  or  $TA_{min}$  threshold, additional ventilation is required to remove refrigerant in the event of a leak. Refer to UL 60335-2-40 Clause GG.8 and ANSI/ASHRAE Standard 15 Section 7 for natural and mechanical ventilation requirements.

**Table 22. Minimum room area — vertical**

| Models  | Minimum Room Area (m <sup>2</sup> )<br>0.6 meters height | Minimum Room Area (ft <sup>2</sup> )<br>1.9 feet height |
|---------|--|---|
| EXVK009 | 11.2   | 120.3   |
| EXVK012 | 10.9   | 116.8   |
| EXVK015 | 11.3   | 122.0   |
| EXVK018 | 15.2   | 163.2   |
| EXVK024 | 16.0   | 171.8   |
| EXVK030 | 19.3   | 207.9   |
| EXVK036 | 19.8   | 213.1   |
| EXVK042 | 24.3   | 261.2   |
| EXVK048 | 24.9   | 268.0   |
| EXVK060 | 28.4   | 305.8   |
| EXVK070 | 33.5   | 360.8   |
| DXVK024 | 16.6   | 178.7   |
| DXVK036 | 19.0   | 204.5   |
| DXVK048 | 24.6   | 264.6   |



## A2L Information and Installation Requirements

**Table 22. Minimum room area — vertical (continued)**

| Models  | Minimum Room Area (m <sup>2</sup> )<br>0.6 meters height | Minimum Room Area (ft <sup>2</sup> )<br>1.9 feet height |
|---------|--|---|
| DXVK060 | 29.4   | 316.1   |
| DXVK070 | 33.5   | 360.8   |

**Table 23. Minimum room area — horizontal**

| Models  | Minimum Room Area (m <sup>2</sup> )<br>2.2 meters height | Minimum Room Area (ft <sup>2</sup> )<br>7.2 feet height |
|---------|--|---|
| EXHK009 | 3.0  | 32.8  |
| EXHK012 | 3.0  | 31.9  |
| EXHK015 | 3.1  | 33.3  |
| EXHK018 | 4.1  | 44.5  |
| EXHK024 | 4.4  | 46.9  |
| EXHK030 | 5.3  | 56.7  |
| EXHK036 | 5.4  | 58.1  |
| EXHK042 | 6.6  | 71.2  |
| EXHK048 | 6.8  | 73.1  |
| EXHK060 | 7.7  | 83.4  |
| EXHK070 | 9.1  | 98.4  |
| DXHK024 | 4.5  | 48.7  |
| DXHK036 | 5.2  | 55.8  |
| DXHK048 | 6.7  | 72.2  |
| DXHK060 | 8.0  | 86.2  |
| DXHK070 | 9.1  | 98.4  |

### Minimum Room Area ( $A_{min}$ ) Adjustments

Use equation below to adjust the minimum room area, as applicable, based on the unit's installation height, altitude, and occupancy level it serves.

$$A_{min,adj} = \text{Nameplate } A_{min} \times \text{Altitude Adj} \times \text{Height Adj} \times F_{occ}$$

Multiply the altitude adjustment factor in the table below by  $A_{min}$  listed on the unit nameplate or in the Installation, Operation, and Maintenance (IOM) manual.

**Table 24. Altitude adjustment factor**

| Altitude (ft)        | Sea Level to 2000 | 2001 to 4000 | 4001 to 6000 | 6001 to 8000 | 8001 to 10000 | 10001 to 12000 | 12001 to 14000 | 14001 to 15000 | Over 15000 |
|----------------------|-------------------|--------------|--------------|--------------|---------------|----------------|----------------|----------------|------------|
| $A_{min}$ Adjustment | 1                 | 1.05         | 1.11         | 1.17         | 1.24          | 1.32           | 1.41           | 1.51           | 1.57       |

In addition,  $A_{min}$  can be adjusted if the unit is installed in a room at a height that is higher than the minimum height shown on the unit. To adjust  $A_{min}$ , multiply by the ratio of the unit minimum release height (in meters) / actual release height (in meters). Use 0.6 m in the ratio for unit minimum installation heights less than or equal to 0.6 m.

For institutional occupancies, ASHRAE Standard 15 applies an additional adjustment factor  $F_{occ}$  to the amount of a charge allowed in a space. To calculate the adjusted

$A_{min}$  for institutional occupancies, multiply the  $A_{min}$  on the nameplate by two.

#### EXAMPLE 1: 20 Ton Packaged Rooftop Multi-Zone VAV System Serving an Institutional Occupancy Space

The packaged unit serves 7600 ft<sup>2</sup> of a nursing home located at an altitude of 4000 ft. The unit has two equally charged 10 ton refrigeration circuits. Each circuit has 12 lbs of refrigerant with a minimum room area requirement of 180 ft<sup>2</sup> with a 2.2 m release height.



$$TA_{\text{min.adj}} = 180 \text{ ft}^2 \times 1.05 \times 2 = 378 \text{ ft}^2$$

No additional ventilation is required.

### EXAMPLE 2: 10 Ton Split System Serving a Single Commercial Occupancy Space

The split system serves a 1500 ft<sup>2</sup> manufacturing space at 5000 ft altitude. The final installed charge of the single circuit 10 ton unit is 20 lb. The unit has an open return with a release height of 1 m and ducted supply air. The unit  $A_{\text{min}}$  is 660 ft<sup>2</sup>.

$$A_{\text{min.adj}} = 660 \text{ ft}^2 \times 1.11 = 733 \text{ ft}^2$$

No additional ventilation is required.

### Determining Room Area (A or TA)

The room area (A) is the room area enclosed by the projection to the floor of the walls, partitions, and doors of the space that the equipment serves. For ducted systems, total room area (TA) of all rooms connected by ducts, may be used instead of A.

Rooms connected by drop ceilings only are not considered a single room.

Rooms on the same floor of the building, and connected by an open passageway, can be considered part of the same room if the passageway is a permanent opening, extends to the floor and is intended for people to walk through.

Adjacent rooms on the same floor of the building and connected by permanent openings in the walls and/or doors between rooms (including gaps between the wall and the floor), can be considered part of the same room if the openings meet the following criteria.

- The opening is permanent and cannot be closed.
- Openings extending to the floor, such as door gaps, need to be at least 20 mm above the floor covering surface.

- Natural ventilations opening areas must meet the requirements of ANSIASHRAE Standard 15-2022, Section 7.2.3.2.

Rooms that are connected by a mechanical ventilation system can be considered a single room area if the mechanical ventilation system meets the requirements of ANSIASHRAE Standard 15-2022, Section 7.6.4.

### Leak Detection System (Refrigerant charge greater than 3.91 lb per circuit)

The leak detection system consists of one or more refrigerant detection sensors. When the system detects a leak, the following mitigation actions will be initiated until refrigerant has not been detected for at least 5 minutes:

- Energize the supply fan(s) to deliver a required minimum amount of circulation airflow.
- Disable compressor operation.
- Provide an output signal that can be used to fully open zone dampers and/or VAV boxes and disable electric heat in VAV boxes.
- Provide an output signal that can be used to energize additional mechanical ventilation (if needed).
- Units without airflow proving will disable electric heat sources.

Building fire and smoke systems may override this function.

If the refrigerant sensor has a fault, is at the end of its life, or is disconnected, the unit will initiate the mitigation actions. Mitigation actions may be verified by disconnecting the sensor.

The refrigerant sensors do not need service. Use only manufacturer-approved sensors when replacement is required.



# Installation

## ⚠ WARNING

### Proper Field Wiring and Grounding Required!

Failure to follow code could result in death or serious injury.

All field wiring **MUST** be performed by qualified personnel. Improperly installed and grounded field wiring poses **FIRE** and **ELECTROCUTION** hazards. To avoid these hazards, you **MUST** follow requirements for field wiring installation and grounding as described in NEC and your local/state/national electrical codes.

## General Installation Checks

The checklist below is a summary of the steps required to successfully install a commercial unit. This checklist is intended to acquaint the installing personnel with what is required in the installation process. It does not replace the detailed instructions that are in the applicable sections of this manual.

1. Remove packaging and inspect the unit. Check the unit for shipping damage and material shortage; file a freight claim and notify appropriate sales representation.  
The EXH/V 0.75 to 6 tons and DXH/V 2 to 6 tons have been anchored to the skid with (4) angle brackets. Remove these brackets before lifting unit into place.
2. Verify the correct model, options and voltage from the unit nameplate.
3. Pull out all field attached parts (i.e. filter rack, duct collar, filter and mounting screws) from the unit packaging for field mounting.
4. Verify the installation location of the unit provides the required clearance for proper operation.
5. Remove refrigeration access panel and inspect the unit. Be certain the refrigerant tubing has clearance from adjacent parts.
6. Fabricate and install duct work
7. Install and connect a condensate drain line and trap to the drain connection.

## Main Electrical

### ⚠ WARNING

#### Hazardous Voltage!

Failure to disconnect power before servicing could result in death or serious injury.

Disconnect all electric power, including remote disconnects before servicing. Follow proper lockout/tagout procedures to ensure the power can not be inadvertently energized. Verify that no power is present with a voltmeter.

1. Verify the power supply complies with the unit nameplate specifications.
2. Inspect all control panel components; tighten any loose connections.
3. Connect properly sized and protected power supply wiring to a field-supplied/installed disconnect switch and to the main compressor contactor/power block 1K1 for DXH/V 2 to 6 tons and EXH/V 0.75 to 6 ton units.
4. Install proper grounding wires to an earth ground.

**Note:** All field-installed wiring must comply with NEC and applicable local codes.

## Electric Heat Requirements

1. Verify that the power supply complies with the electric heater specifications on the unit and heater nameplate.
2. Inspect the heater junction box and control panel; tighten any loose connections.
3. Check electric heat circuits for continuity.

## Low Voltage Wiring (AC) Requirements

1. Install the zone sensor or thermostat.
2. Connect properly sized control wiring to the proper termination points between the zone thermostat or sensor and the unit control panel.

## Filter Installation

Each unit ships with 1 in. (25.4 mm) standard, 2 in. (50.8 mm) standard, 2 in. MERV 8 or 2 in. MERV 13 filter. The quantity of filters is determined by unit size. The EXH and DXH units require field installation of the 1 in. or 2 in. filters rack. All sheet metal bracket, filter and hardware are in a box located on the side of the unit within the unit packaging. All vertical units ship with the filter rack and filters factory installed.

**Note:** Do not operate the unit without filters.

## Supply-Air Ductwork

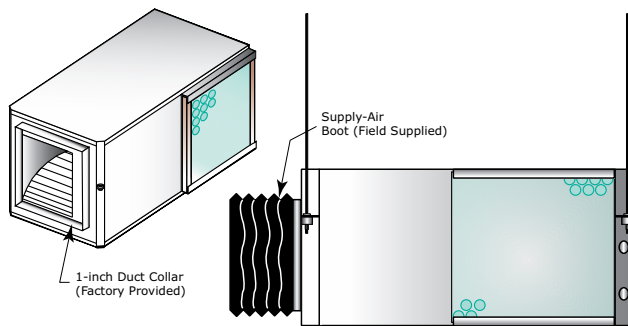
Horizontal DXH and EXH units require duct flanges to be field installed. The duct flange ships in a box on the side of the unit. Install the flange with (8) 3/8 in. (213 mm) factory supplied screws.

Install the 1 in. (25.4 mm) supply-air duct flange to the vertical and horizontal equipment with the (8) 5/16 in. (7.94 mm) factory-supplied head screws. The duct collar assembly for each unit is shipped with the unit in the same box where the IOM manual is located.

When attaching the field ductwork to the unit, provide a watertight flexible connector at the unit to prevent operating sounds from transmitting through the ductwork (See the figure below).

Elbows with turning vanes or splitters are recommended to minimize air noise due to turbulence and to reduce static pressure.

**Figure 16. Flexible supply-air connector (field provided)**



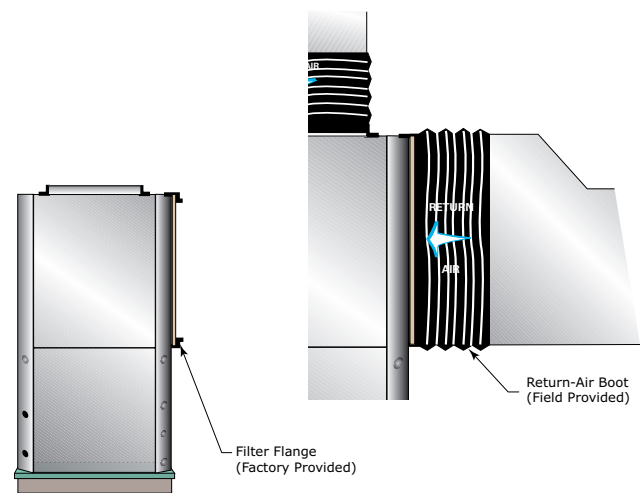
## Return-Air Ductwork

Install the 1/2 in. (25.4 mm/50.8 mm) adjustable filter rack to the horizontal equipment only with the use of (4) 5/16 in. (7.94 mm) factory supplied head screws. The vertical equipment factory ships with the filter rack and filter(s) installed.

When attaching the field ductwork to the unit, provide a watertight flexible connector at the unit to prevent operating sounds from transmitting through the ductwork.

Elbows with turning vanes or splitters are recommended to minimize air noise due to turbulence and to reduce static pressure.

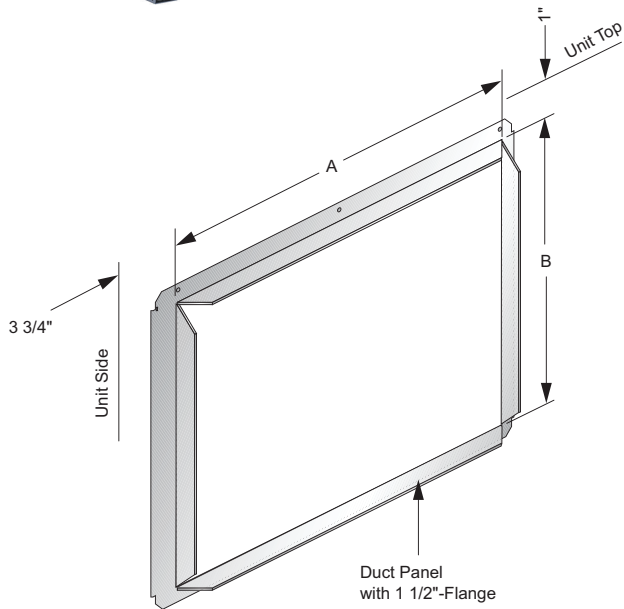
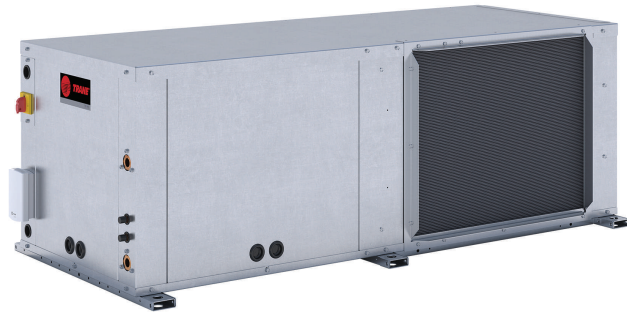
**Figure 17. Flexible return-air connector (field provided)**



## Ducted Panel

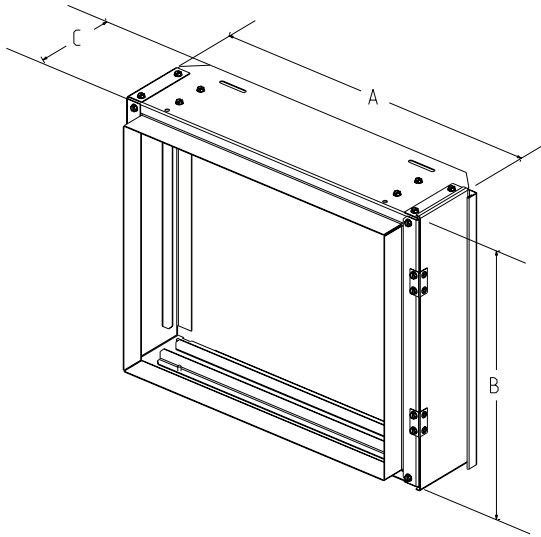
The return-air arrangement may be easily converted from a free return-air system, to a ducted return-air system with the addition of a return-air side panel. By replacing the filter racks with the return-air panel, a complete seal from the duct to the unit is possible. The 1.5 duct flange facilitates ease of field connection to the duct system. This accessory is typically used when the return-air filter is placed in a built-in ceiling grille, or placed within a field provided filter rack assembly.

Install the return-air duct panel to the return-air opening with the six screws provided for the filter rack assembly.

**Figure 18. Return-air duct panel**

**Table 25. Ducted panel - return air**

| Unit Size                | A (in.) | B (in.) | Duct Collar Part Number |
|--------------------------|---------|---------|-------------------------|
| EXVK009-012              | 18.50   | 16.50   | WSHPPND00002            |
| EXVK015                  | 20.00   | 17.50   | WSHPPND00003            |
| EXVK018-024, DXVK024     | 23.00   | 18.50   | WSHPPND00004            |
| EXVK030-036, DXVK036     | 29.50   | 20.50   | WSHPPND00005            |
| EXVK042-048, DXVK048     | 29.50   | 27.25   | WSHPPND00006            |
| EXVK060-070, DXVK060-070 | 29.50   | 33.25   | WSHPPND00007            |
| EXHK009-012              | 18.50   | 16.50   | WSHPPND00011            |
| EXHK015                  | 20.00   | 17.50   | WSHPPND00012            |
| EXHK018-024, DXHK024     | 23.00   | 18.50   | WSHPPND00013            |
| EXHK030-036, DXHK036     | 29.50   | 20.50   | WSHPPND00014            |
| EXHK042-048, DXHK048     | 38.88   | 19.75   | WSHPPND00015            |
| EXHK060-070, DXHK060-070 | 47.88   | 19.75   | WSHPPND00016            |

## Ducted Filter Rack



When filter access is needed at the unit in a ducted return, a ducted filter rack is available. Vertical unit filter racks are available in right or left access configurations. Horizontal units are available in top, bottom or side access configurations.

**Table 26. Ducted filter opening size - 0.75 to 6 tons**

| Unit Size                  | A (in.) | B (in.) | C (in.) |
|----------------------------|---------|---------|---------|
| EXHK 009-012               | 19.00   | 16.25   | 6.6     |
| EXHK 015                   | 20.50   | 17.25   | 6.6     |
| EXHK 018-024, DXHK 024     | 23.50   | 18.25   | 6.6     |
| EXHK 030-036, DXHK 036     | 30.00   | 20.25   | 6.6     |
| EXHK 042-048, DXHK 048     | 40.50   | 21.00   | 6.6     |
| EXHK 060-070, DXHK 060-070 | 50.50   | 21.00   | 6.6     |
| EXVK 009-012               | 19.00   | 16.25   | 6.6     |
| EXVK 015                   | 20.50   | 17.25   | 6.6     |
| EXVK 018-024, DXVK 024     | 23.50   | 18.25   | 6.6     |
| EXVK 030-036, DXVK 036     | 30.00   | 20.25   | 6.6     |
| EXVK 042-048, DXVK 048     | 30.00   | 27.00   | 6.6     |
| EXVK 060-070, DXVK 060-070 | 30.00   | 32.75   | 6.6     |

**Note:** All dimensions in inches. All dimensions are for accessory 2 or 4-inch filter rack.

## Sound Attenuation Pad

For sound-sensitive installations, a vibration pad (field provided) should be placed beneath the horizontal or vertical equipment. For the horizontal unit, the pad should be approximately twice the size of the unit foot print. For the vertical unit, the pad should be 0.5 in. (12.7 mm) thick and equal to the overall unit foot print.

## Hanging the Horizontal Unit

### ⚠ WARNING

#### Proper Structural Support Required!

Failure to ensure proper structural ceiling support could result in unit falling from its location which could result in death or serious injury.

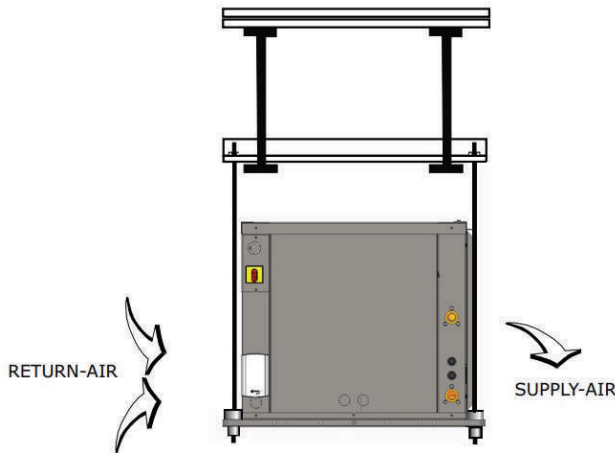
Ceiling structure must be strong enough to support the weight of the unit and any accessories. If unsure, check with a structural engineer.

1. Install the hanging isolators (located in the control box from factory) into the six hanging brackets.
2. Use a lift with a large supporting surface or a wooden structure supporting the base of the unit (hanging rails) when the unit is lifted for installation.
3. Secure the equipment to a joist, concrete, etc. with the use of 3/8 in. (9.7 mm) field provided (all-thread) rod. Each rod should contain field provided nuts and washers to complete the hanging installation.
4. All plumbing to the unit should conform per national and local codes and is the responsibility of the contractor. The 0.5 to 6 ton horizontals and EX/DXHK models do not need to be sloped. EXHK and DXHK 0.75 to 6 ton models must be installed level. The 0.5 to 5 ton horizontal models do not need to be sloped and must be installed level.

**Note:** Rods must be perpendicular to the mounting holes in the base rail of the horizontal unit.

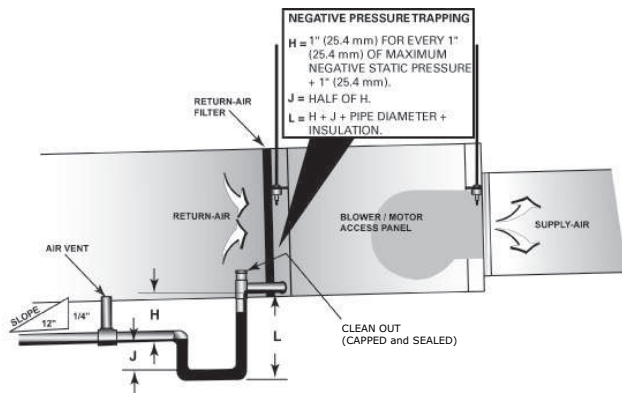
To hang the horizontal configuration (see the figure below):

Figure 19. Hanging the unit



## Condensate Drain Connection

Figure 20. Negative pressure system



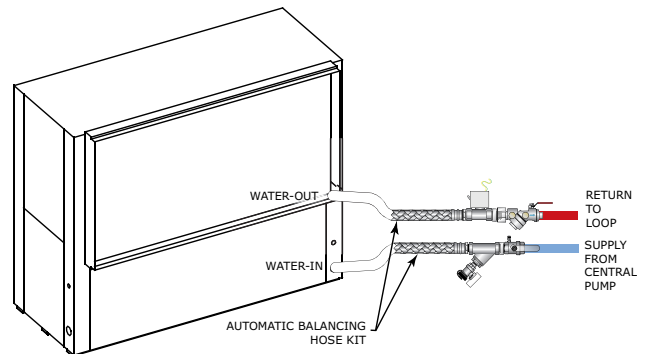
Install proper trapping to the equipment. The unit drain connection is 0.75 in. NPT for all DXH, DXV, and EXH/V 0.75 to 6 ton models.

When designing the condensate trap for the water-source system, it is important to consider the unit draw through design requiring negative pressure trapping.

In a properly trapped system, when condensate forms during normal operation, the water level in the trap rises until there is a constant flow. It is imperative to maintain water in the trap and not allow the trap to dry out during heating season. Keeping trap primed at all times will enable the water to flow properly. See the figure above for appropriate dimensions required in a negative pressure system.

## Supply Pipe Connections

Figure 21. Supply/return pipe connections



Connect the supply and return hoses to the water-inlet (from supply) and water-outlet (to return) of the unit. For vibration isolation, it is recommended that flexible steel-braided hoses be installed instead of hard piping the equipment to the main loop system. Figure above shows connection of a Hays Mesurflo® balancing hose kit to the water-in and water-out of a vertical unit.

**Note:** Above figure example incorporates the Hays Mesurflo® balancing hose kit and a 2-position isolation valve into the system design. An isolation valve is often used in variable speed pumping applications and is designed to stop water flow to the unit during non operation times. This allows the loop water pumps to run only when a requirement for pumping is needed for greater energy efficiency of the overall system design.

## Cleaning and Flushing the Water Loop

After the piping system is complete, the flexible hose connectors should be doubled back to complete the water circuit external to the unit (avoiding trash settle-out in the condenser). An extra pipe may be necessary to connect the hose kits.

1. Water circulation system should be filled with clean water using the water make up connections.

**Note:** Air vents should be open during filling.

2. With the air vents closed, start the circulating pump and then crack the air vents to bleed off the trapped air to confirm circulation through all components of the system.

**Note:** Make up water must be available to the system to replace the volume formerly occupied by the air that is bled off.

3. With the air vented and the water circulating, the entire system should be checked for leaks and repaired as required.
4. Operate the supplementary heat system (boiler) making checks per manufacturer's instructions. During this operation, visual checks should be made for leaks

that may have occurred due to increased heat. Repair as required.

5. Open the system at the lowest point for the initial blow down (making sure the make up water is equal to the water being dumped). Continue blow down until the water leaving the drain runs clear, but not less than 2 hours.
6. Shut down pumps and supplementary heat system. Reconnect the hoses placing the water-to-refrigerant heat exchanger in the water circulating system.

**Note:** Vents should be open when the pumps and supplementary heat system are shut down.

## Field Installed Power Wiring

### ⚠ WARNING

#### Proper Field Wiring and Grounding Required!

Failure to follow code could result in death or serious injury.

All field wiring **MUST** be performed by qualified personnel. Improperly installed and grounded field wiring poses **FIRE** and **ELECTROCUTION** hazards. To avoid these hazards, you **MUST** follow requirements for field wiring installation and grounding as described in NEC and your local/state/national electrical codes.

### NOTICE

#### Use Copper Conductors Only!

Failure to use copper conductors could result in equipment damage as the equipment was not designed or qualified to accept other types of conductors.

Verify that the power supply available is compatible with the unit's nameplate. Use only copper conductors to connect the power supply to the unit.

## Main Unit Power Wiring

### ⚠ WARNING

#### Proper Field Wiring and Grounding Required!

Failure to follow code could result in death or serious injury.

All field wiring **MUST** be performed by qualified personnel. Improperly installed and grounded field wiring poses **FIRE** and **ELECTROCUTION** hazards. To avoid these hazards, you **MUST** follow requirements for field wiring installation and grounding as described in NEC and your local/state/national electrical codes.

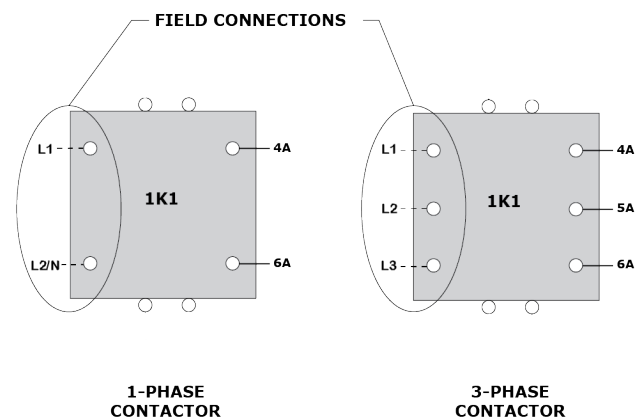
A field supplied disconnect switch must be installed at or near the unit in accordance with the National Electric Code (NEC latest edition).

Location of the applicable electric service entrance for HIGH (line voltage) may be found in the Dimensions section of this manual.

The high-voltage connection is made at the 1K1 contactor or 1TB power block inside the unit control box (See the figure below). Refer to the customer connection diagram that is shipped with the unit for specific termination points.

Provide proper grounding for the unit in accordance with the local and national codes.

Figure 22. Power wiring example



## Control Power Transformer

The 24 V control power transformers are to be used only with the accessories called out in this manual. A 50 VA transformer is externally fused. Transformers rated greater than 50 VA are equipped with circuit breakers. If a circuit breaker trips, turn OFF all power to the unit before attempting to reset it.

### ⚠ WARNING

#### Hazardous Voltage!

Failure to disconnect power before servicing could result in death or serious injury.

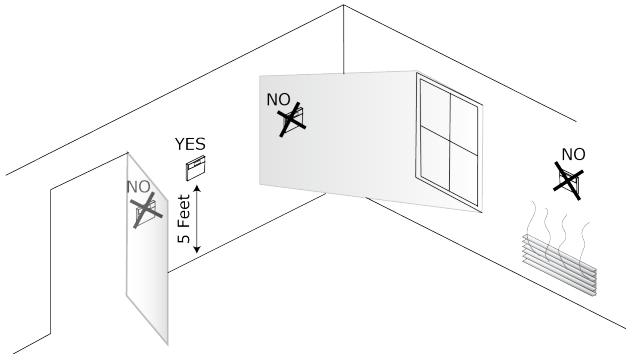
Disconnect all electric power, including remote disconnects before servicing. Follow proper lockout/tagout procedures to ensure the power can not be inadvertently energized. Verify that no power is present with a voltmeter.

The transformer is located in the control panel.



## Thermostat Location

Figure 23. Thermostat/sensor location



Location of the thermostat or zone sensor is an important element of effective room control.

Areas where the thermostat or zone sensor should not be located include:

- Behind doors or corners
- Near hot or cold air ducts
- Near radiant heat (heat emitted from appliances or the sun)
- Near concealed pipes or chimneys
- On outside walls or other non conditioned surfaces
- In airflows from adjacent zones or other units



## Thermostats and Zone Sensors

Table 27. Thermostat selection for use with the Deluxe controller





| Thermostat | Part Number  | Description  |
|------------|--------------|--|
|            | X13511535010 | 1 Heat/1 Cool, non-programmable commercial thermostat for conventional air conditioners and heat pumps that are configured without auxiliary heat<br><ul style="list-style-type: none"> <li>• 1 H/1 C</li> </ul>   |
|            | X13511536010 | 3 Heat/2 Cool, non-programmable commercial thermostat for conventional air conditioners and heat pumps that are configured with or without auxiliary heat.<br><ul style="list-style-type: none"> <li>• 3 H/2 C</li> </ul>  |
|            | X13511537010 | 3 Heat/2 Cool, programmable commercial thermostat for conventional (rooftop) air conditioners and heat pumps that are configured with or without auxiliary heat.<br><ul style="list-style-type: none"> <li>• 3 H/2 C</li> </ul>  |
|            | X13511538010 | 3Heat/2 Cool, programmable touch screen thermostat for conventional air conditioners and heat pump systems.<br>The thermostat will provide the human interface, zone temperature sensing both local and optional remote temperature sensing, and set point scheduling on a daily/weekly basis.<br>This thermostat can also display humidity with a control signal for dehumidification with a local humidity sensor or optional remote humidity sensor.<br><ul style="list-style-type: none"> <li>• 3 H/2 C</li> </ul> |






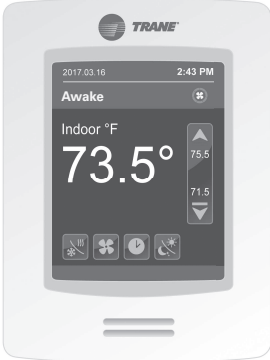
**Table 27. Thermostat selection for use with the Deluxe controller (continued)**

| Thermostat  | Part Number             | Description   |
|---|-------------------------|---|
|  | Pivot — BAYSTAT814A-W.  | Pivot Smart Thermostat is a Wi-Fi/ethernet thermostat for commercial applications. It has a very simple interface for occupants to adjust the thermostat. Cooling and heating control of multiple systems is made even easier and faster when connected to the Pivot App. Supports 2 stage heat pump with auxiliary heat. |
|  | XL824 - TCONT824AS52DB. | The XL824 Smart thermostat is a Wi-Fi/ethernet thermostat for Residential applications such as single family homes, condominiums and apartments. Supports 2 stage heat pump with auxiliary heat. The XL824 can be connected to the Nexia Home App and other home automation systems.                                      |




**Table 28. Zone sensor selection for use with Symbio™ 400-B controller**

| Sensor  | Part Number  | Description   |
|---|--------------|---|
|   | X13790886010 | Wired temperature sensor with an LCD display <ul style="list-style-type: none"> <li>Allows an occupant to control the temperature setpoint, request timed override of system operation, and provides a COMM module to service technicians. Symbio 400-B Compatible</li> </ul> |
|  | X13651467020 | Communication Module <ul style="list-style-type: none"> <li>Sold in packs of 12</li> <li>Provides local RJ22 connection to Trane® service tools for easy, low cost maintenance.</li> </ul>  |
|  | X13511529010 | Zone Sensor <ul style="list-style-type: none"> <li>Symbio 400-B compatible</li> <li>External setpoint adjustment wheel</li> </ul>   |
|  | X13511527010 | Zone Sensor <ul style="list-style-type: none"> <li>Symbio 400-B compatible</li> <li>External setpoint adjustment wheel</li> <li>ON and CANCEL buttons</li> </ul>  |

**Table 28. Zone sensor selection for use with Symbio™ 400-B controller (continued)**

| Sensor  | Part Number  | Description  |
|---|--------------|--|
|    | X1379084501  | Zone Sensor <ul style="list-style-type: none"> <li>• Symbio 400-B compatible</li> <li>• External setpoint adjustment wheel</li> <li>• ON and CANCEL buttons</li> <li>• Fan switch AUTO-OFF</li> </ul>  |
|    | X1379044401  | Temperature and relative humidity sensor <ul style="list-style-type: none"> <li>• Symbio 400-B compatible</li> </ul>   |
|   | X13790993001 | Commercial Touch Screen Programmable Zone Sensor <ul style="list-style-type: none"> <li>• Supports Standby, Occupied, and Unoccupied</li> <li>• 7 day, 5+2 day, and 5+1+1 day</li> <li>• Cannot be used with BAS as sensor ties up BACnet link. For use with factory-programmed Symbio 400-B.</li> </ul> <p><b>Notes:</b></p> <ul style="list-style-type: none"> <li>• <i>Adjusting the rotary switch on Symbio 400-B may be required to correspond address configuration in the sensor. See the installation manual for more information.</i></li> <li>• <i>Additional configuration is needed in the field to use the Programmable zone sensors (to put BAS points in service on Symbio 400-B).</i></li> </ul> |
|  | X13790992001 | Residential Touch Screen Programmable Zone Sensor <ul style="list-style-type: none"> <li>• Supports Awake, Away, Home, and Sleep</li> <li>• 7 day, 5+2 day, and 5+1+1 day</li> <li>• Cannot be used with BAS as sensor ties up BACnet link. For use with factory-programmed Symbio 400-B.</li> </ul> <p><b>Notes:</b></p> <ul style="list-style-type: none"> <li>• <i>Adjusting the rotary switch on Symbio 400-B may be required to correspond address configuration in the sensor. See the installation manual for more information.</i></li> <li>• <i>Additional configuration is needed in the field to use the Programmable zone sensors (to put BAS points in service on Symbio 400-B).</i></li> </ul>     |

**Table 29. Wireless zone sensor selection for use with Symbio™ 400-B controller**

| Sensor  | Part Number  | Description   |
|---|--------------|---|
|  | X13790955010 | Trane Air-Fi® WCS-SD (display) <ul style="list-style-type: none"> <li>• Symbio 400-B Compatible</li> <li>• Easy-to-use interface for clear and simple monitoring and control</li> </ul>   |
|  | X13790956010 | Trane Air-Fi WCS-SB (base) <ul style="list-style-type: none"> <li>• Symbio 400-B Compatible</li> <li>• Simplicity</li> <li>• Eliminates local temperature control when higher control level is required.</li> </ul>                     |
|  | X13790973030 | Wireless communications sensor accessory—2% relative humidity (RH) sensor module (WCS-SH)<br>The optional RH sensor module plugs in to any WCS model, further simplifying installation by eliminating the needed for additional wiring. |

## Controls Using 24 Vac

Before installing any wire, refer to the electrical access locations in the Unit Dimensions and Weights sections of this manual.

The AC control wiring between the controls and the unit termination point must not exceed 3 Ohms/conductor for the length of the run.

### NOTICE

#### Component Failure!

Resistance in excess of 3 ohms per conductor could result in component failure due to insufficient AC voltage supply.

Do not exceed three (3) ohms per conductor for the length of the run.

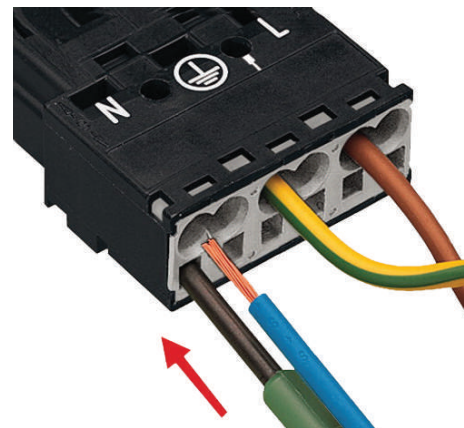
Check all loads and conductors for grounds, shorts, and mis-wiring. Use copper conductors unless otherwise specified. Do not run the AC low-voltage wiring in the same conduit with the high voltage power wiring.

**Table 30. 24V AC conductors**

| Distance from unit to control | Recommended wire size |
|-------------------------------|-----------------------|
| 000-460 ft                    | 18 gauge              |
| 461-732 ft                    | 16 gauge              |
| 733-1000 ft                   | 14 gauge              |

Low-voltage connection diagrams for deluxe 24 V control packages for these thermostats mounted on 0.75 to 6 ton equipment sizes are shown in the figures below.

**Figure 24. Low voltage wire connection**



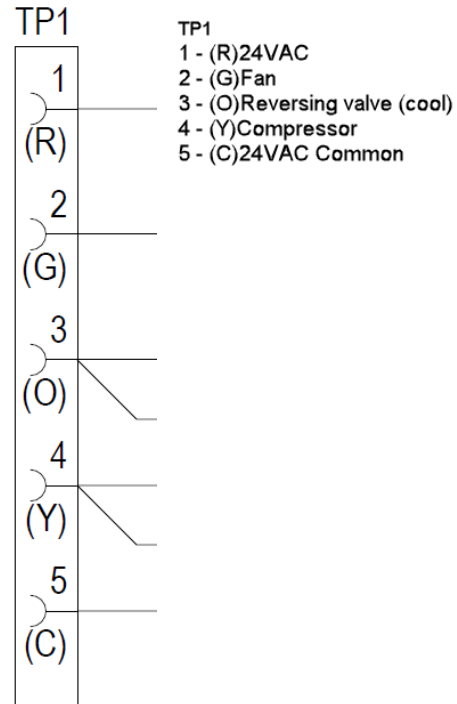
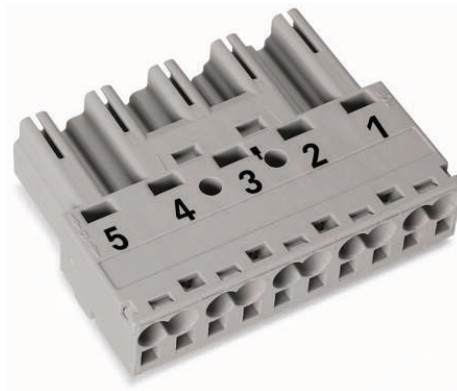
**Figure 25. Low voltage single wire connection**


Make connection for a single-wire by inserting a single wire after stripping off the coating.

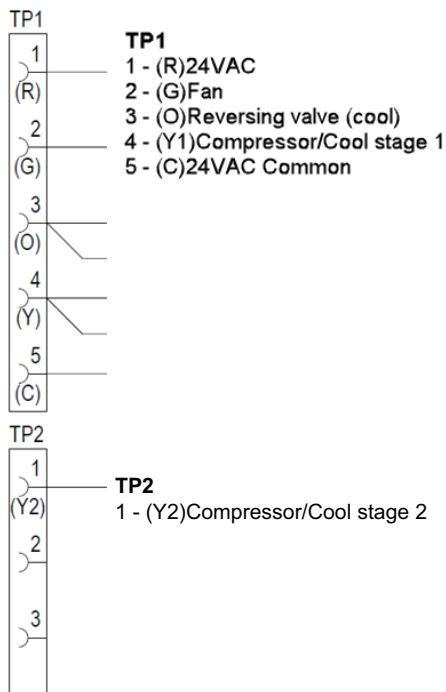
**Figure 26. Low voltage stranded wire connection**


Follow the steps to connect the stranded wire:

1. Release the spring with a dedicated screwdriver (blade width 2.5 mm)
2. Insert the stripped cable as far as it gets inserted.
3. Complete the connection by removing the screwdriver.

**Figure 27. Deluxe controls**

**Figure 28. TP1 connection type**


**Figure 29. Deluxe controls with WSE or DX two-stage**



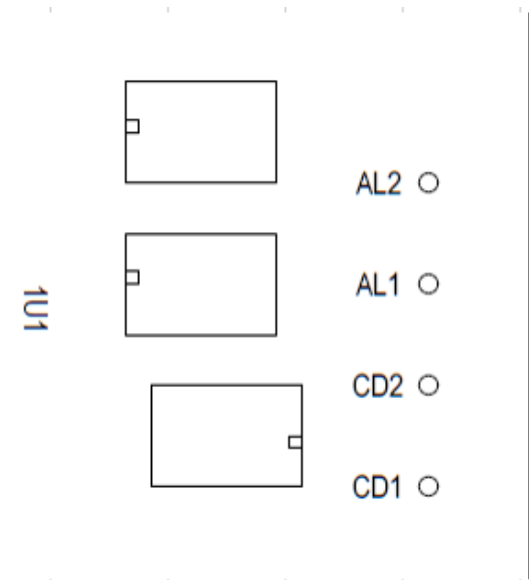
**Figure 30. TP2 connection type**



**Figure 31. Deluxe controls humidistat connections between wires H1 and H2 in control box**



**Figure 32. Deluxe controls general alarm and compressor disable**



Deluxe board (1U1) connections

AL1, AL2 - Alarm Contact output

CD1, CD2 - Compressor Disable input (24Vac)

For installation, operation and programming see Symbio™ 400-B/500 Programmable Controllers Water Source Heat Pump (WSHP) Installation, Operation, and Maintenance guide (BAS-SVX092\*-EN)..

**⚠ WARNING**

**Hazardous Voltage!**  
Failure to disconnect power before servicing could result in death or serious injury. Disconnect all electric power, including remote disconnects before servicing. Follow proper lockout/tagout procedures to ensure the power can not be inadvertently energized. Verify that no power is present with a voltmeter.

**⚠ WARNING**

**Proper Field Wiring and Grounding Required!**  
Failure to follow code could result in death or serious injury. All field wiring **MUST** be performed by qualified personnel. Improperly installed and grounded field wiring poses **FIRE** and **ELECTROCUTION** hazards. To avoid these hazards, you **MUST** follow requirements for field wiring installation and grounding as described in NEC and your local/state/national electrical codes.

## External Smoke Detection Wiring to Unit

### Deluxe Controller

To inhibit operation of the compressor and fan for a safety shutdown, it is necessary to break the wire (21X) from the 24 Volt transformer to the 1TB1 terminal block. This can be done with the dry contacts of a relay. When that connection is opened, it terminates voltage to both the deluxe controller and the thermostat, which stops/prevents all control function to the fan and compressor.

### Symbio™ 400-B Controller

To inhibit operation of the compressor and fan for a safety shutdown, it is necessary to break the wire (21A) from the 24 Volt transformer to the Symbio 400-B (1U1). This can be done with the dry contacts of a relay. When that connection is opened, it terminates the power voltage to the controller, which stops/prevents all control function including the fan and compressor.

## Airflow Adjustment

### ⚠ WARNING

#### Rotating Components!

Failure to disconnect power before servicing could result in rotating components cutting and slashing technician which could result in death or serious injury.

During installation, testing, servicing and troubleshooting of this product it may be necessary to work with live and exposed rotating components. Have a qualified or licensed service individual who has been properly trained in handling exposed rotating components, perform these tasks.

### Units with Deluxe 24V controls

The ECM is programmed for constant torque and delivers airflow similar to a PSC motor while operating at a higher efficiency.

Figure 33. ECM control box

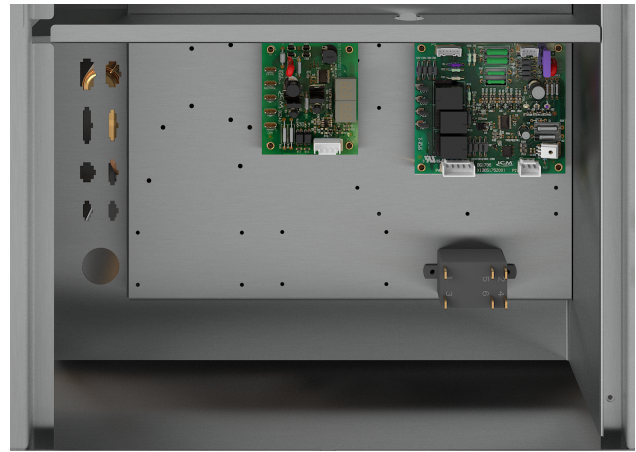


Figure 34. ECM control board



1. Potentiometer will be used to adjust the PWM output
2. Seven segment display

Using a screwdriver, the potentiometer is used to adjust the PWM output from 20% to 100% PWM. Increasing the PWM increases the motor speed. When setting the airflow for air balancing, the high-speed terminal (GH) must have 24 Vac signal. This confirms the PWM output is adjusted for the full load airflow.

The display shows the commanded motor speed percentage. If running on low speed (GL), the low-speed value is displayed. If running in GH the high-speed value is displayed. If both GH and GL input signals are present, the PWM output value is the GH value.

**Note:** ECM control board is only on units with Deluxe 24V controls. Tracer® TU is used to adjust fan speed on units with Symbio™ 400-B controls.



## Waterside Economizer Installation

### ⚠ WARNING

#### Hazardous Voltage!

Failure to disconnect power before servicing could result in death or serious injury.

Disconnect all electric power, including remote disconnects before servicing. Follow proper lockout/tagout procedures to ensure the power can not be inadvertently energized. Verify that no power is present with a voltmeter.

### ⚠ WARNING

#### Proper Field Wiring and Grounding Required!

Failure to follow code could result in death or serious injury.

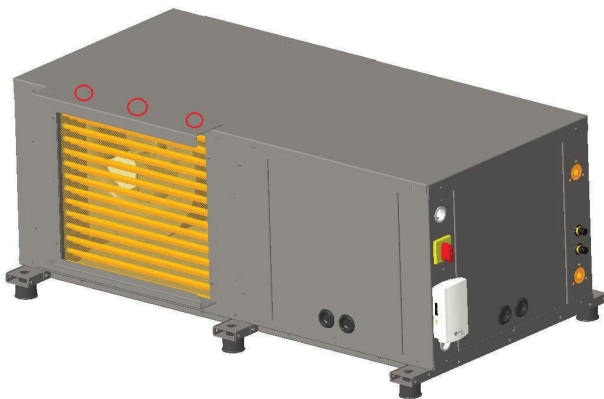
All field wiring **MUST** be performed by qualified personnel. Improperly installed and grounded field wiring poses **FIRE** and **ELECTROCUTION** hazards. To avoid these hazards, you **MUST** follow requirements for field wiring installation and grounding as described in NEC and your local/state/national electrical codes.

## Waterside Economizer Installation for Horizontal 0.75 to 6 Ton Units

The following steps were sequenced to aid in the installation and pairing of a water side economizer to a 0.75 to 6 ton horizontal water source heat pump.

1. Remove the filter bracket from the unit. It is secured by four screws: three on top (circled) and two on the bottom (not shown). Do not discard the filter brackets.

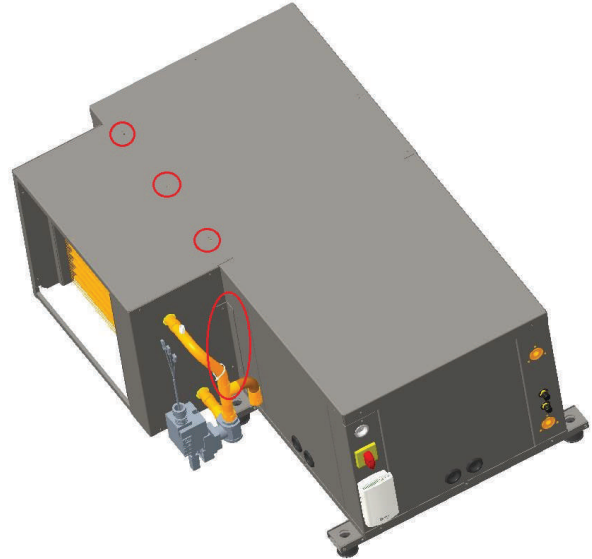
Figure 35. Step 1



2. Mount the waterside economizer to the unit. It is secured to the unit using the three engagement holes used for the filter bracket on the top. Secure the sides of the economizer using the two L-Brackets on each side by lining up the engagement holes for the

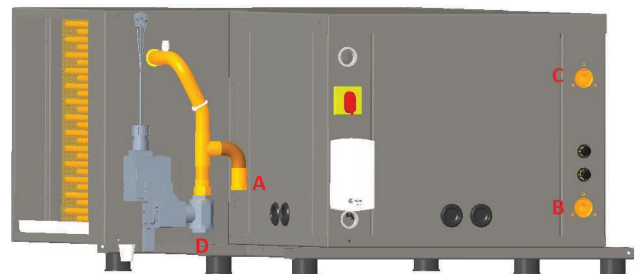
fasteners (total of four for each bracket). The engagement hole locations and L-Bracket can be seen in the Figure 36, p. 47 .

Figure 36. Step 2



3. Attach the filter bracket to the waterside economizer using the five screws removed earlier. Install the air filter.
4. Install the braided hose connecting point A (leaving the WSE) to point B (entering the WSHP). Connect the supply water to point D and the return water to point C.

Figure 37. Step 4



5. Locate the entering water sensor that is located behind the unit's control box, and wire tie it to the water SUPPLY side of the piping. The sensor must be mounted before the two-position valve. Attaching the sensor anywhere else will cause the WSE to not operate correctly. Bundle up any excess sensor wire and wire tie the bundle neatly.
6. Locate the WSE valve wires (35B (COM), 36B (OPEN), 37B (CLOSE)) behind control box, and connect to the valve actuator. Bundle up any excess wire and wire tie the bundle neatly. Direction of rotation is reversible with switch.
7. Insulate the economizing piping package and the associated hoses via field pipe insulation. Insulating the

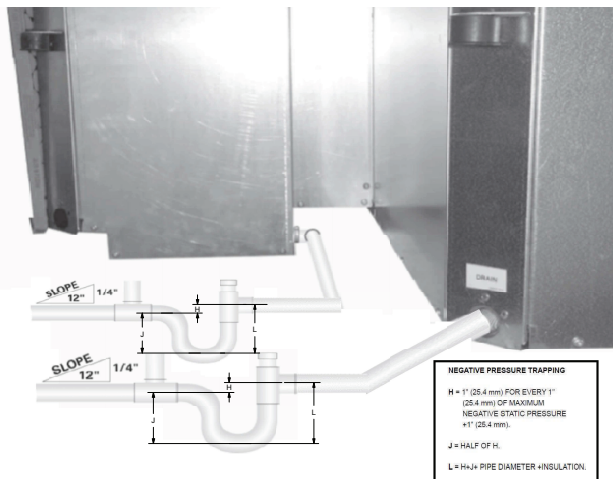
piping will prevent condensation from forming on the pipe and dripping on the floor.

**Notes:**

- *Trane does not provide insulation on the economizing piping package. The insulation must be field provided and field installed.*
- *Trane does not provide condensate overflow protection of the waterside economizer. This must be field provided and installed.*

8. Field pipe the drain lines of the waterside economizer and water-source heat pump. Both the WSE and unit condensate drains must be separately trapped for proper handling of condensation (see [Figure 38, p. 48](#) ). Both Vertical and Horizontal units will be piped similar to each other. The drain connection is located on the bottom side of the economizing coil.

**Figure 38. Step 8**



**Table 31. Economizer part numbers**

| Supply-Air Arrangement | Unit                     | Part Number  |
|------------------------|--------------------------|--------------|
| Left Supply            | EXVK009-012              | WSHPECN00016 |
|                        | EXVK015                  | WSHPECN00017 |
|                        | EXVK018-024, DXVK024     | WSHPECN00018 |
|                        | EXVK030-036, DXVK036     | WSHPECN00019 |
|                        | EXVK042-048, DXVK048     | WSHPECN00020 |
|                        | EXVK060-070, DXVK060-070 | WSHPECN00021 |
| Right Supply           | EXVK009-012              | WSHPECN00023 |
|                        | EXVK015                  | WSHPECN00024 |
|                        | EXVK018-024, DXVK024     | WSHPECN00025 |
|                        | EXVK030-036, DXVK036     | WSHPECN00026 |
|                        | EXVK042-048, DXVK048     | WSHPECN00027 |
|                        | EXVK060-070, DXVK060-070 | WSHPECN00028 |

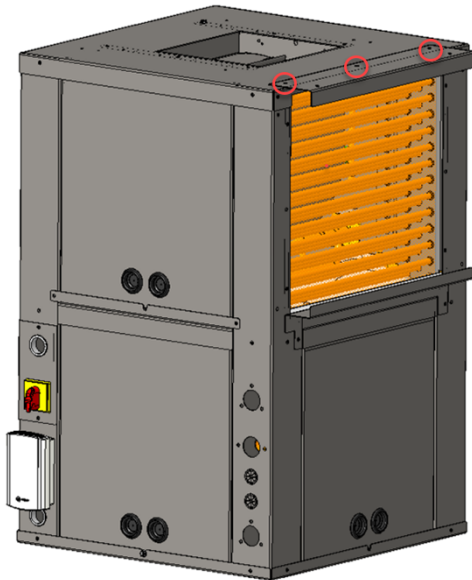
**Waterside Economizer Installation for Vertical Units**

The following steps were sequenced to aid in the installation and pairing of a water side economizer to a EXV and DXV water source heat pump.

1. Remove the filter bracket from the unit. It is secured by five screws: three on top (circled) and two on the bottom (not shown). Do not discard the filter brackets.

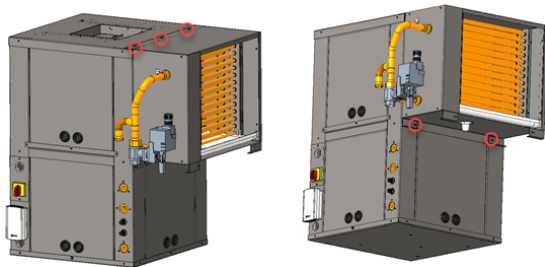


**Figure 39. Step 1**



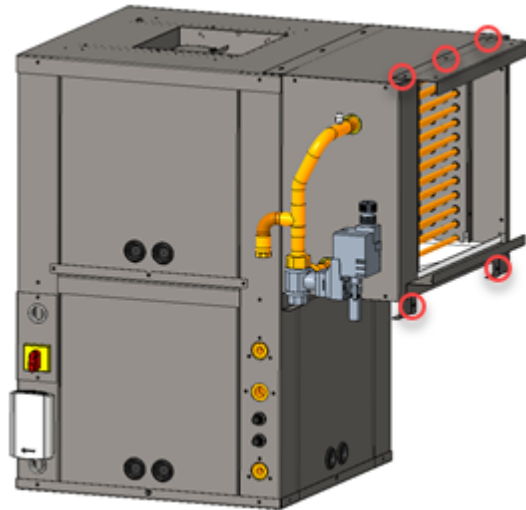
2. Mount the waterside economizer to the unit. It is secured to the unit using the five engagement holes that were used for the filter brackets: three on top and two on the bottom.

**Figure 40. Step 2**



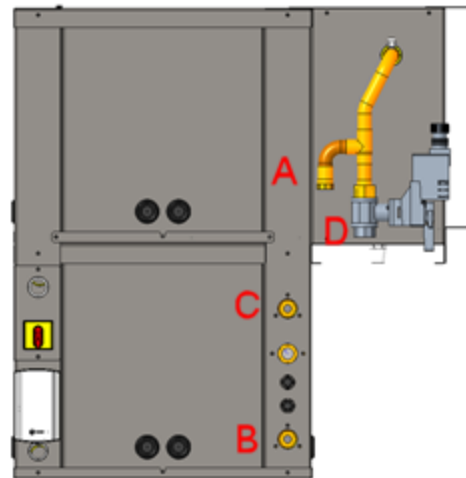
3. Attach the filter brackets to the waterside economizer using five screws. Install the air filter.

**Figure 41. Step 3**



4. Install the braided hose connecting point A (leaving the WSE) to point B (entering the WSHP). Connect the supply water to point D and the return water to point C.

**Figure 42. Step 4**



5. Locate the entering water sensor that is located behind the unit's control box, and wire tie it to the water SUPPLY side of the piping. The sensor must be mounted before the two-position valve. Attaching the sensor anywhere else will cause the WSE to not operate correctly. Bundle up any excess sensor wire and wire tie the bundle neatly.
6. Locate the WSE valve wires (35B (COM), 36B (OPEN), 37B (CLOSE)) behind control box, and connect to the valve actuator. Bundle up any excess wire and wire tie the bundle neatly. Direction of rotation is reversible with switch.
7. Insulate the economizing piping package and the associated hoses via field pipe insulation. Insulating the

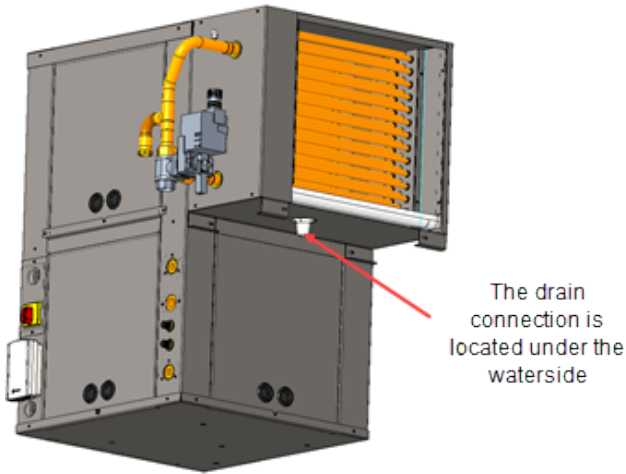
pipng will prevent condensation from forming on the pipe and dripping on the floor.

**Notes:**

- *Trane does not provide insulation on the economizing piping package. This insulation must be field provided and field installed.*
- *Trane does not provide condensate overflow protection of the waterside economizer. This must be field provided and installed.*

8. Field pipe the drain lines of the waterside economizer and water-source heat pump together prior to installing a condensate trap for proper trapping of condensation (see [Figure 38, p. 48](#)). The vertical units will be piped similar to the horizontal units.

**Figure 43. Step 8**



**Table 32. Economizer part numbers**

| Supply-Air Arrangement | Unit                     | Part Number  |
|------------------------|--------------------------|--------------|
| Left Supply            | EXVK009-012              | WSHPECN00002 |
|                        | EXVK015                  | WSHPECN00003 |
|                        | EXVK018-024, DXVK024     | WSHPECN00004 |
|                        | EXVK030-036, DXVK036     | WSHPECN00005 |
|                        | EXVK042-048, DXVK048     | WSHPECN00006 |
|                        | EXVK060-070, DXVK060-070 | WSHPECN00007 |
| Right Supply           | EXVK009-012              | WSHPECN00009 |
|                        | EXVK015                  | WSHPECN00010 |
|                        | EXVK018-024, DXVK024     | WSHPECN00011 |
|                        | EXVK030-036, DXVK036     | WSHPECN00012 |
|                        | EXVK042-048, DXVK048     | WSHPECN00013 |
|                        | EXVK060-070, DXVK060-070 | WSHPECN00014 |



# Waterside Economizer Start-Up Sequence

1. Set the thermostat to the highest position.
  2. Set the thermostat system switch to COOL with the fan control to AUTO. The compressor should NOT run.
  3. Reduce the thermostat setting until the compressor, reversing valve, solenoid valve, and loop pump are energized. Adjust water flow utilizing pressure/temperature plugs and comparing to tables contained in specification sheet data. Water leaving the heat exchanger should be warmer than the entering water temperature (approximately 9 to 12°F); blower operation should be smooth; compressor and blower amps should be within data plate ratings; the suction line should be cool with no frost observed in the refrigerant circuit.
  4. Check the cooling refrigerant pressures against values in “.”.
- Note:** *If cooling mode is activated, and the entering water temperature of the heat pump falls below 55°F, the 2-position, water side economizing valve will become energized (open) and compressor operation will halt allowing for free cooling in the space.*
5. Turn the thermostat system switch to the OFF position. Unit should stop running and the reversing valve should de-energize.
  6. Leave unit off for approximately FIVE minutes to allow for pressure equalization.
  7. Turn the thermostat to the lowest setting.
  8. Set the thermostat system switch to the HEAT position.
  9. Adjust the temperature setting upward until the unit is energized. Warm air should blow from the register. A water temperature decrease of approximately 5 to 9°F leaving the heat exchanger should be noted. The blower and compressor operation should be smooth with no frost observed in the refrigeration circuit.
  10. Check the heating refrigerant pressures against values in “.”.
- Note:** *For units with boilerless electric heat option: In heating mode, if the entering water temperature of the heat pump falls below 45°F, the electric heater will be energized, and compressor operation will halt. Once the entering water temperature rises above 50°F, the boilerless controls returns the unit.*
11. Set the thermostat to maintain the desired space temperature.
  12. Instruct the owner on system operation.

**Table 33. Waterside economizing three-way valve specifications (DXHK/DXVK units)**

| Unit Size         | Valve Conn. Size | Valve Pres. Rating | Valve Close-off pressure | Valve Temp. Range              | Actuator   |
|-------------------|------------------|--------------------|--------------------------|--------------------------------|--|
| DXHK/DXVK 024     | 3/4 FPT          | 600 psi            | 200 psi                  | 0°F to 212°F<br>-18°C to 121°C | Non-spring return type<br>24 Vac +/- 20%<br>135 second stroke time<br>24 Cv at full port |
| DXHK/DXVK 036-070 | 1 FPT            | 600 psi            | 200 psi                  | 0°F to 212°F<br>-18°C to 121°C | Non-spring return type<br>24 Vac +/- 20%<br>135 second stroke time<br>30 Cv at full port |

**Note:** *The valve body is constructed from forged brass with nickel plating, with the ball and stem constructed of stainless steel. For other information pertaining to the economizing water valve, see the valve's data plate.*

**Table 34. Waterside economizing three-way valve specifications (EXHK/EXVK units)**

| Unit Size                 | Valve Conn. Size | Valve Pres. Rating | Valve Close-off pressure | Valve Temp. Range           | Actuator   |
|---------------------------|------------------|--------------------|--------------------------|-----------------------------|--|
| EXHK 009-015              | 1/2 FPT          | 600 psi            | 200 psi                  | 0°F to 250°F -18°C to 121°C | Non-spring return type<br>24 Vac +/- 20%<br>135 second stroke time<br>10 Cv at full port |
| EXHK 018-036 EXVK 009-024 | 3/4 FPT          | 600 psi            | 200 psi                  | 0°F to 250°F -18°C to 121°C | Non-spring return type<br>24 Vac +/- 20%<br>135 second stroke time<br>24 Cv at full port |



## Waterside Economizer Start-Up Sequence

**Table 34. Waterside economizing three-way valve specifications (EXHK/EXVK units) (continued)**

| Unit Size                    | Valve Conn. Size | Valve Pres. Rating | Valve Close-off pressure | Valve Temp. Range              | Actuator   |
|------------------------------|------------------|--------------------|--------------------------|--------------------------------|--|
| EXHK 042-070 EXVK<br>030-070 | 1 FPT            | 600 psi            | 200 psi                  | 0°F to 250°F -18°C to<br>121°C | Non-spring return type<br>24 Vac +/- 20%<br>135 second stroke time<br>30 Cv at full port |

*Note: The valve body is constructed from forged brass with nickel plating, with the ball and stem constructed of stainless steel. For other information pertaining to the economizing water valve, see the valve's data plate.*



## Pre-Start Checklist

Before energizing the unit, the following system devices must be checked:

- Is the high voltage power supply correct and in accordance with the nameplate ratings?
- Is phasing of the unit correct per compressor rotation (scroll compressor only)?
- Is the field wiring and circuit protection the correct size?
- Is the low voltage control circuit wiring correct per the unit wiring diagram?
- Is the piping system clean/complete and correct? (A recommendation of all system flushing of debris from the water-to-refrigerant heat exchanger, along with air purging from the water-to-refrigerant heat exchanger be done in accordance with the Closed-Loop/Ground Source Heat Pump Systems Installation Guide).
- Is vibration isolation provided? (i.e. unit isolation pad, hose kits)
- Is unit serviceable? (See clearance specifications in Unit Dimensions and Weights).
- Are the low/high-side pressure temperature caps secure and in place?
- Are all the unit access panels secure and in place?
- Is the thermostat in the OFF position?
- Is the water flow established and circulating through all the units?
- Is the duct work correctly sized, run, taped, insulated and weather proofed with proper unit arrangement?
- Is the condensate line properly sized, run, trapped, pitched and primed?
- Is the zone sensor correctly wired and in a good location?
- Does the indoor blower turn freely without rubbing?
- Has all work been done in accordance with applicable local and national codes?
- Has heat transfer fluid been added in the proper mix to prevent freezing in closed system application?



# Start-Up

## Initial Unit Start-Up

**Note:** Start-up with the heat pump thermostat is included below:

1. Set the thermostat to the highest position.
2. Set the thermostat system switch to COOL with the fan control to AUTO. The compressor should NOT run.
3. Reduce the thermostat setting until the compressor, reversing valve, solenoid valve, and loop pump are energized. Adjust water flow utilizing pressure/temperature plugs and comparing to tables contained in specification sheet data.
4. Water leaving the heat exchanger should be warmer than the entering water temperature (approximately 9-12°F); blower operation should be smooth; compressor and blower amps should be within data plate ratings; the suction line should be cool with no frost observed in the refrigerant circuit.
5. Check the cooling refrigerant pressures against values in “.”.
6. Turn the thermostat system switch to the OFF position. Unit should stop running and the reversing valve should de-energize.
7. Leave unit off for approximately FIVE minutes to allow for pressure equalization.
8. Turn the thermostat to the lowest setting.
9. Set the thermostat system switch to the HEAT position.
10. Adjust the temperature setting upward until the unit is energized. Warm air should blow from the register. A water temperature decrease of approximately 5-9°F leaving the heat exchanger should be noted. The blower and compressor operation should be smooth with no frost observed in the refrigeration circuit.
11. Check the heating refrigerant pressures against values in “.”.
12. Set the thermostat to maintain the desired space temperature.
13. Instruct the owner on system operation.

**Table 35. Checklist**

| MODE                         | Heat   | Cool   |
|------------------------------|--------|--------|
| Entering fluid temperature   | _____F | _____F |
| Leaving fluid temperature    | _____F | _____F |
| Temperature differential     | _____F | _____F |
| Return-air temperature DB/WB | _____F | _____F |

**Table 35. Checklist (continued)**

| MODE   | Heat      | Cool      |
|--|-----------|-----------|
| Supply-air temperature DB/WB                   | _____F    | _____F    |
| Temperature differential                       | _____F    | _____F    |
| Water coil heat exchanger (Water Pressure IN)  | _____PSIG | _____PSIG |
| Water coil heat exchanger (Water Pressure OUT) | _____PSIG | _____PSIG |
| Pressure Differential                          | _____PSIG | _____PSIG |
| COMPRESSOR                                     |           |           |
| Amps   |           |           |
| Volts  |           |           |
| Discharge line temperature (after 10 minutes)  | _____F    | _____F    |

## Start-Up Checklist and Log

Installing Contractor: Use this checklist to thoroughly check-out the system and units before and during start-up. (This form need not be returned to the factory unless requested during technical service support).

|                |  |
|----------------|--|
| Job Name:      |  |
| Model Number:  |  |
| Date:          |  |
| Serial Number: |  |

To minimize troubleshooting and costly system failures, complete the following checks and data entries before the system is put into full operation.

## Operating Pressures

There are many variables (airflow, air temperatures) in an air conditioning system that will affect operating refrigerant pressures and temperatures. The charts below shows approximate conditions and is based on air flow at the rated SCFM, entering air at 80.6°F (DB), 66.2°F (WB) in cooling, 68°F (DB) in heating. (+)Heating data with 35°F EWT is based on the use of an anti-freeze solution having a freezing point 20°F lower than the minimum expected entering temperature.

**Table 36. Operating pressures in cooling/heating for DX\* units**

| Operating Data |  |                  |                         |                           |                      |                       |                         |                           |                      |                       |
|----------------|--|------------------|-------------------------|---------------------------|----------------------|-----------------------|-------------------------|---------------------------|----------------------|-----------------------|
| Model          | Entering Water Temp Entering Water Temp (°F) | Water Flow (GPM) | Cooling                 |                           |                      |                       | Heating                 |                           |                      |                       |
|                |  |                  | Suction Pressure (psig) | Discharge Pressure (pgig) | Water Temp Rise (°F) | Air Temp Drop (°F DB) | Suction Pressure (psig) | Discharge Pressure (psig) | Water Temp Drop (°F) | Air Temp Rise (°F DB) |
| DXV/H024       | 32   | 4.80             | —                       | —                         | —                    | —                     | 66-80                   | 253-309                   | 6-7                  | 20-24                 |
| DXV/H024       | 32   | 6.00             | —                       | —                         | —                    | —                     | 67-82                   | 255-311                   | 5-6                  | 20-24                 |
| DXV/H024       | 45   | 4.80             | 102-124                 | 153-187                   | 12-14                | 24-29                 | 83-101                  | 277-338                   | 7-9                  | 25-30                 |
| DXV/H024       | 45   | 6.00             | 101-123                 | 147-180                   | 9-12                 | 24-29                 | 85-104                  | 279-341                   | 6-7                  | 26-31                 |
| DXV/H024       | 55   | 4.80             | 104-127                 | 180-220                   | 12-14                | 23-28                 | 99-120                  | 292-357                   | 8-10                 | 28-35                 |
| DXV/H024       | 55   | 6.00             | 104-127                 | 174-212                   | 9-11                 | 23-28                 | 102-124                 | 295-361                   | 7-8                  | 29-36                 |
| DXV/H024       | 68   | 4.80             | 106-130                 | 219-267                   | 11-14                | 22-27                 | 113-138                 | 318-389                   | 10-12                | 33-40                 |
| DXV/H024       | 68   | 6.00             | 106-130                 | 212-259                   | 9-11                 | 22-27                 | 117-143                 | 322-394                   | 8-10                 | 34-41                 |
| DXV/H024       | 75   | 4.80             | 110-135                 | 240-293                   | 11-14                | 22-27                 | 126-154                 | 330-404                   | 11-13                | 36-44                 |
| DXV/H024       | 75   | 6.00             | 110-135                 | 233-285                   | 9-11                 | 22-27                 | 130-159                 | 335-409                   | 9-11                 | 37-45                 |
| DXV/H024       | 86   | 4.80             | 113-138                 | 280-342                   | 12-14                | 22-27                 | 148-181                 | 349-427                   | 12-15                | 40-49                 |
| DXV/H024       | 86   | 6.00             | 113-138                 | 273-333                   | 9-11                 | 22-27                 | 154-188                 | 354-433                   | 10-12                | 41-50                 |
| DXV/H024       | 95   | 4.80             | 114-140                 | 316-386                   | 11-14                | 21-26                 | —                       | —                         | —                    | —                     |
| DXV/H024       | 95   | 6.00             | 114-140                 | 308-376                   | 9-11                 | 21-26                 | —                       | —                         | —                    | —                     |
| DXV/H036       | 32   | 7.20             | —                       | —                         | —                    | —                     | 69-85                   | 235-288                   | 5-6                  | 18-22                 |
| DXV/H036       | 32   | 9.00             | —                       | —                         | —                    | —                     | 71-86                   | 237-289                   | 4-5                  | 18-22                 |
| DXV/H036       | 45   | 7.20             | 112-137                 | 151-185                   | 11-13                | 22-27                 | 87-106                  | 263-322                   | 6-8                  | 22-27                 |
| DXV/H036       | 45   | 9.00             | 112-137                 | 146-178                   | 8-10                 | 22-27                 | 89-109                  | 265-324                   | 5-6                  | 23-28                 |
| DXV/H036       | 55   | 7.20             | 113-138                 | 178-217                   | 10-13                | 22-27                 | 103-126                 | 279-340                   | 7-9                  | 25-31                 |
| DXV/H036       | 55   | 9.00             | 113-138                 | 172-210                   | 8-10                 | 22-27                 | 106-129                 | 281-343                   | 6-7                  | 26-32                 |
| DXV/H036       | 68   | 7.20             | 114-140                 | 216-264                   | 10-12                | 21-26                 | 124-151                 | 301-368                   | 9-11                 | 29-36                 |
| DXV/H036       | 68   | 9.00             | 114-140                 | 210-257                   | 8-10                 | 21-26                 | 128-156                 | 304-372                   | 7-9                  | 30-37                 |
| DXV/H036       | 75   | 7.20             | 116-142                 | 237-290                   | 10-12                | 21-26                 | 138-169                 | 312-381                   | 9-12                 | 31-38                 |
| DXV/H036       | 75   | 9.00             | 116-142                 | 231-282                   | 8-10                 | 21-26                 | 143-174                 | 315-385                   | 8-9                  | 32-39                 |
| DXV/H036       | 86   | 7.20             | 118-145                 | 275-337                   | 10-12                | 21-25                 | 163-199                 | 327-400                   | 11-13                | 34-42                 |
| DXV/H036       | 86   | 9.00             | 118-144                 | 269-329                   | 8-10                 | 21-25                 | 169-207                 | 329-402                   | 9-10                 | 35-42                 |
| DXV/H036       | 95   | 7.20             | 120-146                 | 310-379                   | 10-12                | 20-25                 | —                       | —                         | —                    | —                     |
| DXV/H036       | 95   | 9.00             | 120-146                 | 304-371                   | 8-9                  | 20-25                 | —                       | —                         | —                    | —                     |
| DXV/H048       | 32   | 9.60             | —                       | —                         | —                    | —                     | 61-74                   | 233-285                   | 5-6                  | 17-21                 |
| DXV/H048       | 32   | 12.00            | —                       | —                         | —                    | —                     | 62-76                   | 235-287                   | 4-5                  | 18-22                 |
| DXV/H048       | 45   | 9.60             | 105-129                 | 164-201                   | 11-13                | 22-27                 | 75-92                   | 251-307                   | 6-7                  | 21-26                 |
| DXV/H048       | 45   | 12.00            | 105-128                 | 159-194                   | 9-11                 | 23-28                 | 77-94                   | 253-309                   | 5-6                  | 22-27                 |
| DXV/H048       | 55   | 9.60             | 108-131                 | 191-234                   | 11-13                | 22-27                 | 90-110                  | 265-324                   | 7-8                  | 24-30                 |
| DXV/H048       | 55   | 12.00            | 107-131                 | 186-227                   | 8-10                 | 22-27                 | 93-113                  | 267-327                   | 6-7                  | 25-31                 |
| DXV/H048       | 68   | 9.60             | 110-134                 | 232-283                   | 10-13                | 21-26                 | 108-132                 | 281-344                   | 8-10                 | 28-35                 |
| DXV/H048       | 68   | 12.00            | 110-134                 | 226-276                   | 8-10                 | 21-26                 | 111-136                 | 284-347                   | 7-8                  | 29-36                 |
| DXV/H048       | 75   | 9.60             | 114-139                 | 253-309                   | 10-13                | 21-26                 | 120-147                 | 292-357                   | 9-11                 | 31-38                 |
| DXV/H048       | 75   | 12.00            | 114-139                 | 247-301                   | 8-10                 | 21-26                 | 124-152                 | 295-360                   | 7-9                  | 31-38                 |



**Start-Up**

**Table 36. Operating pressures in cooling/heating for DX\* units (continued)**

| Operating Data |  |                  |                         |                           |                      |                       |                         |                           |                      |                       |
|----------------|--|------------------|-------------------------|---------------------------|----------------------|-----------------------|-------------------------|---------------------------|----------------------|-----------------------|
| Model          | Entering Water Temp Entering Water Temp (°F) | Water Flow (GPM) | Cooling                 |                           |                      |                       | Heating                 |                           |                      |                       |
|                |  |                  | Suction Pressure (psig) | Discharge Pressure (pgig) | Water Temp Rise (°F) | Air Temp Drop (°F DB) | Suction Pressure (psig) | Discharge Pressure (psig) | Water Temp Drop (°F) | Air Temp Rise (°F DB) |
| DXV/H048       | 86   | 9.60             | 117-143                 | 293-358                   | 10-12                | 21-25                 | 143-174                 | 308-376                   | 10-13                | 34-42                 |
| DXV/H048       | 86   | 12.00            | 116-142                 | 286-349                   | 8-10                 | 21-25                 | 148-181                 | 311-380                   | 8-10                 | 35-43                 |
| DXV/H048       | 95   | 9.60             | 118-144                 | 329-402                   | 10-12                | 20-25                 | —                       | —                         | —                    | —                     |
| DXV/H048       | 95   | 12.00            | 118-144                 | 322-394                   | 8-10                 | 20-25                 | —                       | —                         | —                    | —                     |
| DXV/H060       | 32   | 12.00            | —                       | —                         | —                    | —                     | 65-80                   | 234-286                   | 5-6                  | 17-21                 |
| DXV/H060       | 32   | 15.00            | —                       | —                         | —                    | —                     | 67-82                   | 236-288                   | 4-5                  | 18-22                 |
| DXV/H060       | 45   | 12.00            | 111-136                 | 161-197                   | 10-13                | 22-27                 | 80-98                   | 253-309                   | 6-7                  | 21-26                 |
| DXV/H060       | 45   | 15.00            | 111-136                 | 157-191                   | 8-10                 | 22-27                 | 83-101                  | 254-311                   | 5-6                  | 22-27                 |
| DXV/H060       | 55   | 12.00            | 113-138                 | 189-231                   | 10-13                | 21-26                 | 96-118                  | 266-325                   | 7-9                  | 24-30                 |
| DXV/H060       | 55   | 15.00            | 113-138                 | 183-224                   | 8-10                 | 21-26                 | 99-121                  | 268-328                   | 6-7                  | 25-30                 |
| DXV/H060       | 68   | 12.00            | 114-140                 | 229-280                   | 10-12                | 21-25                 | 116-142                 | 286-350                   | 8-10                 | 28-35                 |
| DXV/H060       | 68   | 15.00            | 114-140                 | 223-273                   | 8-10                 | 21-25                 | 120-147                 | 289-353                   | 7-8                  | 29-35                 |
| DXV/H060       | 75   | 12.00            | 117-144                 | 248-303                   | 10-12                | 21-25                 | 130-159                 | 296-362                   | 9-11                 | 30-37                 |
| DXV/H060       | 75   | 15.00            | 117-143                 | 242-296                   | 8-10                 | 21-25                 | 134-164                 | 299-366                   | 7-9                  | 31-38                 |
| DXV/H060       | 86   | 12.00            | 120-146                 | 286-349                   | 10-12                | 20-25                 | 154-188                 | 313-382                   | 10-13                | 34-41                 |
| DXV/H060       | 86   | 15.00            | 120-146                 | 280-342                   | 8-10                 | 20-25                 | 159-194                 | 316-386                   | 8-10                 | 34-42                 |
| DXV/H060       | 95   | 12.00            | 121-148                 | 322-393                   | 10-12                | 20-24                 | —                       | —                         | —                    | —                     |
| DXV/H060       | 95   | 15.00            | 121-148                 | 315-385                   | 8-9                  | 20-24                 | —                       | —                         | —                    | —                     |
| DXV/H070       | 32   | 14.00            | —                       | —                         | —                    | —                     | 66-81                   | 249-304                   | 6-7                  | 19-23                 |
| DXV/H070       | 32   | 17.50            | —                       | —                         | —                    | —                     | 68-83                   | 251-306                   | 5-6                  | 19-24                 |
| DXV/H070       | 45   | 14.00            | 102-125                 | 151-185                   | 10-12                | 21-26                 | 82-100                  | 270-330                   | 6-8                  | 23-29                 |
| DXV/H070       | 45   | 17.50            | 102-125                 | 146-179                   | 8-10                 | 21-26                 | 84-103                  | 272-333                   | 5-6                  | 24-29                 |
| DXV/H070       | 55   | 14.00            | 103-126                 | 178-217                   | 10-12                | 21-26                 | 98-120                  | 285-348                   | 8-9                  | 27-33                 |
| DXV/H070       | 55   | 17.50            | 103-126                 | 173-211                   | 8-10                 | 21-26                 | 101-123                 | 287-351                   | 6-8                  | 27-33                 |
| DXV/H070       | 68   | 14.00            | 105-129                 | 217-265                   | 10-12                | 20-25                 | 113-138                 | 302-369                   | 9-11                 | 30-37                 |
| DXV/H070       | 68   | 17.50            | 105-128                 | 211-258                   | 8-10                 | 20-25                 | 116-142                 | 305-373                   | 7-9                  | 31-37                 |
| DXV/H070       | 75   | 14.00            | 111-136                 | 240-294                   | 10-12                | 21-25                 | 126-154                 | 313-382                   | 9-12                 | 32-40                 |
| DXV/H070       | 75   | 17.50            | 111-136                 | 235-287                   | 8-10                 | 21-25                 | 130-159                 | 316-386                   | 8-10                 | 33-40                 |
| DXV/H070       | 86   | 14.00            | 114-139                 | 277-339                   | 10-12                | 20-25                 | 149-182                 | 330-403                   | 11-13                | 36-44                 |
| DXV/H070       | 86   | 17.50            | 114-139                 | 271-331                   | 8-10                 | 20-25                 | 154-188                 | 333-407                   | 9-11                 | 37-45                 |
| DXV/H070       | 95   | 14.00            | 115-141                 | 313-382                   | 10-12                | 20-24                 | —                       | —                         | —                    | —                     |
| DXV/H070       | 95   | 17.50            | 115-141                 | 306-374                   | 8-10                 | 20-24                 | —                       | —                         | —                    | —                     |



**Table 37. Operating pressures in cooling/heating for EX\* units**

| Operating Data |  |                  |                         |                           |                      |                       |                         |                           |                      |                       |
|----------------|--|------------------|-------------------------|---------------------------|----------------------|-----------------------|-------------------------|---------------------------|----------------------|-----------------------|
| Model          | Entering Water Temp Entering Water Temp (°F) | Water Flow (GPM) | Cooling                 |                           |                      |                       | Heating                 |                           |                      |                       |
|                |  |                  | Suction Pressure (psig) | Discharge Pressure (pgig) | Water Temp Rise (°F) | Air Temp Drop (°F DB) | Suction Pressure (psig) | Discharge Pressure (psig) | Water Temp Drop (°F) | Air Temp Rise (°F DB) |
| EXV/H009       | 32   | 1.80             | —                       | —                         | —                    | —                     | 67-82                   | 225-274                   | 5-6                  | 17-20                 |
| EXV/H009       | 32   | 2.25             | —                       | —                         | —                    | —                     | 69-84                   | 226-276                   | 4-5                  | 17-21                 |
| EXV/H009       | 45   | 1.80             | 108-132                 | 147-180                   | 11-13                | 23-28                 | 86-105                  | 243-297                   | 6-8                  | 22-27                 |
| EXV/H009       | 45   | 2.25             | 108-131                 | 142-173                   | 9-11                 | 23-28                 | 88-108                  | 245-299                   | 5-6                  | 22-27                 |
| EXV/H009       | 55   | 1.80             | 109-134                 | 176-216                   | 11-13                | 23-28                 | 102-125                 | 256-313                   | 7-9                  | 25-31                 |
| EXV/H009       | 55   | 2.25             | 109-134                 | 170-208                   | 9-11                 | 23-28                 | 105-129                 | 258-316                   | 6-7                  | 26-31                 |
| EXV/H009       | 68   | 1.80             | 112-137                 | 215-263                   | 11-13                | 22-27                 | 121-148                 | 273-334                   | 9-11                 | 30-36                 |
| EXV/H009       | 68   | 2.25             | 112-137                 | 210-256                   | 8-10                 | 22-27                 | 125-153                 | 276-337                   | 7-9                  | 30-37                 |
| EXV/H009       | 75   | 1.80             | 118-144                 | 237-289                   | 11-13                | 22-27                 | 135-165                 | 284-347                   | 10-12                | 32-39                 |
| EXV/H009       | 75   | 2.25             | 117-144                 | 230-282                   | 8-10                 | 22-27                 | 139-170                 | 287-351                   | 8-10                 | 33-40                 |
| EXV/H009       | 86   | 1.80             | 122-149                 | 276-338                   | 10-13                | 21-26                 | 158-193                 | 300-367                   | 11-14                | 35-43                 |
| EXV/H009       | 86   | 2.25             | 122-149                 | 270-330                   | 8-10                 | 21-26                 | 164-201                 | 304-372                   | 9-11                 | 36-44                 |
| EXV/H009       | 95   | 1.80             | 124-152                 | 310-379                   | 10-12                | 21-25                 | —                       | —                         | —                    | —                     |
| EXV/H009       | 95   | 2.25             | 124-151                 | 304-371                   | 8-10                 | 21-25                 | —                       | —                         | —                    | —                     |
| EXV/H012       | 32   | 2.40             | —                       | —                         | —                    | —                     | 68-83                   | 233-285                   | 5-6                  | 17-21                 |
| EXV/H012       | 32   | 3.00             | —                       | —                         | —                    | —                     | 69-85                   | 234-286                   | 4-5                  | 18-22                 |
| EXV/H012       | 45   | 2.40             | 105-128                 | 152-186                   | 11-13                | 23-28                 | 88-107                  | 251-307                   | 6-8                  | 23-28                 |
| EXV/H012       | 45   | 3.00             | 105-128                 | 146-179                   | 9-11                 | 23-28                 | 90-110                  | 253-310                   | 5-6                  | 23-28                 |
| EXV/H012       | 55   | 2.40             | 107-131                 | 182-222                   | 11-13                | 22-27                 | 104-128                 | 266-325                   | 7-9                  | 26-32                 |
| EXV/H012       | 55   | 3.00             | 107-131                 | 176-216                   | 9-11                 | 22-27                 | 107-131                 | 269-328                   | 6-7                  | 27-33                 |
| EXV/H012       | 68   | 2.40             | 110-134                 | 220-269                   | 10-13                | 22-26                 | 121-148                 | 284-347                   | 9-11                 | 31-38                 |
| EXV/H012       | 68   | 3.00             | 110-134                 | 215-263                   | 8-10                 | 22-26                 | 125-153                 | 287-351                   | 7-9                  | 32-39                 |
| EXV/H012       | 75   | 2.40             | 116-141                 | 239-293                   | 11-13                | 22-26                 | 135-165                 | 296-361                   | 10-12                | 33-41                 |
| EXV/H012       | 75   | 3.00             | 115-141                 | 233-285                   | 8-10                 | 22-26                 | 139-170                 | 300-366                   | 8-10                 | 34-42                 |
| EXV/H012       | 86   | 2.40             | 121-148                 | 276-338                   | 10-13                | 21-26                 | 158-193                 | 316-386                   | 12-14                | 37-46                 |
| EXV/H012       | 86   | 3.00             | 121-147                 | 270-330                   | 8-10                 | 21-26                 | 164-200                 | 320-392                   | 10-12                | 38-47                 |
| EXV/H012       | 95   | 2.40             | 123-150                 | 309-378                   | 10-12                | 20-25                 | —                       | —                         | —                    | —                     |
| EXV/H012       | 95   | 3.00             | 122-150                 | 303-370                   | 8-10                 | 21-25                 | —                       | —                         | —                    | —                     |
| EXV/H015       | 32   | 3.00             | —                       | —                         | —                    | —                     | 64-79                   | 241-294                   | 6-7                  | 20-24                 |
| EXV/H015       | 32   | 3.75             | —                       | —                         | —                    | —                     | 66-81                   | 242-296                   | 5-6                  | 20-25                 |
| EXV/H015       | 45   | 3.00             | 102-125                 | 157-192                   | 12-14                | 24-29                 | 82-100                  | 262-320                   | 7-8                  | 25-30                 |
| EXV/H015       | 45   | 3.75             | 102-125                 | 152-185                   | 9-12                 | 24-29                 | 85-103                  | 264-323                   | 6-7                  | 25-31                 |
| EXV/H015       | 55   | 3.00             | 104-127                 | 187-228                   | 12-14                | 23-29                 | 98-120                  | 278-340                   | 8-10                 | 28-34                 |
| EXV/H015       | 55   | 3.75             | 104-127                 | 181-221                   | 9-11                 | 23-29                 | 101-123                 | 281-344                   | 7-8                  | 29-35                 |
| EXV/H015       | 68   | 3.00             | 106-130                 | 225-275                   | 12-14                | 23-28                 | 115-141                 | 294-359                   | 9-11                 | 32-39                 |
| EXV/H015       | 68   | 3.75             | 106-130                 | 219-268                   | 9-11                 | 23-28                 | 119-145                 | 298-364                   | 8-9                  | 33-40                 |
| EXV/H015       | 75   | 3.00             | 110-134                 | 246-300                   | 12-14                | 23-28                 | 128-157                 | 307-375                   | 10-13                | 35-43                 |
| EXV/H015       | 75   | 3.75             | 110-134                 | 239-292                   | 9-11                 | 23-28                 | 133-162                 | 311-380                   | 8-10                 | 36-44                 |



**Start-Up**

**Table 37. Operating pressures in cooling/heating for EX\* units (continued)**

| Operating Data |   |                  |                         |                           |                      |                       |                         |                           |                      |                       |
|----------------|---|------------------|-------------------------|---------------------------|----------------------|-----------------------|-------------------------|---------------------------|----------------------|-----------------------|
| Model          | Entering Water Temp<br>Entering Water Temp (°F) | Water Flow (GPM) | Cooling                 |                           |                      |                       | Heating                 |                           |                      |                       |
|                |   |                  | Suction Pressure (psig) | Discharge Pressure (pgig) | Water Temp Rise (°F) | Air Temp Drop (°F DB) | Suction Pressure (psig) | Discharge Pressure (psig) | Water Temp Drop (°F) | Air Temp Rise (°F DB) |
| EXV/H015       | 86  | 3.00             | 113-139                 | 283-346                   | 11-14                | 22-27                 | 151-184                 | 327-400                   | 12-14                | 39-47                 |
| EXV/H015       | 86  | 3.75             | 113-138                 | 277-338                   | 9-11                 | 22-27                 | 156-191                 | 332-406                   | 10-12                | 40-48                 |
| EXV/H015       | 95  | 3.00             | 115-141                 | 316-386                   | 11-14                | 21-26                 | —                       | —                         | —                    | —                     |
| EXV/H015       | 95  | 3.75             | 115-140                 | 309-378                   | 9-11                 | 21-26                 | —                       | —                         | —                    | —                     |
| EXV/H018       | 32  | 3.60             | —                       | —                         | —                    | —                     | 62-76                   | 243-297                   | 6-7                  | 19-24                 |
| EXV/H018       | 32  | 4.50             | —                       | —                         | —                    | —                     | 64-78                   | 245-299                   | 5-6                  | 20-24                 |
| EXV/H018       | 45  | 3.60             | 105-128                 | 150-184                   | 12-15                | 24-29                 | 81-98                   | 258-316                   | 7-8                  | 24-29                 |
| EXV/H018       | 45  | 4.50             | 105-128                 | 144-177                   | 10-12                | 24-29                 | 83-101                  | 261-319                   | 5-7                  | 24-30                 |
| EXV/H018       | 55  | 3.60             | 106-130                 | 177-216                   | 12-14                | 23-28                 | 96-117                  | 274-335                   | 8-10                 | 27-33                 |
| EXV/H018       | 55  | 4.50             | 106-130                 | 170-208                   | 9-12                 | 23-29                 | 99-121                  | 277-338                   | 6-8                  | 28-34                 |
| EXV/H018       | 68  | 3.60             | 108-132                 | 214-262                   | 12-14                | 22-27                 | 112-137                 | 295-360                   | 9-11                 | 32-39                 |
| EXV/H018       | 68  | 4.50             | 108-132                 | 208-254                   | 9-11                 | 22-27                 | 116-141                 | 298-364                   | 8-9                  | 32-39                 |
| EXV/H018       | 75  | 3.60             | 111-136                 | 234-286                   | 12-14                | 22-27                 | 125-152                 | 307-375                   | 10-12                | 34-42                 |
| EXV/H018       | 75  | 4.50             | 111-136                 | 227-278                   | 9-11                 | 22-27                 | 129-158                 | 311-380                   | 8-10                 | 35-43                 |
| EXV/H018       | 86  | 3.60             | 114-139                 | 271-332                   | 11-14                | 21-26                 | 147-179                 | 326-399                   | 12-14                | 38-47                 |
| EXV/H018       | 86  | 4.50             | 114-139                 | 264-323                   | 9-11                 | 21-26                 | 152-186                 | 331-405                   | 10-12                | 39-48                 |
| EXV/H018       | 95  | 3.60             | 115-141                 | 304-372                   | 11-14                | 20-25                 | —                       | —                         | —                    | —                     |
| EXV/H018       | 95  | 4.50             | 115-140                 | 297-363                   | 9-11                 | 20-25                 | —                       | —                         | —                    | —                     |
| EXV/H024       | 32  | 4.80             | —                       | —                         | —                    | —                     | 61-74                   | 254-310                   | 6-7                  | 20-24                 |
| EXV/H024       | 32  | 6.00             | —                       | —                         | —                    | —                     | 62-76                   | 256-312                   | 5-6                  | 20-25                 |
| EXV/H024       | 45  | 4.80             | 102-125                 | 152-185                   | 12-14                | 23-29                 | 78-96                   | 277-339                   | 7-9                  | 26-31                 |
| EXV/H024       | 45  | 6.00             | 102-124                 | 146-179                   | 9-12                 | 24-29                 | 81-98                   | 280-342                   | 6-7                  | 26-32                 |
| EXV/H024       | 55  | 4.80             | 103-126                 | 178-218                   | 12-14                | 23-28                 | 93-114                  | 293-358                   | 8-10                 | 29-35                 |
| EXV/H024       | 55  | 6.00             | 103-126                 | 172-210                   | 9-11                 | 23-28                 | 96-118                  | 296-362                   | 7-8                  | 30-36                 |
| EXV/H024       | 68  | 4.80             | 105-128                 | 217-265                   | 11-14                | 22-27                 | 111-136                 | 317-387                   | 10-12                | 34-41                 |
| EXV/H024       | 68  | 6.00             | 105-128                 | 210-257                   | 9-11                 | 22-27                 | 115-141                 | 321-392                   | 8-10                 | 34-42                 |
| EXV/H024       | 75  | 4.80             | 108-133                 | 238-291                   | 12-14                | 22-27                 | 124-152                 | 329-402                   | 11-13                | 36-44                 |
| EXV/H024       | 75  | 6.00             | 108-132                 | 231-283                   | 9-11                 | 22-27                 | 129-157                 | 334-408                   | 9-11                 | 37-45                 |
| EXV/H024       | 86  | 4.80             | 111-136                 | 277-339                   | 11-14                | 21-26                 | 146-178                 | 349-426                   | 12-15                | 40-49                 |
| EXV/H024       | 86  | 6.00             | 111-136                 | 270-330                   | 9-11                 | 21-26                 | 152-186                 | 354-432                   | 10-12                | 41-50                 |
| EXV/H024       | 95  | 4.80             | 112-137                 | 312-382                   | 11-14                | 20-25                 | —                       | —                         | —                    | —                     |
| EXV/H024       | 95  | 6.00             | 112-137                 | 305-372                   | 9-11                 | 20-25                 | —                       | —                         | —                    | —                     |
| EXV/H030       | 32  | 6.00             | —                       | —                         | —                    | —                     | 66-80                   | 238-291                   | 6-7                  | 19-23                 |
| EXV/H030       | 32  | 7.50             | —                       | —                         | —                    | —                     | 67-82                   | 240-293                   | 5-6                  | 19-24                 |
| EXV/H030       | 45  | 6.00             | 109-133                 | 154-188                   | 12-15                | 24-29                 | 82-100                  | 266-325                   | 7-8                  | 24-29                 |
| EXV/H030       | 45  | 7.50             | 108-132                 | 148-181                   | 10-12                | 24-30                 | 84-103                  | 268-328                   | 5-7                  | 24-30                 |
| EXV/H030       | 55  | 6.00             | 110-134                 | 180-220                   | 12-14                | 24-29                 | 98-120                  | 282-344                   | 8-9                  | 27-33                 |
| EXV/H030       | 55  | 7.50             | 110-134                 | 174-213                   | 9-12                 | 24-29                 | 101-123                 | 284-348                   | 6-8                  | 27-34                 |

**Table 37. Operating pressures in cooling/heating for EX\* units (continued)**

| Operating Data |  |                  |                         |                           |                      |                       |                         |                           |                      |                       |
|----------------|--|------------------|-------------------------|---------------------------|----------------------|-----------------------|-------------------------|---------------------------|----------------------|-----------------------|
| Model          | Entering Water Temp Entering Water Temp (°F) | Water Flow (GPM) | Cooling                 |                           |                      |                       | Heating                 |                           |                      |                       |
|                |  |                  | Suction Pressure (psig) | Discharge Pressure (pgig) | Water Temp Rise (°F) | Air Temp Drop (°F DB) | Suction Pressure (psig) | Discharge Pressure (psig) | Water Temp Drop (°F) | Air Temp Rise (°F DB) |
| EXV/H030       | 68   | 6.00             | 111-136                 | 219-268                   | 11-14                | 23-28                 | 117-143                 | 306-375                   | 9-11                 | 31-38                 |
| EXV/H030       | 68   | 7.50             | 111-136                 | 212-260                   | 9-11                 | 23-28                 | 121-148                 | 310-379                   | 8-9                  | 32-39                 |
| EXV/H030       | 75   | 6.00             | 113-139                 | 241-295                   | 11-14                | 23-28                 | 130-159                 | 319-390                   | 10-12                | 34-41                 |
| EXV/H030       | 75   | 7.50             | 113-138                 | 234-286                   | 9-11                 | 23-28                 | 135-165                 | 323-395                   | 8-10                 | 35-42                 |
| EXV/H030       | 86   | 6.00             | 115-141                 | 280-342                   | 11-13                | 22-27                 | 154-188                 | 339-414                   | 11-14                | 37-46                 |
| EXV/H030       | 86   | 7.50             | 115-141                 | 273-333                   | 9-11                 | 22-27                 | 159-195                 | 344-420                   | 9-12                 | 38-47                 |
| EXV/H030       | 95   | 6.00             | 117-143                 | 316-386                   | 11-13                | 21-26                 | —                       | —                         | —                    | —                     |
| EXV/H030       | 95   | 7.50             | 117-143                 | 308-377                   | 9-10                 | 21-26                 | —                       | —                         | —                    | —                     |
| EXV/H036       | 32   | 7.20             | —                       | —                         | —                    | —                     | 65-79                   | 243-297                   | 6-7                  | 19-24                 |
| EXV/H036       | 32   | 9.00             | —                       | —                         | —                    | —                     | 66-81                   | 244-298                   | 5-6                  | 20-24                 |
| EXV/H036       | 45   | 7.20             | 108-132                 | 156-190                   | 11-14                | 23-28                 | 81-98                   | 272-332                   | 7-8                  | 24-29                 |
| EXV/H036       | 45   | 9.00             | 108-132                 | 150-184                   | 9-11                 | 23-28                 | 83-101                  | 274-335                   | 5-7                  | 24-30                 |
| EXV/H036       | 55   | 7.20             | 109-134                 | 183-224                   | 11-14                | 23-28                 | 96-118                  | 288-352                   | 8-9                  | 27-33                 |
| EXV/H036       | 55   | 9.00             | 109-134                 | 177-216                   | 9-11                 | 23-28                 | 99-121                  | 291-355                   | 6-8                  | 27-34                 |
| EXV/H036       | 68   | 7.20             | 111-136                 | 223-272                   | 11-13                | 22-27                 | 113-138                 | 311-380                   | 9-11                 | 31-38                 |
| EXV/H036       | 68   | 9.00             | 111-135                 | 216-264                   | 9-11                 | 22-27                 | 117-143                 | 314-384                   | 7-9                  | 31-38                 |
| EXV/H036       | 75   | 7.20             | 113-138                 | 244-298                   | 11-13                | 22-27                 | 126-154                 | 323-395                   | 10-12                | 33-41                 |
| EXV/H036       | 75   | 9.00             | 113-138                 | 237-290                   | 9-11                 | 22-27                 | 131-160                 | 328-400                   | 8-10                 | 34-41                 |
| EXV/H036       | 86   | 7.20             | 115-140                 | 283-346                   | 11-13                | 21-26                 | 149-182                 | 344-420                   | 11-14                | 37-45                 |
| EXV/H036       | 86   | 9.00             | 115-140                 | 276-337                   | 8-10                 | 21-26                 | 155-189                 | 348-426                   | 9-11                 | 38-46                 |
| EXV/H036       | 95   | 7.20             | 116-142                 | 319-390                   | 10-13                | 21-25                 | —                       | —                         | —                    | —                     |
| EXV/H036       | 95   | 9.00             | 116-142                 | 312-381                   | 8-10                 | 21-26                 | —                       | —                         | —                    | —                     |
| EXV/H042       | 32   | 8.40             | —                       | —                         | —                    | —                     | 63-77                   | 238-290                   | 5-7                  | 19-23                 |
| EXV/H042       | 32   | 10.50            | —                       | —                         | —                    | —                     | 65-79                   | 239-292                   | 4-5                  | 19-23                 |
| EXV/H042       | 45   | 8.40             | 106-129                 | 163-199                   | 11-14                | 23-28                 | 77-94                   | 253-310                   | 6-8                  | 22-27                 |
| EXV/H042       | 45   | 10.50            | 106-129                 | 158-193                   | 9-11                 | 23-28                 | 79-97                   | 255-312                   | 5-6                  | 23-28                 |
| EXV/H042       | 55   | 8.40             | 107-131                 | 191-233                   | 11-13                | 22-27                 | 92-113                  | 268-327                   | 7-9                  | 26-31                 |
| EXV/H042       | 55   | 10.50            | 107-131                 | 185-226                   | 9-11                 | 22-27                 | 95-116                  | 270-330                   | 6-7                  | 26-32                 |
| EXV/H042       | 68   | 8.40             | 109-133                 | 232-284                   | 11-13                | 22-27                 | 109-134                 | 287-351                   | 9-11                 | 30-36                 |
| EXV/H042       | 68   | 10.50            | 109-133                 | 226-276                   | 9-11                 | 22-27                 | 113-138                 | 291-355                   | 7-9                  | 30-37                 |
| EXV/H042       | 75   | 8.40             | 113-138                 | 254-311                   | 11-13                | 22-27                 | 122-149                 | 298-364                   | 10-12                | 32-39                 |
| EXV/H042       | 75   | 10.50            | 113-138                 | 247-302                   | 9-11                 | 22-27                 | 126-154                 | 302-369                   | 8-10                 | 33-40                 |
| EXV/H042       | 86   | 8.40             | 116-141                 | 295-361                   | 11-13                | 21-26                 | 144-176                 | 315-385                   | 11-13                | 36-44                 |
| EXV/H042       | 86   | 10.50            | 115-141                 | 288-352                   | 9-11                 | 21-26                 | 150-183                 | 318-389                   | 9-11                 | 36-45                 |
| EXV/H042       | 95   | 8.40             | 117-143                 | 332-406                   | 11-13                | 21-26                 | —                       | —                         | —                    | —                     |
| EXV/H042       | 95   | 10.50            | 117-143                 | 325-397                   | 9-10                 | 21-26                 | —                       | —                         | —                    | —                     |
| EXV/H048       | 32   | 9.60             | —                       | —                         | —                    | —                     | 64-78                   | 239-292                   | 5-6                  | 18-22                 |
| EXV/H048       | 32   | 12.00            | —                       | —                         | —                    | —                     | 65-80                   | 240-294                   | 4-5                  | 19-23                 |



**Start-Up**

**Table 37. Operating pressures in cooling/heating for EX\* units (continued)**

| Operating Data |  |                  |                         |                           |                      |                       |                         |                           |                      |                       |
|----------------|--|------------------|-------------------------|---------------------------|----------------------|-----------------------|-------------------------|---------------------------|----------------------|-----------------------|
| Model          | Entering Water Temp Entering Water Temp (°F) | Water Flow (GPM) | Cooling                 |                           |                      |                       | Heating                 |                           |                      |                       |
|                |  |                  | Suction Pressure (psig) | Discharge Pressure (pgig) | Water Temp Rise (°F) | Air Temp Drop (°F DB) | Suction Pressure (psig) | Discharge Pressure (psig) | Water Temp Drop (°F) | Air Temp Rise (°F DB) |
| EXV/H048       | 45   | 9.60             | 108-132                 | 163-199                   | 10-13                | 22-26                 | 77-94                   | 250-306                   | 6-7                  | 21-26                 |
| EXV/H048       | 45   | 12.00            | 108-132                 | 158-193                   | 8-10                 | 22-26                 | 79-96                   | 252-308                   | 5-6                  | 22-27                 |
| EXV/H048       | 55   | 9.60             | 109-133                 | 191-234                   | 10-13                | 21-26                 | 92-113                  | 264-323                   | 7-8                  | 24-30                 |
| EXV/H048       | 55   | 12.00            | 109-133                 | 186-227                   | 8-10                 | 21-26                 | 95-116                  | 266-325                   | 6-7                  | 25-30                 |
| EXV/H048       | 68   | 9.60             | 111-135                 | 233-285                   | 10-12                | 21-26                 | 109-133                 | 281-344                   | 8-10                 | 29-35                 |
| EXV/H048       | 68   | 12.00            | 111-135                 | 227-277                   | 8-10                 | 21-26                 | 112-137                 | 284-347                   | 7-8                  | 29-36                 |
| EXV/H048       | 75   | 9.60             | 114-139                 | 254-310                   | 10-13                | 21-26                 | 122-149                 | 292-356                   | 9-11                 | 31-38                 |
| EXV/H048       | 75   | 12.00            | 114-139                 | 248-303                   | 8-10                 | 21-26                 | 126-154                 | 295-360                   | 7-9                  | 32-39                 |
| EXV/H048       | 86   | 9.60             | 116-142                 | 293-359                   | 10-12                | 21-25                 | 144-176                 | 307-376                   | 10-13                | 34-42                 |
| EXV/H048       | 86   | 12.00            | 116-142                 | 287-350                   | 8-10                 | 21-25                 | 150-183                 | 311-380                   | 9-10                 | 35-43                 |
| EXV/H048       | 95   | 9.60             | 118-144                 | 330-403                   | 10-12                | 20-25                 | —                       | —                         | —                    | —                     |
| EXV/H048       | 95   | 12.00            | 118-144                 | 323-395                   | 8-10                 | 20-25                 | —                       | —                         | —                    | —                     |
| EXV/H060       | 32   | 12.00            | —                       | —                         | —                    | —                     | 61-75                   | 244-298                   | 6-7                  | 19-23                 |
| EXV/H060       | 32   | 15.00            | —                       | —                         | —                    | —                     | 63-77                   | 245-300                   | 5-6                  | 20-24                 |
| EXV/H060       | 45   | 12.00            | 106-129                 | 165-201                   | 12-14                | 23-28                 | 77-94                   | 262-320                   | 7-8                  | 23-28                 |
| EXV/H060       | 45   | 15.00            | 106-129                 | 159-195                   | 9-11                 | 23-28                 | 79-97                   | 264-323                   | 5-7                  | 24-29                 |
| EXV/H060       | 55   | 12.00            | 107-131                 | 192-235                   | 11-14                | 23-28                 | 92-113                  | 277-339                   | 8-9                  | 27-32                 |
| EXV/H060       | 55   | 15.00            | 107-131                 | 186-228                   | 9-11                 | 23-28                 | 95-116                  | 280-342                   | 6-8                  | 27-33                 |
| EXV/H060       | 68   | 12.00            | 108-133                 | 233-284                   | 11-14                | 22-27                 | 109-134                 | 298-364                   | 9-11                 | 31-37                 |
| EXV/H060       | 68   | 15.00            | 108-132                 | 226-276                   | 9-11                 | 22-27                 | 113-138                 | 301-368                   | 7-9                  | 31-38                 |
| EXV/H060       | 75   | 12.00            | 112-137                 | 253-309                   | 11-14                | 22-27                 | 122-149                 | 309-378                   | 10-12                | 33-40                 |
| EXV/H060       | 75   | 15.00            | 112-137                 | 246-301                   | 9-11                 | 22-27                 | 127-155                 | 313-382                   | 8-10                 | 34-41                 |
| EXV/H060       | 86   | 12.00            | 114-139                 | 292-357                   | 11-14                | 22-26                 | 145-177                 | 327-399                   | 11-13                | 36-45                 |
| EXV/H060       | 86   | 15.00            | 114-139                 | 285-349                   | 9-11                 | 22-26                 | 150-184                 | 331-404                   | 9-11                 | 37-45                 |
| EXV/H060       | 95   | 12.00            | 116-141                 | 329-402                   | 11-13                | 21-26                 | —                       | —                         | —                    | —                     |
| EXV/H060       | 95   | 15.00            | 115-141                 | 321-393                   | 9-11                 | 21-26                 | —                       | —                         | —                    | —                     |
| EXV/H070       | 32   | 14.00            | —                       | —                         | —                    | —                     | 61-75                   | 243-297                   | 5-6                  | 19-23                 |
| EXV/H070       | 32   | 17.50            | —                       | —                         | —                    | —                     | 63-77                   | 245-299                   | 4-5                  | 19-24                 |
| EXV/H070       | 45   | 14.00            | 102-124                 | 150-183                   | 10-12                | 21-26                 | 76-93                   | 260-318                   | 6-7                  | 22-27                 |
| EXV/H070       | 45   | 17.50            | 102-124                 | 146-178                   | 8-10                 | 21-26                 | 78-95                   | 262-320                   | 5-6                  | 23-28                 |
| EXV/H070       | 55   | 14.00            | 103-126                 | 176-215                   | 10-12                | 21-25                 | 91-112                  | 275-337                   | 7-8                  | 25-31                 |
| EXV/H070       | 55   | 17.50            | 103-126                 | 171-209                   | 8-10                 | 21-25                 | 94-115                  | 278-340                   | 6-7                  | 26-32                 |
| EXV/H070       | 68   | 14.00            | 105-128                 | 215-263                   | 10-12                | 20-25                 | 107-130                 | 295-361                   | 8-10                 | 29-36                 |
| EXV/H070       | 68   | 17.50            | 105-128                 | 209-256                   | 8-10                 | 20-25                 | 110-134                 | 298-365                   | 7-8                  | 30-36                 |
| EXV/H070       | 75   | 14.00            | 111-135                 | 239-292                   | 10-12                | 21-25                 | 119-146                 | 307-375                   | 9-11                 | 32-39                 |
| EXV/H070       | 75   | 17.50            | 111-135                 | 233-285                   | 8-10                 | 21-25                 | 123-150                 | 310-379                   | 7-9                  | 32-39                 |
| EXV/H070       | 86   | 14.00            | 113-138                 | 275-337                   | 10-12                | 20-25                 | 141-172                 | 324-396                   | 10-12                | 35-43                 |
| EXV/H070       | 86   | 17.50            | 113-138                 | 269-329                   | 8-10                 | 20-25                 | 146-179                 | 328-401                   | 8-10                 | 36-44                 |

**Table 37. Operating pressures in cooling/heating for EX\* units (continued)**

| Operating Data |  |                  |                         |                           |                      |                       |                         |                           |                      |                       |
|----------------|--|------------------|-------------------------|---------------------------|----------------------|-----------------------|-------------------------|---------------------------|----------------------|-----------------------|
| Model          | Entering Water Temp Entering Water Temp (°F) | Water Flow (GPM) | Cooling                 |                           |                      |                       | Heating                 |                           |                      |                       |
|                |  |                  | Suction Pressure (psig) | Discharge Pressure (pgig) | Water Temp Rise (°F) | Air Temp Drop (°F DB) | Suction Pressure (psig) | Discharge Pressure (psig) | Water Temp Drop (°F) | Air Temp Rise (°F DB) |
| EXV/H070       | 95   | 14.00            | 115-140                 | 311-380                   | 10-12                | 20-24                 | —                       | —                         | —                    | —                     |
| EXV/H070       | 95   | 17.50            | 115-140                 | 304-372                   | 8-10                 | 20-24                 | —                       | —                         | —                    | —                     |

## Water Pressure Drop

Use the following tables to define feet of head/pressure drop. Please note the feet of pressure (ft/head) provided is at AHRI/ISO standard.

To calculate feet of head, when using gauges that read in PSIG, multiply PSI by 2.31.

**Table 38. Cooling water pressure drop (WPD) in feet of head for DX\* units**

| Unit Size | EWT °F | GPM  | Ft. Pressure |
|-----------|--------|------|--------------|
| DXV/H024  | 86     | 6.0  | 2.8          |
| DXV/H036  | 86     | 9.0  | 6.0          |
| DXV/H048  | 86     | 12.0 | 6.4          |
| DXV/H060  | 86     | 15.0 | 11.2         |
| DXV/H070  | 86     | 17.5 | 9.4          |

**Table 39. Cooling water pressure drop (WPD) in feet of head for EX\* units**

| Unit Size (60 Hz) | EWT °F | GPM  | Ft. Pressure |
|-------------------|--------|------|--------------|
| EXV/H009          | 86     | 2.3  | 3.4          |
| EXV/H012          | 86     | 3.0  | 5.9          |
| EXV/H015          | 86     | 3.8  | 8.2          |
| EXV/H018          | 86     | 4.5  | 1.7          |
| EXV/H024          | 86     | 6.0  | 2.8          |
| EXV/H030          | 86     | 7.5  | 4.1          |
| EXV/H036          | 86     | 9.0  | 5.8          |
| EXV/H042          | 86     | 10.5 | 4.9          |
| EXV/H048          | 86     | 12.0 | 5.9          |
| EXV/H060          | 86     | 15.0 | 10.6         |
| EXV/H070          | 86     | 17.5 | 9.3          |

**Table 40. Heating water pressure drop (WPD) in feet of head for DX\* units**

| Unit Size | EWT °F | GPM  | Ft. Pressure |
|-----------|--------|------|--------------|
| DXV/H024  | 68     | 6.0  | 3.1          |
| DXV/H036  | 68     | 9.0  | 6.3          |
| DXV/H048  | 68     | 12.0 | 6.6          |
| DXV/H060  | 68     | 15.0 | 12.0         |
| DXV/H070  | 68     | 17.5 | 10.0         |

**Table 41. Heating water pressure drop (WPD) in feet of head for EX\* units**

| Unit Size (60 Hz) | EWT °F | GPM  | Ft. Pressure |
|-------------------|--------|------|--------------|
| EXV/H009          | 68     | 2.3  | 3.7          |
| EXV/H012          | 68     | 3.0  | 6.4          |
| EXV/H015          | 68     | —    | —            |
| EXV/H018          | 68     | 4.5  | 1.8          |
| EXV/H024          | 68     | 6.0  | 3.0          |
| EXV/H030          | 68     | 7.5  | 4.5          |
| EXV/H036          | 68     | 9.0  | 6.1          |
| EXV/H042          | 68     | 10.5 | 5.1          |
| EXV/H048          | 68     | 12.0 | 6.2          |
| EXV/H060          | 68     | 15.0 | 11.4         |
| EXV/H070          | 68     | 17.5 | 9.9          |



## Start-Up

### Water Volume

The information below is provided for use in calculating glycol requirements for the unit.

**Table 42. Water volume for DX\* units**

| Unit Size | Water Side Volume (in <sup>3</sup> ) | Water Side Volume (ft <sup>3</sup> ) | Water Side Volume (gallons) |
|-----------|--------------------------------------|--------------------------------------|-----------------------------|
| DXV/H024  | 118.6                                | 0.069                                | 0.513                       |
| DXV/H036  | 118.6                                | 0.069                                | 0.513                       |
| DXV/H048  | 196.5                                | 0.114                                | 0.851                       |
| DXV/H060  | 222.6                                | 0.129                                | 0.964                       |
| DXV/H070  | 284.0                                | 0.164                                | 1.229                       |

**Table 43. Water volume for EX\* units**

| Unit Size (60 Hz) | Water Side Volume (in <sup>3</sup> ) | Water Side Volume (ft <sup>3</sup> ) | Water Side Volume (gallons) |
|-------------------|--------------------------------------|--------------------------------------|-----------------------------|
| EXV/H009          | 34.6                                 | 0.02                                 | 0.15                        |
| EXV/H012          | 34.6                                 | 0.02                                 | 0.15                        |
| EXV/H015          | 41.0                                 | 0.024                                | 0.177                       |
| EXV/H018          | 118.6                                | 0.069                                | 0.513                       |
| EXV/H024          | 118.6                                | 0.069                                | 0.513                       |
| EXV/H030          | 118.6                                | 0.069                                | 0.513                       |
| EXV/H036          | 118.6                                | 0.069                                | 0.513                       |
| EXV/H042          | 196.5                                | 0.114                                | 0.851                       |
| EXV/H048          | 196.5                                | 0.114                                | 0.851                       |
| EXV/H060          | 222.6                                | 0.129                                | 0.964                       |
| EXV/H070          | 284.0                                | 0.164                                | 1.229                       |



# Maintenance

## ⚠ WARNING

### Hazardous Service Procedures!

Failure to follow all precautions in this manual and on the tags, stickers, and labels could result in death or serious injury.

Technicians, in order to protect themselves from potential electrical, mechanical, and chemical hazards, **MUST** follow precautions in this manual and on the tags, stickers, and labels, as well as the following instructions: Unless specified otherwise, disconnect all electrical power including remote disconnect and discharge all energy storing devices such as capacitors before servicing. Follow proper lockout/tagout procedures to ensure the power can not be inadvertently energized. When necessary to work with live electrical components, have a qualified licensed electrician or other individual who has been trained in handling live electrical components perform these tasks.

*Note: These units must be serviced by approved personnel only.*

## Preventative Maintenance

Maintenance on the unit is simplified with the following preventive suggestions:

Filter maintenance must be performed to assure proper operation of the equipment. Filters should be inspected at least every three months, and replaced when it is evident they are dirty. Filter sizing is shown below.

**Table 44. Filter sizing DX\* models**

| Size | Filter Size (Nominal) inches |
|------|------------------------------|
| DXHK |                              |
| 024  | 18 x 23                      |
| 036  | 20 x 30                      |
| 048  | 20 x 20 (Qty = 2)            |
| 060  | 20 x 20 and 30 x 20          |
| 070  | 20 x 20 and 30 x 20          |
| DXVK |                              |
| 024  | 18 x 23                      |
| 036  | 20 x 30                      |
| 048  | 27 x 30                      |
| 060  | 30 x 33                      |
| 070  | 30 x 33                      |

**Table 44. Filter sizing DX\* models (continued)**

| Size | Filter Size (Nominal) inches |
|------|------------------------------|
|------|------------------------------|

**Table 45. Filter sizing EX\* models**

| Size | Filter Size (Nominal) inches |
|------|------------------------------|
| EXHK |                              |
| 009  | 16 x 19                      |
| 012  | 16 x 19                      |
| 015  | 17 x 20                      |
| 018  | 18 x 23                      |
| 024  | 18 x 23                      |
| 030  | 20 x 30                      |
| 036  | 20 x 30                      |
| 042  | 20 x 20 (Qty = 2)            |
| 048  | 20 x 20 (Qty = 2)            |
| 060  | 20 x 20 and 30 x 20          |
| 070  | 20 x 20 and 30 x 20          |
| EXVK |                              |
| 009  | 16x19                        |
| 012  | 16x19                        |
| 015  | 17x20                        |
| 018  | 18x23                        |
| 024  | 18x23                        |
| 030  | 20x30                        |
| 036  | 20x30                        |
| 042  | 27x30                        |
| 048  | 27x30                        |
| 060  | 33x30                        |
| 070  | 30x33                        |

Check the contactors and relays within the control panel at least once a year. It is good practice to check the tightness of the various wiring connections within the control panel.

A strainer (60 mesh or greater) must be used on an open loop system to keep debris from entering the unit heat exchanger and to confirm a clean system.

For units on well water, it is important to check the cleanliness of the water-to-refrigerant heat exchanger. Should it become contaminated with dirt and scaling as a result of bad water, the heat exchanger will have to be back flushed and cleaned with a chemical that will remove the

scale. This service should be performed by an experienced service person.

### ⚠ WARNING

#### Hazardous Chemicals!

Failure to follow this safety precaution could result in death or serious injury. Coil cleaning agents can be either acidic or highly alkaline and can burn severely if contact with skin or eyes occurs.

Handle chemical carefully and avoid contact with skin. ALWAYS wear Personal Protective Equipment (PPE) including goggles or face shield, chemical resistant gloves, boots, apron or suit as required. For personal safety refer to the cleaning agent manufacturer's Materials Safety Data Sheet and follow all recommended safe handling practices.

It should be noted that the water quality should be checked periodically (See below).

**Table 46. Water quality**

| Scaling                                | Amount            |
|--|-------------------|
| Calcium and magnesium (total hardness) | Less than 350 ppm |
| Corrosion                              |                   |
| pH                                     | 7-9.5             |

**Table 46. Water quality (continued)**

| Scaling                      | Amount             |
|------------------------------|--------------------|
| Hydrogen Sulfide             | Less than 1 ppm    |
| Sulfates                     | Less than 25 ppm   |
| Chlorides                    | Less than 125 ppm  |
| Carbon Dioxide               | Less than 75 ppm   |
| Total dissolved solids (TDS) | Less than 1000 ppm |
| Biological Growth            |                    |
| Iron Bacteria                | Low                |
| Erosion                      |                    |
| Suspended Solids             | Low                |

## Condensate Trap

For units incorporating a negative trap design, confirm that the condensate system is primed with water at all times. Allowing a negative pressure condensate system to run dry could cause a break in the condensate seal allowing the fan to draw water from the condensate line to spray moisture into the mechanical system. By maintaining a primed condensate trap, a seal is created that prevents these complications.





# Troubleshooting

## ⚠ WARNING

### Hazardous Service Procedures!

Failure to follow all precautions in this manual and on the tags, stickers, and labels could result in death or serious injury.

Technicians, in order to protect themselves from potential electrical, mechanical, and chemical hazards, **MUST** follow precautions in this manual and on the tags, stickers, and labels, as well as the following instructions: Unless specified otherwise, disconnect all electrical power including remote disconnect and discharge all energy storing devices such as capacitors before servicing. Follow proper lockout/tagout procedures to ensure the power can not be inadvertently energized. When necessary to work with live electrical components, have a qualified licensed electrician or other individual who has been trained in handling live electrical components perform these tasks.

## Deluxe Controls

Troubleshooting units containing the deluxe control option is easy using the three light emitting diodes (LEDs). These LEDs are provided for indicating the operating mode of the controller and are labeled on the circuit board with numbers as referenced in the table below.

Table 47. Diagnostic LEDs

| Color: Green | Color: Red |       | Controller Mode                      |
|--------------|------------|-------|--------------------------------------|
| LED1         | LED2       | LED3  |                                      |
| OFF          | OFF        | OFF   | Control OFF                          |
| ON           | OFF        | OFF   | Normal/Compressor OFF                |
| ON           | OFF        | FLASH | Anti-short cycle                     |
| ON           | OFF        | ON    | Normal/Compressor ON                 |
| FLASH        | ON         | OFF   | Brownout Condition                   |
| ON           | FLASH      | ON    | Soft Lockout (low pressure)          |
| ON           | FLASH      | FLASH | Soft Lockout (high pressure)         |
| ON           | ON         | ON    | Manual Lockout (low pressure)        |
| ON           | ON         | FLASH | Manual Lockout (high pressure)       |
| ON           | FLASH      | OFF   | Manual Lockout (condensate overflow) |
| ON           | ON         | OFF   | Compressor Disable                   |

Table 48. Troubleshooting table

| Problem                               | Heat-<br>ing | Cool-<br>ing | Cause                                   | Correction        |
|---------------------------------------|--------------|--------------|---|-------------------|
| No response to any thermostat setting |              |              |   |                   |
|                                       | X            | X            | Main power off                          | Check fuses       |
|                                       | X            | X            | Defective control transformer           | Replace           |
|                                       | X            | X            | Broken or loose connection              | Repair            |
|                                       | X            | X            | Defective thermostat                    | Replace           |
|                                       | X            | X            | Transformer                             | Reset Transformer |
| Unit short cycles                     | X            | X            | Thermostat or sensor improperly located | Relocate          |



## Troubleshooting

**Table 48. Troubleshooting table (continued)**

| Problem                              | Heat-<br>ing | Cool-<br>ing              | Cause  | Correction  |
|--------------------------------------|--------------|---------------------------|--|---|
| Blower runs, but compressor does not | X            | X                         | Defective compressor overload                    | Replace (if external)   |
|                                      | X            | X                         | Defective compressor contactor                   | Replace   |
|                                      | X            | X                         | Supply Voltage too low                           | Correct   |
|                                      | X            | X                         | Defective compressor capacitor                   | Replace   |
|                                      | X            | X                         | Defective windings                               | Replace   |
|                                      | X            | X                         | Limit switches open                              | Check cause/Replace or repair                                 |
| Insufficient capacity                | X            | X                         | Dirty filter                                     | Replace/clean   |
|                                      | X            | X                         | Blower RPM too low                               | Correct   |
|                                      | X            | X                         | Loss of conditioned air due to leaks in ductwork | Repair leaks  |
|                                      |              | X                         | Introduction of excessively hot return-air       | Correct   |
|                                      | X            |                           | Introduction of excessively cold return-air      | Correct   |
|                                      | X            | X                         | Low on refrigerant charge                        | Locate leak, repair and recharge by weight (not by superheat) |
|                                      | X            | X                         | Restricted thermal expansion valve               | Replace   |
|                                      | X            | X                         | Defective reversing valve                        | See WSHP-IOM-# for touch test chart                           |
|                                      | X            | X                         | Thermostat improperly located                    | Relocate  |
|                                      | X            | X                         | Unit undersized                                  | Recalculate heat gains/losses                                 |
|                                      | X            | X                         | Inadequate water flow                            | Increase GPM  |
|                                      | X            | X                         | Scaling in heat exchanger                        | Clean or replace  |
|                                      |              | X                         | Water too hot                                    | Decrease temperature  |
|                                      | X            |                           | Water too cold                                   | Increase temperature  |
| X                                    | X            | Filter drier blocked      | Replace  |   |
| X                                    | X            | Defective reversing valve | Check or replace                                 |   |
| High pressure switch open            |              | X                         | Inadequate GPM                                   | Increase water flow to unit                                   |
|                                      |              | X                         | Water too hot                                    | Decrease temperature  |
|                                      | X            |                           | Inadequate air flow                              | Check, clean blower and coil                                  |
|                                      | X            |                           | Dirty filter                                     | Clean/replace   |
|                                      | X            | X                         | Overcharged with refrigerant                     | Decrease charge   |
|                                      | X            | X                         | Defective pressure switch                        | Check or replace  |
| High head pressure                   |              | X                         | Trash in heat exchanger                          | Backflush   |
|                                      |              | X                         | Low water flow                                   | Increase GPM  |
|                                      | X            | X                         | Overcharge of refrigerant                        | Decrease charge   |
|                                      | X            | X                         | Non-condensable in system                        | Evacuate and recharge by weight                               |
|                                      | X            | X                         | Water too hot                                    | Decrease temperature  |
|                                      | X            |                           | Dirty filter                                     | Clean / replace   |
|                                      | X            |                           | Inadequate air flow                              | Check, clean blower and coil                                  |

**Table 48. Troubleshooting table (continued)**

| Problem                  | Heat-<br>ing | Cool-<br>ing | Cause                              | Correction                       |
|--------------------------|--------------|--------------|------------------------------------|----------------------------------|
| Low suction pressure     | X            | X            | Undercharged                       | Locate leak, repair and recharge |
|                          | X            | X            | Restricted thermal expansion valve | Repair / replace                 |
|                          |              | X            | Inadequate air flow                | Check, clean blower and coil     |
|                          |              | X            | Dirty filter                       | Clean/replace                    |
|                          | X            |              | Inadequate GPM                     | Increase GPM                     |
| Low pressure switch open | X            |              | Inadequate GPM                     | Increase GPM                     |
|                          | X            |              | Water too cold                     | Increase temperature             |
|                          |              | X            | Inadequate air flow                | Increase CFM                     |
|                          |              | X            | Dirty filter                       | Clean/replace                    |
|                          | X            | X            | Undercharged with refrigerant      | Increase charge                  |
|                          | X            | X            | Defective pressure switch          | Replace                          |
|                          | X            | X            | Heat transfer fluid too cold       | Raise water temperature          |



# Wiring Diagram

This section contains wiring diagrams and isolation valve wiring connections.

**Table 49. Isolation valve wiring connections (0.5 to 5 tons)**

| Control Type | 3-Wire Isolation Valve Connections |       |      |
|--------------|------------------------------------|-------|------|
|              | Common                             | Close | Open |
| Deluxe 24V   | 93B                                | 92B   | 91B  |

**Note:** For field installed valves, wires 91B, 92B and 93B are coiled behind control box. For field-provided two wire valves connect to wires 91B and 93B.

**Note:** Wiring diagrams can be accessed via e-Library by entering the diagram number in the literature order number search field or by calling technical support.

**Table 50. Wiring diagram matrix for 0.5 to 6 tons GEV/H, EXV/H, and DXV/H models**

| Number   | Unit Description   | Model    |
|----------|--|----------|
| 23115845 | DELUXE CONTROLS 2 STAGE HEAT PUMP w/ECM MOTOR, SINGLE PHASE                              | DX only  |
| 23115846 | DELUXE CONTROLS HEAT PUMP w/HOT GAS REHEAT AND ECM MOTOR, SINGLE PHASE                   | EX/GE    |
| 23115847 | DELUXE CONTROLS HEAT PUMP w/WATER SIDE ECONOMIZER AND ECM MOTOR, SINGLE PHASE            | EX/GE    |
| 23115848 | DELUXE CONTROLS HEAT PUMP w/ECM MOTOR, SINGLE PHASE                                      | EX/GE    |
| 23115849 | DELUXE CONTROLS 2 STAGE HEAT PUMP w/ECM MOTOR, THREE PHASE                               | DX only  |
| 23115850 | DELUXE CONTROLS HEAT PUMP w/HOT GAS REHEAT AND ECM MOTOR, THREE PHASE                    | EX/GE    |
| 23115851 | DELUXE CONTROLS HEAT PUMP w/WATER SIDE ECONOMIZER AND ECM MOTOR, THREE PHASE             | EX/GE    |
| 23115852 | DELUXE CONTROLS HEAT PUMP w/ECM MOTOR, THREE PHASE                                       | EX/GE    |
| 23115861 | SYMBIO™ 400-B CONTROLS w/ECM MOTOR, SINGLE PHASE   | EX/DX/GE |
| 23115862 | SYMBIO™ 400-B CONTROLS w/ECM MOTOR, THREE PHASE  | EX/DX/GE |
| 23116088 | DELUXE CONTROLS 2 STAGE HEAT PUMP w/HOT GAS REHEAT, SINGLE PHASE                         | DXV/H    |
| 23116089 | DELUXE CONTROLS 2 STAGE HEAT PUMP w/HOT GAS REHEAT, THREE PHASE                          | DXV/H    |
| 23116151 | DELUXE CONTROLS HEAT PUMP w/BOILERLESS ELECTRIC HEAT, SINGLE PHASE                       | EX/GE    |
| 23116152 | DELUXE CONTROLS HEAT PUMP w/BOILERLESS ELECTRIC HEAT, THREE PHASE                        | EX/GE    |
| 23116153 | 400-B CONTROLS HEAT PUMP w/BOILERLESS ELECTRIC HEAT CONTROL, SINGLE PHASE                | EX/DX/GE |
| 23116154 | 400-B CONTROLS HEAT PUMP w/BOILERLESS ELECTRIC HEAT CONTROL, THREE PHASE                 | EX/DX/GE |
| 23116156 | 400-B CONTROLS HEAT PUMP AND HOT GAS REHEAT w/BOILERLESS ELEC HEAT CONTROL, SINGLE PHASE | EX/DX/GE |
| 23116157 | 400-B CONTROLS HEAT PUMP AND HOT GAS REHEAT w/BOILERLESS ELEC HEAT CONTROL, THREE PHASE  | EX/DX/GE |



## Warranty Information

### Standard Warranty

The standard water-source heat pump warranty is Trane's parts-only warranty, running 12 months from startup, not to exceed 18-months from shipment.

There is a standard 5-year compressor warranty.

### Extended Warranty

The optional extended warranty is a second through fifth year warranty. The time starts at the end of the standard 1 year coverage through the fifth year.

These extended warranties apply only to new equipment installed in domestic Trane Commercial Systems Group sales territories and must be ordered prior to start-up.



**Notes**

---



Trane - by Trane Technologies (NYSE: TT), a global innovator - creates comfortable, energy efficient indoor environments for commercial and residential applications. For more information, please visit [trane.com](http://trane.com) or [tranetechnologies.com](http://tranetechnologies.com).

Trane has a policy of continuous product and product data improvements and reserves the right to change design and specifications without notice. We are committed to using environmentally conscious print practices.

WSHP-SVX019C-EN 28 Feb 2025  
Supersedes WSHP-SVX019B-EN (October 2024)

©2025 Trane