



Installation, Operation, and Maintenance

Remote-Mounted Medium Voltage

Air-Cooled Adaptive Frequency™

Drive with Tracer Symbio™

Control



Model : VFDB

⚠ SAFETY WARNING

Only qualified personnel should install and service the equipment. The installation, starting up, and servicing of heating, ventilating, and air-conditioning equipment can be hazardous and requires specific knowledge and training. Improperly installed, adjusted or altered equipment by an unqualified person could result in death or serious injury. When working on the equipment, observe all precautions in the literature and on the tags, stickers, and labels that are attached to the equipment.

December 2024

VFDB-SVX001D-EN

TRANE
TECHNOLOGIES



Introduction

Read this manual thoroughly before operating or servicing this unit.

Warnings, Cautions, and Notices

Safety advisories appear throughout this manual as required. Your personal safety and the proper operation of this machine depend upon the strict observance of these precautions.

The three types of advisories are defined as follows:

- WARNING** Indicates a potentially hazardous situation which, if not avoided, could result in death or serious injury.
- CAUTION** Indicates a potentially hazardous situation which, if not avoided, could result in minor or moderate injury. It could also be used to alert against unsafe practices.
- NOTICE** Indicates a situation that could result in equipment or property-damage only accidents.

Important Environmental Concerns

Scientific research has shown that certain man-made chemicals can affect the earth's naturally occurring stratospheric ozone layer when released to the atmosphere. In particular, several of the identified chemicals that may affect the ozone layer are refrigerants that contain Chlorine, Fluorine and Carbon (CFCs) and those containing Hydrogen, Chlorine, Fluorine and Carbon (HCFCs). Not all refrigerants containing these compounds have the same potential impact to the environment. Trane advocates the responsible handling of all refrigerants-including industry replacements for CFCs and HCFCs such as saturated or unsaturated HFCs and HCFCs.

Important Responsible Refrigerant Practices

Trane believes that responsible refrigerant practices are important to the environment, our customers, and the air conditioning industry. All technicians who handle refrigerants must be certified according to local rules. For the USA, the Federal Clean Air Act (Section 608) sets forth the requirements for handling, reclaiming, recovering and recycling of certain refrigerants and the equipment that is used in these service procedures. In addition, some states or municipalities may have additional requirements that must also be adhered to for responsible management of refrigerants. Know the applicable laws and follow them.

WARNING

Proper Field Wiring and Grounding Required!

Failure to follow code could result in death or serious injury. All field wiring **MUST** be performed by qualified personnel. Improperly installed and grounded field wiring poses **FIRE** and **ELECTROCUTION** hazards. To avoid these hazards, you **MUST** follow requirements for field wiring installation and grounding as described in NEC and your local/state/national electrical codes.

WARNING

Personal Protective Equipment (PPE) Required!

Failure to wear proper PPE for the job being undertaken could result in death or serious injury. Technicians, in order to protect themselves from potential electrical, mechanical, and chemical hazards, **MUST** follow precautions in this manual and on the tags, stickers, and labels, as well as the instructions below:

- Before installing/servicing this unit, technicians **MUST** put on all PPE required for the work being undertaken (Examples; cut resistant gloves/sleeves, butyl gloves, safety glasses, hard hat/bump cap, fall protection, electrical PPE and arc flash clothing). **ALWAYS** refer to appropriate Safety Data Sheets (SDS) and OSHA guidelines for proper PPE.
- When working with or around hazardous chemicals, **ALWAYS** refer to the appropriate SDS and OSHA/GHS (Global Harmonized System of Classification and Labeling of Chemicals) guidelines for information on allowable personal exposure levels, proper respiratory protection and handling instructions.
- If there is a risk of energized electrical contact, arc, or flash, technicians **MUST** put on all PPE in accordance with OSHA, NFPA 70E, or other country-specific requirements for arc flash protection, **PRIOR** to servicing the unit. **NEVER PERFORM ANY SWITCHING, DISCONNECTING, OR VOLTAGE TESTING WITHOUT PROPER ELECTRICAL PPE AND ARC FLASH CLOTHING. ENSURE ELECTRICAL METERS AND EQUIPMENT ARE PROPERLY RATED FOR INTENDED VOLTAGE.**

⚠ WARNING**Follow EHS Policies!**

Failure to follow instructions below could result in death or serious injury.

- All Trane personnel must follow the company's Environmental, Health and Safety (EHS) policies when performing work such as hot work, electrical, fall protection, lockout/tagout, refrigerant handling, etc. Where local regulations are more stringent than these policies, those regulations supersede these policies.
- Non-Trane personnel should always follow local regulations.

⚠ WARNING**Refrigerant May Be Under Positive Pressure!**

Failure to follow instructions below could result in an explosion which could result in death or serious injury or equipment damage.

System contains refrigerant and may be under positive pressure; system may also contain oil. Recover refrigerant to relieve pressure before opening the system. See unit nameplate for refrigerant type. Do not use non-approved refrigerants, refrigerant substitutes, or non-approved refrigerant additives.

Revision History

- Replaced Tracer AdaptiView™ with Symbio™ in the document.
- Added A-Frame: Front view and A-Frame: Bottom view figures to the Cabinet chapter.

Copyright

This document and the information in it are the property of Trane, and may not be used or reproduced in whole or in part without written permission. Trane reserves the right to revise this publication at any time, and to make changes to its content without obligation to notify any person of such revision or change.

Trademarks

All trademarks referenced in this document are the trademarks of their respective owners. VFDB-SVX001D-EN

Factory Training

Factory training is available through Trane University™ to help you learn more about the operation and maintenance of your equipment. To learn about available training opportunities contact Trane University™.

Online: www.trane.com/traneuniversity

Phone: 855-803-3563

Email: traneuniversity@trane.com



Table of Contents

Overview	6	Storage	36
CE for MV Drives	7	Mechanical Installation	37
Checks	7	Install Drive panel	37
Motor Checks	7	Connect Shipping Splits	37
Controller Checks	7	Affix Cabinets to Floor	38
Visual Inspection	8	Install Input Starter	39
VFDB Checks	8	Anchoring	39
Rockwell Medium Voltage		Load Cable Connections	40
PowerFlex 6000T Drives	9	Install Main Cooling Fans	40
Typical Configurations	9	Install the cooling fan for A-frame drives	
Cabinet	9	(6.6 kV)	41
Cabinet Energy Sources	9	Wiring	42
Cabinet Design	9	Input Power, Input Starter to Drive Panel,	
Cabinet Voltage Levels	9	Drive to Motor, and Control Wiring	42
PowerFlex 6000T Medium Voltage Cabinet .	9	Installing Input Power Wiring	
Control Voltage Power		Standard Cabinet	42
De-energization	10	Torquing Electrical Power Connections . . .	43
Back-feed Sources of Hazardous		Cabinet Wire Routing	43
Electrical Energy	11	Wire Routing	43
General Information	12	Wire Sizing	43
About This Manual	12	Grounding the Cabinet	43
Other Required Manuals	12	Detailed Field Wiring Points	47
Cabinet Servicing	12	Input Power and Interconnection Wiring . .	47
Service Information	12	Pre-Commissioning Start-Up	49
Parts Ordering Information	12	Trane VFDB MV Drive	49
Scope of Installation and		Check List	49
Commissioning Responsibilities	12	Commissioning	49
About the VFDB Drive	13	Start-Up Commissioning Services	49
Drive Identification	13	Drive Commissioning	49
Model Number Descriptions	14	Start-Up Test Log	50
Trane Service Model Number	14	Maintenance	51
Model Number Digit Identification	14	Preventive Maintenance Check List	51
Cabinet	15	Operational Maintenance	51
Pre-Installation	34	Annual Maintenance	51
Receipt Inspection	34	Power Connection Inspection	51
Shipment list	34	Physical Inspection	51
Overhead Lifting	34	Chiller Operator Display Content	52
Lift the Power Module/LV Control Cabinet .	34	Troubleshooting	53
Lift Input Starter	36	Alarms	53

Troubleshooting	53
LED Usage	55
PowerFlex “A” or “B” Frame Pre-Commissioning Check List	1
Remote-Mounted Medium Voltage Air-Cooled Adaptive Frequency™ Drives: PowerFlex 7000 (Model: AFDJ) PowerFlex 6000T (Model: VFDB)	1
Instructions	2
PowerFlex “A” or “B” Frame Pre-Commissioning Check List	3



Overview

⚠ WARNING

Hazardous Service Procedures!

Failure to follow all precautions in this manual and on the tags, stickers, and labels could result in death or serious injury.

Technicians, in order to protect themselves from potential electrical, mechanical, and chemical hazards, **MUST** follow precautions in this manual and on the tags, stickers, and labels, as well as the following instructions: Unless specified otherwise, disconnect all electrical power including remote disconnect and discharge all energy storing devices such as capacitors before servicing. Follow proper lockout/tagout procedures to ensure the power can not be inadvertently energized. When necessary to work with live electrical components, have a qualified licensed electrician or other individual who has been trained in handling live electrical components perform these tasks.

⚠ WARNING

Hazardous Voltage!

Failure to disconnect power before servicing could result in death or serious injury.

Disconnect all electric power, including remote disconnects before servicing. Follow proper lockout/tagout procedures to ensure the power can not be inadvertently energized. Verify that no power is present with a voltmeter.

All electrical circuits shall be treated as energized until all lockout/tagout procedures are in place and the circuit has been tested to verify that it is de-energized. The medium voltage motor terminal box cover must not be removed if power is present, or if there is a possibility that power may be present. Working on energized medium voltage circuits is not an approved practice for normal HVAC maintenance or service.

⚠ WARNING

Hazardous Voltage w/Capacitors!

Failure to follow instructions below could result in death or serious injury.

Disconnect all electric power, including remote disconnects and discharge all motor start/run capacitors before servicing. Follow proper lockout/tagout procedures to ensure the power cannot be inadvertently energized. For variable frequency drives or other energy storing components provided by Trane or others, refer to the appropriate manufacturer's literature for allowable waiting periods for discharge of capacitors. If this equipment is interlocked with other equipment, 115 volt AC may be present in the cabinet even though the main power is disconnected. Interlock signals must be deactivated by qualified personnel prior to any work in the cabinet.

Verify with an appropriate voltmeter that all capacitors have discharged, and interlock signals have been deactivated from all circuits.

⚠ WARNING

Capacitors Must be Allowed to Discharge!

Failure to follow instructions below could result in death or serious injury.

Each time power is removed, allow at least 20 minutes for DC units to discharge after power is disconnected before servicing. Use extreme caution when applying power. Equipment terminals and other internal parts of the controller are at line voltage when ac power is connected to the controller. All ungrounded conductors of the ac power line must be disconnected from the controller before it is safe to touch any internal parts of this equipment.

Important:

- Before servicing, disconnect all power sources and allow at least 20 minutes for capacitors to discharge.
- All electrical enclosures-unit or remote-are IP2X.

CE for MV Drives

⚠ WARNING

Lockout/Tagout Before Removing Touch-Safe Covers!

Failure to follow instructions regarding touch-safe covers could result in death or serious injury. Touch-safe covers inside panels are there for protection and may be removed if necessary for service only and only after disconnection of main power supply. Before removing any touch-safe cover, ensure that there is no line power first. Removal of touch-safe covers is at the customer/service personnel's own risk. After any service is completed, if the touch-safe covers have been removed, they need to be put back in to ensure safety and protection.

Important:

- All Trane-supplied remote drives used in conjunction with CVHH or CDHH Trane chillers will be CE-compliant per EU directives and IEC standards to which the CVHH and CDHH chillers also comply. All Trane-supplied remote starters and drives must be used with CVHH or CDHH Trane chillers to ensure CE compliance
- For remote drives, basic details are provided on drive nameplate. Please refer to the chiller unit nameplate located on the chiller-mounted control panel for details on wire sizing (minimum current ampacity) and overcurrent protection sizing upstream of unit (maximum overcurrent protection).
- Always refer to as-built schematic wiring diagram and the chiller Installation, Operation, and Maintenance manual located inside the chiller-mounted control panel (regardless of unit or remote-mounted starter or drive) for details on wiring, safety, installation, and warnings.
- Customers are responsible for all field wiring with respect to EMC and EMI interference. Customers are responsible for mitigating the risks associated with EMC and EMI interference that can occur as a result of customer-provided field wiring as dictated by international, national, and local codes. This also implies that for remote-mounted drives, customers are responsible for the entire field wiring into the drive as well as between the drive and the chiller/compressor terminals with respect to EMC and EMI interference. It also implies that customers are responsible for incoming power wiring to the drive with respect to EMC and EMI interference.

All customer wiring, including power wiring to drives, must be separated: 24–27 Vdc, 110–120 Vac, 460 V, and 2300–6600 Vac each must be in separate conduit runs.

For remote drives interfacing with Trane CVHH and CDHH chillers, all wiring must be run in conduit. Any Ethernet cables being used by the customer to interface with the Trane chiller must be shielded Ethernet cabling.

The customer is required to provide an overcurrent protective device upstream of all drives in accordance with IEC standards and/or any applicable national and local codes.

Service personnel must use proper PPE for servicing and must also use proper lockout/tagout procedures during servicing: lock the drive disconnect handle before servicing to prevent accidental pulling of disconnect handle at the drive panel.

In addition, service personnel should disconnect the main supply disconnecting device upstream of the drive *before* performing any service on any part of the chiller.

Checks

Motor Checks

NOTICE

Do Not Megohm Test!

Using a megohm test to perform continuity checks in the drive equipment could result in damage to the controller circuitry.

1. Check the motor for proper horsepower and voltage ratings. Verify that the chiller rated load amps do not exceed the nameplate rating of the controller.
2. Check that the motor terminals are correctly connected to the controller's power terminals for the proper voltage and motor rotation.

NOTICE

Disconnect Motor Leads!

Failure to disconnect all motor leads at the AFD prior to mugging the motor could result in equipment damage.

3. Use an ohmmeter to check for any short circuits between the motor frame and the motor power leads. If a short circuit exists, it must be corrected before proceeding.

Controller Checks

1. Check that local, state and national electric codes have been observed for the installation and wiring of this equipment.
2. Check that all external power wiring has been properly routed through the cabinet.
3. Check all input power and output power connections for tightness.
4. Check the chassis ground and other connections for tightness.
5. Check all external control connections (this includes the operator station connections) for tightness.
6. Check to assure incoming power to the drive is phased A, B, C.

Visual Inspection

NOTICE

Equipment Damage!

Powering up equipment with an impaired condition as outlined below could cause equipment damage. Do not power up equipment if equipment condition concerns exist.

Before powering up the drive for the first time, conduct a visual inspection for the following:

- Shipping damage
- Moisture (or indications of moisture)
- Debris or dust
- Corrosion of components and/or enclosure

Do not power up equipment if any of these conditions are present.

Upon initial power up, remain in the area for the first two hours of operation, and observe the chiller and drive for any abnormalities.

Contact Trane technical support for assistance if needed.

VFDB Checks

⚠ WARNING

Hazardous Voltage!

Failure to follow instructions below could result in death, serious injury, or equipment damage. Do not remove or insert control boards or fuses while input power is connected to the controller.

⚠ WARNING

Electrical Shock Hazard!

Failure to follow instructions below could result in death or serious injury. Close all enclosure doors and properly secure with fasteners before operating equipment.

Important:

- Before servicing, disconnect all power sources and allow at least 20 minutes for capacitors to discharge.
- All electrical enclosures-unit or remote-are IP2X.

Safety Precautions

1. This equipment must be adjusted and serviced by qualified personnel familiar with the construction and operation of the equipment and the hazards involved.
2. Be sure the input disconnect is in the correct position, either “on” or “off” depending on the work to be performed.
3. Check the status of the drive shutdown interlocks, if used. These interlocks can be limit switches, guards or safety

switches installed around the driven machine or the system interface controller.

⚠ WARNING

Bypassed Electrical Interlocks!

Failure to follow instructions below could result in death, serious injury or equipment damage. The electrical interlocks provide machine and personal protection. If deactivated or bypassed for servicing, use extreme caution when performing the start-up. Return all interlocks to operation when the start-up is completed.

4. Check to see that the VFDB is properly ground to earth. Refer to “Grounding the Cabinet,” p. 43 in “Input Power, Input Starter to Drive Panel, Drive to Motor, and Control Wiring,” p. 42.

⚠ WARNING

Proper Field Wiring and Grounding Required!

Failure to follow code could result in death or serious injury. All field wiring **MUST** be performed by qualified personnel. Improperly installed and grounded field wiring poses FIRE and ELECTROCUTION hazards. To avoid these hazards, you **MUST** follow requirements for field wiring installation and grounding as described in NEC and your local/state/national electrical codes.

⚠ WARNING

Hazardous Voltage!

Failure to follow instructions below could result in death, serious injury, or equipment damage. Do not remove or insert control boards or fuses while input power is connected to the controller.

Important:

- Before servicing, disconnect all power sources and allow at least 20 minutes for capacitors to discharge.
- All electrical enclosures-unit or remote-are IP2X.
- Specific safety training for medium-voltage (MV) equipment, specialized tools and instruments for working on MV products, and enhanced personal protective equipment (PPE) that is designed to mitigate the hazards of arc flash injuries are required for working on the products described in this literature. Only medium-voltage trained, certified engineers are allowed to work on MV products.

Please refer to Rockwell’s MV product manual for details on recommendations to be followed for different components.

Rockwell Medium Voltage PowerFlex 6000T Drives

⚠ WARNING

Hazardous Service Procedures!

Failure to follow all precautions in this manual and on the tags, stickers, and labels could result in death or serious injury.

Technicians, in order to protect themselves from potential electrical, mechanical, and chemical hazards, **MUST** follow precautions in this manual and on the tags, stickers, and labels, as well as the following instructions: Unless specified otherwise, disconnect all electrical power including remote disconnect and discharge all energy storing devices such as capacitors before servicing. Follow proper lockout/tagout procedures to ensure the power can not be inadvertently energized. When necessary to work with live electrical components, have a qualified licensed electrician or other individual who has been trained in handling live electrical components perform these tasks.

Note: For questions regarding these procedures, contact your local Trane or Rockwell office.

Typical Configurations

The Trane-supplied Medium Voltage VFDB drives include two parts: input starter and drive panel. The drive panel is available in two air-cooled versions, called Frames:

1) 6000T A-Frame, and 2) 6000T B-Frame. Each Frame is specified based on the physical size and horse power (HP) or KW rating of the equipment. Generally, A-Frame is the smallest frame air-cooled drive, and B-Frame is the largest air-cooled drive. The following Rockwell Safe Electric Work Practices (SEWP) applies to typical configurations for PowerFlex 6000T drives.

Cabinet

Cabinet Energy Sources

A typical PowerFlex 6000T drive has a main medium voltage power supply and two other secondary control voltages power supply. In addition, a customer may specify a configuration with additional energy sources such as a UPS back-up power supply.

- Your responsibility is to look for all sources of hazardous energy to confirm the drive you will service or maintain matches the drawing.
- You must identify each source of power supplied to the cabinet and implement steps to control the each power source prior to performing your work.
- Other safety measures may have to be implemented for work such as removing cabinet tray covers/power cages to check the condition of “snubber capacitors” prior to performing the work.

Cabinet Design

Medium voltage cabinet doors are key interlock controlled and designed to open in sequence.

- Cabinet doors must only be opened in the engineered sequence and must be treated as if they are live until de-energization is verified.
- Control voltage cabinet door are black in color and can be opened without a key. The inside of the control voltage cabinet must be treated as if they are live until de-energization is verified.

The key interlocking scheme is a cornerstone of the safety devices built into a product. You are not authorized to work on, and must refuse to work on any installed MV product where the key interlocks are missing, damaged or compromised in any way. Keys can never be duplicated without the owner of the product signing a waiver. Service personnel should never be in possession of their own duplicate keys.

Match the personal protective equipment (PPE) you use to the voltage level and the hazard category to make sure that you have the correct protection for the specific work you are doing. The PPE must be adequate to protect against shock as well as arc flash injury.

Cabinet Voltage Levels

⚠ WARNING

Hazardous Voltage!

Failure to follow instructions below could result in death, serious injury.

Voltages upstream of the drive may exceed drive voltages. Only authorized personnel should de-energize upstream equipment.

For the purpose of medium voltage technical work, medium voltage is defined as 1,000–15,000 volts. Rockwell Automation medium voltage products presently range from 2,300~13,800 volt. The control voltage is defined as 600 volts or less. It is typically 480 or 120 volts. Some cabinets also have 5–24 Vdc power supply hooked up to them for logic circuit boards or indicator meters.

Voltages upstream of the drive may exceed drive voltages. Only authorized personnel should de-energize upstream equipment.

PowerFlex 6000T Medium Voltage Cabinet

Medium Voltage Power De-energization

Drive, Disconnect, or Breaker

- Put on the Personal Protective Equipment (PPE) necessary to protect from the shock and arc flash hazards from both medium and control voltages.
- Disconnect the MV input power source to the PowerFlex 6000T drive cabinets by placing the drive control; disconnect handle or circuit breaker switch in the “OFF” position.

Overview

- Apply the Lockout-Tagout device(s) and lock(s).
- The drive cabinet doors are locked and the input power control box must remain closed when de-energizing the MV power source.
 - Placing the control, handle or switch in the "Off" position should de-energized the power only down stream from the cabinet.
 - Medium voltage power remains energized upstream of the control, handle or switch.
- Use a properly rated meter to verify the medium voltage power on the downstream side of the drive/disconnect/breaker is de-energized.
 - Follow meter test procedures to confirm the meter is reading accurately prior to verifying de-energization.
- Remove the key from the de-energized drive/disconnect/breaker and use the key control procedure to open the MV cabinet access door(s).
- Use a medium voltage rated Potential Indicator tool ("hot stick") to confirm the medium voltage power inside the PowerFlex 6000T cabinet is de-energized.
 - Follow Potential Indicator tool test procedures to confirm the tool is working properly prior to verifying de-energization.
- The PPE for medium voltage safety can only be removed once the MV power de-energization is verified and confirmed. The PPE for control voltage can only be removed once the control voltage de-energization is verified.

⚠ WARNING

Hazardous Voltage w/Capacitors!

Failure to follow instructions below could result in death or serious injury. Disconnect all electric power, including remote disconnects and discharge all motor start/run capacitors before servicing. Follow proper lockout/tagout procedures to ensure the power cannot be inadvertently energized. For variable frequency drives or other energy storing components provided by Trane or others, refer to the appropriate manufacturer's literature for allowable waiting periods for discharge of capacitors. If this equipment is interlocked with other equipment, 115 volt AC may be present in the cabinet even though the main power is disconnected. Interlock signals must be deactivated by qualified personnel prior to any work in the cabinet. Verify with an appropriate voltmeter that all capacitors have discharged, and interlock signals have been deactivated from all circuits.

⚠ WARNING

Capacitors Must be Allowed to Discharge!

Failure to follow instructions below could result in death or serious injury. Each time power is removed, allow at least 20 minutes for DC units to discharge after power is disconnected before servicing. Use extreme caution when applying power. Equipment terminals and other internal parts of the controller are at line voltage when ac power is connected to the controller. All ungrounded conductors of the ac power line must be disconnected from the controller before it is safe to touch any internal parts of this equipment.

Important:

- Before servicing, disconnect all power sources and allow at least 20 minutes for capacitors to discharge.
- All electrical enclosures-unit or remote-are IP2X.

Control Voltage Power De-energization

⚠ WARNING

Hazardous Service Procedures!

Failure to follow all precautions in this manual and on the tags, stickers, and labels could result in death or serious injury. Technicians, in order to protect themselves from potential electrical, mechanical, and chemical hazards, **MUST** follow precautions in this manual and on the tags, stickers, and labels, as well as the following instructions: Unless specified otherwise, disconnect all electrical power including remote disconnect and discharge all energy storing devices such as capacitors before servicing. Follow proper lockout/tagout procedures to ensure the power can not be inadvertently energized. When necessary to work with live electrical components, have a qualified licensed electrician or other individual who has been trained in handling live electrical components perform these tasks.

Note: For questions regarding these procedures, contact your local Trane or Rockwell office.

- Wear the PPE that is necessary to protect from the shock and arc flash hazards.
- Disconnect the control voltage. Apply the lockout lock(s) and/or the tagout device(s).
- Identify the PowerFlex 6000T cabinet control power supply.
 - The source may be a disconnect switch on an electric circuit, an input contactor mounted on the side of the cabinet or similar power disconnect device.
 - Identify other sources of control voltage by reviewing the system drawings and looking at the equipment for secondary power sources.
- Some cabinets are equipped with a UPS battery backup 120 volt AC power supply for control voltage.

- The control voltage from the UPS battery backup will not be de-energized by disconnecting the control voltage disconnect switch. It is designed to energize once the primary control voltage source is de-energized.
- Use the PPE necessary to protect against UPS power.
- Use a properly rated meter to verify the control voltage power on the downstream side of the disconnect device is de-energized.
- Place the control voltage from the Rockwell Automation installed circuit breaker on the panel inside the control voltage supply cabinet in the “off” position.
 - The circuit breakers are normally located at the bottom of the circuit breaker terminal block strip.
 - Lockout-Tagout the switch. If a lockout is not feasible then tagout the circuit breaker to warn other people working in the same area not to turn the switch back on as it will re-energize the control circuit and may cause harm or injury to the person working on the equipment.
- If the primary and secondary control voltage sources are not de-energized during the work, you must continue to use your PPE while performing the work.
- Prevent back-feed power by locking, blocking or by other measures to positively control back-feed power sources.
- Verify these sources are positively controlled to prevent back-feed.

Back-feed Sources of Hazardous Electrical Energy

WARNING

Hazardous Service Procedures!

Failure to follow all precautions in this manual and on the tags, stickers, and labels could result in death or serious injury.

Technicians, in order to protect themselves from potential electrical, mechanical, and chemical hazards, **MUST** follow precautions in this manual and on the tags, stickers, and labels, as well as the following instructions: Unless specified otherwise, disconnect all electrical power including remote disconnect and discharge all energy storing devices such as capacitors before servicing. Follow proper lockout/tagout procedures to ensure the power can not be inadvertently energized. When necessary to work with live electrical components, have a qualified licensed electrician or other individual who has been trained in handling live electrical components perform these tasks.

Note: For questions regarding these procedures, contact your local Trane or Rockwell office.

- Back-feed power caused by a fan that rotates from ambient wind blowing on it, electric motor(s) rotating when equipment manually moves it and other potential sources of back-feed power may be downstream from the MV cabinet.
 - Identify sources of potential back-feed power downstream from the MV cabinet.



General Information

About This Manual

This manual is intended for use by experienced service personnel, qualified electrical personnel, Trane service personnel, and Rockwell global technical service personnel who are familiar with the features described.

The instructions in this manual outline the procedures for operating the Adaptive Frequency Drive. Operation and maintenance of the controls are also explained in this manual.

Other Required Manuals

Rockwell provides drive-size order-specific literature that ships with the drive from the Rockwell factory.

Cabinet Servicing

For information regarding the servicing of drive components, please refer to the appropriate Rockwell literature that ships with the drive.

Service Information

This equipment should be installed, adjusted and serviced by qualified electrical maintenance personnel who are familiar with the construction and operation of the equipment and the hazards involved, as defined in the National Electrical Code. Trane assumes no liability for installation or service procedures performed by unqualified personnel.

Parts Ordering Information

Refer to the model number printed on the Trane Adaptive Frequency Drive nameplate when ordering replacement parts or service for the drive. When ordering parts, contact the local Trane Parts Office in your area. For service, contact a qualified service organization.

Scope of Installation and Commissioning Responsibilities

Table 1. Scope of installation and commissioning responsibilities

Item	Others	Trane	Rockwell	See Figures/Pages
Chiller (provided by Trane)	—	X	—	—
Inspect chiller for shipping damage	X	Assist if any questions	—	—
Drive (provided by Trane from Rockwell)	—	—	Direct ship from Rockwell	—
Inspect drive for shipping damage	X	—	—	—
Provide drive foundation	X	—	—	—
Uncrate/package drive and inspect	X	—	—	—
Rig drive into place	X	—	—	—
Provide power wires and installation to drive and terminate:	X	—	—	—
• Line 3-phase voltage to drive; be sure to do this before fan shroud installation (A-Frame only)		—	—	—
• Fan 3-phase voltage to drive (B-Frame)		—	—	—
• Drive to motor power wiring		—	—	—
• Control power drive to chiller; interconnect (LV)		—	—	—
Install fan shroud boxes	X	—	—	—
Install resistor box	X	—	—	—
Provide adequate ventilation for heat rejection of drive	X	—	—	—
Precommission chiller; refer to chiller IOM forms	—	X	—	—
Fill out drive precommission check sheet	Assist Trane	X	—	—
Precommission drive	—	X	Assist	—
Apply 120 V	—	Assist	X	—
Apply power (3-phase)	—	Assist	X	—
Check/Configure drive controls setpoints with Trane Service Tool	—	X	Assist	—
3-phase power (DO NOT APPLY)	—	—	Present at start-up	—
Drive/chiller start-up	—	Assist	X	—
Annual inspections	—	X	X	As specified

About the VFDB Drive

The VFDB Trane Adaptive Frequency Drive is an air-cooled drive which uses Cascaded “H” Bridge (CHB) topology. This topology combines an integrally mounted phase-shifting isolation transformer with series-connected power cells for each phase. It can achieve low input harmonics and near-unity power factor. The Total Harmonic Distortion (THD) of the input current is within IEEE-519 harmonic guidelines. Both current and voltage waveforms are near sinusoidal, reducing stress on the motor windings.

A combination of two distinct operating modes make up the control within the chiller’s Symbio 800 control: first, by controlling the inlet guide vanes and second, by modulating the impeller speed from 38–60 hertz. The drive controls the speed in response to the Symbio 800 compressor control signal.

The CenTraVac control panel has full control of unit operation, including the start and stop functions. If a fault condition is encountered, or an alarm on the drive, the Tracer AdaptiView display will indicate “alarm” and an “Alarm message”.

Other Features

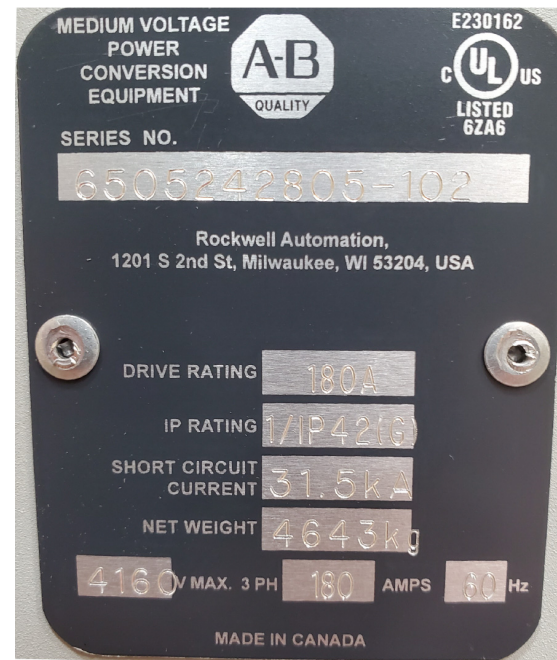
- Totally isolated low voltage and medium voltage compartments.
- Mechanical and electrical interlocks between the drive and input disconnecting means.
- Double offset ventilation pattern on the drive doors to ensure operator safety.
- Input Voltage Tolerance: $\pm 10\%$ of Nominal Line Voltage
- Input Frequency: 50/60 Hz, $\pm 10\%$
- Output Voltage Rating: 0–2300, 0–3300, 0–4160, 0–6600
- Input Protection: Distribution Class Heavy Duty Surge Arrestors
- Control Method: Sensorless Vector Control
- Ambient Temperature: 32°F–104°F (0°C– 40°C)
- Cooling: Forced Air
- Relative Humidity: Maximum 95% Non-condensing
- Altitude: 3300 feet (1000 m) above sea level without derating.

Drive Identification

The drive has a Trane model number and a Rockwell series number. Both these are extremely important when identifying the drive for service or parts. Refer to [“Model Number Descriptions,” p. 14](#) for more information about the Trane model number.

The Rockwell series number is shown on the Rockwell drive nameplate (see [Figure 1](#)), which is located on the outside of the drive enclosure. This series number should be available for reference in any correspondence with Trane and/or Rockwell. The chiller series number and chiller sales order number should also be available for reference.

Figure 1. Example: MV Rockwell drive nameplate



Note: This 650XXXXXX-XXX number identifies the drive. Always have this number ready when service is required.



Model Number Descriptions

Trane Service Model Number

An example of a typical chiller starter model number is:

VFDB0035NA0B00CDA

Model Number Digit Identification

Model number digits are selected and assigned in accordance with the following definitions using the model number example shown above:

Digit 1, 2, 3 — CenTraVac Starter

VFD = Variable Frequency Drive

Digit 4— Development Sequence

B = Medium Voltage Air-Cooled

Digit 5, 6, 7, 8 — Starter Size

Use Rated Load Amps (RLA) value

Digit 9 — Unit Line Voltage

K = 2300V-60Hz-3Ph
L = 2400V-60Hz-3Ph
N = 4160V-60Hz-3Ph
P = 3300V-60Hz-3Ph
X = 6600V-60Hz-3 Ph
V = 3300V-50Hz-3Ph
Z = 6600V-50Hz-3 Ph
S = Special

Digit 10, 11 — Design Sequence

A0 = First Design

Digit 12 — Starter Type

B = Remote Mounted

Digit 13 — Agency Listing

0 = UL and CUL Listed
(Standard on All Units)
1 = CE

Digit 14 — Special Options

0 = None
S = Special Options

Digit 15 — VFD Frame Size (SRRL)

A = 39
B = 49
C = 59
D = 77
E = 78
F = 85
G = 101
H = 106
J = 116
K = 118
L = 121
M = 128
N = 141
P = 161
Q = 180
R = 186
T = 193
U = 216
V = 251
W = 265
X = 286

Digit 16 — Display

D = Display

Digit 17 — Line Side Wire Entry

A = Top
B = Bottom



Cabinet

The cabinet has a NEMA 1 enclosure rating.

Environmental Conditions

Important: Location of the VFDB drive is important if proper performance and operating life is to be expected. Therefore, unless designated for special environments, the controller should be installed in an area where the following conditions exist.

- Verify that the NEMA 1 enclosure can be kept clean and dry.

- The area chosen should allow the space required for proper air flow. Refer to [Table 2, p. 15](#) and [Table 3, p. 16](#). Ensure the equipment room addresses the heat rejections requirements.
- Be sure the enclosure is installed in a non-corrosive location that is away from oil, coolants, or other airborne contaminants.
- Verify and maintain design hertz and voltage inputs.

Table 2. A-Frame weights^(a) and heat rejection

SRRL	LINE VOLTAGE-FREQUENCY	VFD AMPS	Motor HP	MAX HEAT REJECTION BTU/HR	MAX NUMBER AND SIZE OF CABLES (NEMA)			ESTIMATED WEIGHT LB	FIGURE			
					LINE TO INPUT STARTER	INPUT STARTER TO DRIVE PANEL	DRIVE PANEL OUTPUT TO MOTOR					
161	2300/2400V-60Hz	160	700	71310	400 AWG 6.6KV/phase	400 AWG 6.6KV/phase	400 AWG 6.6KV/phase	11880	C			
216	2300/2400V-60Hz	215	900	92470				11880	C			
77	3300V-50/60Hz	77	422	47770	400 AWG 6.6KV/phase	400 AWG 6.6KV/phase	400 AWG 6.6KV/phase	8360	B			
118	3300V-50/60Hz	118	671	68580				8360	B			
141	3300V-50/60Hz	140	805	81210				8360	B			
186	3300V-50/60Hz	186	1073	103050				11880	C			
216	3300V-50/60Hz	215	1207	117380				11880	C			
39	4160V-60Hz	40	300	30370				400 AWG 6.6KV/phase	400 AWG 6.6KV/phase	400 AWG 6.6KV/phase	5512	A
59	4160V-60Hz	59	450	44020	5512	A						
78	4160V-60Hz	78	600	63120	8360	A						
101	4160V-60Hz	100	700	74040	8360	B						
106	4160V-60Hz	105	800	79800	8360	B						
116	4160V-60Hz	116	900	89060	8360	B						
128	4160V-60Hz	128	1000	97900	8360	B						
141	4160V-60Hz	140	1100	106800	8360	B						
161	4160V-60Hz	160	1250	119760	11880	C						
180	4160V-60Hz	180	1415	135460	11880	C						
193	4160V-60Hz	193	1500	143300	11880	C						
216	4160V-60Hz	215	1600	160370	11880	C						
49	6600V-50/60Hz	50	603	58000	500 AWG 8KV or 15KV/phase	500 AWG 8KV or 15KV/phase	500 AWG 8KV or 15KV/phase				8254	A
85	6600V-50/60Hz	85	1006	100320							9769	B
101	6600V-50/60Hz	100	1207	116350				10386	B			
121	6600V-50/60Hz	120	1502	139560				10849	B			
141	6600V-50/60Hz	140	1676	157300				11091	B			

(a) Weights do not include 500 lb (226.8 kg) maximum shipping skid.



Cabinet

Table 3. B-Frame weights^(a) and heat rejection

SRRL	LINE VOLTAGE-FREQUENCY	VFD AMPS	Motor HP	MAX HEAT REJECTION BTU/HR	MAX NUMBER AND SIZE OF CABLES (NEMA)			WEIGHT LB	FIGURE
					LINE TO INPUT STARTER	INPUT STARTER TO DRIVE PANEL	DRIVE PANEL OUTPUT TO MOTOR		
251	2300/2400V-60Hz	250	1180	119080	1200 kcmil 5KV or 8KV/phase	1200 kcmil 5KV or 8KV/phase	1200 kcmil 5KV or 8KV/phase	10802	A
286	2300/2400V-60Hz	285	1314	134100				10802	A
251	3300V-50/60Hz	250	1623	144000	1200 kcmil 5KV or 8KV/phase	1200 kcmil 5KV or 8KV/phase	1200 kcmil 5KV or 8KV/phase	12789	B
265	3300V-50/60Hz	265	1676	151840				12789	B

(a) Weights do not include 500 lb (226.8 kg) maximum shipping skid.

A-Frame and B-Frame Notes

General Notes

Note: Refer to [Figure 2, p. 17](#) through [Figure 22, p. 33](#).

- Connections are spaced horizontally with dimension/location shown in the front view.
- NEMA 1 enclosure.
- Maximum remote distance between drive and chiller is 150 ft (45.72 m).

Cable Notes

- Top entry conduit openings standard.

Important: On A-Frame units with top entry and/or exit for the power cables, 24 inches of clearance on the left side is recommended for side access. As a result, the recommended is to mount the input starter cabinet on the right side of the drive.

- Field-configurable for bottom entry line power.
- All cable connections are bolted type; lugs provided by others.
- Cable space designed for non-shielded cable or shielded cable with prefabricated stress cones.
- Maximum cable information refer to [Table 2](#) and [Table 3](#)

Shipping Note

- Mounted on a (500 lb [226.8 kg] max) wooden skid with provisions for a fork truck. Lifting means also supplied on top.

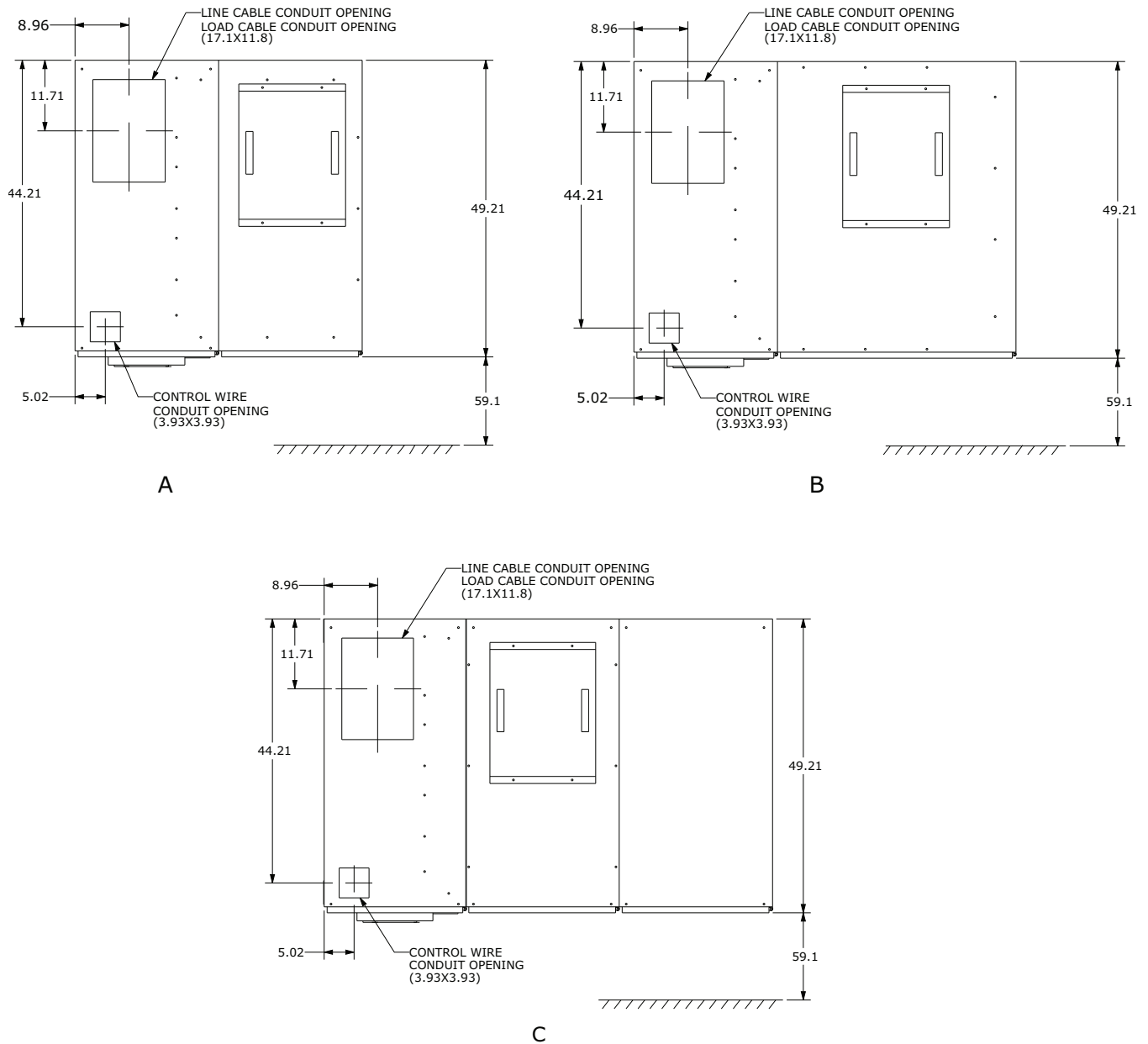
Figure 2. A-Frame: Top view (VFD 2300/3300/4160V), in.

Figure 3. A-Frame: Top view (VFD 6600V), in.

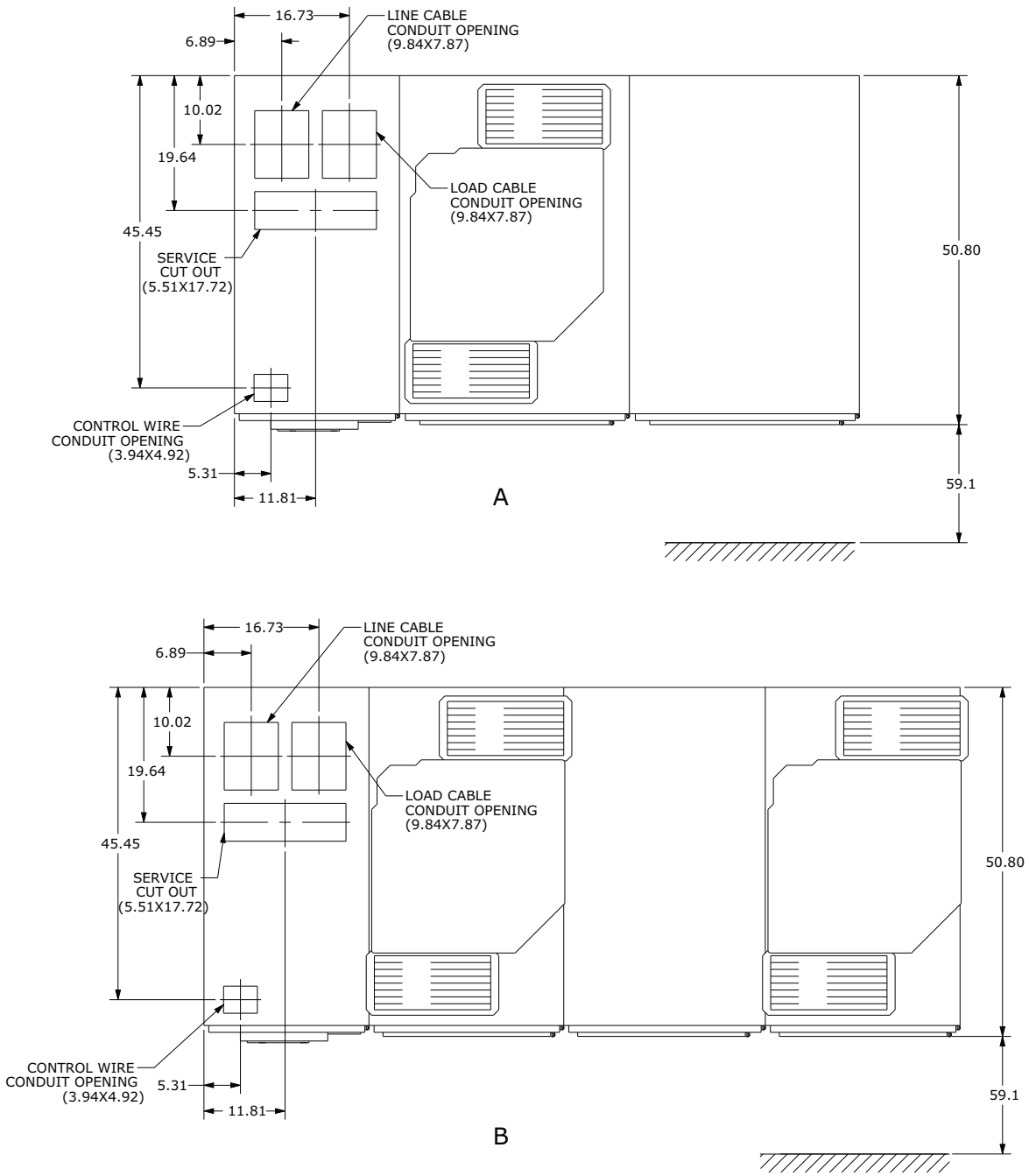
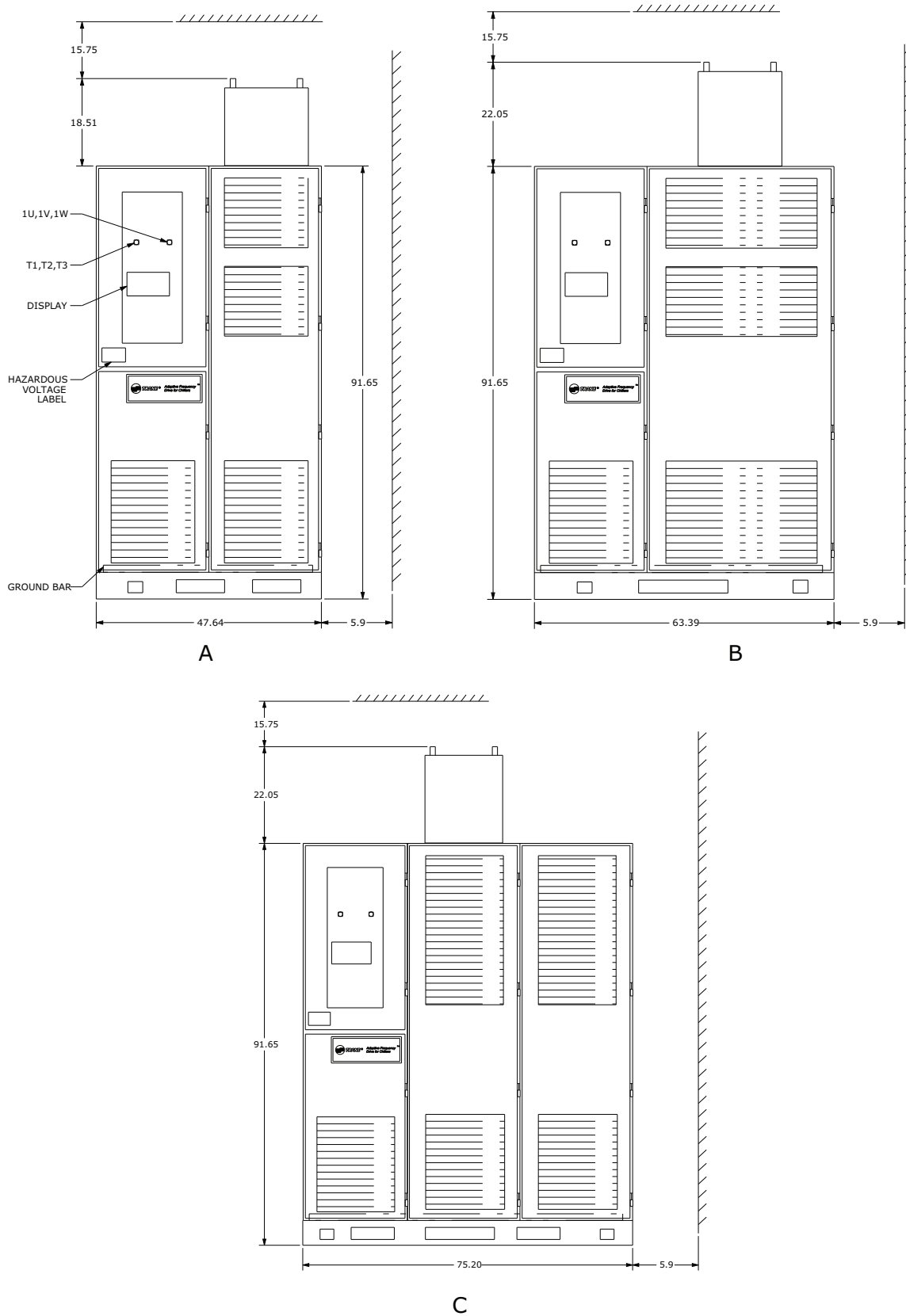


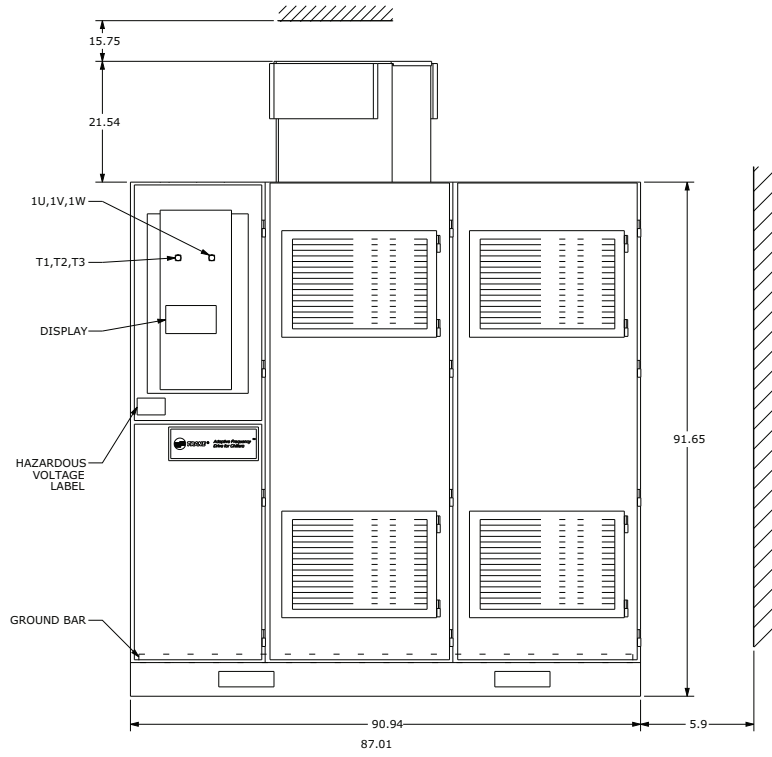
Figure 4. A-Frame: Front view (VFD 2300/3300/4160V), in.



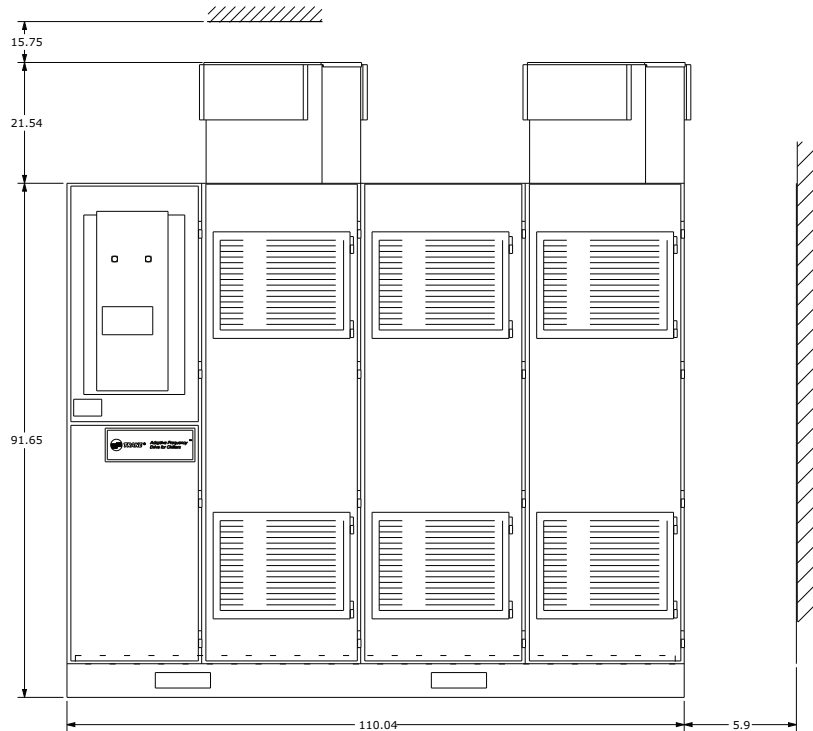


Cabinet

Figure 5. A-Frame: Front view (VFD 660V), in.

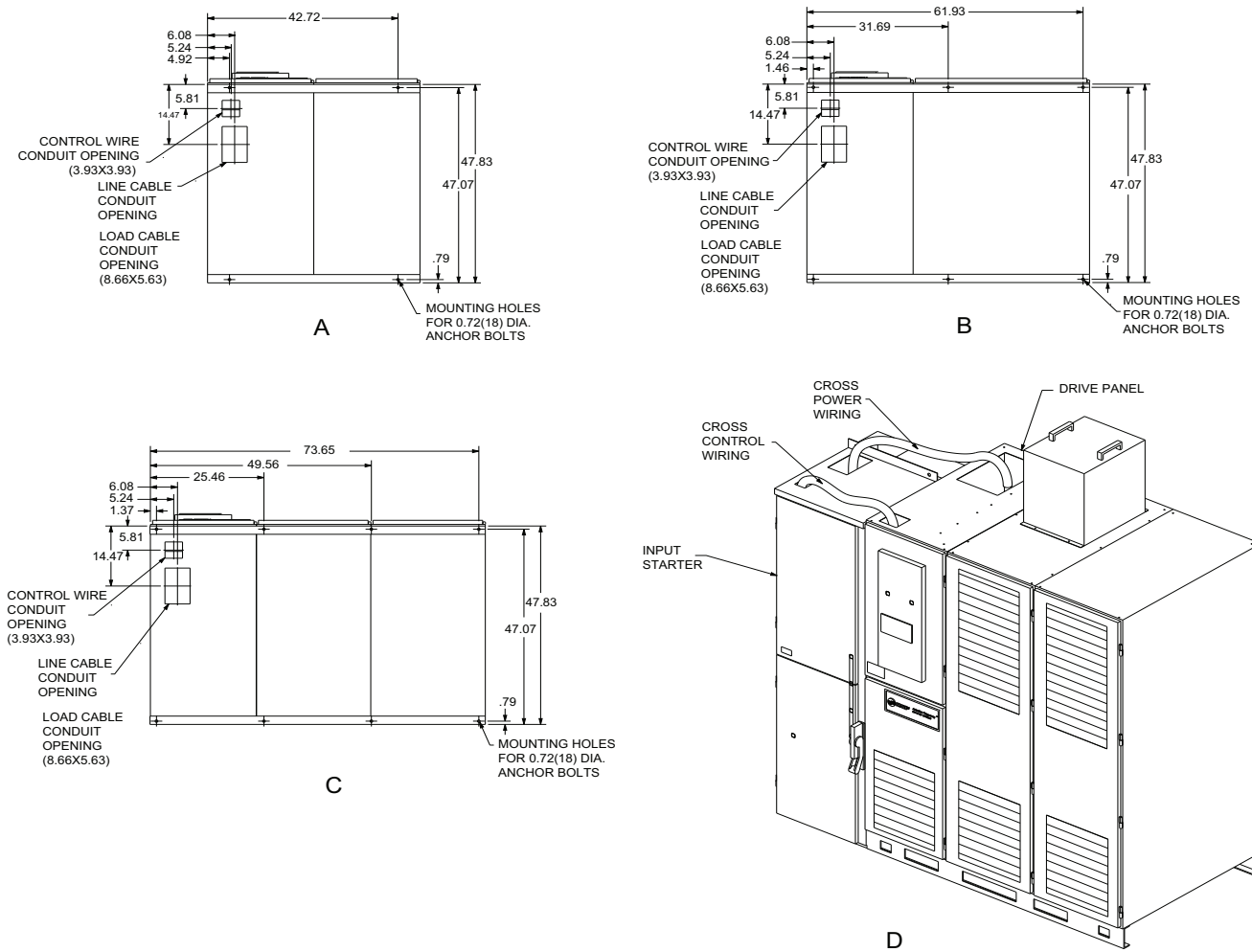


A



B

Figure 6. A-Frame: Bottom view (VFD 2300/3300/4160V), in.



FIELD LAYOUT

NOTES :

- CROSS POWER WIRING - REFER TO FIELD WIRING DIAGRAM. (CONDUIT IS RECOMMENDED).
- CROSS CONTROL WIRING - REFER TO FIELD WIRING DIAGRAM. (CONDUIT IS RECOMMENDED).
- INPUT STARTER - CAN BE PLACED ON RIGHT OR LEFT SIDE OF THE DRIVE.

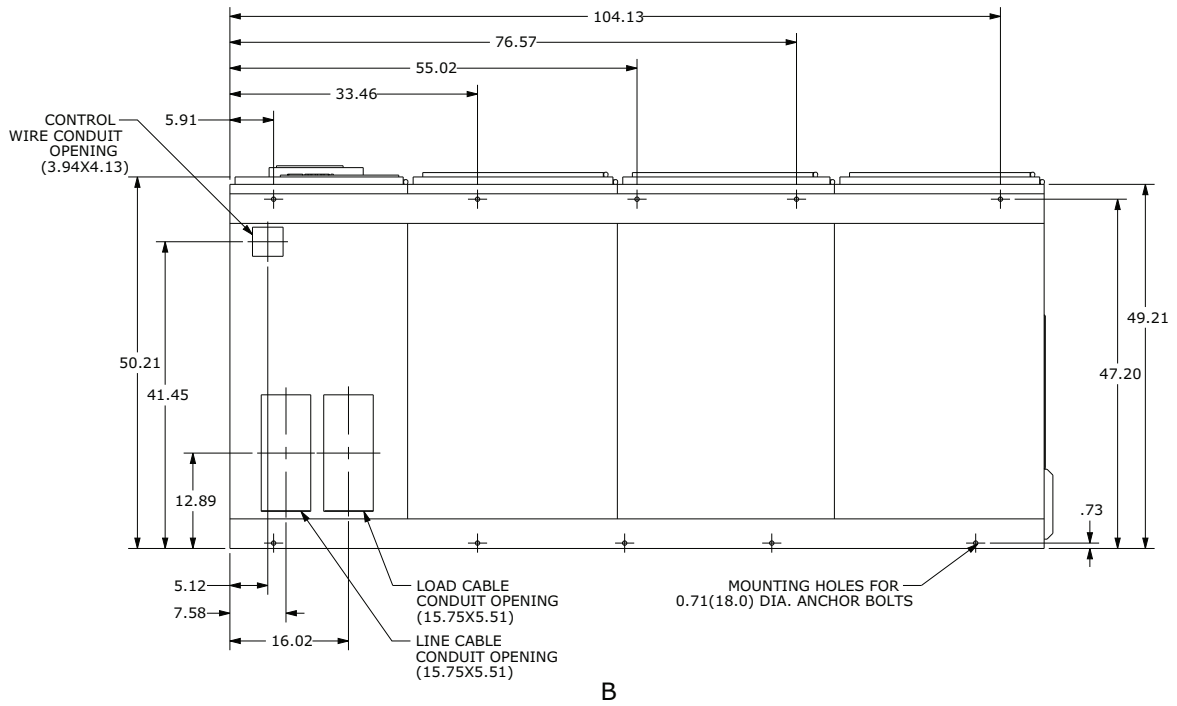
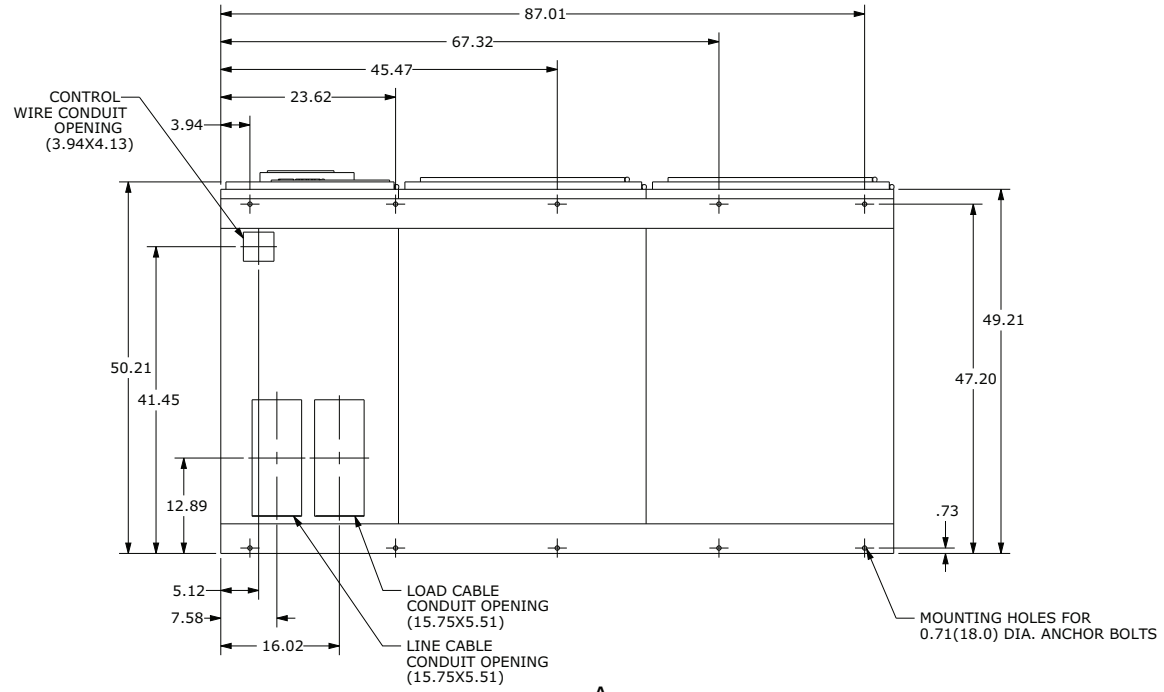
Figure 7. A-Frame: Bottom view (VFD 6600V), in.


Figure 8. A-Frame: Front view (VFD 6600V/160 and 215 Amps), in.

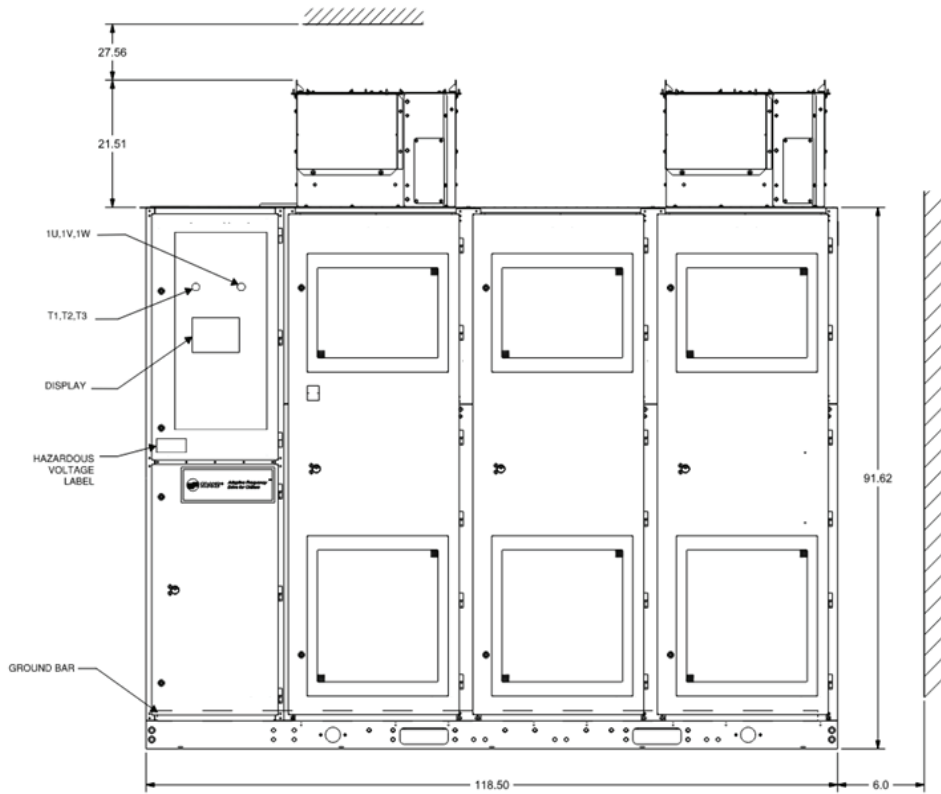


Figure 9. A-Frame: Bottom view (VFD 6600V/160 and 215 Amps), in.

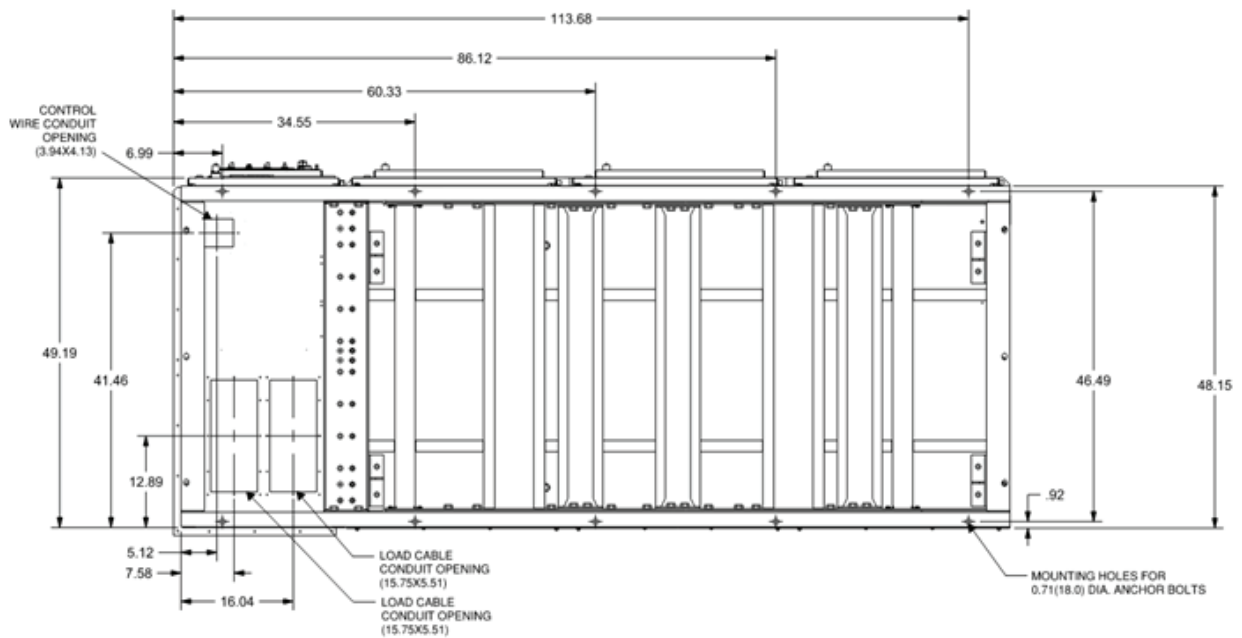
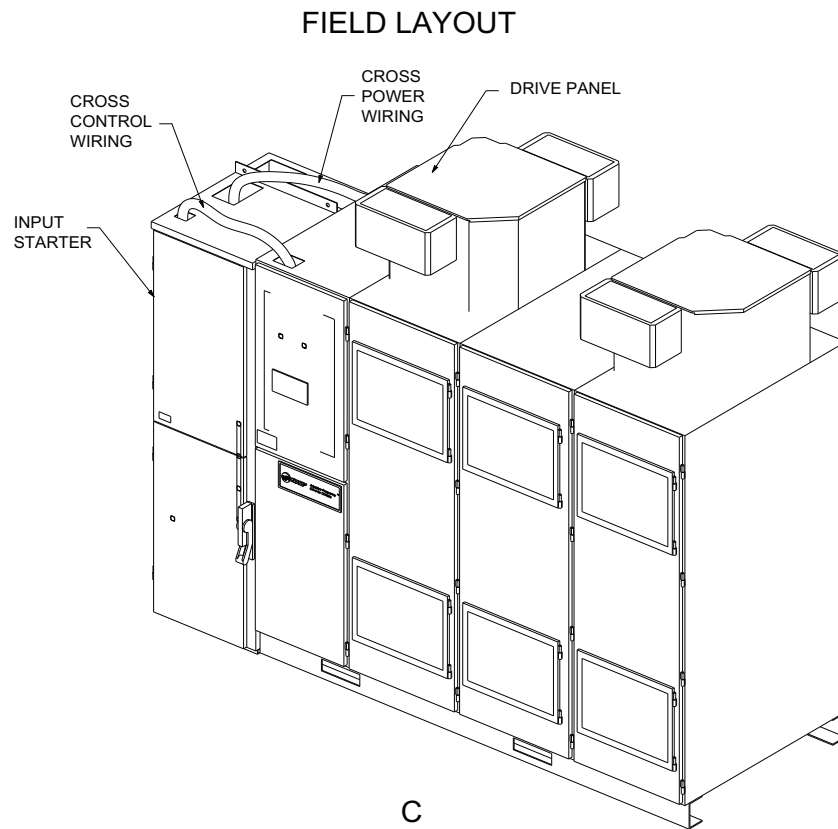


Figure 10. A-Frame: Field layout (VFD 6600V), in.



NOTES :

- CROSS POWER WIRING - REFER TO FIELD WIRING DIAGRAM.
- CROSS CONTROL WIRING - REFER TO FIELD WIRING DIAGRAM.
- INPUT STARTER - CAN BE PLACED ON RIGHT OR LEFT SIDE OF THE DRIVE.

Figure 11. A-Frame: Door-swing requirements, in.

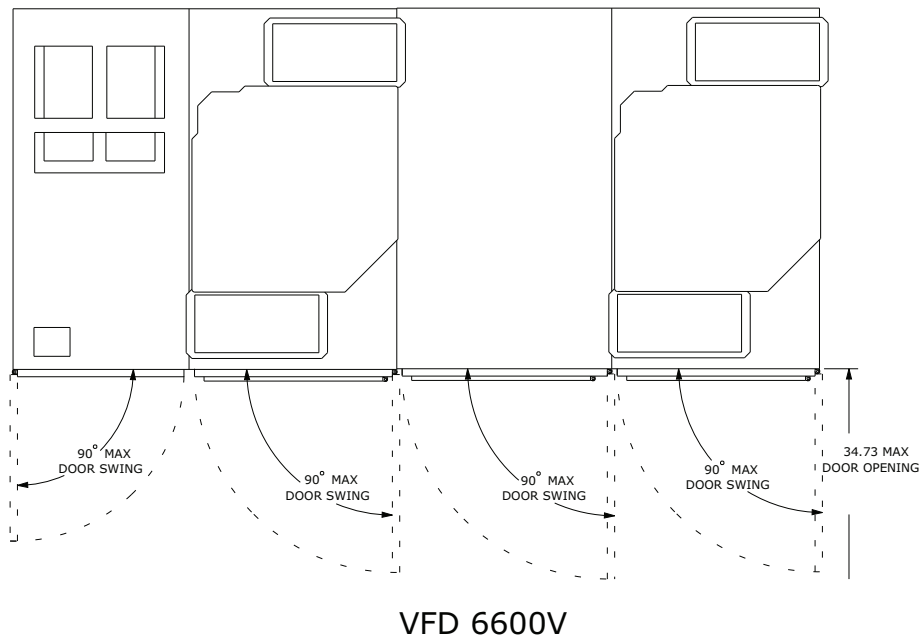
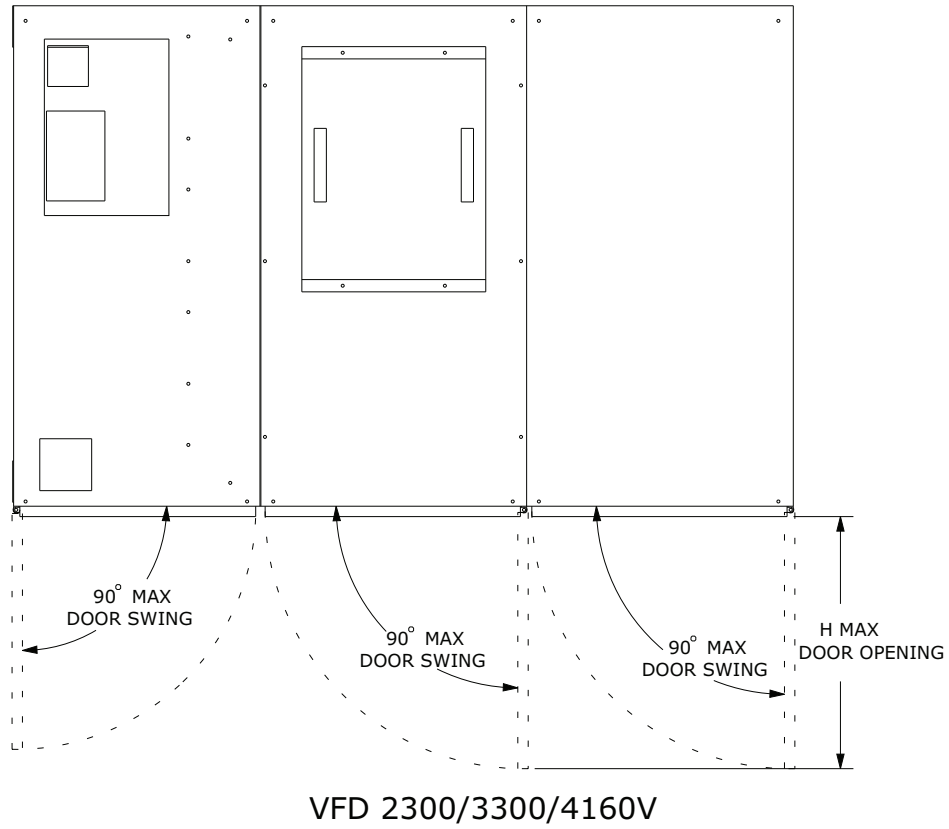


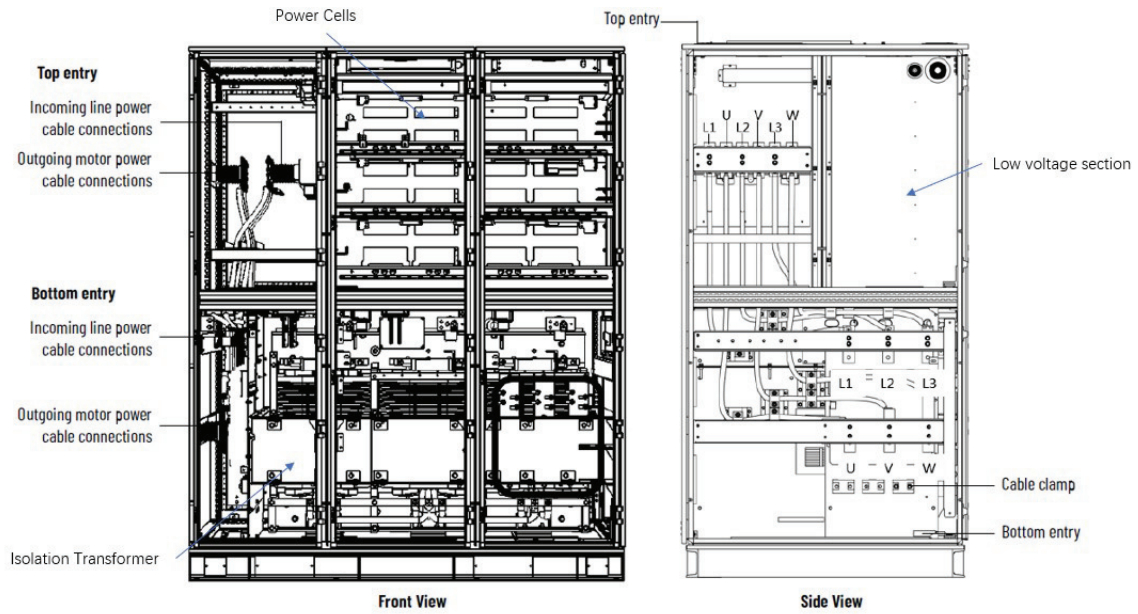
Figure 12. A-Frame: Interior view, major components, in.


Figure 13. B-Frame: Top view, in.

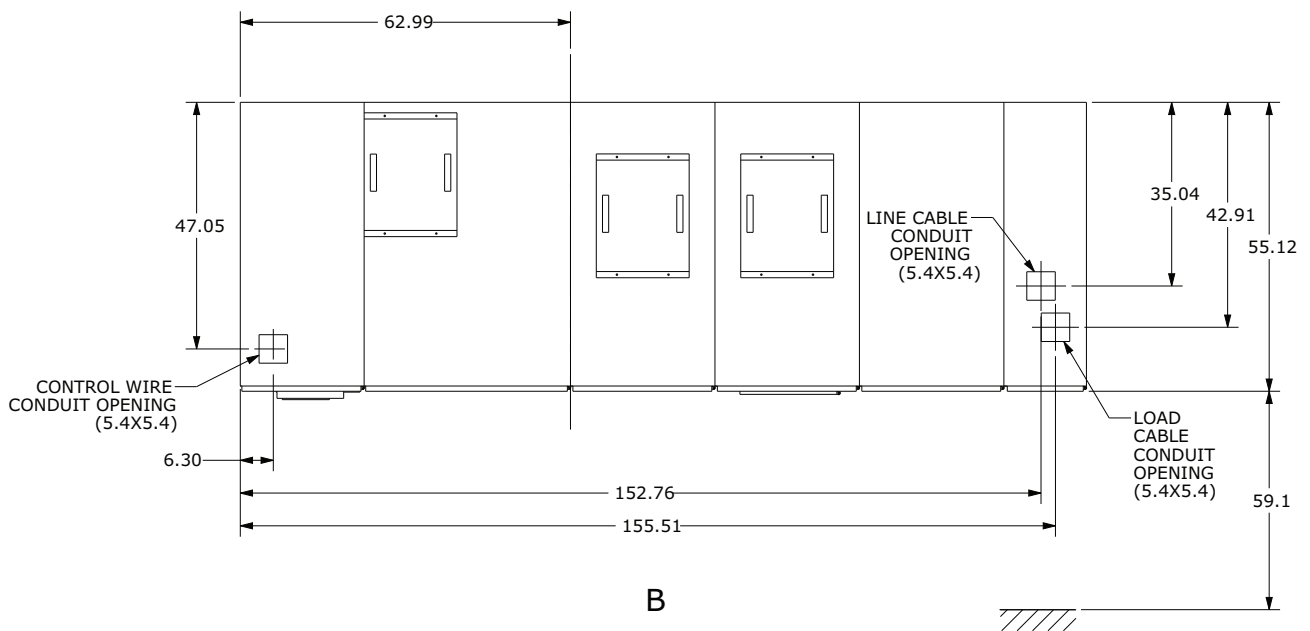
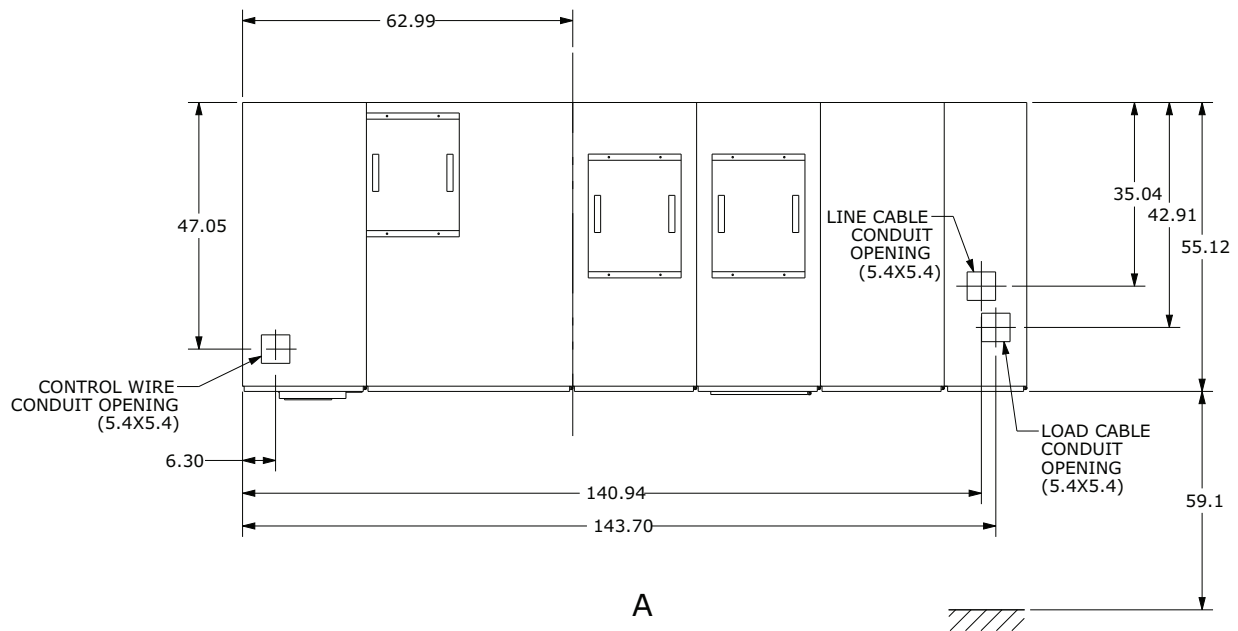


Figure 14. B-Frame: Front view, in.

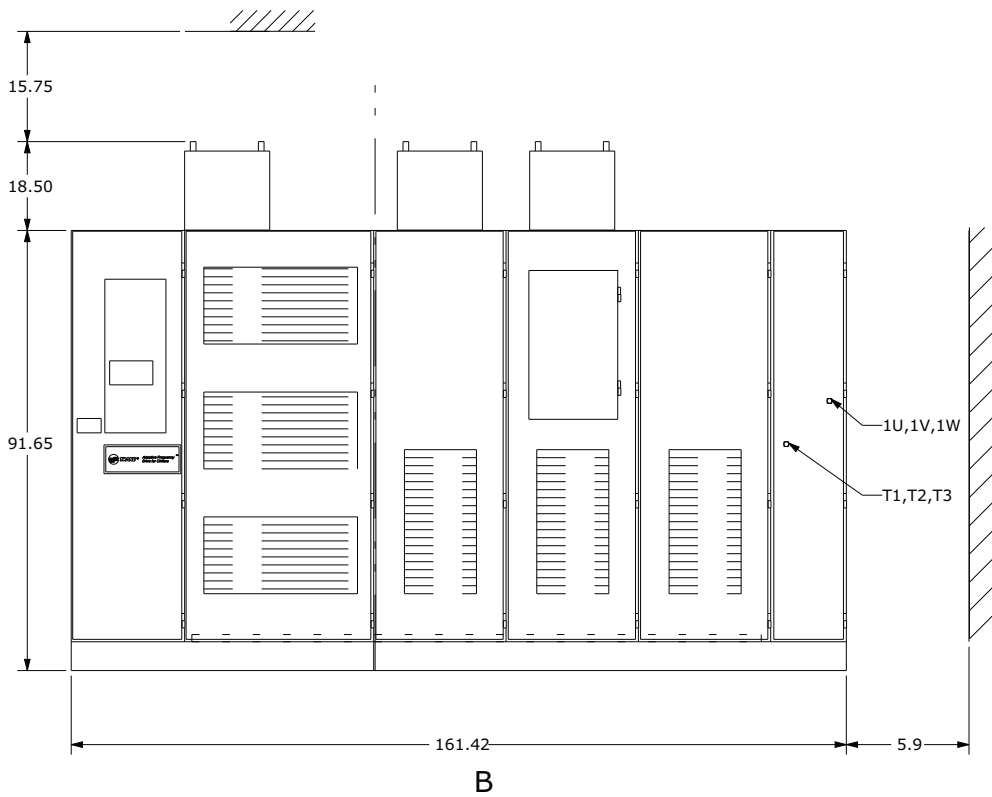
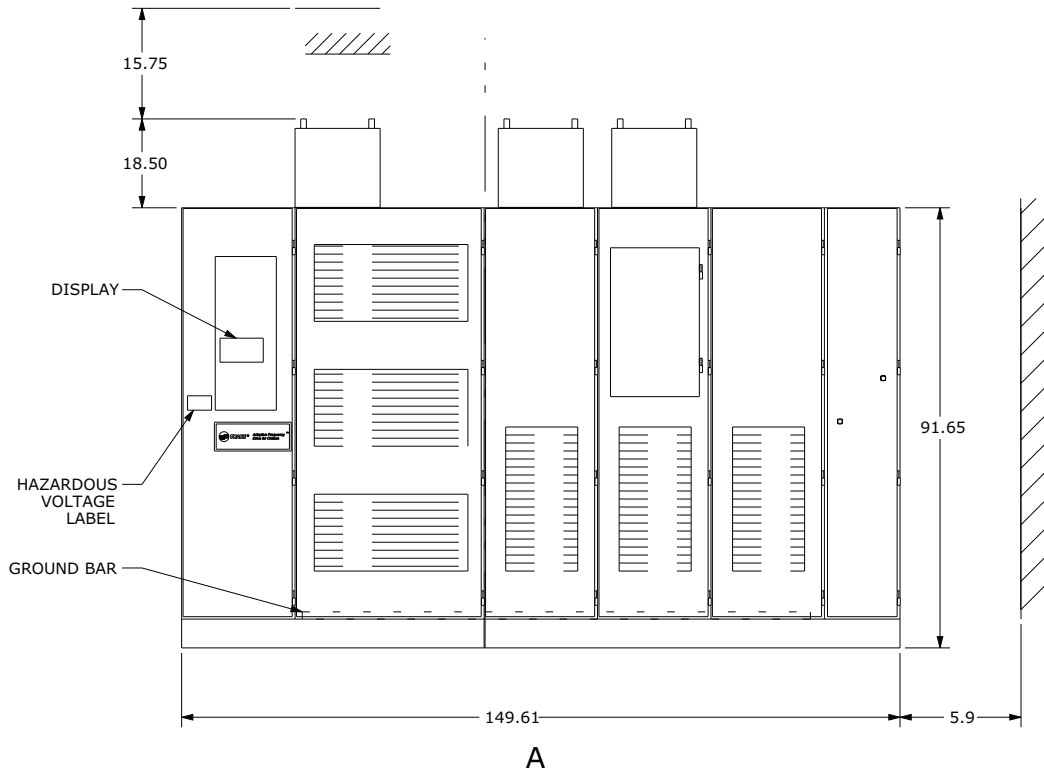


Figure 15. B-Frame: Bottom view, in.

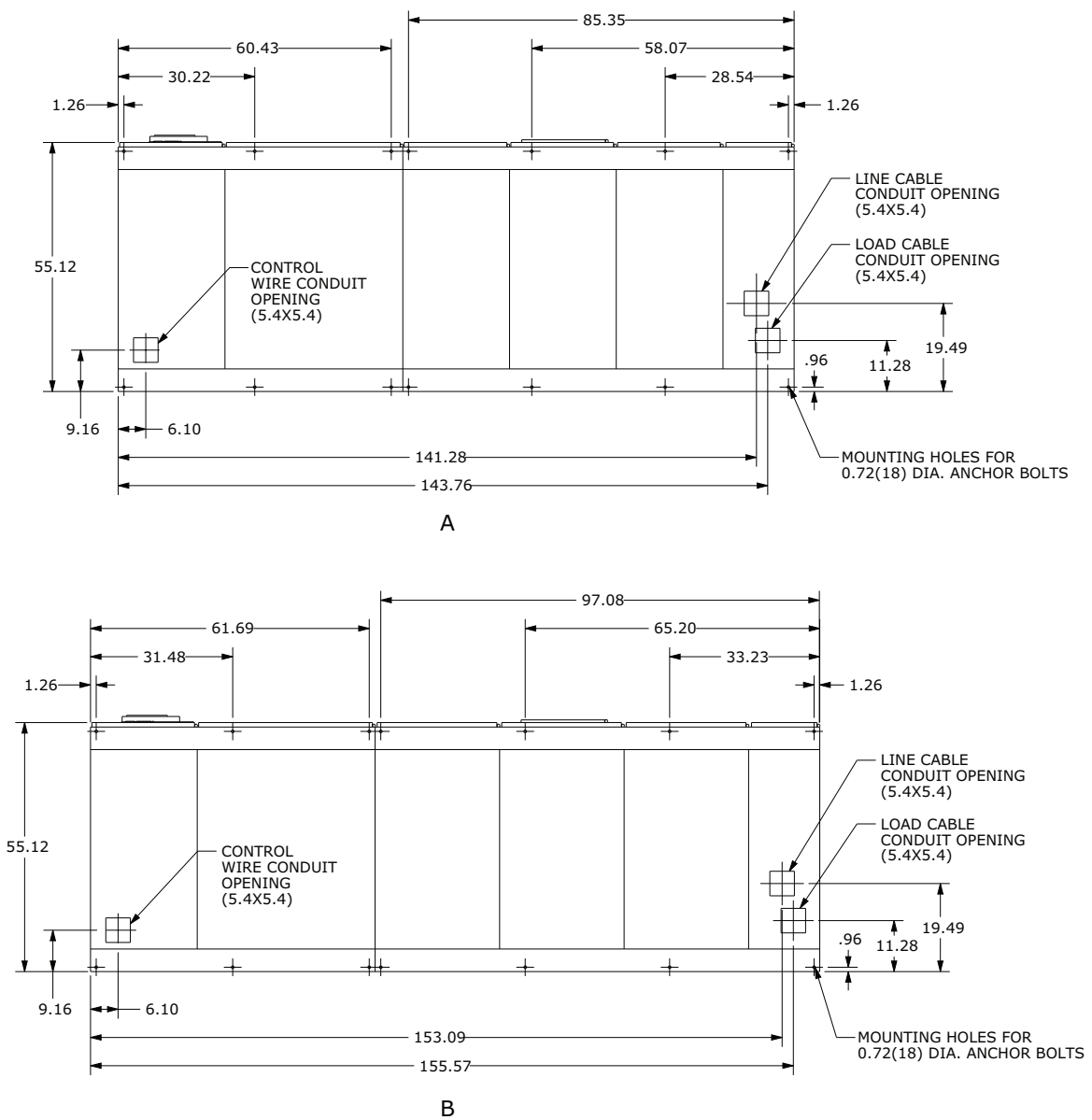


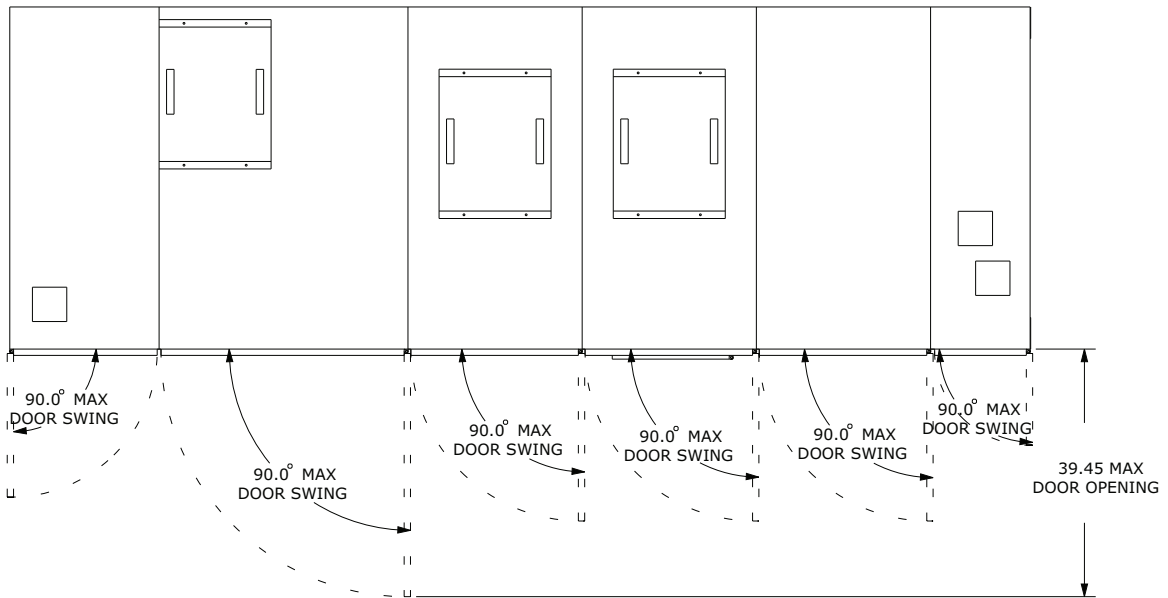
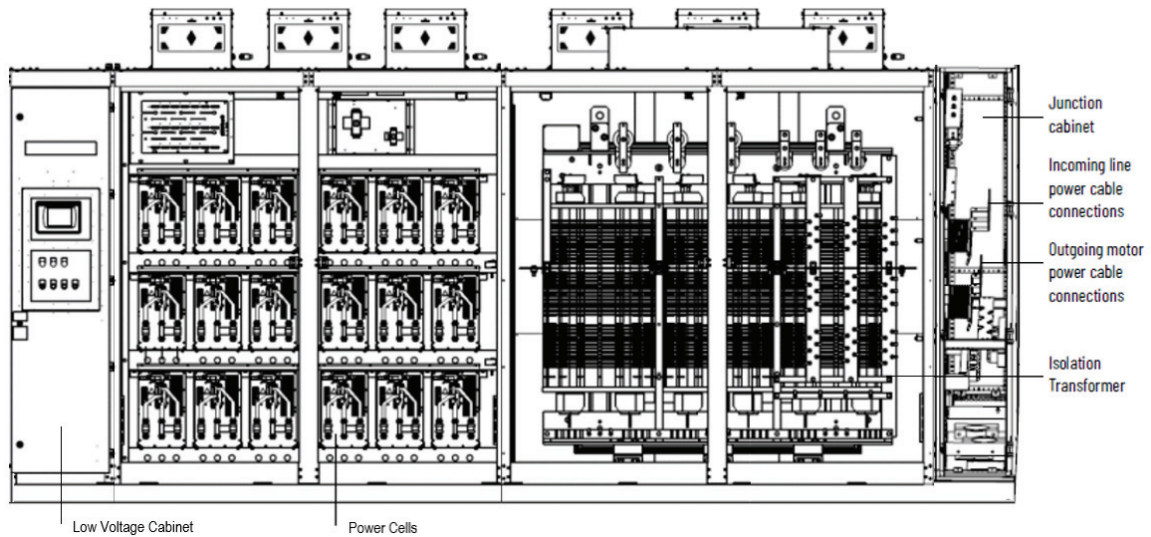
Figure 16. B-Frame: Door-swing requirements, in.

Figure 17. B-Frame: Interior view, major components


Figure 18. Input starter: Top view, in.

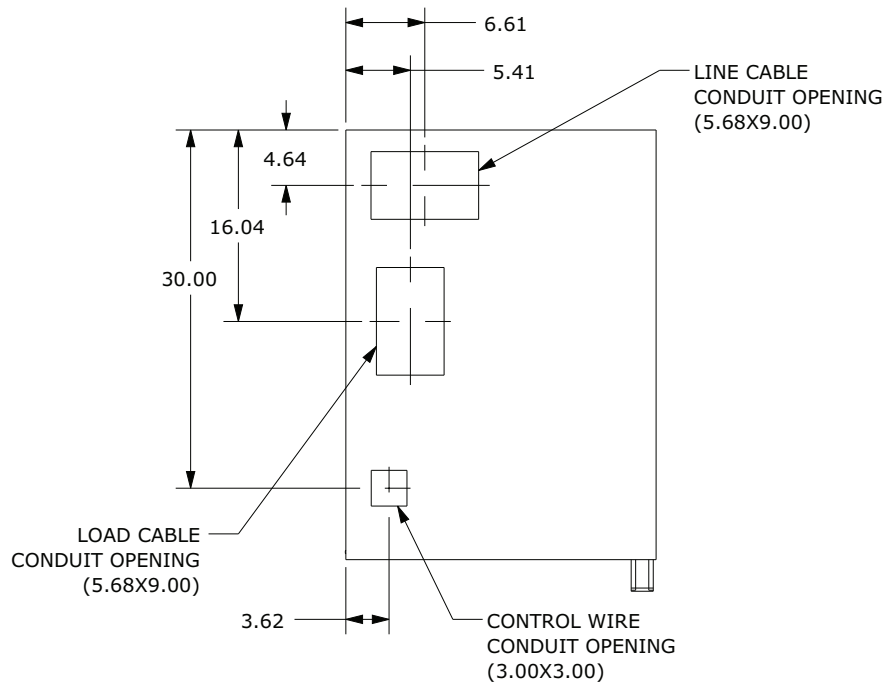


Figure 19. Input starter: Front view, in.

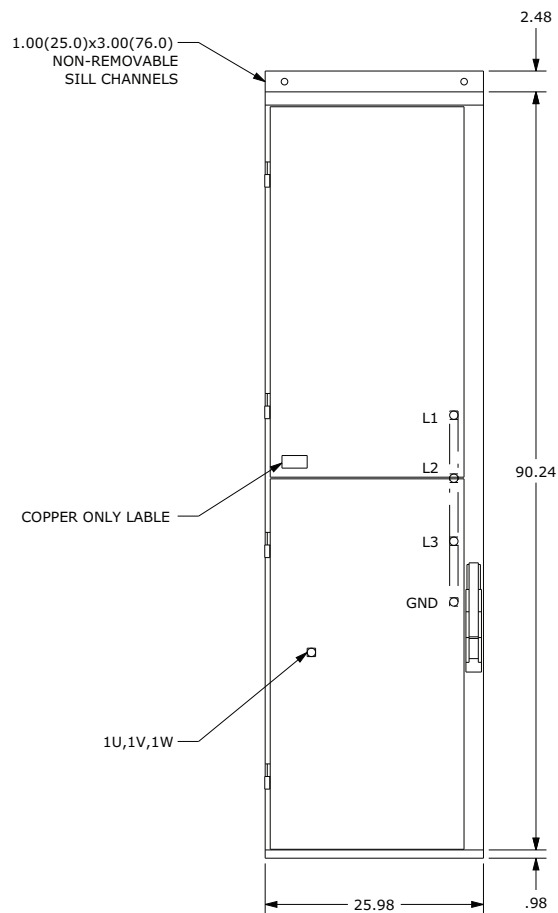


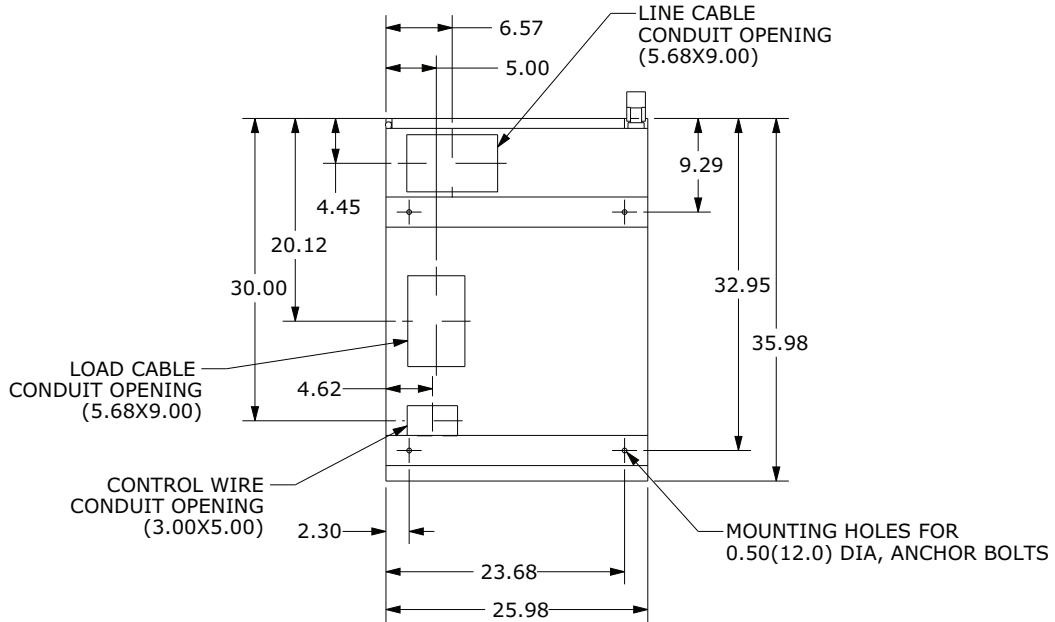
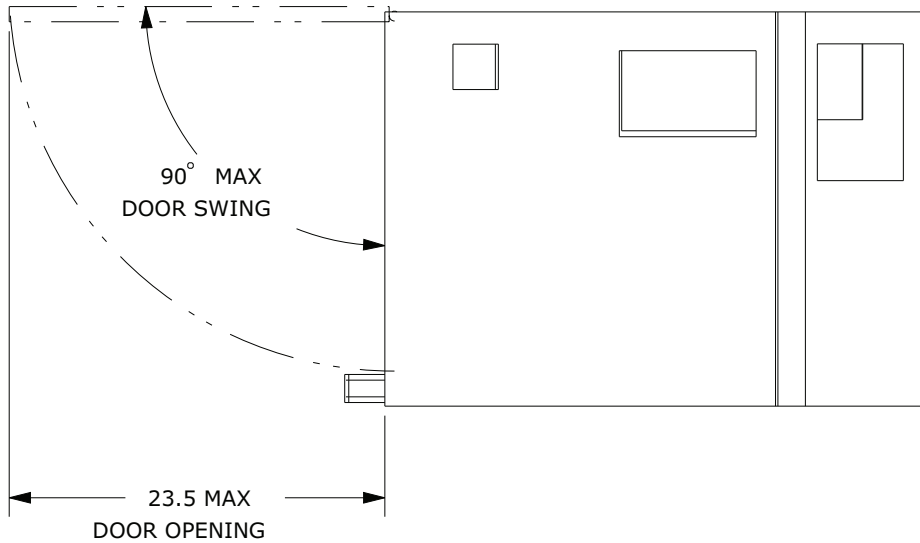
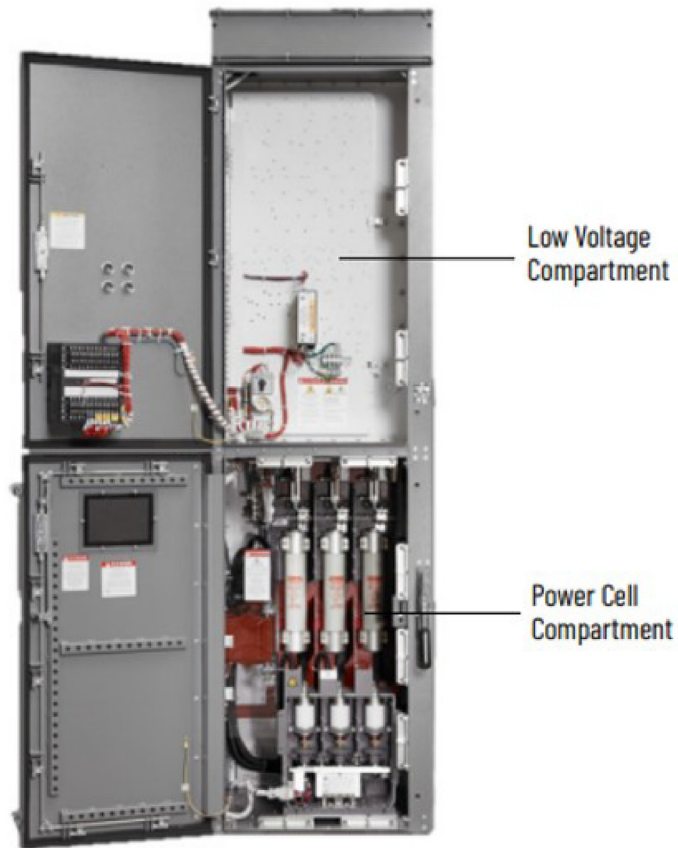
Figure 20. Input starter: Bottom view, in.

Figure 21. Input starter: Door-swing requirements, in.


Figure 22. Input starter: Interior view, major components



Pre-Installation

Receipt Inspection

Immediately upon the drive, inspect the crates for signs of damage. After the crates are offloaded, disassemble the crating and check for possible shipping damage. Use a crowbar or other suitable tool to carefully remove the packaging. Do not insert the tool too far into the packaging or damage to the drive cabinet may occur. Inspect the drive cabinets for physical damage according to the Rockwell Automation Conditions of Sale. Open the doors and inspect the major components for signs of damage.

Figure 23. Crated cabinet



Shipment list

The complete shipment will consist of a number of crates, includes input starter crate, drive panel crate and several crates for fan (depends on fan quantity). For Frame A drive, isolation Transformer and Power Module/LV control will be together in one crate. For Frame B drive, isolation Transformer and Power Module/LV control will be separated in two crates.

The shipment includes the document /hardware box also:

- Testing Reports
- Electrical Drawings (EDs) and Dimensional Drawings (DDs)
- Certifications
- All necessary hardware for mounting lifting angles and fan assemblies, and securing the cabinets together.
- Keys for the lockable cabinet handles.

Overhead Lifting

⚠ WARNING

Improper Lift or Move!

Failure to follow instructions below could result in death or serious injury.

- Use only the lifting and moving methods outlined in this document.
- Do not tilt the drive when lifting or moving. Ensure the drive remains vertical at all times.

⚠ WARNING

Heavy Object!

Failure to follow instructions below could result in unit dropping which could result in death or serious injury, and equipment or property-only damage.

Ensure that all the lifting equipment used is properly rated for the weight of the unit being lifted. Each of the cables (chains or slings), hooks, and shackles used to lift the unit must be capable of supporting the entire weight of the unit. Lifting cables (chains or slings) may not be of the same length. Adjust as necessary for even unit lift.

⚠ WARNING

Improper Unit Lift!

Failure to properly lift unit in a LEVEL position could result in unit dropping and possibly crushing operator/ technician which could result in death or serious injury, and equipment or property-only damage. Test lift unit approximately 24 inches (61 cm) to verify proper center of gravity lift point. To avoid dropping of unit, reposition lifting point if unit is not level.

The preferred method of lifting the cabinets is an overhead crane. If overhead lifting with a crane is not available, use a fork lift with a capacity greater than the cabinet weight. Lift the cabinet using the overhead lifting angles or isolation transformer lifting provisions and suitable spreader bars and rigging attached to the fork lift.

Important: Do not allow the drive to tilt during lifts and/or moves. Drives may contain heavy components that are mounted for vertical shift. Tilting can cause heavy items to shift.

Lift the Power Module/LV Control Cabinet

Depending on the type of drive frame, or lifting angles must be installed before you can lift the cabinet.

Lifting Bars for A-frame Drives (All ratings)

The lifting bars are shipped with the main drive and must be secured before lifting the cabinet.

1. Remove the lifting bars from the skid.
2. Remove the four lifting covers at the bottom of the front and back sides of the drive.
3. Push the lifting bars through the lifting holes at the bottom of the drive. Make sure the locking hole at the both ends of each lifting bar are visible from the front and back sides of the drive. Refer to [Figure 24](#).
4. Secure the lifting bars with M8 bolts, washers, and lock washers. Then attach a shackle to each end of the lifting bars. Refer to [Figure 25](#).

Figure 24. Install lifting bars from A-frame drives (all ratings)

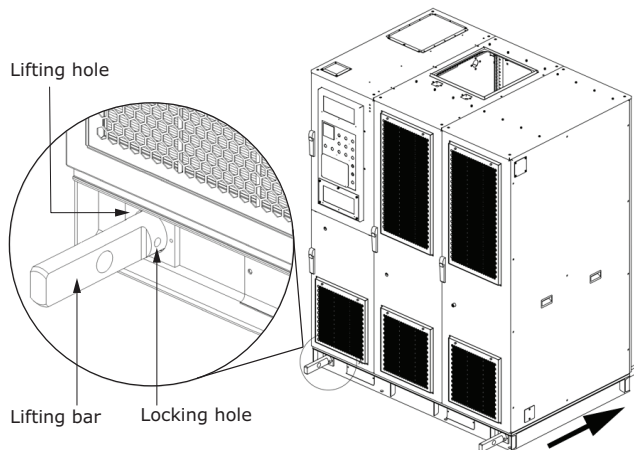
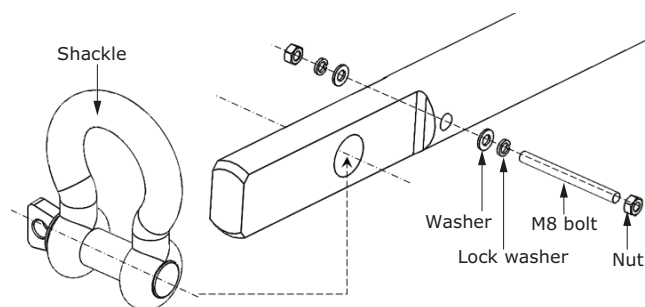


Figure 25. Install shackles to the lifting bar

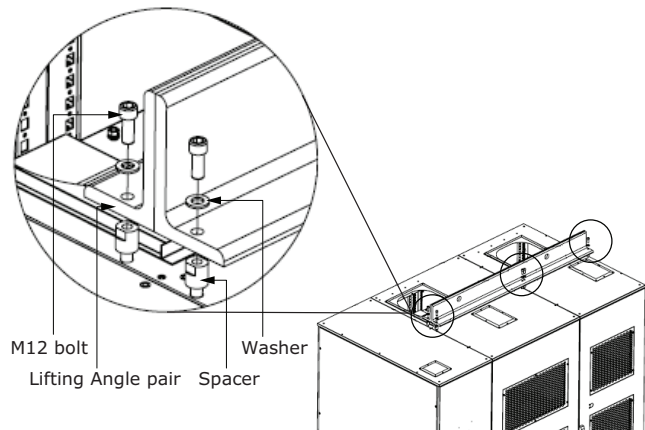


Lifting Angles for B-frame Drives

The lifting angles hold the Power Module/LV Control cabinets together to prevent separation and damage while riggers move the drive to the final installation area.

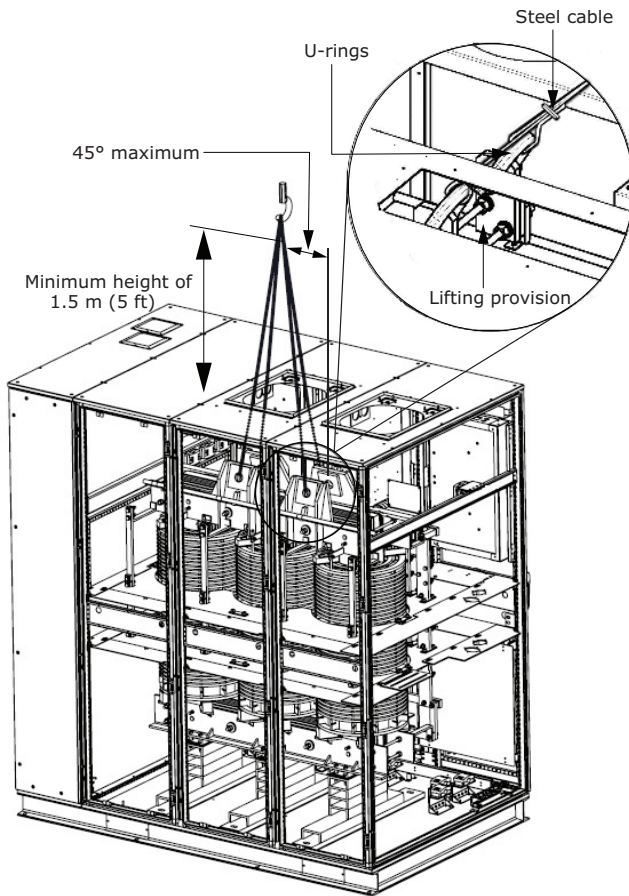
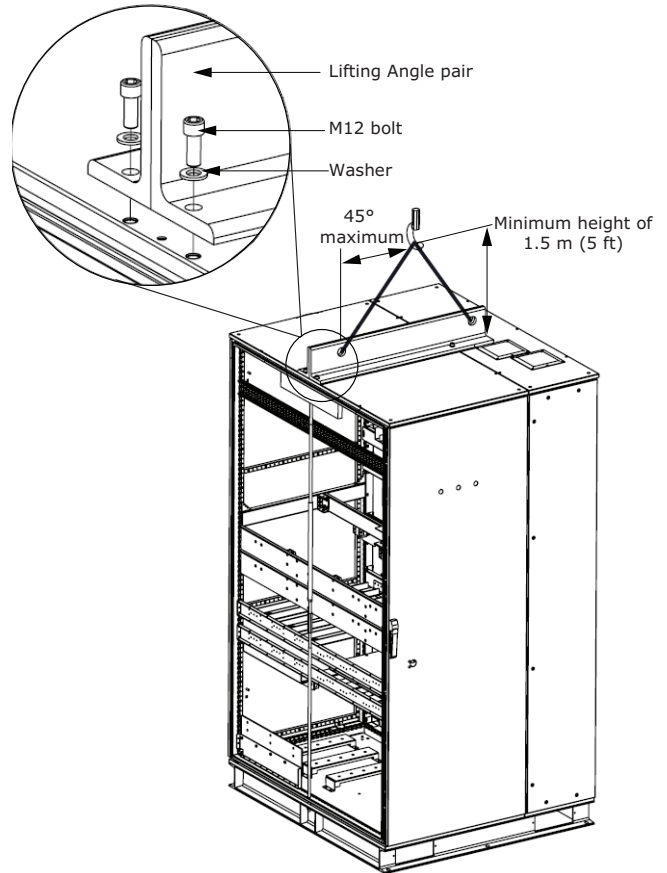
1. Remove the lifting angles from the skid.
2. Align and secure the lifting angles in four places as shown in below figure.

Figure 26. Install fasteners from the lifting angles to the drive in four places per cabinet



Lift the Isolation Transformer Cabinet (for B-frame Drives Only)

1. Unfasten and remove the middle top plate on top of the cabinet, and retain middle top plate and hardware. The configurations have two to five top-mounted main cooling fans in the isolation transformer cabinet.
2. Attach the select cable to the U-ring attachments [Figure 27](#), ensuring the cables pass freely through one or two fan openings of the cabinet and that they do not contact the edge of the fan opening.
3. Attach the U-ring attachments to the lifting provisions on the isolation transformer.

Figure 27. Overhead lifting (isolation transformer cabinet)

Figure 28. Overhead lifting (starting/junction cabinet)


Lift Input Starter

The lifting angles hold the starting/junction cabinet together to prevent separation and damage while riggers move the drive to the final installation area.

The lifting angles are shipped with the starting/junction cabinet and must be secured before lifting the cabinet.

1. Remove the lifting angles from the skid.
2. Remove the attachment hardware that is pre-installed in the mounting holes in the top plate of the cabinet before shipment.
3. Align and secure the lifting angles in four places as shown in below figure.
4. Re-install the hardware (M12 x 2) and the pre-installed attachment hardware (M6) in the mounting holes (to seal the holes) on the top of the drive.

Storage

NOTICE

Equipment Damage!

Failure to follow storage recommendations could result in equipment-only damage. Read this section carefully and follow all recommendations for drive storage.

If the storage of the equipment is longer than one year, it is recommended to power up once a year. If equipment containing electrolytic capacitors (like power supplies, power cells, etc.) is stored (unpowered) under normal storage temperatures and conditions, it can be kept up to 15 years.

Storage the drive in a dry, clean, and cool area.

The storage temperature must be maintained between -40...+70 °C (-40...+158 °F). This temperature rating applies only to the drive, it does not include the UPS (Uninterruptible Power Supply). If the storage temperature fluctuates significantly or if the relative humidity exceeds 95%, use heating and moisture protection devices to prevent condensation.

Store the drive in a conditioned building with adequate air circulation. Do not store the drive outdoors.



Mechanical Installation

Install Drive panel

Connect Shipping Splits

The standard A-frame for PowerFlex 6000T drives comes fully assembled and does not require any shipping splits

The B-frame for PowerFlex 6000T drives are shipped in two sections, the Isolation Transformer Cabinet and Power Module/LV Control Cabinet. These two cabinets must be connected after located in its final position. The cabinets are connected together in 8 or 10 places (depending on the drive

Figure 29. Align the cabinets, B-frame (6 kV shown)

rating), half along the front edge of the cabinet and half along the rear edge of the cabinet. Access to the interior of the cabinet is required to make these connections. Access for the front connections requires only opening the doors. Access for the rear connections requires removing the back plates of the cabinet.

1. Arrange the sections as directed in the Dimensional Drawings and move the sections together.
2. Align the cabinet side sheets together at the holes for the hardware, refer to below figure.

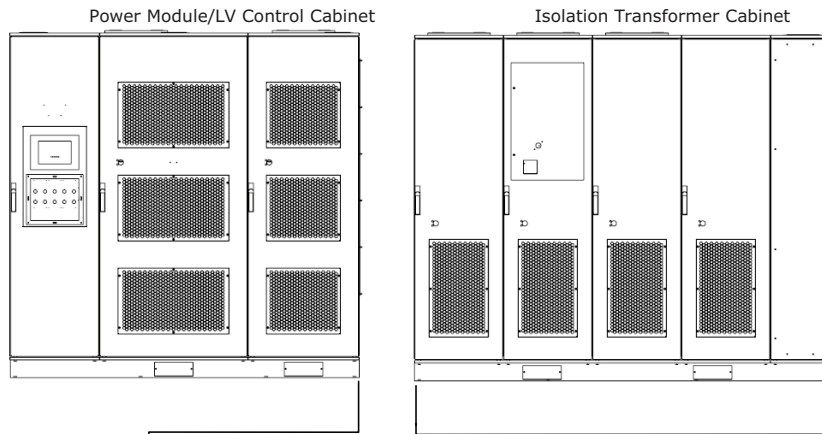
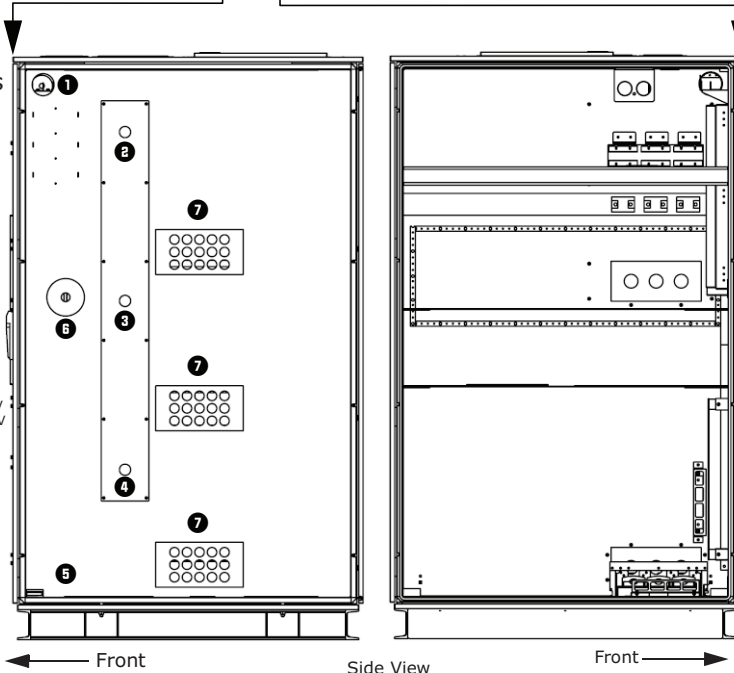


Table 1 - Sidesheet Openings

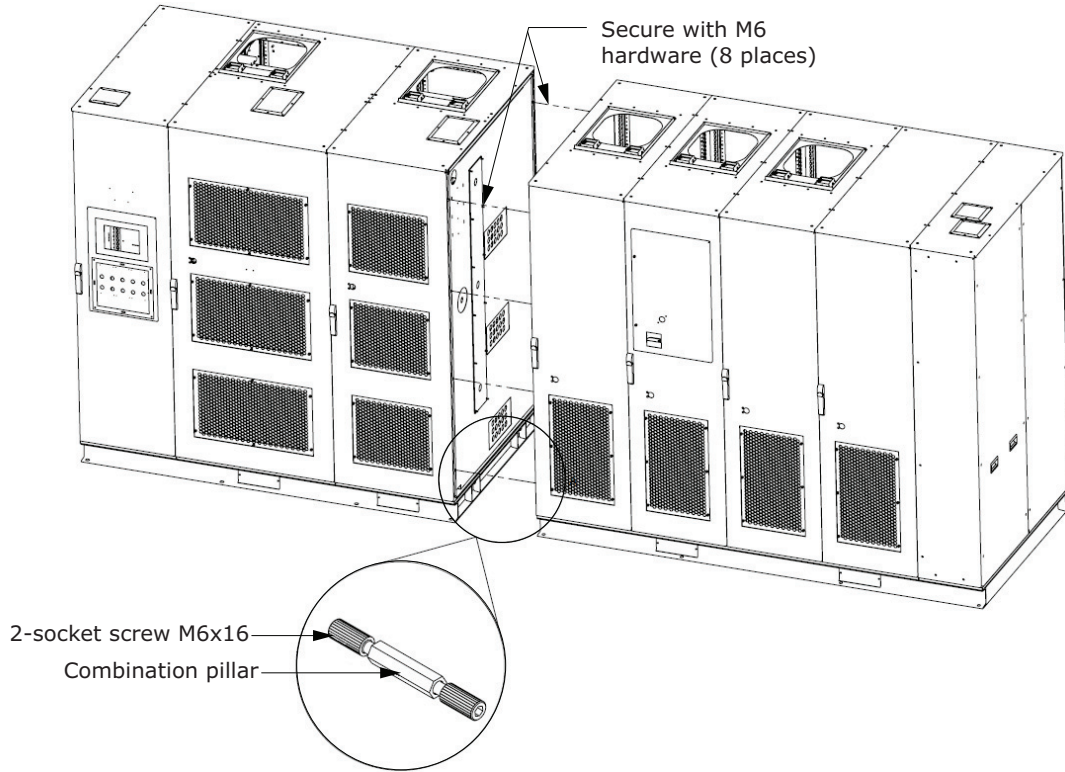
1	Front Wireway
2	U Phase Motor Cable
3	V Phase Motor Cable
4	W Phase Motor Cable
5	Ground Bus Connection
6	Voltage Sensing Board Cables
7	Isolation Transformer Cables Secondary ⁽¹⁾⁽²⁾

- (1) The number of Isolation Transformer secondary cables is dependent on motor voltage class.
- 9 cables per motor phase (27 total) for 3/3.3 kV
 - 12 cables per motor phase (36 total) for 4.16 kV
 - 15 cables per motor phase (45 total) for 6 kV
 - 18 cables per motor phase (54 total) of 6.6 kV
 - 24 cables per motor phase (72 total) for 10 kV
 - 27 cables per motor phase (81 total) for 11 kV
- (2) 6/6.6 kV configurations only require 18 cable hole locations per phase. Extra cable hole locations allow for added installation flexibility.



3. Secure the cabinets together using M6 and M8 hardware.
Open the doors to access front edge joining holes (four or five places).

Figure 30. Secure the cabinets, B-frame



Affix Cabinets to Floor

⚠ WARNING

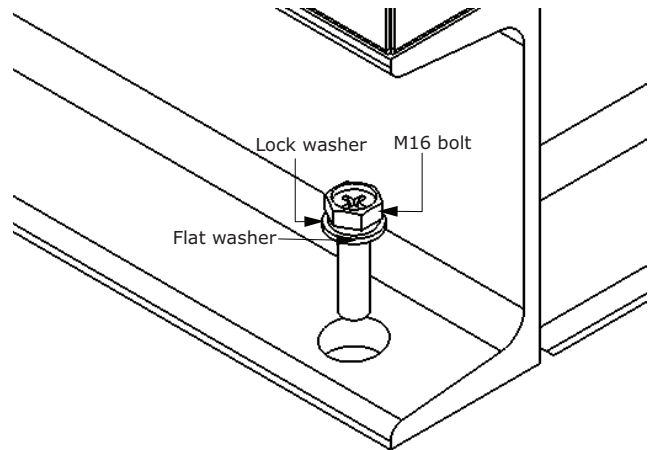
Drive Mounting Instructions!

Failure to correctly anchor the cabinet could result in death or serious injury and equipment damage. Refer to Rockwell's technical drawings and installation manual for drive mounting instructions. Contact the area Rockwell Automation sales office if you do not have these documents.

Typical floor drawings show minimum clearance distance, conduit openings, and mounting holes for anchor bolts, as shown in below [Figure 6, p. 21](#), [Figure 8, p. 23](#) and [Figure 15, p. 29](#).

Secure the cabinet to the channel steel base using M12 bolt (recommended), lock washer, two flat washers, and a nut as shown in [Figure 31](#).

Figure 31. Bolt cabinet to steel base, B-frame



Optional: The cabinet can also be welded to the steel base once it is securely bolted, if desired.

Each weld location should be 3.9 in. (100 mm) for every 39.4 in. (1000 mm). See Mounting Requirements in the PowerFlex 6000T Drives Shipping and Handling Manual, publication 6000-PC100 for further information on the steel base and desired trench and mounting customer-specifications.

Install Input Starter

⚠ WARNING

Hazardous Voltage!

Failure to disconnect power before servicing could result in death or serious injury. Disconnect all electric power, including remote disconnects before servicing. Follow proper lockout/tagout procedures to ensure the power can not be inadvertently energized. Verify that no power is present with a voltmeter.

Anchoring

Input starter cabinet is shipped in separating crate. Place the cabinet on the right of drive panel.

The floor must be flat and level. Use four M12 (0.5 in.) floor mounting bolts to securely fasten the controller to the mounting surface. Refer [Figure 20, p. 32](#) for the location of the mounting holes in the cabinet.

Front Access - Top Incoming Line Cables

1. Complete the Power Lockout Procedures for both medium voltage power cells and the power bus.
2. Open the low voltage cell door.
3. Open the medium voltage cell doors.
4. Remove the two self-tapping screws from the low voltage panel if installed. (Installed for shipping purposes - refer to below figure.)
5. Use a flat head screwdriver and turn both of the 1/4-turn fasteners 180 degree in a counterclockwise direction.

Figure 32. Low voltage panel

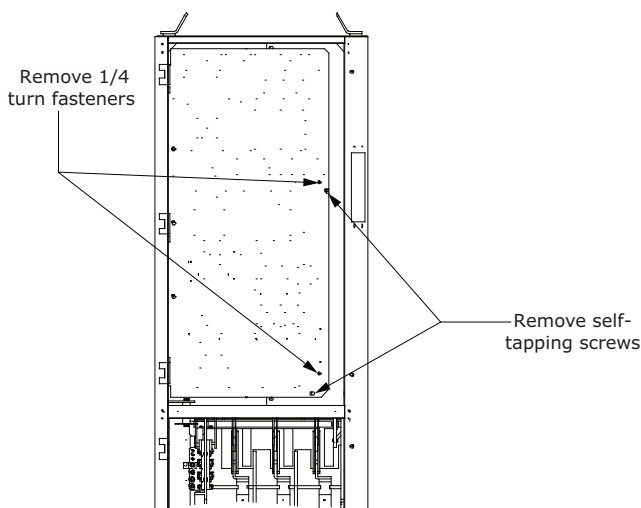
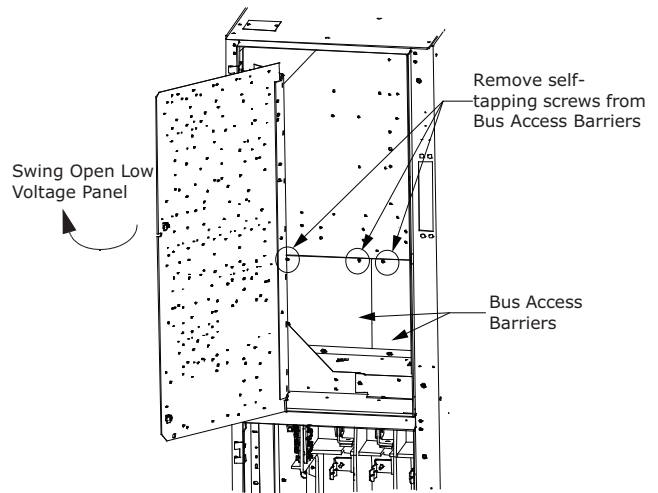


Figure 33. Access to power bus with low voltage panel rotated

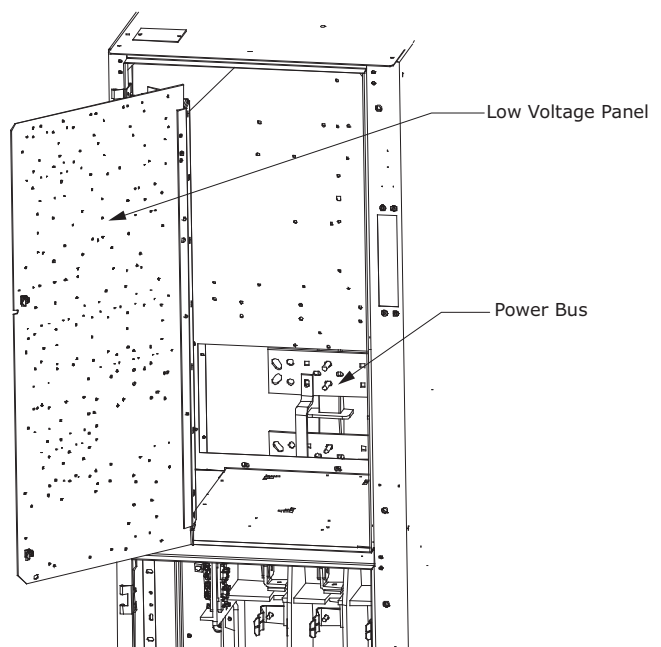


6. Pull on right-hand side of low voltage panel. Swing low voltage panel to the front and left of cabinet. (Refer to above figure).

Note: The power cell door must be in a fully opened position prior to rotating the low voltage panel.

7. Locate the removable bus access barrier (2).
8. Remove retaining screws from removable bus access barriers to expose incoming cable connections to main bus. Refer to below figure.
9. Install incoming line cables to power bus.
10. Reverse procedure after cables have been installed.

Figure 34. Power bus with barrier removed

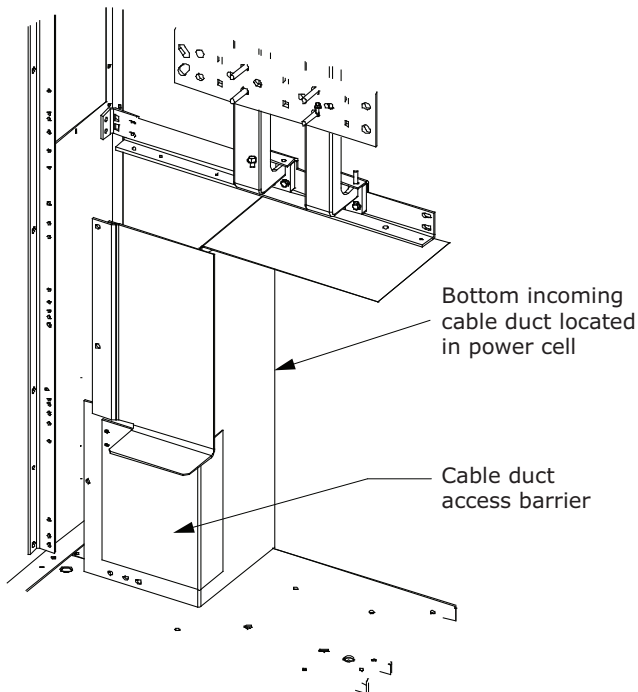


Mechanical Installation

Front Access - Bottom Incoming Cables

1. Open the power cell door.
2. Locate incoming cable duct at rear left-hand side of power cell, refer to below figure.
3. Route self-tapping screws from the cable duct access barriers. Remove barriers.
4. Route and install incoming line cables to power bus.
5. Reverse procedure after cables have been installed.

Figure 35. Access to bottom incoming line cables



Load Cable Connections

1. Complete the Power Lockout procedure.
2. Remove the appropriate cable conduit opening plate(s) from the cabinet (refer to [Figure 18, p. 31](#), [Figure 20, p. 32](#), [Figure 36, p. 40](#) and [Figure 37, p. 40](#)). The plate may be punched or cut to mount conduit.
3. Load cables for the power cell should be routed before control cables. Pull the cables into the cabinet through the appropriate opening (refer to [Figure 18, p. 31](#), [Figure 20, p. 32](#), [Figure 36, p. 40](#) and [Figure 37, p. 40](#)).
4. Remove current transformer barriers.
5. Connect the cables to the current transformers and tighten the connections to 65 Nm (48 lb.ft).
6. Connect cable shields (if present) to the ground lug
7. Reinstall the current transformer barrier and reassemble the cabinet

Figure 36. Access to load cable conduit openings (bottom entry)

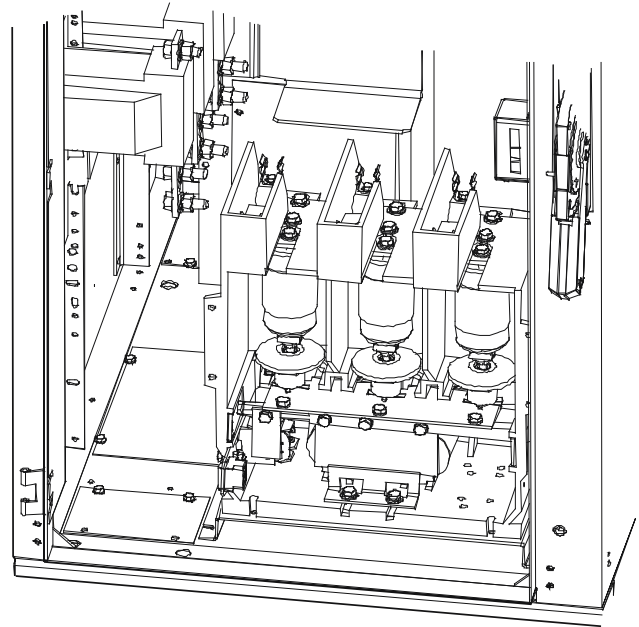
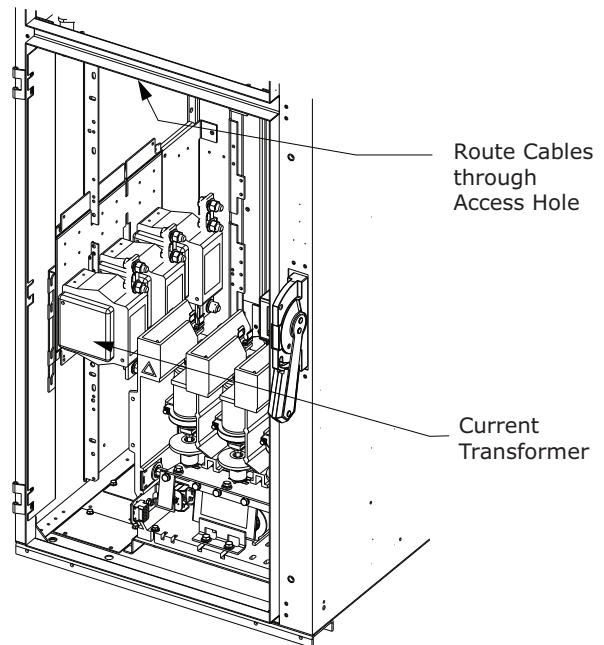


Figure 37. Routing of load cables (top exit shown)



Install Main Cooling Fans

Main cooling fans are shipped in separate crates. The fans are shipped assembled in the fan housing, but must be installed after siting the drive.

1. Place the fan housing on the top plate of the drive, making sure that the socket is on the same side as the aviation plug.

2. Secure the fan housing using M6 hardware (six places).
3. Connect the aviation plug on top of the cabinet with the socket on the fan housing.

Figure 38. Main cooling fan housing, B-frame and A-frame (2.4...4.16 kV)

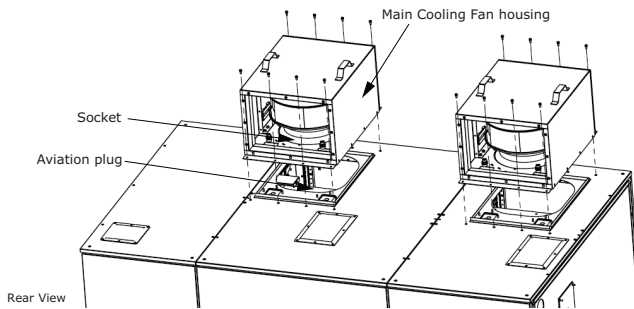
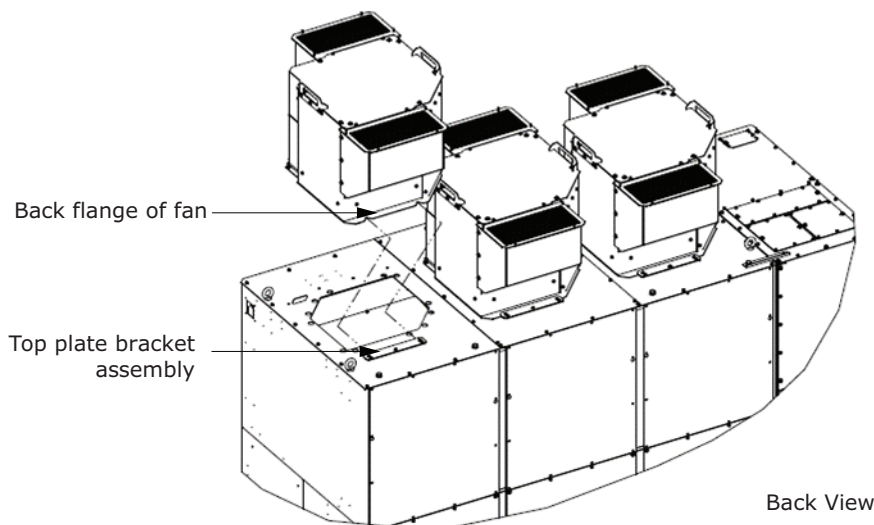
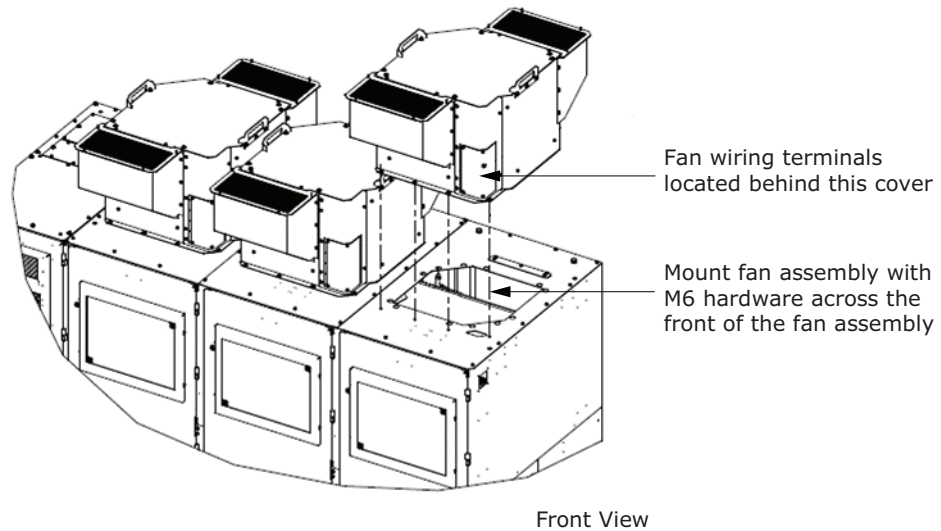


Figure 39. Main cooling fan housing, A-frame (6...6.6 kV)

Install the cooling fan for A-frame drives (6.6 kV)

To install the cooling fan for A-frame 6...6.6 kV drives, follow these instructions.

1. Place the fan housing on the top plate of the drive and slide the fan housing back. Verify that the back flange of the fan housing slides under the top plate fan bracket assembly.
2. Secure the fan housing using M6 hardware across the front of the fan assembly.
3. Connect fan wiring to fan terminals located behind the cover on the front of the fan housing.





Wiring

Input Power, Input Starter to Drive Panel, Drive to Motor, and Control Wiring

This section explains the required field wiring for each chiller motor and drive.

Note: For Duplex™ chillers, this will be required for both Circuit 1 and Circuit 2.

For AWG/MCM equivalents in mm², refer to Table 4:

Table 4. Wire sizing reference

AWG/MCM	mm ² equivalent
22	0.32
21	0.35
20	0.5
18	0.75
17	1.0
16	1.5
14	2.5
12	4
10	6
8	10
6	16
4	25
2 or 1	35
1/0	50
2/0	70
2/0 or 3/0	95
4/0 or 250	120
300	150
350 or 400	185
450 or 500	240

Note: AWG = American Wire Gauge

Important: Customers are responsible for all field wiring in compliance with local, national, and/or international codes.

Installing Input Power Wiring and Standard Cabinet

Use the following steps to connect AC input power to the cabinet:

⚠ WARNING

Hazardous Voltage w/Capacitors!

Failure to disconnect power and discharge capacitors before servicing could result in death or serious injury. Disconnect all electric power, including remote disconnects and discharge all motor start/run capacitors before servicing. Follow proper lockout/tagout procedures to ensure the power cannot be inadvertently energized. For variable frequency drives or other energy storing components provided by Trane or others, refer to the appropriate manufacturer's literature for allowable waiting periods for discharge of capacitors. Verify with a CAT III or IV voltmeter rated per NFPA 70E that all capacitors have discharged.

Important:

- Before servicing, disconnect all power sources and allow at least 20 minutes for capacitors to discharge.
 - All electrical enclosures-unit or remote-are IP2X.
 - Before working on equipment, check for the Status of LED 6: 50Vdc indicator on each Power Cell. When ON, the DC Bus inside the Power Cell has > 50Vdc.
1. Turn off, lock out, and tag the input power to the drive.
 2. Remove the plate from the section of the drive enclosure where the wires will enter.

NOTICE

Equipment Failure!

Debris falling inside of adaptive frequency drive could cause failure of electronic components which could result in damaged equipment. Do not cut holes in adaptive frequency drive enclosure.

3. Once removed, drill the wire routing holes in the panel. These wire routing holes are the only entry points for input power wiring into the cabinet.
4. Install the appropriate conduit hubs.
5. Reinstall the cabinet's panel.
6. Connect the three-phase input power leads to circuit breaker terminals L1, L2, and L3. Tighten these connections to 30 ft-lb (40.7 N·m). Use only copper-conductors for the input power leads. Input power wiring should be copper and should be sized according to applicable codes to handle the drive's continuous rated input current.

Refer to submittals for power lug sizes and location along with control wiring specifics for the controller.

Important: Power connections should be re-torqued after the first three to six months of operation and on an annual basis thereafter.

Torquing Electrical Power Connections

⚠ WARNING

Hazardous Voltage w/Capacitors!

Failure to disconnect power and discharge capacitors before servicing could result in death or serious injury. Disconnect all electric power, including remote disconnects and discharge all motor start/run capacitors before servicing. Follow proper lockout/tagout procedures to ensure the power cannot be inadvertently energized. For variable frequency drives or other energy storing components provided by Trane or others, refer to the appropriate manufacturer's literature for allowable waiting periods for discharge of capacitors. Verify with a CAT III or IV voltmeter rated per NFPA 70E that all capacitors have discharged.

Use a torque wrench to tighten power connections. A torque wrench eliminates the human element and provides proper hardware tightening.

Proper torque for connections depends on both the bolting materials and the metals being connected. Strand migration will occur when the copper is under prolonged pressure.

Electrical power terminations should be rechecked for tightness when the apparatus is first installed and periodically afterwards. The conductor could flow under prolonged pressure. Thermal cycling will be greater during the first few months in operation.

Most hardware used for making a bolted electrical joint will be low carbon steel. The hardware does not carry electrical current but holds the two conducting surfaces together under pressure. When properly torqued, the slight elongation of the bolt or screw acts to maintain pressure on the electrical joint. The thermal expansion of steel is less than that of the conducting metals, which is usually copper.

The pressure at the electrical joint will vary slightly during thermal cycling and reduces somewhat when there is cold flow in the conducting metals. Re-torquing will re-establish the surface pressure, which is essential to keeping a low resistance drop between the two conducting surfaces and avoiding eventual failure.

Cabinet Wire Routing

All wiring should be installed in conformance with the applicable local, national, and international codes (for example, NEC/CEC). Control wiring enters the cabinet through the left side and terminates at the control panel's terminal block. Tighten the control wire connections to 7.1 to 8.9 in·lb (0.8 to 1.0 N·m).

Wire Routing

⚠ WARNING

Proper Field Wiring and Grounding Required!

Failure to follow code could result in death or serious injury. All field wiring **MUST** be performed by qualified personnel. Improperly installed and grounded field wiring poses **FIRE** and **ELECTROCUTION** hazards. To avoid these hazards, you **MUST** follow requirements for field wiring installation and grounding as described in NEC and your local/state/national electrical codes.

Wire Sizing

Care should be taken to see that all interconnection wiring and ground wiring is sized and installed in conformance with the National Electrical Code (NEC), the National Fire Protection Association (NFPA), or the Canadian Electrical Code (CEC) as applicable, and other appropriate local codes. Refer to controller and motor nameplates for electrical data.

Important:

- Before servicing, disconnect all power sources and allow at least 20 minutes for capacitors to discharge.
- All electrical enclosures-unit or remote-are IP2X.

Grounding the Cabinet

Refer to submittals for power lug sizes and location along with control wiring specifics for the controller.

Use the following steps to ground the cabinet:

1. Open the left-hand enclosure door of the drive. The grounding stud is located just above and to the left of the breaker.
2. Run a suitable earth ground (completed by field) to the cabinet's ground connection point. The grounding lug is capable of accepting up to 4/0 AWG wire. For AWG/MCM equivalents in mm², refer to [Table 4, p. 42](#). Tighten the ground connections to 375 in·lb (42.4 N·m).

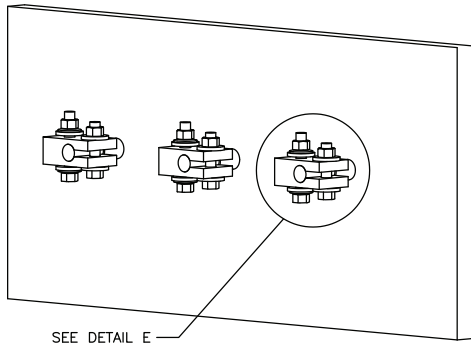
NOTICE

Equipment Damage!

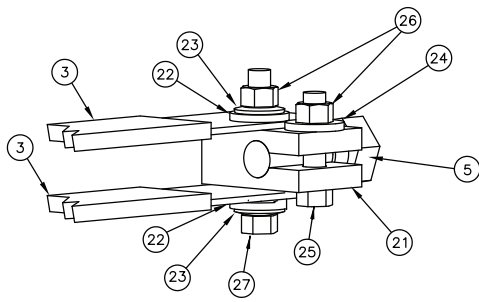
Failure to follow instructions below could cause interference with drive operation and result in damage to the equipment.

Route signal and control wiring separately and in different conduit from power wiring.

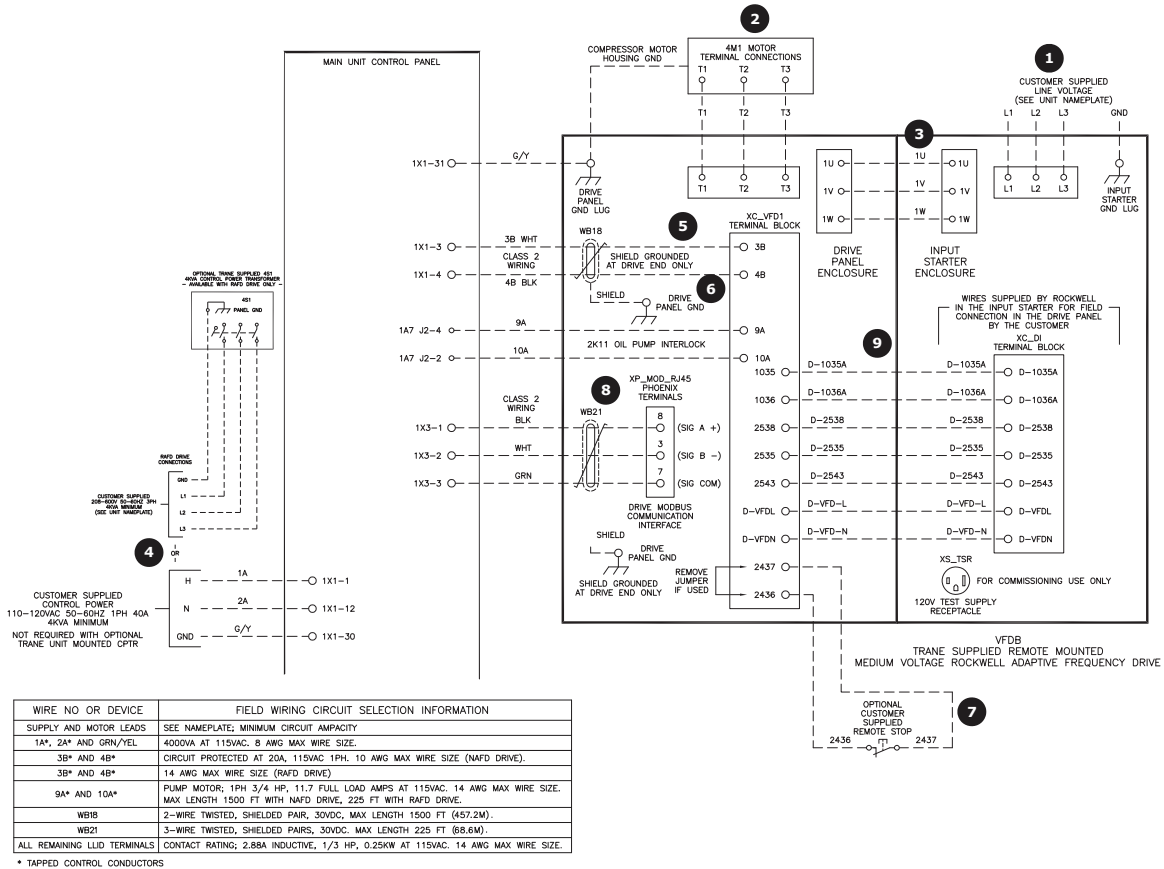
Figure 40. Motor terminal connection



MEDIUM VOLTAGE (2300-6600V)
VFDB, RATR, RPIR, RXL, CSOL, CATR, CPIR, CXL OR CVAC



DETAIL P

Figure 41. RAFD (VFDB) MV drive field connection diagram^(a)

NOTES:

- DASHED LINES INDICATE FIELD WIRING BY OTHERS. WIRE NUMBERS SHOWN ARE RECOMMENDED BY TRANE. REFER TO THE AS-BUILT SCHEMATIC DIAGRAM TO DETERMINE WHICH OPTIONS ARE PRESENT ON THE UNIT.
- DO NOT ROUTE LOW VOLTAGE (30V) WITH CONTROL VOLTAGE (115V) AND DO NOT POWER UNIT UNTIL CHECK-OUT AND START-UP PROCEDURES HAVE BEEN COMPLETED.

- Line power
- Motor-to-drive power
- Cross power wiring
- Chiller control power
- HPC Interlock
 - For medium voltage drives, Dry contact 14 AWG max wire size.
- Oil pump interlock
- Jumper required or remote stop switch
- Chiller-to-drive communication link
- Cross control wiring

(a) For AWG/MCM equivalents in mm², refer to [Table 4, p. 42](#).

Figure 42 illustrates the scope of field wiring for the chiller and drive. Figure 43 illustrates the various field wiring to the drive.

Figure 42. Chiller and PowerFlex 6000T remote configuration

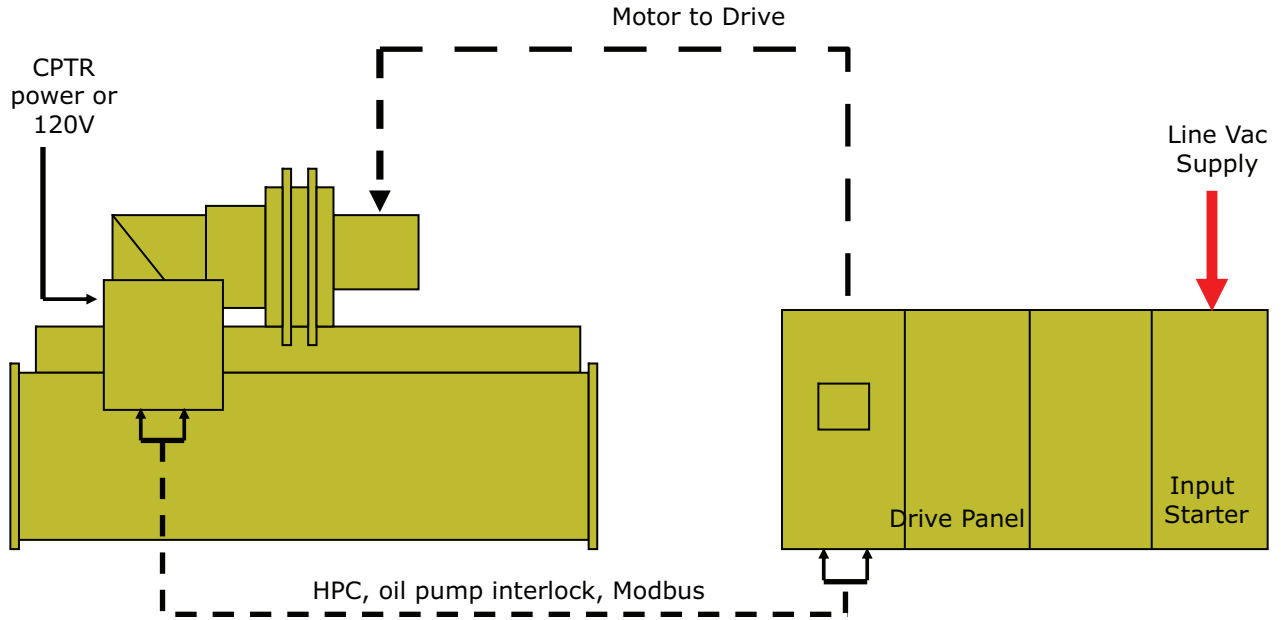
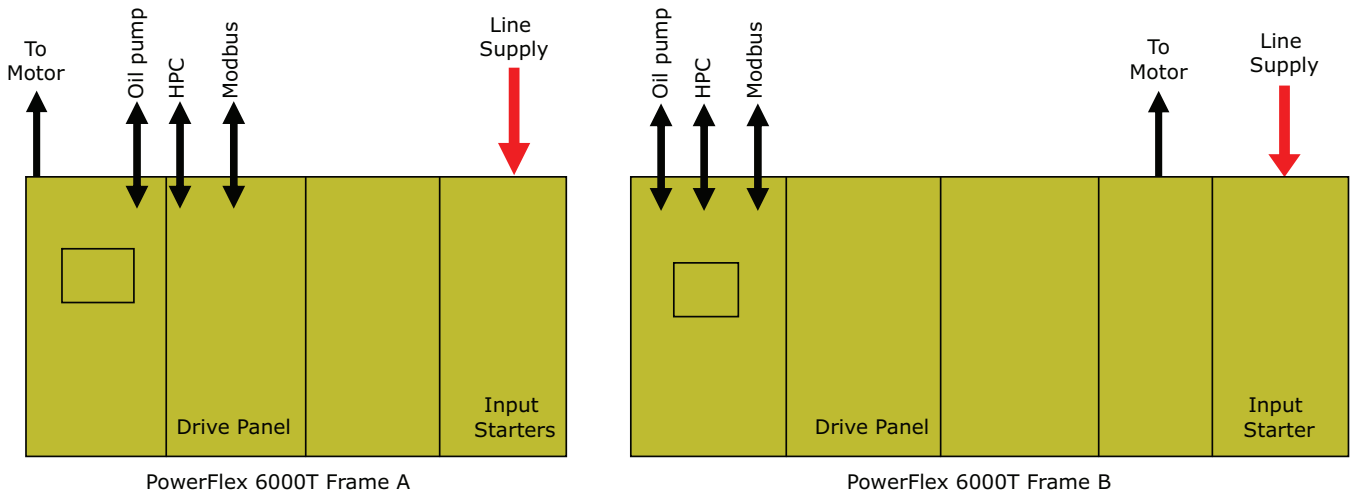


Figure 43. PowerFlex 6000T: Scope of input voltages to/from drive



See sales order for line voltage and other options.

Detailed Field Wiring Points

Input Power and Interconnection Wiring

Table 5 identifies the required power wiring and control wiring related to the MV Drive¹. The Overview illustrates the scope of the field drive related wiring (see Figure 43, p. 46). The MV

drive provides 115 Vac as required for its internal circuits; however, it does not provide the 115 Vac to power up the chiller. Therefore, either the chiller requires external 115 Vac or the CPTR transformer requires its line voltage. Refer to sales order specifications. Items 1 through 9 are identified on Figure 41, p. 45.

Table 5. Power and control wiring

Reference #							
1.	Three-phase line voltage supply to MV drive. (Voltage per sales order.) L1 to L1 L2 to L2 L3 to L3 Grd to Grd						
2.	MV drive to CTV motor terminals. Figure 41, p. 45 illustrates the connection to the chiller motor terminals. T1 to T1 T2 to T2 T3 to T3						
3.	Cross power wiring between input starter and drive panel 1U to 1U 1V to 1V 1W to 1W						
4.	Chiller Control power Chiller control power can be supplied at 115 Vac if without the CPTR transformer, or at a specified voltage if the step down transformer CPTR is specified. Models CDHF, CDHG, CVHE, CVHF, and CVHG 4a) Without CPTR—Connect 115 Vac 40 amps 4 kVA: L1 to 1X1-1 Wire #1A L2 to 1X1-12 Wire #2A Ground to 1X1-G Ground wire 4b) With CPTR transformer—Connect sales order specified voltage: L1 to 4S1-L1 L3 to 4S1-L3 Ground to Ground Models CDHH and CVHH With CPTR transformer—Connect sales order specified voltage: L1 to 6Q1-L1 L2 to 6Q1-L2 Ground to Ground						
5.	High pressure cutout interlock to GateKill (Dry contact input; apply no external power) <table border="0"> <tr> <td>Models CDHF, CDHG, CVHE, CVHF, and CVHG</td> <td>Models CDHH and CVHH</td> </tr> <tr> <td>1X1-3 to 3B; wire #3B</td> <td>1X1-3 to 3B; wire #9E</td> </tr> <tr> <td>1X1-4 to 4B; wire #4B</td> <td>1X1-4 to 4B; wire #4H</td> </tr> </table>	Models CDHF, CDHG, CVHE, CVHF, and CVHG	Models CDHH and CVHH	1X1-3 to 3B; wire #3B	1X1-3 to 3B; wire #9E	1X1-4 to 4B; wire #4B	1X1-4 to 4B; wire #4H
Models CDHF, CDHG, CVHE, CVHF, and CVHG	Models CDHH and CVHH						
1X1-3 to 3B; wire #3B	1X1-3 to 3B; wire #9E						
1X1-4 to 4B; wire #4B	1X1-4 to 4B; wire #4H						
6.	Oil pump interlock (115 Vac circuit; apply no external power) <table border="0"> <tr> <td>Models CDHF, CDHG, CVHE, CVHF, and CVHG</td> <td>Models CDHH and CVHH</td> </tr> <tr> <td>1A7-J2-4 to 9A Wire #9A</td> <td>1X1-10 to 9A Wire #6F</td> </tr> <tr> <td>1A7-J2-2 to 10A Wire #10A</td> <td>1X1-21 to 10A Wire #53F</td> </tr> </table>	Models CDHF, CDHG, CVHE, CVHF, and CVHG	Models CDHH and CVHH	1A7-J2-4 to 9A Wire #9A	1X1-10 to 9A Wire #6F	1A7-J2-2 to 10A Wire #10A	1X1-21 to 10A Wire #53F
Models CDHF, CDHG, CVHE, CVHF, and CVHG	Models CDHH and CVHH						
1A7-J2-4 to 9A Wire #9A	1X1-10 to 9A Wire #6F						
1A7-J2-2 to 10A Wire #10A	1X1-21 to 10A Wire #53F						
7.	Remote stop interlock (Must be jumpered if not used) 2436 2437						

¹ Refer to the chiller *Installation, Operation, and Maintenance* manual for chiller control wiring requirements.



Wiring

Table 5. Power and control wiring (continued)

8. Communications 3-wire Modbus communication link	
Models CDHF, CDHG, CVHE, CVHF, and CVHG	Models CDHH and CVHH
1X3-1 to terminal #8 (Black)	1X3-1 to terminal #8 (Black)
1X3-2 to terminal #3 (White)	1X3-2 to terminal #3 (White)
1X3-3 to terminal #7 (Green)	1X3-3 to terminal #7 (Green)
Shield Ground one end at drive end only	Shield Ground one end at drive end only
9. Cross control wiring between input starter and drive panel	
1035 to D-1035A, wire #D-1035A	
1036 to D-1036A, wire #D-1036A	
2538 to D-2538, wire #D-2538	
2535 to D-2535, wire #D-2535	
2543 to D-2543, wire #D-2543	
D-VFDL to D-VFDL, wire #D-VFD-L	
D-VFDN to D-VFDN, wire #D-VFD-N	

Figure 41, p. 45 illustrates the nine preceding items (input power and interconnection wiring) and Figure 40, p. 44 illustrates the CTV motor terminals supplied on the chiller motor terminal ground.

NOTICE

Equipment Damage!

**Failure to follow instructions below could result in equipment damage.
Follow all recommended best wiring practices.**

Follow the best wiring practices outlined below:

- Do NOT bundle input/output cables together.
- Power cable tray must be a minimum of 12 inches (300 mm).
- Ensure no gaps are present at the connection of the conduit to the cabinet.
- Spacing between wire groups is the recommended minimum for parallel runs of approximately 200 ft (61 m) or less.
- Use only the conduit entrance holes of the cabinet for all power wiring (input and output), control wiring, and conduit.
- Ensure connectors are adequately rated according to the environmental rating of the cabinet.
- Route control and power wiring separately. The distance between the control cable tray and power cable tray must be 11.8 in (300 mm) minimum.
- Do NOT mix AC and DC wires within the same cable bundle.



Pre-Commissioning Start-Up

Trane VFDB MV Drive

Check List

Prior to pre-commissioning start-up, it is imperative for Rockwell and Trane to receive a completed copy of the Power Flex "A" or "B" Frame Pre-Commissioning Check List as soon as possible. The check list is included at the end of this manual, and also as a separate form, AFDJ-AFD001*-EN.

Commissioning

NOTICE

Perform Visual Inspection!

The conditions listed below could cause equipment damage. Before powering up this drive for the first time conduct a visual inspection for the following:

- Shipping damage.
- Signs of moisture.
- Signs of debris or dust from storage.
- Signs of corrosion on components and/or enclosure.

Do not power up equipment if you have concerns regarding equipment condition. Upon initial power up, remain in the area for the first two hours of operation and observe the chiller and drive for any abnormalities. Contact CenTraVac Technical Support for assistance if needed.

⚠ WARNING

Hazardous Voltage!

Failure to close all enclosure doors and properly secure with fasteners before operating equipment could result in death or serious injury due to hazardous voltage.

Important:

- Before servicing, disconnect all power sources and allow at least 20 minutes for capacitors to discharge.
- All electrical enclosures-unit or remote-are IP2X.

Start-Up Commissioning Services

Start-up will be performed at the customer's site. Rockwell Automation requests a minimum of four weeks' notice to schedule each start-up. The local Trane office will request Rockwell start-up upon completion and readiness as per the pre-commissioning checklist.

The standard Rockwell Automation work hours are between 8:00 am and 5:00 pm EST (8 h/day) Monday through Friday, not including observed holidays. Additional working hours are available on a time and material basis.

Note: Do not apply power to the drive prior to Rockwell site visit. Damages resulting from improper wiring and power-up will not be covered by warranty.

Drive Commissioning

1. A pre-installation meeting with the customer to review:
 - The Rockwell automation start-up plan
 - The start-up schedule
 - The drive(s) installation requirements
 2. Inspect the drive's mechanical and electrical devices.
 3. Verify internal connections within the drive and verify wiring.
 4. Verify critical mechanical connections for proper torque requirements.
 5. Verify and adjust mechanical interlocks for permanent location.
 6. Confirm all inter-sectional wiring is connected properly.
 7. Re-verify control wiring from any external control devices.
 8. Confirm cooling system is operational.
 9. Verification of proper phasing from input voltage source to drive.
 10. Confirm cabling of drive to motor, isolation transformer, and line feed.
 11. Collect test reports indicating megger/hi-pot test has been performed on line and motor cables.
 12. Control power checks to verify all system inputs such as starts/stops, faults, and other remote inputs.
 13. Apply medium voltage to the drive and perform operational checks.
- Note:** At this point, coordinate with Rockwell so that unit is charged and oil pump is working.
14. Bump motor for rotation check and tune drive to the system attributes. (If the load is unable to handle any movement in the reverse direction, the load should be uncoupled prior to bumping the motor for directional testing).
 15. Run the drive motor system throughout the operational range to verify proper performance.
- Note:** Customer personnel will be required on-site to participate in the start-up of the system.
16. Log operation of chiller and drive for start-up documentation.



Maintenance

Preventive Maintenance Check List

The preventive maintenance activities on the PF6000T Air-Cooled Drive (“A” Frame or “B” Frame) can be broken down into two categories:

- Operational Maintenance—can be completed while the drive is running.
- Annual Maintenance—should be completed during scheduled downtime.

Operational Maintenance

Check the following items during normal operation of the drive:

- Abnormal noise or vibration in the drive or motor
- Abnormal temperature in the drive or motor
- Ambient temperature in the control room above nominal
- Accumulation of dust or particulate on control room floor or surfaces
- Abnormal load current above nominal

Clean the Air Filters

PowerFlex 6000T drives require a continuous, smooth airflow to cool the power components and the isolation transformer to deliver stable and reliable operation of the equipment. Obstruction of the air filters is the main cause of poor cooling airflow.

The drive uses a number of cooling fans that are installed at the top of the cabinet to deliver sufficient airflow to cool the power components and isolation transformer. When the equipment is running for some time, the air filters accumulate dust and obstructs the airflow. Failure to clean the air filters regularly may result in insufficient cooling airflow, which may cause some parts of the drive to send an over temperature alarm or even trip:

- Transformer over temperature alarm/trip
- Power cell over temperature trip

Immediately after receiving the over temperature warning, you should plan to replace or clean the air filters. At this point there should be a few days or weeks before the air filters fail, but this depends on the amount of dust in the environment.

Annual Maintenance

As the name implies, these maintenance tasks should be performed on an annual basis by a qualified MV drive technician. These are recommended tasks, and depending on the installation conditions and operating conditions, you may find that the interval can be lengthened.

Initial Information Gathering by Qualified MV Drive Technician

Connected Components Workbench (CCW) is Rockwell service tool that can be used to upload and download parameter configuration and monitor system parameters for PF6000T drive. A qualified MV drive technician will complete drive parameters and DeviceLogix program setup during first commission.

Physical Checks (NO Medium Voltage and NO Control Power)

⚠ WARNING

Hazardous Voltage!

Failure to disconnect power before servicing could result in death or serious injury. Disconnect all electric power, including remote disconnects before servicing. Follow proper lockout/tagout procedures to ensure the power can not be inadvertently energized. Verify that no power is present with a voltmeter.

Important: Before servicing, disconnect all power sources and allow at least 20 minutes for capacitors to discharge.

Power Connection Inspection

- Inspect PowerFlex 6000T drive, input/output/bypass sections, and all associated drive components for loose power cable connections and ground cable connections: torque them based on the required torque specifications.
- Inspect the bus bars and check for any signs of overheating/discoloration and tighten the bus connections to the required torque specifications.
- Clean all cables and bus bars that exhibit dust build-up.
- The torques of incoming/outgoing cable screws of the power unit shall be checked if they are in the specified range.
- Use torque sealer on all connections. Conduct integrity checks on the signal ground and safety grounds.

Physical Inspection

- Check for any visual/physical evidence of damage or degradation of components in the low voltage compartments.
 - This includes relays, contractors, timers, terminal connectors, circuit breakers, ribbon cables, control wires, optional UPS, AC/DC power supplies, and so on. Causes could be corrosion, excessive temperature, or contamination.
- Check for any visual/physical evidence of damage or degradation of components in the medium voltage



Maintenance

compartments (cables, contractors, circuit breakers, isolation disconnecting blades, power units, and so on).

- This includes main cooling fan, power devices, heatsinks, circuit boards, insulators, cables, capacitors, current transformers, potential transformers, fuses, wiring, and so on; Causes could be corrosion, excessive temperature, or contamination.
- Clean all contaminated components using a vacuum cleaner (DO NOT use a blower), and wipe clean components where appropriate.
- Conduct the physical inspection and verification for the proper operation of the contractor/isolator interlocks, and door interlocks.
- Conduct the physical inspection and verification for the proper operation of the key interlocks.
- Conduct the cleaning of the fans and verify that the ventilation passages are not blocked and the impellers are freely rotating without any obstruction.
- Conduct the insulation resistance (IR) test on the transformer, motor, and associated cabling.
- Check all bolts for fastening and adjust them as necessary.
- Check all labels for readability. If any labels are unreadable, damaged, or missing, contact Rockwell Automation for replacements.

Chiller Operator Display Content

Refer to *Operations Guide: Tracer AdaptiView™ Display for Water-Cooled CenTraVac™ Chillers* (CTV-SVU01*-EN, or the most recent version) for Tracer AdaptiView display information.

Troubleshooting

Alarms

When an active alarm is present, it is identified in the **Alarms** button in the lower left corner of the Tracer AdaptiView display. This serves two purposes. First to alert the operator that an alarm exists, and second to provide navigation to the Alarms list.

Clicking on the active alarms causes the Alarms list to display. All active alarms are listed first and ordered by the alarm's severity. The severity hierarchy is:

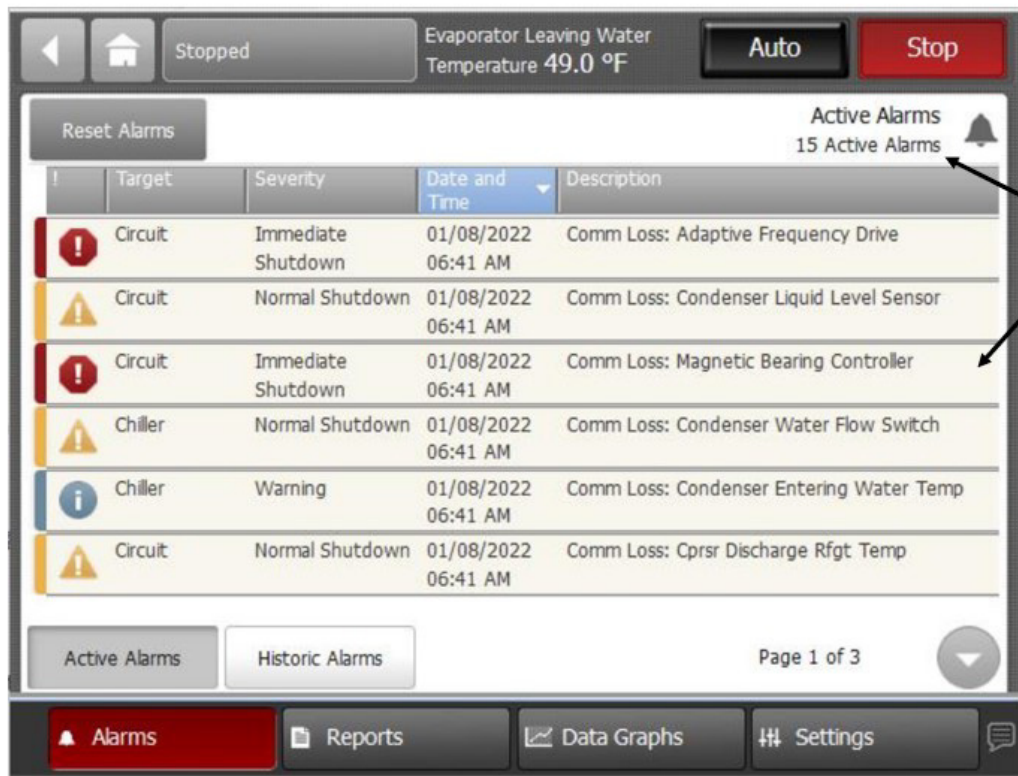
- Immediate shutdown (highest priority and displays first)
- Normal shutdown
- Warning

- Unknown (lowest priority and displays last)

Active alarms are followed by any historical alarms. These appear gray on the screen. The alarms button at the bottom of the screen flashes between two colors depending on the severity of the highest priority alarm (i.e., Immediate shutdown alarms cause the button to flash between red and black, and Normal shutdown alarms cause the button to flash between yellow and black).

You can also connect the laptop computer loaded with the Tracer TU service tool software directly to the Symbio 800 controller to view the AFD last diagnostic code (refer to [Table 6, p. 54](#) for detailed information on which AFD settings you can see using Tracer TU).

Figure 44. Tracer AdaptiView alarms screen



Active alarms

Troubleshooting

This section can assist in field troubleshooting Communicating MV drives, and can provide information, which others can use to help you troubleshoot the drive.

1. Collect alarm and parameter information.
 - a. DO NOT cycle unit power or reset the controls. Leave the AFD and the Symbio™ 800 in their present states.
2. Collect Chiller Information.
 - a. Note the following chiller information:
 - b. Record the AFD Last Diagnostic Code using Tracer TU. This value is available under the Unit Status tab, in the AF (Adjustable Frequency) expanding box.
 - c. Record all Symbio 800 active and historic alarms. Make a full chiller service report.
 - d. Document and check all applicable parameter settings. This information can be verified off of the chiller nameplate, and by referring to this manual.



Troubleshooting

- Operating mode and any sub-mode (i.e., 100 percent or 75 percent load etc.)
 - Number of chiller starts, and hours of operation.
 - Time since last diagnostic shutdown (<1 minute, <1 hour, >1 hour, etc.)
- b. What was the chiller state at the time of the failure? (Chiller starting? Running low load? Running full load? etc.)
 - c. Record the chiller's sales order and serial numbers, and the drive's serial and model numbers.
3. Troubleshooting
 - a. Note drive information and codes from drive display.
 - b. Refer to the Rockwell manuals for further troubleshooting information.
 - c. Contact Trane Service Company for assistance.

Table 6 coordinates the chiller's Tracer Symbio 800 drive diagnostics and the Rockwell MV drive diagnostics fault and reference MV drive fault code. For additional information on the faults, refer to the Rockwell PowerFlex 6000T MV AC Drive Technical Data section (Chapter 3) of the manual that shipped with the drive. Only qualified technicians should attempt any troubleshooting of the drive and chiller. Contact your local Trane Service agency to request service and/or additional support. Trane can contact the appropriate technical service group for additional support if necessary.

Table 6. IOM Tracer Symbio 800 and drive diagnostics

Chiller Tracer Symbio 800 Diagnostic	MV Drive Diagnostic	Drive Fault
AFD Bus Over Voltage	OverVoltage	10107
AFD Bus Under Voltage	UnderVoltage	10106
AFD Bus Under Voltage	DC Bus Under Vltg	10209
AFD Bus Under Voltage	U0-U8_DCBusUnderVltg	12510
AFD Bus Under Voltage	U0-U8_DCBusUnderVltg	12511
AFD Bus Under Voltage	U0-U8_DCBusUnderVltg	12512
AFD Bus Under Voltage	U0-U8_DCBusUnderVltg	12513
AFD Bus Under Voltage	U0-U8_DCBusUnderVltg	12514
AFD Bus Under Voltage	U0-U8_DCBusUnderVltg	12515
AFD Bus Under Voltage	U0-U8_DCBusUnderVltg	12516
AFD Bus Under Voltage	U0-U8_DCBusUnderVltg	12517
AFD Bus Under Voltage	U0-U8_DCBusUnderVltg	12518
AFD Bus Under Voltage	V0-V8_DCBusUnderVltg	12520
AFD Bus Under Voltage	V0-V8_DCBusUnderVltg	12521
AFD Bus Under Voltage	V0-V8_DCBusUnderVltg	12522
AFD Bus Under Voltage	V0-V8_DCBusUnderVltg	12523
AFD Bus Under Voltage	V0-V8_DCBusUnderVltg	12524
AFD Bus Under Voltage	V0-V8_DCBusUnderVltg	12525
AFD Bus Under Voltage	V0-V8_DCBusUnderVltg	12526
AFD Bus Under Voltage	V0-V8_DCBusUnderVltg	12527

Table 6. IOM Tracer Symbio 800 and drive diagnostics (continued)

Chiller Tracer Symbio 800 Diagnostic	MV Drive Diagnostic	Drive Fault
AFD Bus Under Voltage	V0-V8_DCBusUnderVltg	12528
AFD Bus Under Voltage	W0-8_DCBusUnderVltg	12530
AFD Bus Under Voltage	W0-8_DCBusUnderVltg	12531
AFD Bus Under Voltage	W0-8_DCBusUnderVltg	12532
AFD Bus Under Voltage	W0-8_DCBusUnderVltg	12533
AFD Bus Under Voltage	W0-8_DCBusUnderVltg	12534
AFD Bus Under Voltage	W0-8_DCBusUnderVltg	12535
AFD Bus Under Voltage	W0-8_DCBusUnderVltg	12536
AFD Bus Under Voltage	W0-8_DCBusUnderVltg	12537
AFD Bus Under Voltage	W0-8_DCBusUnderVltg	12538
AFD Ground Fault	L Ground Warning	13047
AFD Motor Current Overload	Motor Overload	10003
AFD Motor Current Overload	SW OverCurrent	10092
AFD Motor Current Overload	Mtr OverCurrent	10218
AFD Motor Current Overload	Drv Overcurrent	10216
AFD Motor Current Overload	HW OverCurrent	10093
AFD Instantaneous Current Overload	U0-U8/V0-V8/W0-W8 IGBT Overcurrent	12150
AFD Instantaneous Current Overload	U0-U8/V0-V8/W0-W8 IGBT Overcurrent	12151
AFD Instantaneous Current Overload	U0-U8/V0-V8/W0-W8 IGBT Overcurrent	12152
AFD Instantaneous Current Overload	U0-U8/V0-V8/W0-W8 IGBT Overcurrent	12153
AFD Instantaneous Current Overload	U0-U8/V0-V8/W0-W8 IGBT Overcurrent	12154
AFD Instantaneous Current Overload	U0-U8/V0-V8/W0-W8 IGBT Overcurrent	12155
AFD Instantaneous Current Overload	U0-U8/V0-V8/W0-W8 IGBT Overcurrent	12156
AFD Instantaneous Current Overload	U0-U8/V0-V8/W0-W8 IGBT Overcurrent	12157
AFD Instantaneous Current Overload	U0-U8/V0-V8/W0-W8 IGBT Overcurrent	12158
AFD Instantaneous Current Overload	U0-U8/V0-V8/W0-W8 IGBT Overcurrent	12170
AFD Instantaneous Current Overload	U0-U8/V0-V8/W0-W8 IGBT Overcurrent	12171
AFD Instantaneous Current Overload	U0-U8/V0-V8/W0-W8 IGBT Overcurrent	12172
AFD Instantaneous Current Overload	U0-U8/V0-V8/W0-W8 IGBT Overcurrent	12173
AFD Instantaneous Current Overload	U0-U8/V0-V8/W0-W8 IGBT Overcurrent	12174
AFD Instantaneous Current Overload	U0-U8/V0-V8/W0-W8 IGBT Overcurrent	12175
AFD Instantaneous Current Overload	U0-U8/V0-V8/W0-W8 IGBT Overcurrent	12176
AFD Instantaneous Current Overload	U0-U8/V0-V8/W0-W8 IGBT Overcurrent	12177

Table 6. IOM Tracer Symbio 800 and drive diagnostics (continued)

Chiller Tracer Symbio 800 Diagnostic	MV Drive Diagnostic	Drive Fault
AFD Instantaneous Current Overload	U0-U8/V0-V8/W0-W8 IGBT Overcurrent	12178
AFD Instantaneous Current Overload	U0-U8/V0-V8/W0-W8 IGBT Overcurrent	12190
AFD Instantaneous Current Overload	U0-U8/V0-V8/W0-W8 IGBT Overcurrent	12191
AFD Instantaneous Current Overload	U0-U8/V0-V8/W0-W8 IGBT Overcurrent	12192
AFD Instantaneous Current Overload	U0-U8/V0-V8/W0-W8 IGBT Overcurrent	12193
AFD Instantaneous Current Overload	U0-U8/V0-V8/W0-W8 IGBT Overcurrent	12194
AFD Instantaneous Current Overload	U0-U8/V0-V8/W0-W8 IGBT Overcurrent	12195
AFD Instantaneous Current Overload	U0-U8/V0-V8/W0-W8 IGBT Overcurrent	12196
AFD Instantaneous Current Overload	U0-U8/V0-V8/W0-W8 IGBT Overcurrent	12197
AFD Instantaneous Current Overload	U0-U8/V0-V8/W0-W8 IGBT Overcurrent	12198
AFD Power Loss	Power Loss	10001
AFD Power Loss	PowerLoss Det	13005
AFD Motor Fault	Load Loss	10004
AFD Motor Fault	Output PhaseLoss	10008
AFD Precharge Fault	Bus Rate of Rise	13075
AFD Precharge Fault	PrchrgDvcFailCls	188
AFD Precharge Fault	PrchrgDvcFailOpn	189
AFD Precharge Fault	PrchrgDvcMismatch	192
AFD Precharge Fault	PrchrgDvc CfgErr	288
AFD Over Temperature	Powercell / Transformer Over Temperature	12210
AFD Over Temperature	Powercell / Transformer Over Temperature	12211
AFD Over Temperature	Powercell / Transformer Over Temperature	12212
AFD Over Temperature	Powercell / Transformer Over Temperature	12213
AFD Over Temperature	Powercell / Transformer Over Temperature	12214
AFD Over Temperature	Powercell / Transformer Over Temperature	12215
AFD Over Temperature	Powercell / Transformer Over Temperature	12216
AFD Over Temperature	Powercell / Transformer Over Temperature	12217
AFD Over Temperature	Powercell / Transformer Over Temperature	12218
AFD Over Temperature	Powercell / Transformer Over Temperature	12230
AFD Over Temperature	Powercell / Transformer Over Temperature	12231
AFD Over Temperature	Powercell / Transformer Over Temperature	12232

Table 6. IOM Tracer Symbio 800 and drive diagnostics (continued)

Chiller Tracer Symbio 800 Diagnostic	MV Drive Diagnostic	Drive Fault
AFD Over Temperature	Powercell / Transformer Over Temperature	12233
AFD Over Temperature	Powercell / Transformer Over Temperature	12234
AFD Over Temperature	Powercell / Transformer Over Temperature	12235
AFD Over Temperature	Powercell / Transformer Over Temperature	12236
AFD Over Temperature	Powercell / Transformer Over Temperature	12237
AFD Over Temperature	Powercell / Transformer Over Temperature	12238
AFD Over Temperature	Powercell / Transformer Over Temperature	12250
AFD Over Temperature	Powercell / Transformer Over Temperature	12251
AFD Over Temperature	Powercell / Transformer Over Temperature	12252
AFD Over Temperature	Powercell / Transformer Over Temperature	12253
AFD Over Temperature	Powercell / Transformer Over Temperature	12254
AFD Over Temperature	Powercell / Transformer Over Temperature	12255
AFD Over Temperature	Powercell / Transformer Over Temperature	12256
AFD Over Temperature	Powercell / Transformer Over Temperature	12257
AFD Over Temperature	Powercell / Transformer Over Temperature	12258
AFD Over Temperature	Powercell / Transformer Over Temperature	14245
AFD Over Temperature	Powercell / Transformer Over Temperature	14247
AFD Over Temperature	Powercell / Transformer Over Temperature	14249
AFD General Failure	All other faults	
AFD Gate Kill active		

LED Usage

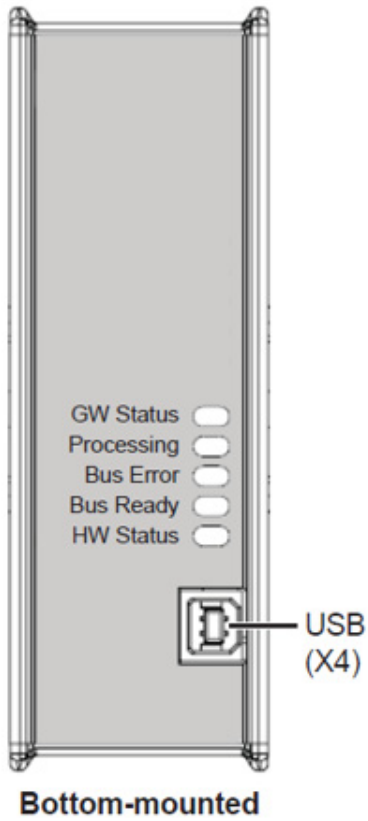
Anybus gateway AB7678 is selected for communication between Modbus RTU and Ethernet networks. See more details at www.anybus.com

There are five LEDs on the gateway for Modbus RTU status:

LED	Color	Indication
Gateway Status	Refer to the user manual for further details	
Processing	Green	Processing message
	Off	Not processing
Bus Error	Red	Bus error
	Off	Normal operation

Troubleshooting

LED	Color	Indication
Bus Ready	Green	Normal operation
	Red	Bus timeout error
	Off	Bus not running
HW Status	Red	Configuration switch error
	Off	-





PowerFlex “A” or “B” Frame Pre-Commissioning Check List

Remote-Mounted Medium Voltage Air-Cooled Adaptive Frequency™ Drives:
PowerFlex 7000 (Model: AFDJ)
PowerFlex 6000T (Model: VFDB)

WARNING

Safety Alert!

Failure to follow instructions below could result in death or serious injury. In addition to the following tasks, you **MUST**:

- Follow all instructions in the unit's *Installation, Operation, and Maintenance* manual, including warnings, cautions, and notices.
- Perform all required tasks in any applicable Service Alerts and Service Bulletins.
- Review and understand all information provided in Submittals and Design Specifications.

WARNING

Hazardous Service Procedures!

Failure to follow all precautions in this manual and on the tags, stickers, and labels could result in death or serious injury.

Technicians, in order to protect themselves from potential electrical, mechanical, and chemical hazards, **MUST** follow precautions in this manual and on the tags, stickers, and labels, as well as the following instructions: Unless specified otherwise, disconnect all electrical power including remote disconnect and discharge all energy storing devices such as capacitors before servicing. Follow proper lockout/tagout procedures to ensure the power can not be inadvertently energized. When necessary to work with live electrical components, have a qualified licensed electrician or other individual who has been trained in handling live electrical components perform these tasks.

WARNING

Personal Protective Equipment (PPE) Required!

Failure to wear proper PPE for the job being undertaken could result in death or serious injury. Technicians, in order to protect themselves from potential electrical, mechanical, and chemical hazards, **MUST** follow precautions in this manual and on the tags, stickers, and labels, as well as the instructions below:

- Before installing/servicing this unit, technicians **MUST** put on all PPE required for the work being undertaken (Examples; cut resistant gloves/sleeves, butyl gloves, safety glasses, hard hat/bump cap, fall protection, electrical PPE and arc flash clothing). **ALWAYS** refer to appropriate Safety Data Sheets (SDS) and OSHA guidelines for proper PPE.
- When working with or around hazardous chemicals, **ALWAYS** refer to the appropriate SDS and OSHA/ GHS (Global Harmonized System of Classification and Labelling of Chemicals) guidelines for information on allowable personal exposure levels, proper respiratory protection and handling instructions.
- If there is a risk of energized electrical contact, arc, or flash, technicians **MUST** put on all PPE in accordance with OSHA, NFPA 70E, or other country-specific requirements for arc flash protection, **PRIOR** to servicing the unit. **NEVER PERFORM ANY SWITCHING, DISCONNECTING, OR VOLTAGE TESTING WITHOUT PROPER ELECTRICAL PPE AND ARC FLASH CLOTHING. ENSURE ELECTRICAL METERS AND EQUIPMENT ARE PROPERLY RATED FOR INTENDED VOLTAGE.**

WARNING

Proper Field Wiring and Grounding Required!

Failure to follow code could result in death or serious injury. All field wiring **MUST** be performed by qualified personnel. Improperly installed and grounded field wiring poses **FIRE** and **ELECTROCUTION** hazards. To avoid these hazards, you **MUST** follow requirements for field wiring installation and grounding as described in NEC and your local/state/national electrical codes.

Instructions

It is imperative for Rockwell and Trane to receive the following check list information filled out as soon as possible and sent to Rockwell Medium Voltage Center of Expertise in Cambridge, Ontario, Canada office and to the regional Trane Technical Support Team to assure scheduling is not a problem (see contact information below for more information).

Note: A pre-commissioning check sheet is required for each drive and compressor being prepared for start-up. In the case of multiple simplex chillers, this means that a pre-commissioning sheet for each chiller and drive is required. In the case of a Duplex chiller, two pre-commissioning copies are required: once for Circuit 1 (left-hand) and a second for Circuit 2 (right-hand).

Important:

- The average start-up by Rockwell takes approximately three days to complete.
- You must specify the language for warning labels in the pre-commissioning check list (see next page).
- **Rockwell requires four weeks notice to make arrangements.**

After completing the pre-commissioning check list, fax or e-mail to the appropriate regional Rockwell and Trane office:

North America Region	
Rockwell	<ul style="list-style-type: none"> • E-mail: mvsupport_technical@ra.rockwell.com • Phone: (440) 646-3434 or (888) 382-1583 (choose options 3, 5, and enter code 513) <p>Note: The end user requires a valid Tech Connect contract to get support from Rockwell.</p>
Trane	<ul style="list-style-type: none"> • Fax: (608) 787-3024 • E-mail: TechSupportLaCrosse@trane.com

Europe Middle East Africa Region	
Rockwell	<ul style="list-style-type: none"> • E-mail: mvsupport_services@ra.rockwell.com
Trane	<ul style="list-style-type: none"> • E-mail: EMEAtechnicalsupport@trane.com

Table 7. Torque requirements for threaded fasteners^(a)

Diameter	Pitch	Material	Torque	
			ft·lb	N·m
M2.5	0.45	Steel	0.32	0.43
M4	0.7	Steel	1.3	1.8
M5	0.8	Steel	2.5	3.4
M6	1	Steel	4.4	6.0
M8	1.25	Steel	11	14
M10	1.5	Steel	21	29
M12	1.75	Steel	37	50
M14	2	Steel	60	81
1/4 in.	20	Steel S.A.E. 5	9.0	12
3/8 in.	16	Steel S.A.E. 2	20	27

(a) Unless otherwise specified, use the values of torque in this table in maintaining the equipment.

Once all points of the check list are complete, initial each check box and provide the date. (It will be necessary to review this with the electrician or electrical contractor.)

Photocopy the check list and fax the copy to the Medium Voltage Center of Expertise (MVCOE) and to Trane Technical support along with the planned start-up date.

Upon receiving this check list, the Rockwell MVCOE group will contact the site to finalize arrangements for a start-up engineer to travel to site. The field service agency and Rockwell are to also coordinate the visit with La Crosse CTV Technical Service.

PowerFlex “A” or “B” Frame Pre-Commissioning Check List

Please complete (print) this **Pre-Commissioning Check List** and when complete, fax or e-mail to Rockwell and Trane (contact information provided on preceding page):

Required: Specify Language for Warning Labels! _____

FROM: _____ **Date:** _____

Name: _____

Trane Service Company: _____

Pages: _____

Trane Regional Fax: _____

Rockwell Regional E-mail: _____

Trane Regional E-mail: _____

Trane Chiller Serial Number: _____

Trane Chiller Sales Order Number: _____

MV Drive Serial Number: _____

Rockwell GMS Service Engineer Requested (YES): _____

Scheduled Commissioning Date^(a): _____

(a) **Important:**

*The average start-up by Rockwell takes approximately three days to complete.
Rockwell requires four weeks notice to make arrangements.*

1. Receiving and Unpacking

Initials Date

	<input type="checkbox"/> The drives have been checked for shipping damage upon receiving.
	<input type="checkbox"/> Check the shock indicator; call Trane Service and Rockwell support to notify if damaged.
	<input type="checkbox"/> After unpacking, the item(s) received are verified against the bill of materials.
	<input type="checkbox"/> Any claims for breakage or damage, whether concealed or obvious, are made to the carrier by the customer as soon as possible after receipt of shipment. Any claims shall be issued according to local legislation.
	<input type="checkbox"/> All packing material, wedges, or braces are removed from the drive.



2. Installation / Mounting

Initials Date

- | | |
|--------------------------|--|
| <input type="checkbox"/> | The drive is securely fastened in an upright position, on a level surface. Seismic zones require special fastenings; consult Rockwell. |
| <input type="checkbox"/> | Lifting angles have been removed. |
| <input type="checkbox"/> | Bolts have been inserted into original location on top of drive (leakage of cooling air). |
| <input type="checkbox"/> | All contactors and relays have been operated manually to verify free movement. |
| <input type="checkbox"/> | For model 7000, frame A only, install neutral resistors. Not applicable for PF6000T model VFDB. |

3. Safety

Initials Date

- | | |
|--------------------------|---|
| <input type="checkbox"/> | All mechanical interlocks and door Ram Interlocks are tested for proper functionality and are not defeated or damaged. |
| <input type="checkbox"/> | All Kirk key interlocks are installed and tested for proper functionality. |
| <input type="checkbox"/> | The grounding of the drive should be in accordance with CEC (Canadian Electrical Code), NEC (National Electrical Code), IEC regulations, and/or local regulations.
Note: <i>To be completed by Electrical Contractor.</i> |
| <input type="checkbox"/> | If the drive has an isolation transformer, the transformer enclosure and/or frame must be bonded to system ground at a minimum of two locations. |
| <input type="checkbox"/> | If the drive has an isolation transformer, the wye secondary neutral point must not be grounded. |
| <input type="checkbox"/> | If shipping splits exist in the line-up, the ground bus between cabinets has been installed. |

4. Control Wiring

Initials Date

- | | |
|--------------------------|---|
| <input type="checkbox"/> | All low voltage wiring entering the drive is labeled, appropriate wiring diagrams are available, and all customer interconnections are complete. |
| <input type="checkbox"/> | Oil pump interlock complete |
| <input type="checkbox"/> | All AC and DC circuits are run in separate conduits. |
| <input type="checkbox"/> | All wire sizes used are selected by observing all applicable safety and CEC/NEC/IEC regulations.
Note: <i>To be completed by Electrical Contractor.</i> |
| <input type="checkbox"/> | All 3-phase control wiring is within specified levels and has been verified for proper rotation, UVW. |
| <input type="checkbox"/> | All single-phase control wiring is within specified levels and has grounded neutrals. |
| <input type="checkbox"/> | Pre-trip status from customer-supplied breaker. |

Trane - by Trane Technologies (NYSE: TT), a global climate innovator - creates comfortable, energy efficient indoor environments for commercial and residential applications. For more information, please visit trane.com or tranetechnologies.com.

Trane has a policy of continuous product and product data improvement and reserves the right to change design and specifications without notice. We are committed to using environmentally conscious print practices.

Trane - by Trane Technologies (NYSE: TT), a global climate innovator - creates comfortable, energy efficient indoor environments for commercial and residential applications. For more information, please visit trane.com or tranetechnologies.com.

Trane has a policy of continuous product and product data improvement and reserves the right to change design and specifications without notice. We are committed to using environmentally conscious print practices.