



# Installation, Operation, and Maintenance

## **Vertical Classroom Unit Ventilator**

### Model VUV

### 750 CFM to 1500 CFM



#### **▲ SAFETY WARNING**

Only qualified personnel should install and service the equipment. The installation, starting up, and servicing of heating, ventilating, and air-conditioning equipment can be hazardous and requires specific knowledge and training. Improperly installed, adjusted or altered equipment by an unqualified person could result in death or serious injury. When working on the equipment, observe all precautions in the literature and on the tags, stickers, and labels that are attached to the equipment.

June 2026

**UV-SVX006D-EN**

**TRANE**  
TECHNOLOGIES™



# Introduction

Read this manual thoroughly before operating or servicing this unit.

## Warnings, Cautions, and Notices

Safety advisories appear throughout this manual as required. Your personal safety and the proper operation of this machine depend upon the strict observance of these precautions.

The three types of advisories are defined as follows:



Indicates a potentially hazardous situation which, if not avoided, could result in death or serious injury.



Indicates a potentially hazardous situation which, if not avoided, could result in minor or moderate injury. It could also be used to alert against unsafe practices.



Indicates a situation that could result in equipment or property-damage only accidents.

## Important Environmental Concerns

Scientific research has shown that certain man-made chemicals can affect the earth's naturally occurring stratospheric ozone layer when released to the atmosphere. In particular, several of the identified chemicals that may affect the ozone layer are refrigerants that contain Chlorine, Fluorine and Carbon (CFCs) and those containing Hydrogen, Chlorine, Fluorine and Carbon (HCFCs). Not all refrigerants containing these compounds have the same potential impact to the environment. Trane advocates the responsible handling of all refrigerants.

## Important Responsible Refrigerant Practices

Trane believes that responsible refrigerant practices are important to the environment, our customers, and the air conditioning industry. All technicians who handle refrigerants must be certified according to local rules. For the USA, the Federal Clean Air Act (Section 608) sets forth the requirements for handling, reclaiming, recovering and recycling of certain refrigerants and the equipment that is used in these service procedures. In addition, some states or municipalities may have additional requirements that must also be adhered to for responsible management of refrigerants. Know the applicable laws and follow them.

### ⚠ WARNING

#### Proper Field Wiring and Grounding Required!

Failure to follow code could result in death or serious injury.

All field wiring **MUST** be performed by qualified personnel. Improperly installed and grounded field wiring poses **FIRE** and **ELECTROCUTION** hazards. To avoid these hazards, you **MUST** follow requirements for field wiring installation and grounding as described in **NEC** and your local/state/national electrical codes.

### ⚠ WARNING

#### Personal Protective Equipment (PPE) Required!

Failure to wear proper PPE for the job being undertaken could result in death or serious injury.

Technicians, in order to protect themselves from potential electrical, mechanical, and chemical hazards, **MUST** follow precautions in this manual and on the tags, stickers, and labels, as well as the instructions below:

- **Before installing/servicing this unit, technicians MUST put on all PPE required for the work being undertaken (Examples; cut resistant gloves/sleeves, butyl gloves, safety glasses, hard hat/bump cap, fall protection, electrical PPE and arc flash clothing). ALWAYS refer to appropriate Safety Data Sheets (SDS) and OSHA guidelines for proper PPE.**
- **When working with or around hazardous chemicals, ALWAYS refer to the appropriate SDS and OSHA/GHS (Global Harmonized System of Classification and Labelling of Chemicals) guidelines for information on allowable personal exposure levels, proper respiratory protection and handling instructions.**
- **If there is a risk of energized electrical contact, arc, or flash, technicians MUST put on all PPE in accordance with OSHA, NFPA 70E, or other country-specific requirements for arc flash protection, PRIOR to servicing the unit. NEVER PERFORM ANY SWITCHING, DISCONNECTING, OR VOLTAGE TESTING WITHOUT PROPER ELECTRICAL PPE AND ARC FLASH CLOTHING. ENSURE ELECTRICAL METERS AND EQUIPMENT ARE PROPERLY RATED FOR INTENDED VOLTAGE.**

**⚠ WARNING****Follow EHS Policies!**

Failure to follow instructions below could result in death or serious injury.

- All Trane personnel must follow the company's Environmental, Health and Safety (EHS) policies when performing work such as hot work, electrical, fall protection, lockout/tagout, refrigerant handling, etc. Where local regulations are more stringent than these policies, those regulations supersede these policies.
- Non-Trane personnel should always follow local regulations.

**⚠ WARNING****R-454B or R-32 Flammable A2L Refrigerant!**

Failure to use proper equipment or components as described below could result in equipment failure, and possibly fire, which could result in death, serious injury, or equipment damage.

The equipment described in this manual uses R-454B or R-32 refrigerant which is flammable (A2L). Use ONLY R-454B or R-32 rated service equipment and components. For specific handling concerns with R-454B or R-32, contact your local representative.

**⚠ WARNING****Cancer and Reproductive Harm!**

This product can expose you to chemicals including lead and bisphenol A (BPA), which are known to the State of California to cause cancer and birth defects or other reproductive harm. For more information go to [www.P65Warnings.ca.gov](http://www.P65Warnings.ca.gov).

**⚠ WARNING****Electrical Shock Hazard!**

Failure to follow instructions below could result in death or serious injury.

Properly connect the system's oversized protective earthing (grounding) terminal(s).

## Copyright

This document and the information in it are the property of Trane, and may not be used or reproduced in whole or in part without written permission. Trane reserves the right to revise this publication at any time, and to make changes to its content without obligation to notify any person of such revision or change.

## Trademarks

All trademarks referenced in this document are the trademarks of their respective owners.

## Product Safety Information

This appliance is not intended for use by persons (including children) with reduced physical, sensory or mental capabilities, or lack of experience and knowledge, unless they have been given supervision or instruction concerning use of the appliance by a person responsible for their safety. Children should be supervised to ensure that they do not play with the appliance.

Maximum altitude of use 3000 meters.

This appliance incorporates an earth connection for functional purposes only.

## Revision History

- Added Pipe Cabinet – R-32 Installation with a Vertical Unit Vent to the A2L Information and Installation Requirements chapter.
- Added information about R-32 refrigerant.
- Updated Wiring Diagrams table.
- Updated model number description Digit 8 and Digit 30.
- Clarified Hydronic Coil Freeze Protection information for units with R-454B refrigerant.
- Updated A2L Information chapter.



# Table of Contents

|   |    |  |    |
|---|----|--|----|
| Model Number Descriptions . . . . .             | 7  | A2L Work Procedures . . . . .                    | 31 |
| General Information . . . . .                   | 9  | Servicing . . . . .                              | 31 |
| Operating Environment . . . . .                 | 9  | Leak Detection . . . . .                         | 32 |
| Unit Description . . . . .                      | 10 | Refrigerant Removal and                          |    |
| Components . . . . .                            | 10 | Evacuation . . . . .                             | 32 |
| Control Options . . . . .                       | 10 | Refrigerant Charging . . . . .                   | 33 |
| Pre-Installation . . . . .                      | 11 | Decommissioning . . . . .                        | 33 |
| Receiving and Handling . . . . .                | 11 | A2L Application Considerations . . . . .         | 33 |
| Inspection . . . . .                            | 11 | Ignition Sources in Ductwork . . . . .           | 34 |
| Identification . . . . .                        | 11 | Ignition Sources in Unit . . . . .               | 34 |
| Handling . . . . .                              | 11 | Minimum Room Area Limits                         |    |
| Receiving Checklist . . . . .                   | 11 | (Refrigerant charge greater than 3.91 lb         |    |
| Jobsite Storage . . . . .                       | 11 | of R-454B per circuit) . . . . .                 | 34 |
| Site Preparation . . . . .                      | 12 | Minimum Room Area Limits                         |    |
| Dimensions and Weights . . . . .                | 13 | (Refrigerant charge greater than 4.04 lb         |    |
| Service Clearances . . . . .                    | 13 | of R-32 per circuit) . . . . .                   | 34 |
| Component Data . . . . .                        | 13 | Minimum Room Area ( $A_{min}$ )                  |    |
| Installation - Mechanical . . . . .             | 21 | Adjustments . . . . .                            | 36 |
| Installation Checklist . . . . .                | 21 | Determining Room Area (A or TA) . . . . .        | 37 |
| Wall Box Installation . . . . .                 | 21 | Leak Detection System(Refrigerant                |    |
| General Instructions . . . . .                  | 21 | charge greater than 3.91 lb of R-454B            |    |
| Installation in Masonry Walls . . . . .         | 21 | or 4.04 lb of R-32 per circuit) . . . . .        | 37 |
| Installation in Curtain Walls . . . . .         | 22 | Field Piping Installation and Charging . . . . . | 38 |
| Installing the Unit . . . . .                   | 22 | Pipe Cabinet – R-32 Installation with a          |    |
| Subbase (Option) . . . . .                      | 24 | Vertical Unit Vent . . . . .                     | 39 |
| Coil Piping and Connections . . . . .           | 25 | Installation - Controls . . . . .                | 40 |
| Coil Piping and Connections . . . . .           | 25 | Control Options . . . . .                        | 40 |
| Piping Packages . . . . .                       | 25 | Fan Speed Control with Standard                  |    |
| Valve and Actuator Operation . . . . .          | 27 | Adapter Board . . . . .                          | 40 |
| Valve Stroke Time . . . . .                     | 27 | Customer Supplied Terminal Interface             |    |
| Balancing Manual Circuit Setter Valve . . . . . | 28 | (CSTI) . . . . .                                 | 40 |
| Split System Piping . . . . .                   | 28 | Symbio™ 400-B Controller . . . . .               | 43 |
| Refrigerant Piping . . . . .                    | 28 | Communication Wire                               |    |
| Steam Piping . . . . .                          | 29 | Specifications . . . . .                         | 43 |
| A2L Information and Installation                |    | General Wiring Guidelines . . . . .              | 43 |
| Requirements . . . . .                          | 31 | Setting the Address . . . . .                    | 44 |
| Installation/Code Compliance                    |    | Power Supply . . . . .                           | 44 |
| Requirements . . . . .                          | 31 | Transformer Recommendations . . . . .            | 45 |
|   |    | Wiring Requirements . . . . .                    | 45 |
|   |    | Connecting Wires . . . . .                       | 45 |
|   |    | Power ON Check . . . . .                         | 45 |
|   |    | Air-Fi® Wireless Communications                  |    |
|   |    | System . . . . .                                 | 46 |
|   |    | Air-Fi® Wireless Communications                  |    |
|   |    | Interface (WCI) . . . . .                        | 46 |

|  |    |   |    |
|--|----|---|----|
| Air-Fi® Wireless Communications          |    | Lock Symbol . . . . .                     | 58 |
| Sensor (WCS) . . . . .                   | 46 | Testing Signal Strength . . . . .         | 58 |
| Wireless Zone Sensor (WZS) Set . . . . . | 46 | Testing Battery Status . . . . .          | 58 |
| Zone Sensor Options . . . . .            | 47 | Time Clock . . . . .                      | 58 |
| Zone Sensor Installation . . . . .       | 48 | Setting the Time Clock . . . . .          | 58 |
| Location Considerations . . . . .        | 48 | Installation – Electrical . . . . .       | 61 |
| Location Considerations for Wireless     |    | Electrical Wiring . . . . .               | 61 |
| Zone Sensors . . . . .                   | 48 | Electric Heat . . . . .                   | 62 |
| Height Requirements . . . . .            | 48 | DX Split System . . . . .                 | 62 |
| Mounting Surfaces . . . . .              | 48 | Split System Start-Up . . . . .           | 63 |
| Zone Sensor Dimensions . . . . .         | 49 | ECM Overview and Setup . . . . .          | 64 |
| Wired Zone Sensor . . . . .              | 49 | Overview . . . . .                        | 64 |
| Wireless Zone Sensors . . . . .          | 50 | Electronically Commutated Motor           |    |
| Receivers . . . . .                      | 50 | (ECM) . . . . .                           | 64 |
| Zone Sensor Setting . . . . .            | 50 | VelociTach™ Motor Control Board . . . . . | 65 |
| Address Setting . . . . .                | 50 | Status Display . . . . .                  | 65 |
| Observing the Receiver for Readiness     |    | Installation and Initial Setup . . . . .  | 65 |
| to Associate . . . . .                   | 51 | Safety Requirements . . . . .             | 66 |
| Associating the Sensor to the            |    | Setup . . . . .                           | 66 |
| Receiver . . . . .                       | 51 | VelociTach™ Motor Control Board . . . . . | 66 |
| Testing Signal Strength and Battery      |    | User Interface . . . . .                  | 67 |
| Status . . . . .                         | 52 | Priority/Error Display . . . . .          | 69 |
| Sensor Operations . . . . .              | 53 | Adjustments . . . . .                     | 70 |
| Temporary Occupancy (Timed               |    | Adjusting Variable Speed Inputs . . . . . | 70 |
| Override) . . . . .                      | 53 | Adjusting Optional Auto-Changeover        |    |
| End-of-Range Temperature                 |    | Function on CSTI Units . . . . .          | 72 |
| Values . . . . .                         | 53 | Configurations . . . . .                  | 73 |
| Receiver Power-up Sequence . . . . .     | 53 | Motor Control Board Settings . . . . .    | 73 |
| Transmission Variables . . . . .         | 53 | Fan Speed Response Verification . . . . . | 76 |
| Wireless Sensor Specifications . . . . . | 54 | Start-Up . . . . .                        | 78 |
| Agency Compliance . . . . .              | 54 | Pre-Start-Up Checklist . . . . .          | 78 |
| Configuring the Wireless Display Sensor  |    | General Checks . . . . .                  | 78 |
| (Model WDS only) . . . . .               | 54 | Fan-Related . . . . .                     | 78 |
| Configuration Procedure . . . . .        | 54 | Coil-Related Checks . . . . .             | 78 |
| Displaying Setpoint or                   |    | Electrical Checks . . . . .               | 78 |
| Temperature . . . . .                    | 56 | Ductwork Checks . . . . .                 | 78 |
| Locking or Unlocking Settings . . . . .  | 56 | Unit Start-Up . . . . .                   | 79 |
| WDS Operating Mode . . . . .             | 56 | Fan Speed Control . . . . .               | 79 |
| Changing Room Temperature . . . . .      | 57 | Fan Mode Switch Operation . . . . .       | 79 |
| Changing Heating and Cooling Room        |    | Symbio™ 400-B Controller . . . . .        | 79 |
| Temperature Settings . . . . .           | 57 |   |    |
| Changing the Fan Setting . . . . .       | 57 |   |    |
| Requesting Temporary                     |    |   |    |
| Occupancy . . . . .                      | 58 |   |    |
| Error Codes . . . . .                    | 58 |   |    |



## Table of Contents

---

|  |    |   |     |
|--|----|---|-----|
| Symbio™ 400-B Stand-Alone Operation . . . . .  | 79 | 24 V Power Status Indicator . . . . .                             | 98  |
| Symbio™ 400-B Operation . . . . .              | 79 | Check Signal Strength on a Site . . . . .                         | 98  |
| Sequence of Operation . . . . .                | 79 | Replacing Sensor Batteries . . . . .                              | 99  |
| Occupancy Modes . . . . .                      | 80 | Manual Association . . . . .                                      | 99  |
| Timed Override Control . . . . .               | 80 | Disassociation . . . . .  | 100 |
| Zone Temperature Control . . . . .             | 81 | Sensor/Receiver Compatibility . . . . .                           | 100 |
| Discharge Air Tempering . . . . .              | 81 | Replacing a Failed Sensor or Receiver . . . . .                   | 100 |
| Heating or Cooling Mode . . . . .              | 81 | Servicing and Testing WZS . . . . .                               | 100 |
| Fan Operation . . . . .                        | 82 | Servicing and Testing Tools . . . . .                             | 100 |
| Exhaust Control . . . . .                      | 82 | Procedure for Testing Zone Sensor . . . . .                       | 100 |
| Valve Operation . . . . .                      | 83 | Procedure for Testing Receiver . . . . .                          | 100 |
| Modulating Outdoor/Return Air Damper . . . . . | 83 | Forcing a Sensor to Transmit . . . . .                            | 100 |
| Electric Heat Operation . . . . .              | 84 | Output Power Level . . . . .                                      | 100 |
| Dehumidification Operation . . . . .           | 84 | Failure and Default Modes . . . . .                               | 101 |
| Peer-to-Peer Communication . . . . .           | 85 | Measuring Output Resistance . . . . .                             | 101 |
| Unit Protection Strategies . . . . .           | 85 | Symbio™ 400-B Controller . . . . .                                | 101 |
| Maintenance . . . . .                          | 87 | LED Activity . . . . .  | 101 |
| Maintenance Checklist . . . . .                | 87 | Overriding Outputs . . . . .                                      | 103 |
| Service Access . . . . .                       | 87 | Diagnostics . . . . .   | 103 |
| Air Filters . . . . .                          | 88 | Diagnostics Types . . . . .                                       | 103 |
| Drain Pan/Fan/Motor Board Assembly . . . . .   | 88 | Fans with Symbio™ 400-B Controller . . . . .                      | 105 |
| Cleaning Drain Pan . . . . .                   | 89 | Valves with Symbio™ 400-B Controller . . . . .                    | 106 |
| Inspecting and Cleaning Fans . . . . .         | 89 | DX Coils or Electric Heat with Symbio™ 400-B Controller . . . . . | 106 |
| Torque Rating . . . . .                        | 90 | Outdoor Air Dampers with Symbio™ 400-B Controller . . . . .       | 107 |
| Coil Cleaning . . . . .                        | 91 | ECM Motors . . . . .  | 108 |
| Steam and Water Coils . . . . .                | 91 | General Information . . . . .                                     | 108 |
| Refrigerant Coils . . . . .                    | 92 | Troubleshooting Tips . . . . .                                    | 108 |
| Moisture Purge Cycle . . . . .                 | 92 | Motor . . . . .   | 108 |
| Cleaning Non-Porous Surfaces . . . . .         | 92 | Replacing ECM Components . . . . .                                | 110 |
| Cleaning Porous Surfaces . . . . .             | 93 | Circuit Module Replacement . . . . .                              | 111 |
| Diagnostics and Troubleshooting . . . . .      | 94 | Application Notes . . . . .                                       | 112 |
| Wireless Zone Sensors (WZS) . . . . .          | 95 | Wiring Diagrams . . . . .   | 114 |
| Receiver Diagnostics . . . . .                 | 96 |   |     |
| Sensor Diagnostics . . . . .                   | 96 |   |     |
| Testing Signal Strength . . . . .              | 97 |   |     |
| Testing Battery Status . . . . .               | 98 |   |     |



# Model Number Descriptions

## Digit 1, 2, 3 — Unit Model

VUV = Vertical Unit Ventilator

## Digit 4 — Development Sequence

E = 5th development sequence

## Digit 5, 6, 7— Nominal Airflow

075 = 750 cfm  
100 = 1000 cfm  
125 = 1250 cfm  
150 = 1500 cfm

## Digit 8 — Voltage/Hz/Phase

0 = 115/60/1  
1 = 208/60/1  
2 = 230/60/1  
3 = 208/60/3  
4 = 460/60/3  
7 = 277/60/1  
8 = 230/60/3

## Digit 9 — Open Digit

0 = Standard design  
S = Special

## Digit 10, 11 — Current Design Sequence

\*\*\* = Factory assigned

## Digit 12 — Face-and-Bypass Damper

Y = Yes, includes damper  
N = No damper

## Digit 13 — Inlet Arrangement

1 = Return air front/fresh air back  
2 = 100% return air front  
3 = 100% fresh air back  
4 = Dynamic air barrier  
5 = Energy recovery system (ERS)-compatible with RH connection  
6 = Energy recovery system (ERS)-compatible with LH connection

## Digit 14 — Preheat/Reheat/Changeover Coil

A = 4-pipe preheat coil (RH cooling/LH heating)  
B = 4-pipe preheat coil (LH cooling/RH heating)  
C = 4-pipe reheat coil (RH cooling/LH heating)  
D = 4-pipe reheat coil (LH cooling/RH heating)  
E = 2-pipe coil (RH connections)  
F = 2-pipe coil (LH connections)

## Digit 15 — Cooling/Changeover Coil

0 = No cooling/changeover coil  
B = 2-row low capacity cooling/ changeover /dual purpose coil  
C = 2-row high capacity cooling/ changeover /dual purpose coil  
D = 3-row low capacity cooling/ changeover /dual purpose coil  
E = 3-row high capacity cooling/ changeover /dual purpose coil  
F = 4-row low capacity cooling/ changeover /dual purpose coil  
G = 4-row high capacity cooling/ changeover /dual purpose coil  
H = EarthWise™ cooling/ changeover /dual purpose coil  
J = DX cooling coil  
T = DX cooling coil with VRF application

## Digit 16 — Heating Coil

0 = None  
A = 1-row heating  
B = 2-row low capacity  
C = 2-row high capacity  
D = 3-row low capacity  
E = 3-row high capacity  
F = 4-row low capacity  
G = 4-row high capacity  
H = EarthWise™ heating coil  
K = Steam heating - low capacity  
L = Steam heating - high capacity  
M = Electric heat - low capacity

## Digit 17 — Motor

0 = Electronically Commutated Motor (ECM)  
1 = ECM and low acoustic option  
2 = ECM and low FLA option  
3 = ECM and low acoustic and low FLA option

## Digit 18 — Other Motor Items

B = Toggle  
C = Circuit breaker

## Digit 19 — Cooling/Changeover Valve Type

0 = None  
A = 2-way, 2 position N.C.  
B = 2-way, 2 position N.O.  
C = 3-way, 2 position N.C.  
D = 3-way, 2 position N.O.  
E = 2-way, modulating  
F = 3-way, modulating  
G = 2-way, analog (2 to 10 Vdc)  
H = 3-way, analog (2 to 10 Vdc)  
J = Field supplied, 2 position N.C.  
K = Field supplied, 2 position N.O.  
L = Field supplied, modulating  
M = Field supplied, analog (2 to 10 Vdc)

## Digit 20 — Cv Cooling/Changeover Valve

0 = None  
A = 2-way 2.3 Cv  
B = 2-way 3.3 Cv  
C = 2-way 4.6 Cv  
D = 2-way 6.6 Cv  
E = 3-way 2.7 Cv  
F = 3-way 4.6 Cv  
G = 3-way 7.4 Cv

## Digit 21 — Heating Valve Type

0 = None  
A = 2-way, 2 position N.C.  
B = 2-way, 2 position N.O.  
C = 3-way, 2 position N.C.  
D = 3-way, 2 position N.O.  
E = 2-way, modulating  
F = 3-way, modulating  
G = 2-way, analog (2 to 10 Vdc)  
H = 3-way, analog (2 to 10 Vdc)  
J = Field supplied, 2 position N.C.  
K = Field supplied, 2 position N.O.  
L = Field supplied, modulating  
M = Field supplied, analog (2 to 10 Vdc)

## Digit 22 — Cv Heating Valve

0 = None  
A = 2-way 1.4 Cv  
B = 2-way 2.4 Cv  
C = 2-way 3.4 Cv  
D = 2-way 4.8 Cv  
E = 2-way 5.9 Cv  
F = 3-way 2.7 Cv  
G = 3-way 4.6 Cv  
N = 3-way 7.4 Cv  
J = Steam 1.8 Cv  
K = Steam 4.6 Cv  
P = Steam 7.3 Cv



## Model Number Descriptions

### Digit 23 — Discharge Arrangement

- 0 = Opening only, no grille
- A = Grille discharge
- B = Double deflection discharge grille
- C = Grille discharge with wire mesh

### Digit 24 — Outside Air Damper Control

- 0 = None
- A = 3-wire actuator
- B = 2–10 volt actuator

### Digit 25 — Face-and-Bypass Damper Control

- 0 = None
- A = 3-wire actuator
- B = 2–10 volt actuator

### Digit 26 — Controls

- 2 = Customer supplied terminal interface (CSTI)
- 3 = CSTI with low temperature detection
- E = Symbio™ 400-B controller
- F = Symbio™ 400-B with time clock
- G = Symbio™ 400-B with Air-Fi® WCI
- N = CSTI fan status

### Digit 27 — Unit- or Wall-Mounted Controls

- 0 = None
- 1 = Unit-mounted
- 2 = Wall-mounted
- 3 = Combined unit-mounted and wallmounted sensor
- 4 = Wireless zone sensor

### Digit 28 — Internal or External Set Point

- 0 = None
- 2 = External
- 3 = Digital display

### Digit 29 — Timed Override

- 0 = No timed override
- 1 = Yes, Timed override

### Digit 30 — Refrigerant Types

- 0 = No refrigerant
- 1 = R-410A replacements only
- 2 = R-454B
- 3 = R-32

### Digit 31 — Programming Options

- 0 = None
- 1 = Humidity sensor programming
- 2 = CO<sub>2</sub> sensor programming
- 3 = Air-Fi® Humidity Sensor and CO<sub>2</sub>
- 4 = Air-Fi® Humidity Sensor
- 5 = Air-Fi® CO<sub>2</sub>

### Digit 32 — Depth

- A = 16.63 in. standard depth
- B = 21.25 in. depth with baffle
- C = 21.25 in. depth with full sheet metal back with baffle
- D = 21.25 in. depth with 25 in. high falseback
- E = 221.25 in. depth with 26 in. high falseback
- F = 21.25 in. depth with 27 in. high falseback
- G = 21.25 in. depth with 28 in. high falseback
- H = 21.25 in. depth with 29 in. high falseback
- J = 21.25 in. depth without baffle

### Digit 33 — End Covers

- 0 = No decorative end covers
- 1 = 16.63 in. depth without cutout
- 2 = 16.63 in. depth with standard cutout
- 3 = 16.63 in. depth with extended cutout
- 4 = 21.25 in. depth without cutout
- 5 = 21.25 in. depth with standard cutout
- 6 = 21.25 in. depth with extended cutout

### Digit 34 — Front Panel or Access Panel

- 1 = Standard front panel
- 2 = Insulated front panel

### Digit 35 — Sub-base

- 0 = No sub-base
- 1 = 2 in. sub-base
- 4 = 4 in. sub-base
- 6 = 6 in. sub-base

### Digit 36 — Piping Package

- 0 = None
- 4 = Basic -ball valve supply and return
- 5 = Basic - ball valve supply and manual circuit setter return
- 6 = Deluxe - ball valve supply and manual circuit setter return
- 7 = Deluxe - ball valve supply and return with auto flow

### Digit 37 — Cooling/Changeover Auto Flow GPM

- 0 = None
- A = 4.0
- B = 4.5
- C = 5.0
- D = 6.0
- E = 6.5
- F = 7.0
- G = 8.0

### Digit 38 — Heating Auto Flow GPM

- 0 = None
- A = 1.0
- B = 1.5
- C = 2.0
- D = 2.5
- E = 3.0
- F = 3.5
- G = 4.0
- H = 4.5
- J = 5.0
- K = 6.0

### Digit 39 — Auxiliary Drain Pan

- Y = Yes, auxiliary drain pan
- N = No auxiliary drain pan

### Digit 40 — Crossover Piping

- 0 = No crossover piping
- 1 = Internal crossover
- 2 = External 1 3/8 in. crossover piping
- 3 = External 2 1/8 in. crossover piping

### Digit 41 — Filter

- 1 = Standard throwaway filter
- 2 = Merv 8 filter
- 3 = Merv 13 filter

### Digit 42 — Cabinet Color

- 1 = Standard deluxe beige
- 2 = Cameo white
- 3 = Soft dove
- 4 = Stone gray
- 5 = Driftwood gray



# General Information

Academic performance of U.S. students depends, in part, on the ability to create a comfortable, learning-friendly surrounding. Being too hot or too cold could hinder students ability to achieve academic excellence.

Seasonal changes, mechanical/building disrepair, and even class attendance provide real challenges to HVAC mechanical systems. The only thing consistent about

today's classroom is its ability to constantly change. With this in mind, Trane's classroom unit ventilator is designed to support today's changing environment. Its blow-thru design provides freeze protection, sound attenuation, and safety. It has sealed coil which can be quickly accessed for cleaning and visual inspection.

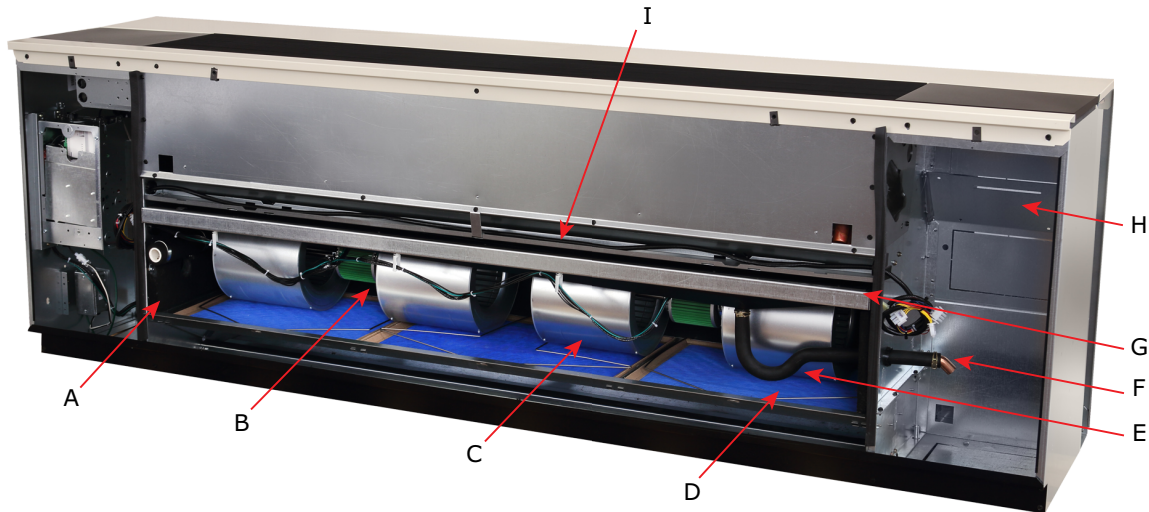

| Element | Description  |
|---------|--|
| A       | Linkage-free outside air damper                                  |
| B       | Maintenance free EC motor with direct-drive fans                 |
| C       | Larger fans for lower sound levels                               |
| D       | Off-the-shelf filters  |
| E       | P-trap   |
| F       | Hassle-free piping   |
| G       | Drain pan/fan/motor board assembly slides out for easy access    |
| H       | Roomy end pockets for easy installation and system customization |
| I       | Drain pan  |

Figure 1. Back view of unit ventilator



## Operating Environment

Locate unit in an indoor area. The ambient temperature surrounding the unit must not be less than 45°F. Do not locate the unit in areas subject to freezing.



## NOTICE

### Equipment Damage!

Failure to protect the unit from freezing could result in equipment damage.

If fluid has been added to the piping, the unit must be protected from freezing. Freeze damage from an unheated equipment room is not the Trane company's responsibility. These are indoor units.

## Unit Description

Before shipment, each unit is leak-tested and run-tested for proper control operation.

### Components

A three-panel front access of the unit ventilator allows for speedy set-up during field commissioning. This design allows for the end pocket of the unit ventilator to be open while the fan (airside) section stays closed. Access for piping and controls is made through the unit ventilator's end pockets.

The drain pan is dual-sloped for effective condensate removal. It is made from a non-corrosive material to help eliminate issues associated to leaking or standing water. It may be easily removed for cleaning. The drain pan connection size for all Trane VUVE models is 7/8 in. OD.

Motors for the VUVE model do not include an external fan bearing on the end of the fan shaft. This helps avoid issues related to fan bearing maintenance (oiling is not needed), and/or bearing replacement.

Filter sizing for the unit ventilator are an off-the-shelf design to reduce or help eliminate local stocking of the filters. Options include throwaway filters, MERV 8, and MERV 13 filters.

Convenient access to the fan motor and wheels for maintenance and serviceability may be made through Trane's easy-slide fan deck design.

**Note:** *Ground wire must be reconnected if removed for service of fan deck.*

The outside air/return air damper is a one piece, linkage free design resulting in a superior air-tight seal.

### Control Options

Trane unit ventilators are available with a variety of control options, including factory-mounted controls and customer-supplied terminal interface (CSTI).



## Pre-Installation

### ⚠ WARNING

#### Hazardous Voltage w/Capacitors!

Failure to disconnect power and discharge capacitors before servicing could result in death or serious injury.

Disconnect all electric power, including remote disconnects and discharge all motor start/run capacitors before servicing. Follow proper lockout/tagout procedures to ensure the power cannot be inadvertently energized. Verify with a CAT III or IV voltmeter rated per NFPA 70E that all capacitors have discharged.

## Receiving and Handling

### Inspection

Upon delivery, thoroughly inspect all components for any shipping damage that may have occurred, and confirm that the shipment is complete. See receiving checklist section for detailed instructions.

**Note:** *Equipment is shipped FOB (Free on Board) at the manufacturer. Therefore, freight claims for damages against the carrier must be initiated by the receiver.*

### Identification

The unit nameplate is located in the left-hand end pocket, behind the control box. It includes the unit model number, serial number, electrical characteristics, and other pertinent unit data. If specified, the unit will ship with tagging designated by the customer.

### Handling

Trane recommends leaving units and accessories in their shipping packages/skids for protection and handling ease until installation. Remove the skids before placing the unit in its permanent location.

To remove the skid, remove shipping bracket from the lower rear corners of the unit and shipping skid. Access to the screws holding unit to the skid is obtained inside the unit.

Figure 2. Shipping skid removal

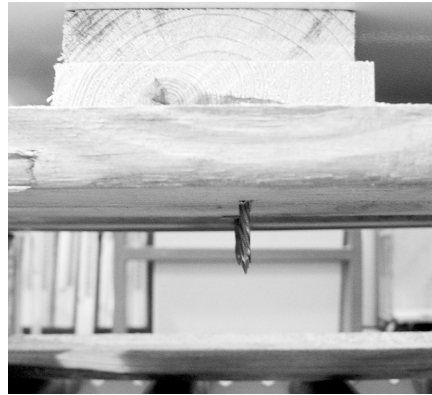

### Receiving Checklist

Complete the following checklist immediately after receiving shipment to detect possible shipping damage.

- Check to ensure that the shipment is complete. Small components may ship inside the unit or ship separately. Check the parts list to ensure all materials are present.
- Check all units, components, connections, and piping. Check fan wheel for free rotation by spinning manually. Check all doors, latches and hinges. Inspect interior of each unit or section. Inspect coils for damage to fin surface and coil connections. Check for rattles, bent corners, or other visible indications of shipping damage. Tighten loose connections.
- If a unit is damaged, make specific notations concerning the damage on the freight bill. Do not refuse delivery.
- Notify the carrier's terminal of the damage immediately by phone and mail. Request an immediate joint inspection of the damage by the carrier and consignee.
- Notify your Trane sales representative of the damage and arrange for repair.
- Inspect the unit for concealed damage as soon as possible after delivery. Report concealed damage to the freight line. It is the receiver's responsibility to provide reasonable evidence that concealed damage did not occur after delivery. Take photos of damaged material if possible.

**Note:** *Concealed damage must be reported within 15 days of receipt.*

### Jobsite Storage

This unit is intended for indoor use only. It is the sole responsibility of the customer to provide the necessary protection to prevent vandalism and weather protection of the equipment. Under no circumstance should the unit be left unprotected from the elements.

**NOTICE****Microbial Growth!**

Failure to follow instructions below could result in odors and damage to the equipment and building materials.

The floor or foundation must be level and the condensate drain at the proper height for proper drainage and condensate flow. Standing water and wet surfaces inside the equipment can become an amplification site for microbial growth (mold). If there is evidence of microbial growth on the interior insulation, it should be removed and replaced prior to operating the system.

If indoor storage is not possible, Trane makes the following recommendations to prevent damage:

**Note:** *Keep the equipment on the original wooden blocks/skid for protection and ease of handling.*

- Select a well-drained area, preferably a concrete pad or blacktop surface.
- Place the unit on a dry surface or raised off the ground to assure adequate air circulation beneath the unit and to assure no portion of the unit will contact standing water at any time.
- Cover the unit securely with a canvas tarp.

**NOTICE****Unit Corrosion Damage!**

Plastic tarps can cause condensation to form in and on the equipment, which could result in corrosion damage or wet storage stains. Use only canvas tarps to cover equipment.

- Do not stack units.
- Do not pile other material on the unit.

**Site Preparation****⚠ WARNING****Heavy Object!**

Inadequate structural support could result in unit falling, which could result in death or serious injury. Verify floor structure can support the unit weight. Consult the structural plans, and have a structural engineer confirm floor rating is sufficient.

- Ensure the installation site can support the total weight of the unit while allowing for openings in the floor for a return air duct, electrical, and piping supply lines fed through the floor. See “Dimensions and Weights,” p. 13 for approximate section weights; refer to the unit submittals for actual weights.
- Allow sufficient space for necessary service access. Internal access to the unit is provided by the removable front panel. Sufficient space should be allowed to lift the

panel for maintenance purposes (see “Dimensions and Weights,” p. 13). Refer to submittals for specific minimums.

**NOTICE****Microbial Growth!**

Failure to follow instructions below could result in odors and damage to the equipment and building materials.

The floor or foundation must be level and the condensate drain at the proper height for proper drainage and condensate flow. Standing water and wet surfaces inside the equipment can become an amplification site for microbial growth (mold). If there is evidence of microbial growth on the interior insulation, it should be removed and replaced prior to operating the system.

- Confirm the floor or foundation is level. For proper unit operation, the unit must be level (zero tolerance) in both horizontal axis.

**Note:** *The unit leveling legs can be adjusted to accommodate slight out-of-level installation surfaces.*

- Wall space design should allow the unit to be mounted to the wall securely. The wall surface behind the unit should be smooth and level. Wall and floor moldings should be removed prior to installation. A wall slightly out of level may cause problems with unconditioned air leaking into the room. Remove any object projecting more than 1/8 in. from the wall surface.

**Note:** *Additional gasket or furr strips may be installed to accommodate for an uneven wall.*

- There are two removable knock-outs in the rear of the unit, on either end, for piping and electrical supply lines. A pipe chase is located in the upper back portion of the unit for crossover piping. The outside air opening is located in the lower back of the unit and the path to the wallbox on the outside wall should be unobstructed.
- The physical layout of the room should accommodate any accessories ordered with the unit. Conditioned air is distributed through the grille on top of the unit and returned through the return air grille on the bottom of the unit. Avoid placing any objects that may obstruct either grille or interfere with airflow.



# Dimensions and Weights

## Service Clearances

Attention should be given to service clearance and technician safety. The unit should contain enough space for service personnel to perform maintenance or repair. Provide sufficient room to make water, and electrical connection(s). A 36-inch clearance at the unit front is sufficient for maintenance and service of the equipment.

**Note:** For electric heat, the minimum clearance from the appliance to combustible surfaces is 0 inches.

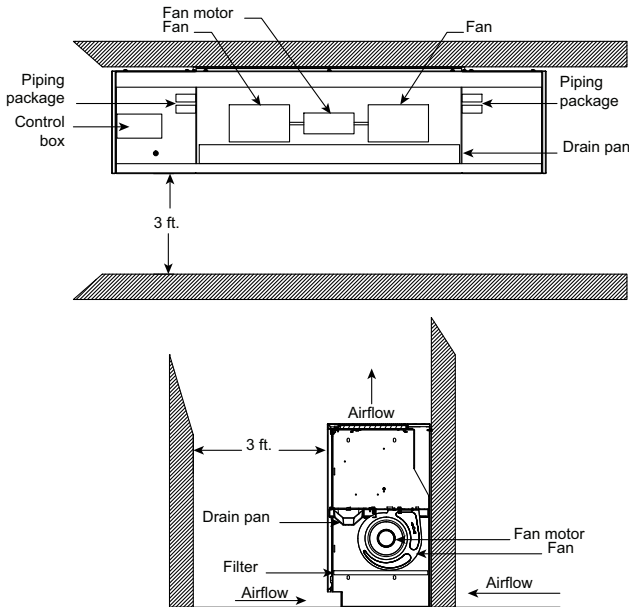

**⚠ WARNING**

**Proper Field Wiring and Grounding Required!**

Failure to follow code could result in death or serious injury.

All field wiring **MUST** be performed by qualified personnel. Improperly installed and grounded field wiring poses **FIRE** and **ELECTROCUTION** hazards. To avoid these hazards, you **MUST** follow requirements for field wiring installation and grounding as described in NEC and your local/state/national electrical codes.

## Component Data

**Table 1. Vertical unit ventilator general data**

| Description  | Unit size       |                                    |                                    |                                    |
|--|-----------------|------------------------------------|------------------------------------|------------------------------------|
|  | 0750            | 1000                               | 1250                               | 1500                               |
| Unit length without end covers (in.)               | 69.00           | 81.00                              | 93.00                              | 105.00                             |
| Unit depth - standard (in.)                        | 16 5/8          | 16 5/8                             | 16 5/8                             | 16 5/8                             |
| Unit depth - with false back (in.)                 | 21 1/4          | 21 1/4                             | 21 1/4                             | 21 1/4                             |
| Unit height - standard (in.)                       | 30.00           | 30.00                              | 30.00                              | 30.00                              |
| Shipping weight (lb)                               | 320             | 405                                | 450                                | 470                                |
| Nominal filter size (in.) and quantity             | 14 x 20 x 1 (2) | 14 x 24 x 1 (1)<br>14 x 30 x 1 (1) | 14 x 20 x 1 (2)<br>14 x 24 x 1 (1) | 14 x 24 x 1 (2)<br>14 x 30 x 1 (1) |
| Dynamic air filter nominal size (in.) and quantity | 7 x 42 x 1 (1)  | 7 x 54 x 1 (1)                     | 7 x 66 x 1 (1)                     | 7 x 78 x 1 (1)                     |
| Drain connection size (in.)                        | 7/8-in. I.D.    | 7/8-in. I.D.                       | 7/8-in. I.D.                       | 7/8-in. I.D.                       |
| Fan type / quantity                                | FC / 2          | FC / 2                             | FC / 4                             | FC / 4                             |
| Motor data - quantity/horsepower                   | 1 - 1/4         | 1 - 1/4                            | 2 - 1/4                            | 2 - 1/4                            |
| <b>Coil volume (gal)</b>                           |                 |                                    |                                    |                                    |
| Coil type A  | 0.18            | 0.23                               | 0.28                               | 0.33                               |

## Dimensions and Weights

**Table 1. Vertical unit ventilator general data (continued)**

| Description | Unit size |      |      |      |
|-------------|-----------|------|------|------|
|             | 0750      | 1000 | 1250 | 1500 |
| Coil type B | 0.31      | 0.41 | 0.51 | 0.61 |
| Coil type C | 0.31      | 0.41 | 0.51 | 0.61 |
| Coil type D | 0.44      | 0.57 | 0.70 | 0.93 |
| Coil type E | 0.44      | 0.57 | 0.70 | 0.93 |
| Coil type F | 0.61      | 0.81 | 1.01 | 1.21 |
| Coil type G | 0.61      | 0.81 | 1.01 | 1.21 |
| Coil type H | 0.40      | 0.59 | 0.74 | 0.84 |

**Table 2. Control methodology**

| Method        | Fan Speeds                   |
|---------------|------------------------------|
| CSTI          | 3 or infinite <sup>(a)</sup> |
| Symbio™ 400-B | Infinite                     |

<sup>(a)</sup> With a field-supplied 2-10 Vdc controller.

**Table 3. Control sequences**

| Sequence                               | Fan Speeds |
|--|------------|
| DX operation <sup>(a)</sup>            | 1          |
| Electric heat operation <sup>(a)</sup> | 1          |

<sup>(a)</sup> Fan speed during sequence operation.

Figure 3. Standard depth unit

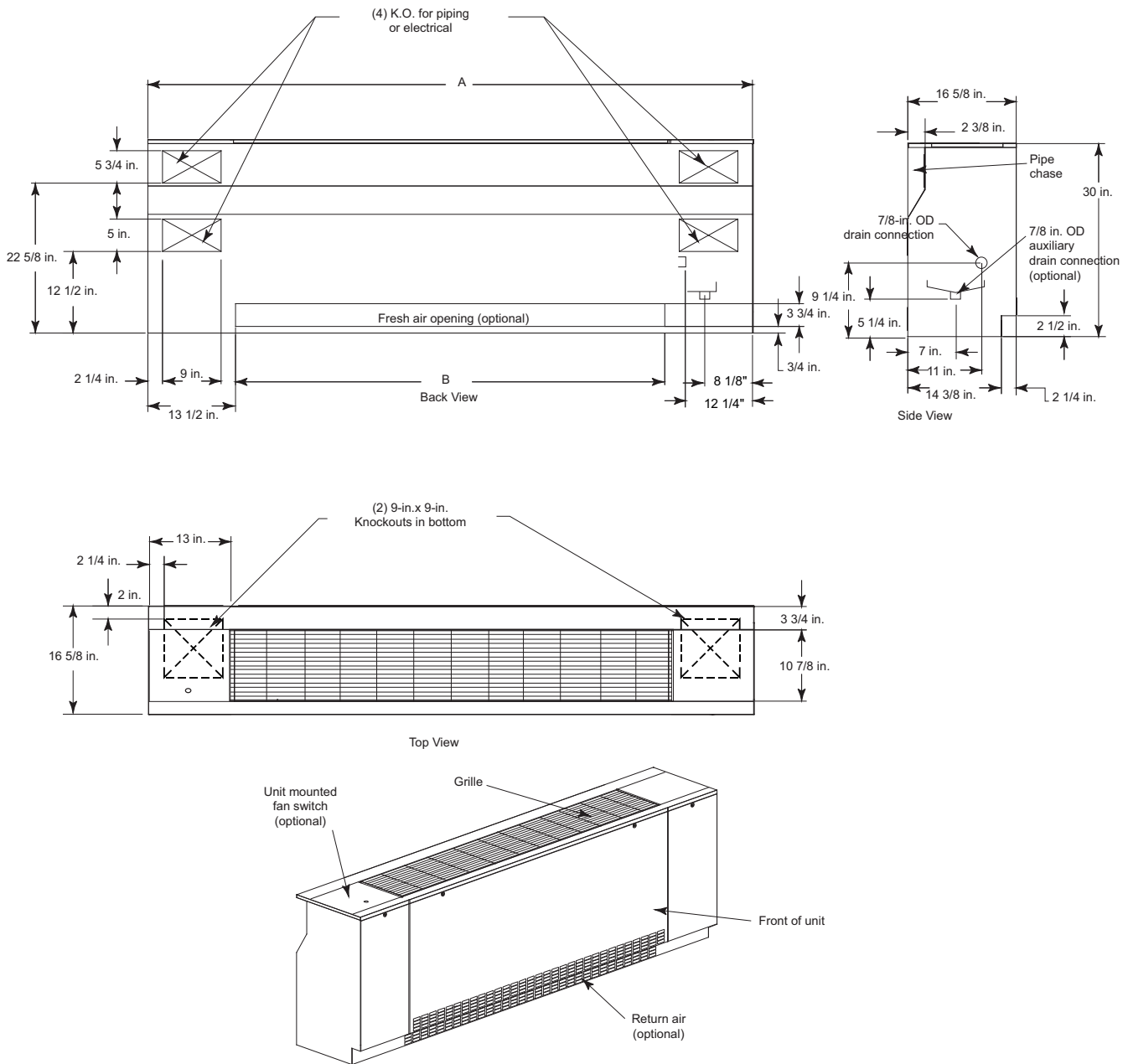

Table 4. Standard unit depth (inches)

| Unit size | No. of fans | A  | B  |
|-----------|-------------|----|----|
| 075       | 2           | 69 | 42 |
| 100       | 2           | 81 | 54 |
| 125       | 4           | 93 | 66 |

Table 4. Standard unit depth (inches) (continued)

| Unit size | No. of fans | A   | B  |
|-----------|-------------|-----|----|
| 150       | 4           | 105 | 78 |

**Note:** Unit length does not include 5/8-inch end panels. Power connection is made in the left hand end pocket for all options but electric heat. Power connection for electric heat option is made in the right hand end pocket.

**Figure 4. Falseback unit**

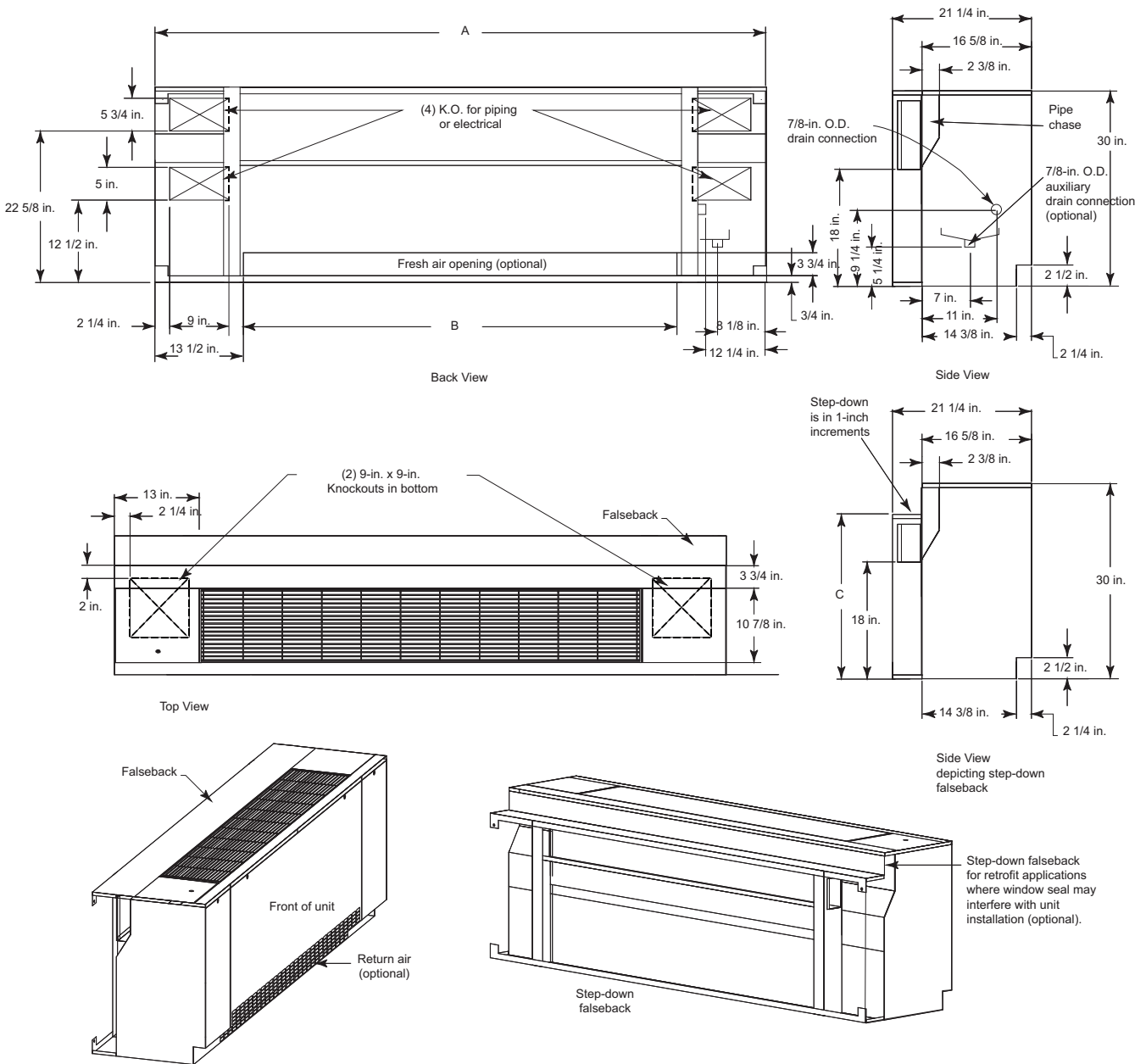

**Table 5. Falseback unit depth (inches)**

| Unit size | No. of fans | A  | B  | C     |
|-----------|-------------|----|----|-------|
| 075       | 2           | 69 | 42 | 25–29 |
| 100       | 2           | 81 | 54 | 25–29 |
| 125       | 4           | 93 | 66 | 25–29 |

**Table 5. Falseback unit depth (inches) (continued)**

| Unit size | No. of fans | A   | B  | C     |
|-----------|-------------|-----|----|-------|
| 150       | 4           | 105 | 78 | 25–29 |

**Note:** Unit length does not include 5/8-inch end panels. Power connection is made in the left hand end pocket for all options but electric heat. Power connection for electric heat option is made in the right hand end pocket.

Figure 5. Dynamic air barrier unit

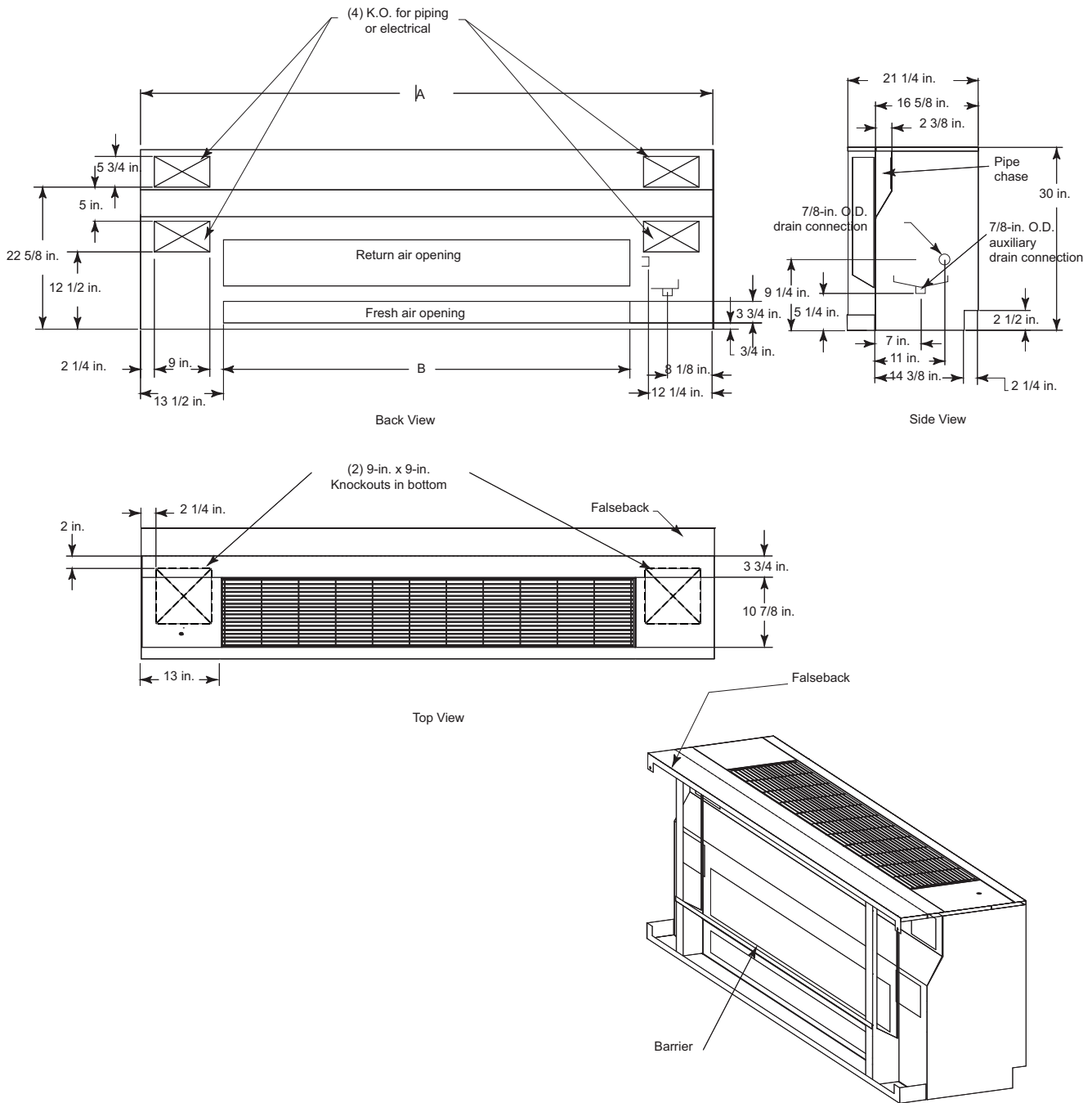

Table 6. Dynamic air barrier (inches)

| Unit size | No. of fans | A  | B  |
|-----------|-------------|----|----|
| 075       | 2           | 69 | 42 |
| 100       | 2           | 81 | 54 |
| 125       | 4           | 93 | 66 |

Table 6. Dynamic air barrier (inches) (continued)

| Unit size | No. of fans | A   | B  |
|-----------|-------------|-----|----|
| 150       | 4           | 105 | 78 |

**Note:** Unit length does not include 5/8-inch end panels. Power connection is made in the left hand end pocket for all options but electric heat. Power connection for electric heat option is made in the right hand end pocket.

# Dimensions and Weights

**Figure 6. End covers**

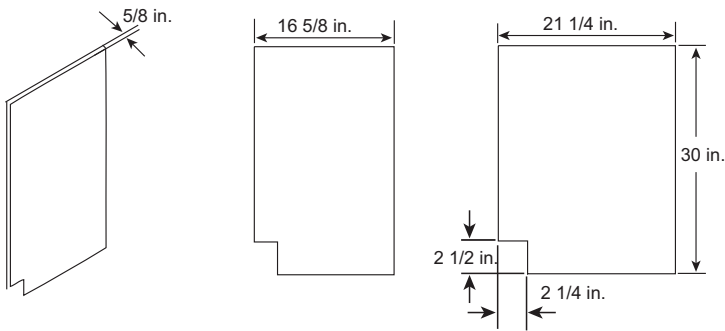

End covers without cutouts

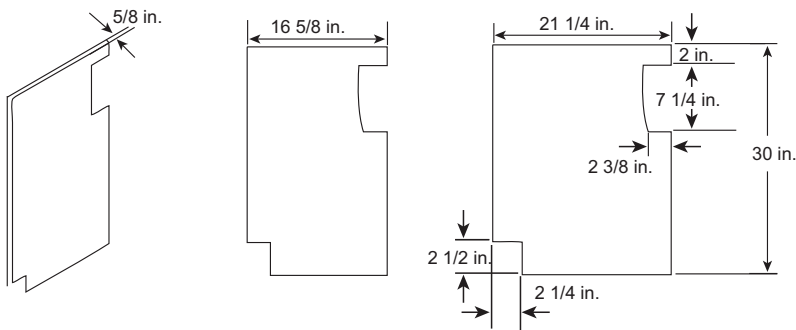

End covers with 7 1/4 in. cutouts for 2-pipe applications

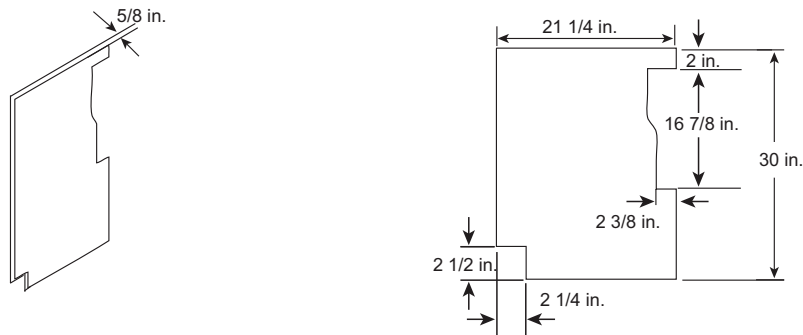

End cover with 16 7/8 in. cutouts for 4-pipe, dynamic air, and wall fin applications

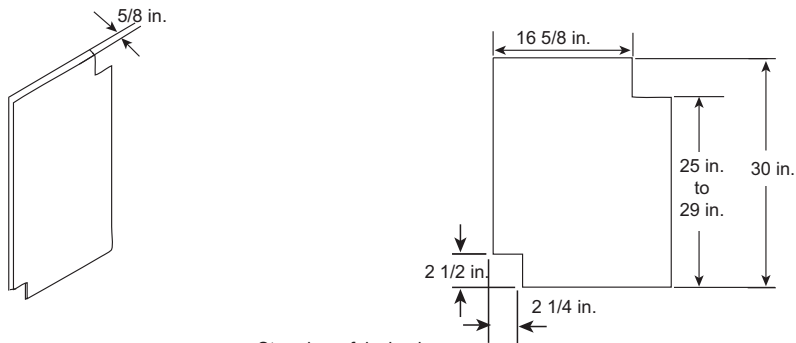

Step-down falseback end cover without cutouts

Figure 7. Wall boxes – V1 and V3

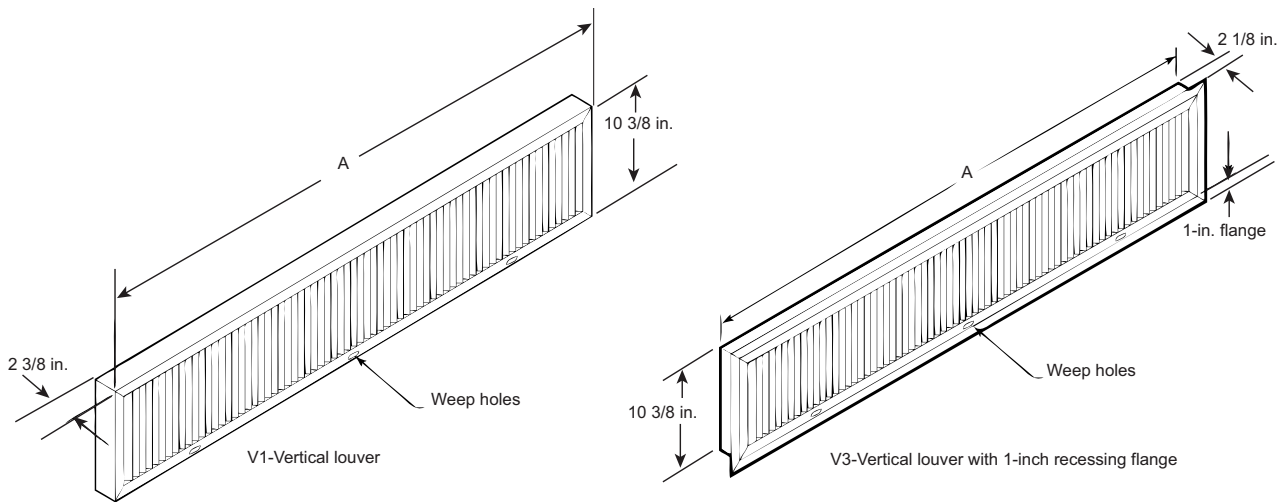

Table 7. V1 and V3 Wall box dimensions (inches)

| Unit size | A      | Free Area (ft <sup>2</sup> ) |
|-----------|--------|------------------------------|
| 075       | 42 1/8 | 1.39                         |
| 100       | 54 1/8 | 1.88                         |
| 125       | 66 1/8 | 2.37                         |

Table 7. V1 and V3 Wall box dimensions (inches) (continued)

| Unit size | A      | Free Area (ft <sup>2</sup> ) |
|-----------|--------|------------------------------|
| 150/200   | 78 1/8 | 2.87                         |

Note: Dimensions listed are above the actual (not nominal) dimensions. Vertical blades of V1 and V3 wall boxes are spaced 3/8 inch apart.

Figure 8. Wall boxes – V2 and V6

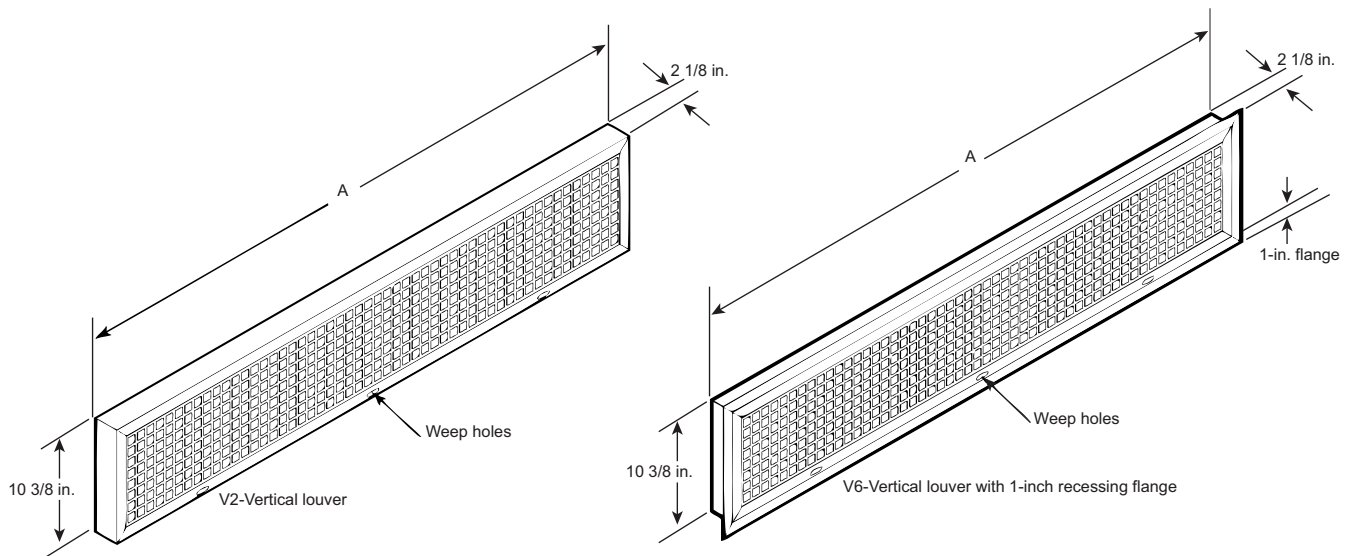

Table 8. V1 and V3 Wall box dimensions (inches)

| Unit size | A      | Free Area (ft <sup>2</sup> ) |
|-----------|--------|------------------------------|
| 075       | 42 1/8 | 1.04                         |
| 100       | 54 1/8 | 1.35                         |
| 125       | 66 1/8 | 1.68                         |

Table 8. V1 and V3 Wall box dimensions (inches) (continued)

| Unit size | A      | Free Area (ft <sup>2</sup> ) |
|-----------|--------|------------------------------|
| 150/200   | 78 1/8 | 1.99                         |

Note: Dimensions listed are above the actual (not nominal) dimensions. Vertical blades of V2 and V6 wall boxes are spaced 3/8 inch apart.

## Dimensions and Weights

**Figure 9. Crossover piping**

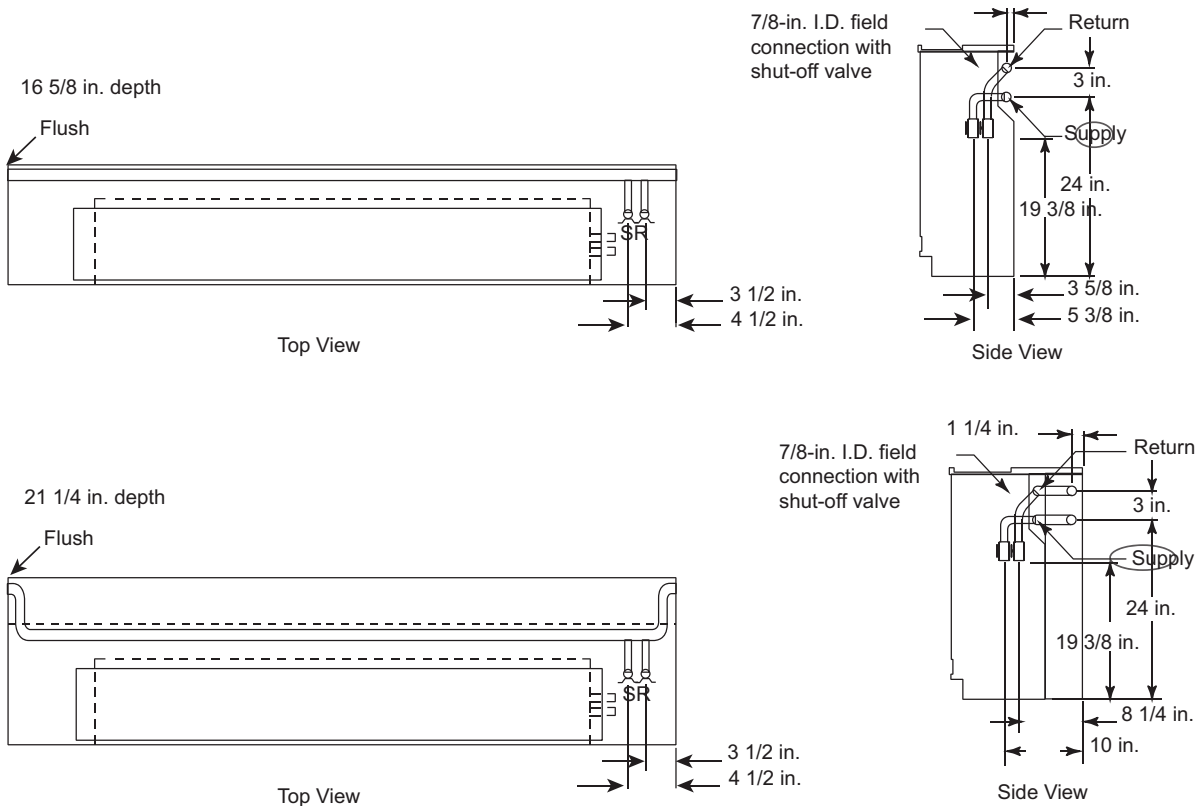

**Note:** 1-3/8 in. OD and 2-1/8 in. ID crossover piping.

1. Crossover piping is available for all 2- or 4-pipe coil selections. Trane provides the crossover for the hot water only. The crossover pipe is factory insulated with 3/8 in.-thick insulation.
2. Expansion compensation between the factory piping package and the crossover piping is achieved using a flex hose rated at 250 psi working pressure. Flex hose is only available with factory mounted piping packages.
3. Expansion compensation for the crossover piping must be handled external to the unit ventilator.
4. Crossover connections terminate in the same end pocket as the heating coil on all 2- and 4-pipe coils.



# Installation - Mechanical

## Installation Checklist

The following checklist is only an abbreviated guide to the detailed installation procedures given in this manual. Use this list to ensure all necessary procedures are complete. For more detailed information, refer to the appropriate sections in this manual.

### ⚠ WARNING

#### Hazardous Voltage w/Capacitors!

Failure to disconnect power and discharge capacitors before servicing could result in death or serious injury.

Disconnect all electric power, including remote disconnects and discharge all motor start/run capacitors before servicing. Follow proper lockout/tagout procedures to ensure the power cannot be inadvertently energized. Verify with a CAT III or IV voltmeter rated per NFPA 70E that all capacitors have discharged.

- Inspect the unit for shipping damage.
- Level installation location to support the unit weight adequately. Make all necessary wall or ceiling openings to allow adequate air flow and service clearances.
- Ensure the unit chassis is installed level.
  - Important:** *The unit must be installed level (zero tolerance) in both horizontal axis for proper operation. Do not use the coil or drain pan as the reference point because the coil may be pitched and the drain pan an inherent positive slope to provide proper drainage.*
- Verify that wall openings are properly cut per the unit submittals.
- Complete all piping connections correctly.
- Check field sweat connections for leaks and tighten the valve stem packing, and piping package unions if necessary.
- Install entering water temperature sensor on the supply water line, if applicable.
- Install condensate overflow switch option correctly on the auxiliary drain pan, if applicable.
- Ensure the low temperature detection device option is correctly installed.
- Complete all necessary duct connections.
- Complete all interconnection wiring for the wallmounted fan mode switch or zone sensor per the wiring schematic and guidelines established in [Step 17](#).
- Install the wall-mounted fan mode switch, or zone sensor module options properly.

For wireless zone sensors, be sure to set the address (see "[Address Setting](#)," p. 50).

- Make field mounted controller / fan speed switch connections to CSTI / FSS as indicated on unit schematic.
- Connect electrical supply power according to the NEC and unit wiring diagrams.
- Remove any miscellaneous debris, such as sheetrock dust, that may have infiltrated the unit during construction.
- Replace the air filter as required.

## Wall Box Installation

The following instructions are general recommendations for installing wall intake boxes. Consult the architectural plans for specific requirements.

Additional materials required to complete any specific installations (such as duct connections, metal mounting plates, or flanges) are not furnished by Trane.

For best results, all air intake boxes should be removable from outside of the building. Weep holes must be at the bottom to permit free drainage. A positive air and moisture seal should be provided around all edges.

### General Instructions

For Trane wall box, dimensions are actual, and may be used to define the wall opening.

Vertical louvers in the wall intake box provide extra strength for a high load bearing capacity. The lintel may be omitted on masonry wall installations.

Weep holes are provided in the outside face of the bottom channel in the wall box frame. Install all wall boxes to permit free drainage through the weep holes to the outside of the building.

All wall boxes are furnished with diamond pattern expanded aluminum bird screen.

**Note:** *V1 and V2 (vertical) wall models are all unflanged. H2, V3, and V6 are flanged.*

### Installation in Masonry Walls

A typical method of installing the wall box in a masonry wall opening is shown below.

Figure 10. Masonry wall installation

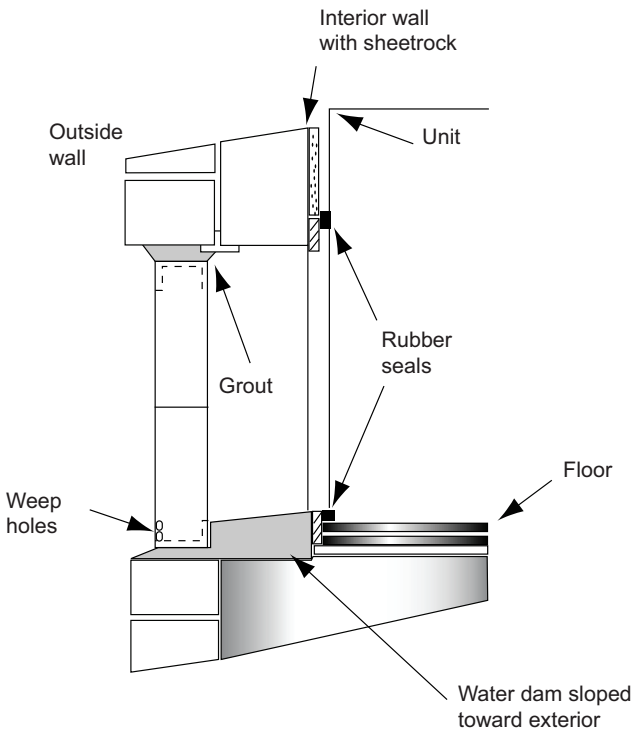

Grout the top and bottom of the wall box frame as noted. A sloped water dam located in the space between the unit and wall facilitates moisture drainage. Grouting at the ends of the intake box will complete the seal between the wall box frame and the masonry opening.

### Installation in Curtain Walls

In all cases, the wall intake box should be caulked to provide a tight, weatherproof seal (see Figure 11, p. 22).

**Note:** A minimum of 2-1/8 in. of clearance must be maintained between the exterior wall and back of the unit. Failure to provide this gap will not allow the wall box to fit properly.

Figure 11. Flanged wall box installation in 2-in. curtain wall

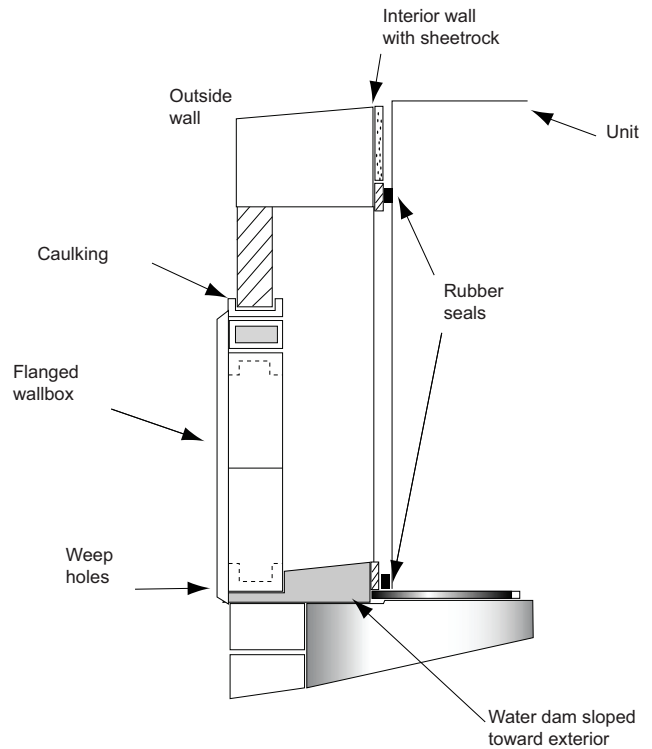

## Installing the Unit

Follow the procedures below to install the unit properly. Refer to for specific unit dimensions and mounting hole locations.

**Note:** All wall intake boxes should be installed prior to mounting the unit ventilator. Refer to the wall box installation section for instructions.

**⚠ WARNING**

**Electrical Short Hazard!**  
 Failure to follow instructions below could cause electrical shorts that could result in death or serious injury.  
 Prevent wiring from being pinched between unit and installation surface.

Figure 12. Mounting hole location

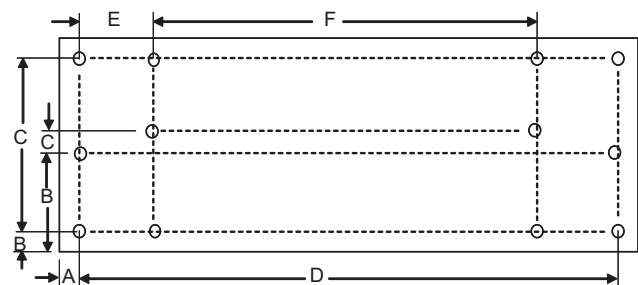

There are 1/2-inch mounting or anchoring holes located on the back of the unit on each end.

**Note:** All mounting fasteners are to be provided by the installer.

**Table 9. Mounting hole location (inches)**

| Unit size | Type                         | A    | B     | C     | D      | E     | F     |
|-----------|------------------------------|------|-------|-------|--------|-------|-------|
| 075       | Standard unit (no falseback) | 1.31 | 13.50 | 2.75  | 66.39  | 10.38 | 45.64 |
|           | Standard falseback           | 1.00 | 2.13  | 26.00 | 67.00  | 10.00 | 47.00 |
|           | 29 in. stepdown falseback    | 1.00 | 2.13  | 24.44 | 67.00  | 10.00 | 47.00 |
|           | 28 in. stepdown falseback    | 1.00 | 2.13  | 23.44 | 67.00  | 10.00 | 47.00 |
|           | 27 in. stepdown falseback    | 1.00 | 2.13  | 22.44 | 67.00  | 10.00 | 47.00 |
|           | 26 in. stepdown falseback    | 1.00 | 2.13  | 21.44 | 67.00  | 10.00 | 47.00 |
|           | 25 in. stepdown falseback    | 1.00 | 2.13  | 20.44 | 67.00  | 10.00 | 47.00 |
| 100       | Standard unit (no falseback) | 1.31 | 13.50 | 2.75  | 78.39  | 10.38 | 57.64 |
|           | Standard falseback           | 1.00 | 2.13  | 26.00 | 79.00  | 10.00 | 59.00 |
|           | 29 in. stepdown falseback    | 1.00 | 2.13  | 24.44 | 79.00  | 10.00 | 59.00 |
|           | 28 in. stepdown falseback    | 1.00 | 2.13  | 23.44 | 79.00  | 10.00 | 59.00 |
|           | 27 in. stepdown falseback    | 1.00 | 2.13  | 22.44 | 79.00  | 10.00 | 59.00 |
|           | 26 in. stepdown falseback    | 1.00 | 2.13  | 21.44 | 79.00  | 10.00 | 59.00 |
|           | 25 in. stepdown falseback    | 1.00 | 2.13  | 20.44 | 79.00  | 10.00 | 59.00 |
| 125       | Standard unit (no falseback) | 1.31 | 13.50 | 2.75  | 90.39  | 10.38 | 69.64 |
|           | Standard falseback           | 1.00 | 2.13  | 26.00 | 91.00  | 10.00 | 71.00 |
|           | 29 in. stepdown falseback    | 1.00 | 2.13  | 24.44 | 91.00  | 10.00 | 71.00 |
|           | 28 in. stepdown falseback    | 1.00 | 2.13  | 23.44 | 91.00  | 10.00 | 71.00 |
|           | 27 in. stepdown falseback    | 1.00 | 2.13  | 22.44 | 91.00  | 10.00 | 71.00 |
|           | 26 in. stepdown falseback    | 1.00 | 2.13  | 21.44 | 91.00  | 10.00 | 71.00 |
|           | 25 in. stepdown falseback    | 1.00 | 2.13  | 20.44 | 91.00  | 10.00 | 71.00 |
| 150       | Standard unit (no falseback) | 1.31 | 13.50 | 2.75  | 102.39 | 10.38 | 81.64 |
|           | Standard falseback           | 1.00 | 2.13  | 26.00 | 103.00 | 10.00 | 83.00 |
|           | 29 in. stepdown falseback    | 1.00 | 2.13  | 24.44 | 103.00 | 10.00 | 83.00 |
|           | 28 in. stepdown falseback    | 1.00 | 2.13  | 23.44 | 103.00 | 10.00 | 83.00 |
|           | 27 in. stepdown falseback    | 1.00 | 2.13  | 22.44 | 103.00 | 10.00 | 83.00 |
|           | 26 in. stepdown falseback    | 1.00 | 2.13  | 21.44 | 103.00 | 10.00 | 83.00 |
|           | 25 in. stepdown falseback    | 1.00 | 2.13  | 20.44 | 103.00 | 10.00 | 83.00 |

### **⚠ WARNING**

#### **Improper Unit Lift!**

Failure to properly lift unit in a LEVEL position could result in unit dropping and possibly crushing operator/technician which could result in death or serious injury, and equipment or property-only damage.

Test lift unit approximately 24 inches (61 cm) to verify proper center of gravity lift point. To avoid dropping of unit, reposition lifting point if unit is not level.

1. Set the unit into selected location and adjust leveling legs if necessary to ensure level fit.

**Note:** Care should be taken when handling the unit to ensure that the front return air grille does not bend.

2. Push the unit tightly against the wall to compress the seal on the back edge of the unit and intake opening. Anchor the unit by using the 1/2 in. mounting holes in both end pockets.

Units containing a falseback: The falseback unit ventilator contains mounting holes located on the falseback metal. Use these holes rather than the holes located in the unit's end pockets.

**Note:** Ensure the unit is level. Coils and drain pans inside the unit are pitched properly for draining before shipment.

3. Ensure the unit rests tightly against the wall. Check for proper seal and that air does not leak underneath the unit.

### Subbase (Option)

A subbase may be used to increase the unit height and aid in leveling the unit. The subbase is shipped separately for field installation. Slots and leveling screws are provided on the subbase.

1. Remove the leveling legs provided with the unit.

**Figure 13. Subbase with leveling legs**

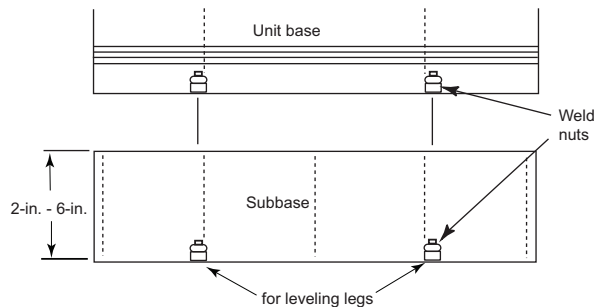

2. Set the unit on the subbase and fasten with four, 0.375-16 x 1 in. hex head cap screws and 3/8 in. lock washers.

**Note:** Hex screws and lock washers are provided by the factory. They are located in a baggy and are used to attach the base to the unit ventilator. Pre-drilled slots in the subbase flange will line up with the weld nuts in the bottom of the unit.

3. The bottom of the subbase has weld nuts in four slots. Place the leveling legs in those slots and level the unit.

### NOTICE

#### Equipment Damage!

Failure to follow instructions below could result in equipment damage.

Do not operate units for any length of time without properly installing all panels, filters, and grilles.

### End Panels

When ordered as an option, end covers ship attached to the vertical unit ventilator. The following section is for installing end covers purchased as an add-on.

It is recommended end panels be installed on the unit ventilator after all piping, wiring and accessory installation is completed. To install the end panel:

1. Insert the four factory-provided metal studs into the four pre-mounted nuts on the inside of the panel.
2. Align each stud with the four pre-drilled holes on the side of the unit.
3. Secure the panel to the unit by fastening with the four factory provided nuts.
4. Do not overtighten screws.



# Coil Piping and Connections

## Coil Piping and Connections

The coil headers and drain connections are made within the unit chassis to allow a tight seal and help prevent air leakage around the coil. The connection sizes vary dependent upon type of coil combination specified.

**Table 10. Operating limits**

| Description              | Minimum | Maximum |
|--------------------------|---------|---------|
| Operating Pressure (psi) | 10      | 400     |
| Fluid Temperature (°F)   | 0       | 200     |

**Table 11. Coil data for field piping**

| Coil type                      | Connection location           | Field connection size               |
|--------------------------------|-------------------------------|-------------------------------------|
| 4-pipe chilled water/hot water | Left or right (opposite ends) | 7/8 in. OD/5/8 in. OD               |
| 2-pipe changeover coil         | Left or right                 | 7/8 in. OD                          |
| Hot water only                 | Left or right                 | 7/8 in. OD                          |
| Steam                          | Left or right                 | 1 in. FPT                           |
| Chilled water/electric heat    | Left cooling                  | 7/8 in. OD                          |
| Chilled water/steam            | Left or right                 | 7/8 in. OD/1 in. FPT                |
| DX                             | Left                          | 7/8 in. suction, 3/8 in.            |
| DX/hot water                   | Left cooling/ right heating   | 7/8 in. suction, 3/8 in./5/8 in. OD |
| DX/steam                       | Left cooling/ right heating   | 7/8 in. suction, 3/8 in./1 in. FPT  |
| DX/electric heat               | Left cooling/ right heating   | 7/8 in. suction, 3/8 in./n/a        |

A 7/8-inch OD condensate drain connection is provided on the chilled-water supply end of the unit.

1. Attach a flexible condensate drain hose over the drain pan connection and secure with a hose clamp.  
The drain pan on the vertical is vacuum-molded with a drain connection and P-trap on the cooling coil, connection side.

**Note:** Condensate removal to the main system should be made through the bottom of the unit ventilator. If other location for condensate removal is desired, a specific field cut-out for the connection should be made in the back of the unit ventilator. To help avoid cold air infiltration, the field cut-out should only be large enough to allow for the condensate hose to exit the unit. To minimize risk of cold air infiltration, seal any gap around condensate piping field or factory cutouts.

- To field reverse the slope of a vertical unit drain pan:
2. Slide out fan deck (disconnecting the condensate line and fan plug will release fan deck for sliding).
  3. Remove pipe clamp that hold the p-trap to the drain pan.
  4. Remove clips that hold the drain pan in-place.
  5. Lift and rotate the drain pan.
  6. Reconnect p-trap to the drain pan and replace clips to secure the pan to the fan deck.
  7. After the condensate drain piping has been completed, check water flow to ensure the system properly carries and away all condensate accumulation.

**Note:** A p-trap is factory-supplied for vertical unit ventilators that include cooling elements.

## Piping Packages

Before installation of piping package, the shipping bracket holding the piping in place, must be removed.

Control valves are mounted in all factory piping packages. All piping packages are factory installed and come in a variety of options:

- **Basic:** Union and shut-off ball valve on the supply line. Union, control valve and shut-off ball valve on the return line.
- **Basic with Manual Circuit Setter:** Union, shut-off ball valve on the supply line. Union, control valve and manual circuit setter on the return line.
- **Deluxe with Manual Circuit Setter:** Union, strainer, P/T port, and shut-off ball valve on the supply line. Union, control valve and manual circuit setter on the return line.
- **Deluxe with Auto Flow:** Union, strainer, P/T port, and shut-off ball valve on the supply line. Union, control valve, auto flow valve, P/T port and shut-off ball valve on the return line.

# Coil Piping and Connections

**Figure 14. Basic piping package**

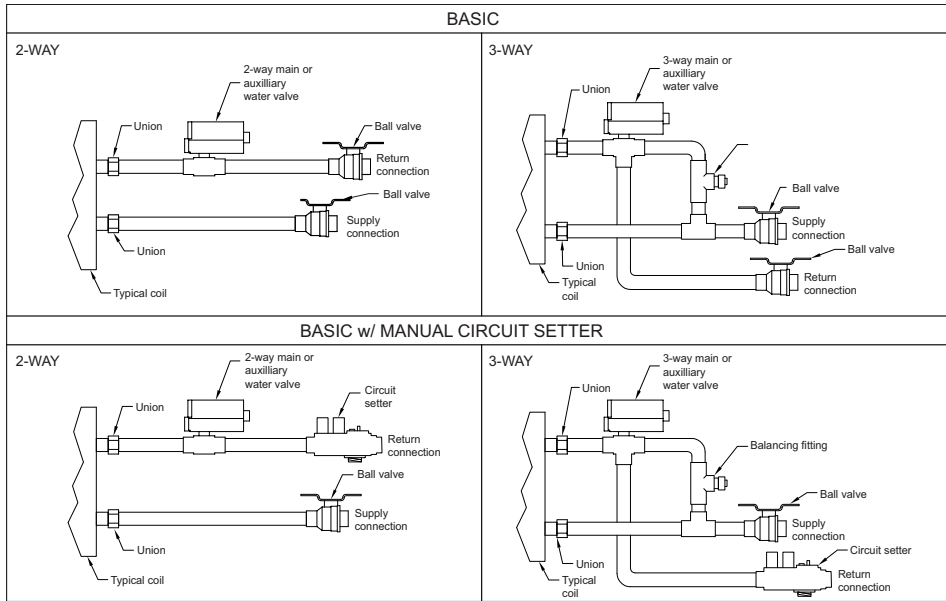

**Figure 15. Deluxe piping package**

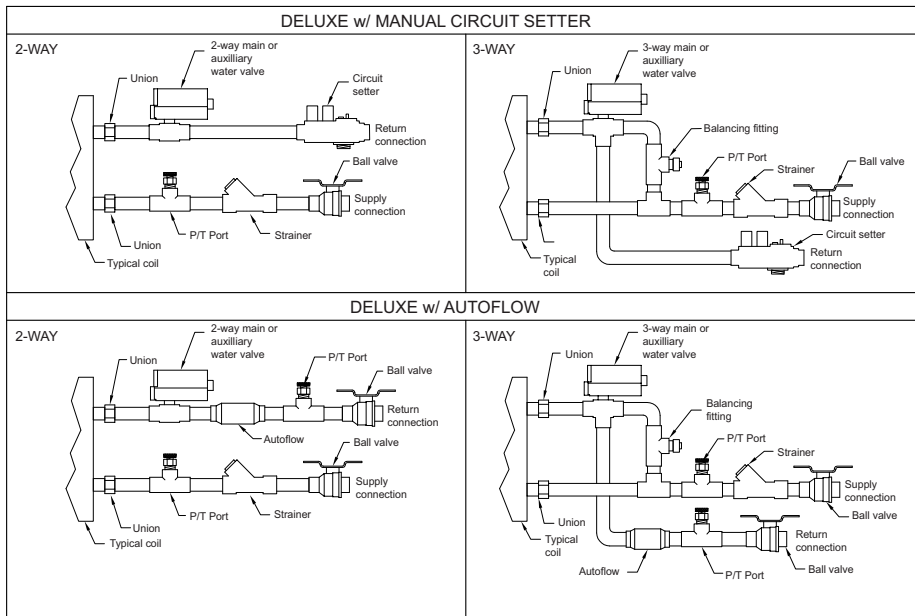

**Figure 16. Supply and return connection**

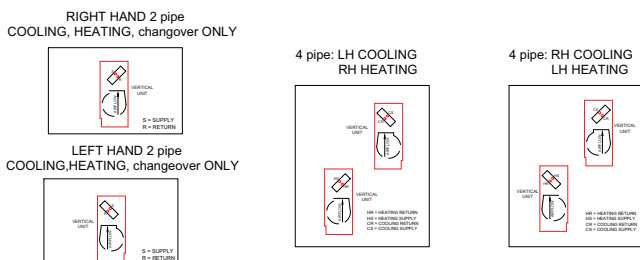

All union connections should be tightened in the field. Units are shipped with union connections hand tightened only in the factory.

Proper installation of piping is necessary to provide efficient coil operation and to prevent damage during operation.

Piping connection knockouts are shown in "Dimensions and Weights," p. 13. Field connection types and sizes for unit coils are listed in Table 11, p. 25. These sizes are provided for field piping connection.

**Notes:**

- All connections made in the field should be sweat connections.
- Piping packages are not shipped insulated. Any insulation should be provided in the field by the installing contractor.

The auxiliary drain pan (optional) is the main condensate connection to the unit when specified. The chilled water or DX coil drain pan will empty into the auxiliary drain pan if a factory-installed, auxiliary pan is ordered. All field-piping condensate connections should be made at the auxiliary drain pan.

**Figure 17. Manual circuit setter valve, differential pressure vs. flow 1/2 inch**

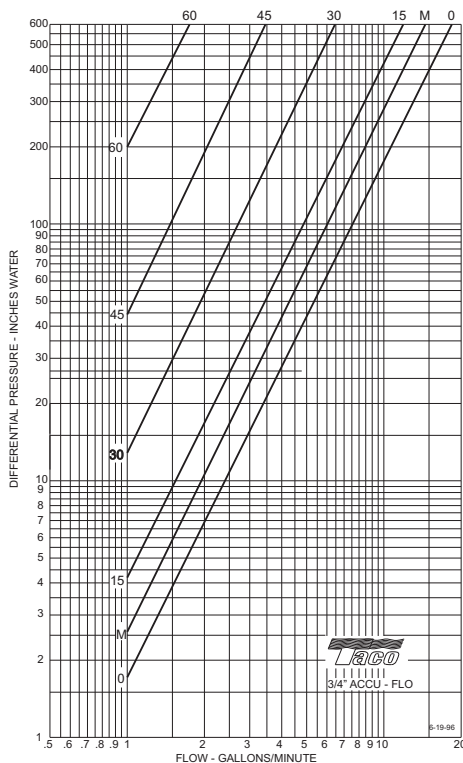

**Note:** Instructions for using this chart appear on the preceding page. For the manual circuit setter provided the unit, use the 'M' curve.

**Figure 18. Manual circuit setter valve, differential pressure vs. flow 1/2 inch**

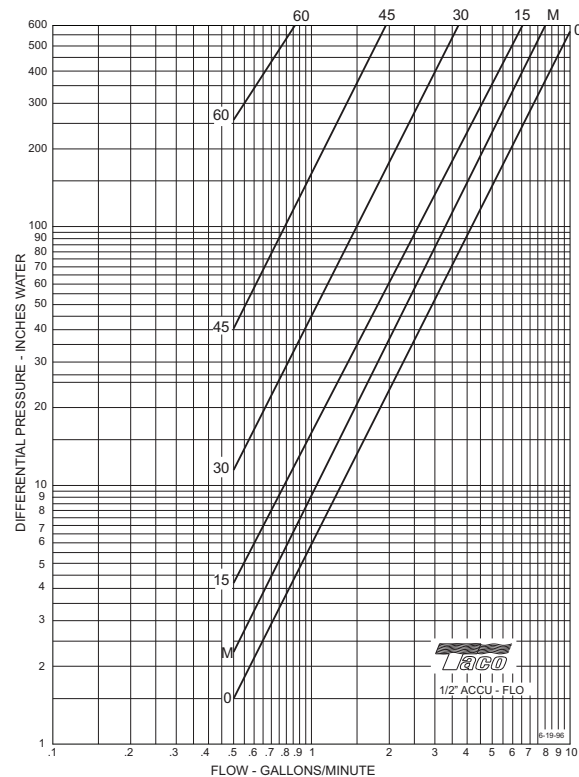

**Note:** Instructions for using this chart appear on the preceding page. For the manual circuit setter provided the unit, use the 'M' curve.

## Valve and Actuator Operation

- NO and NC actuators are different parts. The 7.4 Cv 3-way actuator is spring return. All the other 2-position actuators are capacitor discharge return.
- Valves can be interchanged among the different actuator types.
- All actuators are clockwise to close and counterclockwise to open with wire harness facing you and looking at the top of the actuator.

## Valve Stroke Time

**Table 12. Valve stroke time**

| Valve Selection                                     | End Stop Position | Stroke Time (seconds) |
|---|-------------------|-----------------------|
| 1.4 Cv, 1/2 in. 2-Way Modulating Valve              | No end stop       | 75                    |
| 2.4 Cv, 1/2 in. 2-Way Isolation Valve               | 5                 | 55                    |
| 3.4 Cv, 1/2 in. 2-Way Modulating Valve              | 6                 | 62                    |
| 4.8 Cv, 1/2 in. 2-Way Modulating & 2 Position Valve | N                 | 68                    |

**Table 12. Valve stroke time (continued)**

| Valve Selection                                     | End Stop Position | Stroke Time (seconds) |
|---|-------------------|-----------------------|
| 5.9 Cv, 1/2 in. 2-Way Modulating Valve              | No end stop       | 75                    |
| 2.3 Cv, 3/4 in. 2-Way Modulating & 2 Position Valve | 4                 | 49                    |
| 3.3 Cv, 3/4 in. 2-Way Modulating Valve              | 5                 | 55                    |
| 4.6 Cv, 3/4 in. 2-Way Modulating & 2 Position Valve | 6                 | 62                    |
| 6.6 Cv, 3/4 in. 2-Way Modulating Valve              | N                 | 68                    |
| 2.7 Cv, 1/2 in. 3-Way Modulating & 2 Position Valve | No end stop       | 75                    |
| 4.6 Cv, 3/4 in. 3-Way Modulating Valve              | No end stop       | 75                    |
| 7.4 Cv, 3/4 in. 3-Way Modulating & 2 Position Valve | N/A               | 90                    |

## Balancing Manual Circuit Setter Valve

The manual circuit setter valve is an optional end valve supplied on the return pipe of the factory piping package. The valve allows the operator to regulate water flow through the hydronic coil, balance the water flow through the unit with other units in the piping system, and serves as a shut-off or end valve. See the figure below.

**Figure 19. Manual circuit setter valve**



Perform the following procedure to set maximum water flow through the coil:

1. Establish water flow through the coil. Perform an open override of the valve if the control valve is closed to the coil, either manually or by Tracer®.

If the piping package has two-position, normally closed valves: Drive open the valve using a 24 V signal.

If the piping package has two-position, normally open valves: Manually drive open the valve by removing power to the valve.

If the piping package has modulating valves: To manually drive the valve open, lift off the actuator and turn the valve stem. Actuator can be used to turn the valve stem.

2. For presetting, use the appropriate valve curve shown in [Figure 17, p. 27](#) and [Figure 18, p. 27](#) to determine

which setting is necessary to achieve the appropriate pressure drop.

3. Carefully remove the Schrader pressure port connection caps on the manual circuit setter, since they will be at the same temperature as the pipeline.
4. Bleed all air from the hoses and meter before reading the pressure drop. Refer to the gauge operating instructions.
5. Adjust the circuit setter valve by turning the valve stem until the appropriate pressure drop is achieved.
6. After achieving the proper setting, slightly loosen the two socket head cap screws and rotate the memory stop around until it touches the back side of the indicator. Then tighten the screws to securely set the open memory position. The memory stop indicates the last set open position.
7. If using a three-way valve: close the control valve to the coil, with the differential pressure meter still connected. This will divert flow to the bypass side of a three-way valve.

Adjust the fitting to obtain the same pressure drop across the circuit setter valve as in step two when the control valve was open to the coil.

## Split System Piping

The following refrigerant piping and interconnecting wiring instructions apply to unit ventilators with direct expansion type cooling coils used in conjunction with air-cooled condensing units. Reference must also be made to the condensing unit installation and wiring manuals which are shipped with the condensing unit.

**Note:** The UL listing mark applied to a unit ventilator does not apply to any associated refrigerant condensing unit.

## Refrigerant Piping

### ⚠ WARNING

#### Explosion Hazard and Deadly Gases!

Failure to follow all proper safe refrigerant handling practices could result in death or serious injury. Never solder, braze or weld on refrigerant lines or any unit components that are above atmospheric pressure or where refrigerant may be present. Always remove refrigerant by following the guidelines established by the EPA Federal Clean Air Act or other state or local codes as appropriate. After refrigerant removal, use dry nitrogen to bring system back to atmospheric pressure before opening system for repairs. Mixtures of refrigerants and air under pressure may become combustible in the presence of an ignition source leading to an explosion. Excessive heat from soldering, brazing or welding with refrigerant vapors present can form highly toxic gases and extremely corrosive acids.

Unit ventilators with direct expansion cooling contain a nitrogen holding charge in the evaporator coils. Connections are pinched-off at the factory.

To connect the condensing unit lines, cut off the stubouts and swage. The condensing unit lines can then be brought into the swage and brazed. Trane recommends the use of nitrogen purge when brazing refrigerant lines to prevent formation of oxides in the lines.

Install the refrigerant suction and liquid lines as described in the condensing unit installation instructions. The TXV is factory installed on the unit ventilator. Piping should be run straight out through the back of the unit. Access piping knockouts are located in the rear panels of the unit, as shown "Dimensions and Weights," p. 13.

Recommended refrigerant line connections for various unit combinations are given in Table 11, p. 25. Typical Superheat Charging Charts are shown in the Trane Service Facts found in the condensing unit section manual. Refrigerant charge weights can also be determined with your local Trane sales engineer using a valid Trane Selection Program.

### Steam Piping

When air, water or another product is heated, the temperature or heat transfer rate can be regulated by a modulating steam pressure control valve. Since pressure and temperature do not vary at the same rate as load, the steam trap capacity, which is determined by the pressure differential between the trap inlet and outlet, may be adequate at full load, but not some lesser load.

There are detailed methods for determining condensate load under various operating conditions. However, in most cases this is not necessary if the coils are piped as shown in Figure 20, p. 29. Follow the procedure documented in the ASHRAE Systems Handbook, Steam Systems.

**Figure 20. Steam piping**

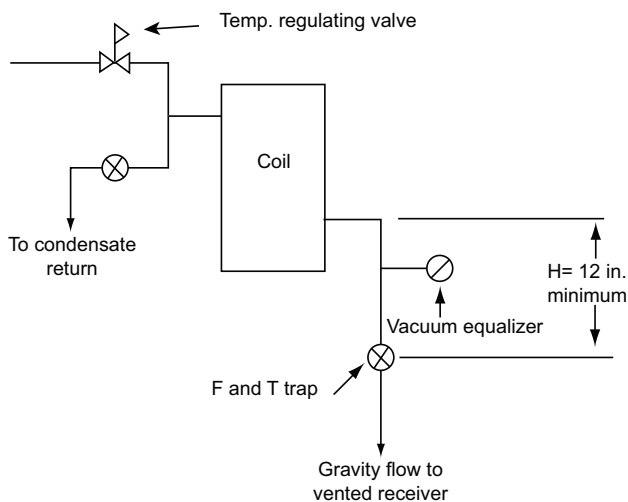

### Modulating Steam Valves

An optional 2-way modulating steam valve can be selected with steam coils. The valve is field installed. When plumbing the valve, the AB port must be connected to the coil.

**Figure 21. Belimo steam schematic**

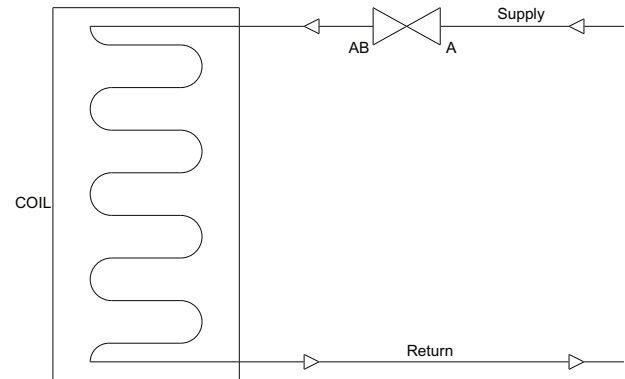

**Note:** The actuator must be mounted between 0 and 45 degrees from horizontal. Do not install with actuator below pipe.

**Figure 22. Steam valve orientation**

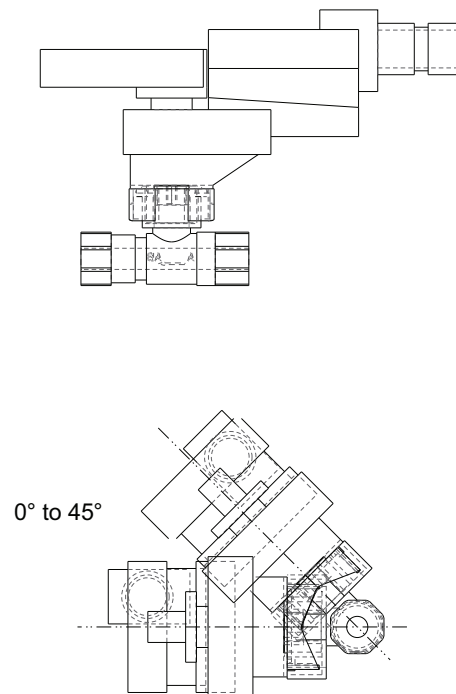

**Note:** The actuator must be removed when soldering near the valve. High heat may cause damage to the actuator's plastic body/mechanisms. The actuator can be removed from the valve by loosening the bolt going through the top of the actuator. When reinstalling the actuator, do not over tighten. Tighten bolt to 13.5 in-lb.

**Figure 23. Exploded valve assembly**

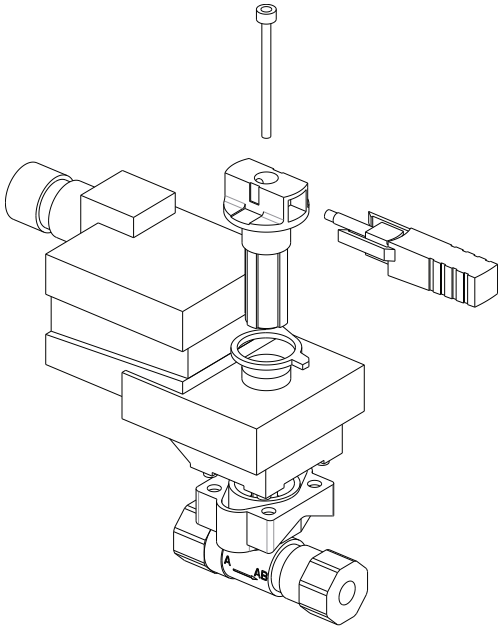

**Figure 24. Wiring for modulating steam valve actuator**

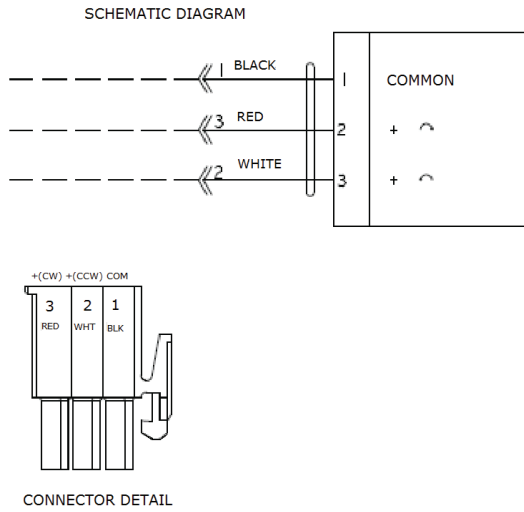



# A2L Information and Installation Requirements

## Installation/Code Compliance Requirements

Building level controls may need to be upgraded/modified to demand leak mitigation actions as described in “Leak Detection System (Refrigerant charge greater than 3.91 lb of R-454B or 4.04 lb of R-32 per circuit),” p. 37. Those actions include, but are not limited to, fully opening damper and VAV boxes (if present), and disabling electric heat in VAV boxes (if present).

Verify the equipment refrigerant charge is in accordance with the room area limitation as described in Minimum Room Area Limits section.

Ensure that there are labels on the equipment stating it contains a flammable refrigerant.

## A2L Work Procedures

### ⚠ WARNING

#### Risk of Fire — Flammable Refrigerant!

Failure to follow instructions below could result in death or serious injury, and equipment damage.

- To be repaired only by trained service personnel.
- Do not puncture refrigerant tubing.
- Dispose of properly in accordance with federal or local regulations.
- The equipment shall be stored in a room without continuously operating ignition sources.

### ⚠ WARNING

#### Refrigerant under High Pressure!

Failure to follow instructions below could result in an explosion which could result in death or serious injury or equipment damage.

System contains refrigerant under high pressure. Recover refrigerant to relieve pressure before opening the system. See unit nameplate for refrigerant type. Do not use non-approved refrigerants, refrigerant substitutes, or refrigerant additives.

### ⚠ WARNING

#### Hazardous Voltage!

Failure to disconnect power before servicing could result in death or serious injury.

Disconnect all electric power, including remote disconnects before servicing. Follow proper lockout/tagout procedures to ensure the power can not be inadvertently energized. Verify that no power is present with a voltmeter.

The units described in this manual use R-454B or R-32 refrigerant. Use ONLY R-454B or R-32 rated service equipment or components with these units. For specific handling concerns with R-454B or R-32 refrigerant, contact your local Trane representative.

Installation, repair, removal, or disposal should be performed by trained service personnel.

At all times, Trane’s maintenance and service guidelines shall be followed. If in doubt, contact Trane technical support for assistance.

## Service

Prior to initiating work on equipment, check the area with an appropriate refrigerant detector. Ensure the service personnel are properly trained regarding work in potentially toxic or flammable atmospheres. Ensure that the leak detection equipment being used is suitable for use with all applicable refrigerants, i.e. non-sparking, adequately sealed, or intrinsically safe. Be aware that the refrigerant does not contain an odor.

If any hot work is to be conducted on the refrigerating equipment or any associated parts, appropriate fire extinguishing equipment shall be available on hand. A dry powder or CO<sub>2</sub> fire extinguisher should be located adjacent to the charging area.

At all times, Trane’s maintenance and service guidelines shall be followed. If in doubt, contact Trane technical support for assistance.

All maintenance staff and others working in the local area shall be instructed on the nature of the work being carried out. Work in confined spaces shall be avoided.

## Ignition Source Mitigation

Do not use any sources of ignition when working on the refrigeration system.

Keep all ignition sources, including cigarette smoking, away from the site of installation, repair, removal or disposal, during which refrigerant can potentially be released to the surrounding space.

Survey the area around the equipment before initiating work to ensure no flammable hazards or ignition risks are present.

“No Smoking” signs shall be displayed.



## A2L Information and Installation Requirements

Do not use devices that can be a source of ignition to accelerate defrosting of components. Use only defrost and cleaning procedures recommended by Trane. Do not pierce or burn.

### Ventilation

Ensure that the area is in the open or that it is adequately ventilated before breaking into the system or conducting any hot work. A degree of ventilation shall continue during the period that the work is carried out. The ventilation should safely disperse any released refrigerant and preferably expel it externally into the atmosphere. If present, check that the ventilation system, including outlets, are operating adequately and are not obstructed.

### Refrigerating Equipment

Refrigerant piping or components should not be installed in locations where substances which may corrode them are present.

Check that equipment hazard markings are visible and legible. Replace them if they are not.

For equipment using secondary fluids, like water or glycol, check that refrigerant is not present in the secondary fluid loop before conducting any hot work.

### Electrical Devices

Do not apply power to the circuit if a fault exists which compromises safety. If the fault cannot be corrected immediately, but it is necessary to continue operation, an adequate temporary solution shall be used. This shall be reported to the owner of the equipment, so all parties are advised.

Initial safety checks shall include:

- Cabling is not subject to wear, corrosion, excessive pressure, vibration, sharp edges, or any other adverse environmental effects. Account for the effects of aging or continual vibration from sources such as compressors or fans.
- Capacitors are discharged. This shall be done in a safe manner to avoid possibility of sparking.
- No live electrical components and wiring are exposed while charging, recovering, or purging the system.
- Verify continuity of earth bonding.
- Replace electrical components with Trane replacement parts, or those meeting the same ratings and qualified for flame arrest protection, UL LZGH2 category.

### Leak Detection

Never use an open flame to detect leaks. A halide torch should not be used. Use only approved leak detection methods per this instruction manual.

The following leak detection methods are deemed acceptable for all refrigerant systems.

Electronic leak detectors may be used to detect refrigerant leaks but, in the case of flammable refrigerants, the sensitivity may not be adequate, or may need re-

calibration. (Detection equipment shall be calibrated in a refrigerant-free area.) Verify the detector is not a potential source of ignition and is suitable for the refrigerant used. Leak detection equipment shall be set at a percentage of the LFL gas (25% maximum) is confirmed.

Leak detection fluids are also suitable for use with most refrigerants but the use of detergents containing chlorine shall be avoided as the chlorine may react with the refrigerant and corrode the copper pipe-work.

Examples of leak detection fluids are:

- Bubble method
- Fluorescent method agents

If a leak is suspected, all naked flames shall be removed/ extinguished.

If a refrigerant leak is found which requires brazing, all refrigerant shall be recovered from the system, or isolated (by means of shut-off valves) in a part of the system remote from the leak.

### Refrigerant Removal and Evacuation

Ensure that the correct number of cylinders for holding the total system charge is available. All cylinders to be used are designated for the recovered refrigerant and labeled for that refrigerant (special cylinders for the recovery of refrigerant, for example). Cylinders shall be complete with pressure-relief valve and associated shut-off valves in good working order. Empty recovery cylinders are evacuated and, if possible, cooled before recovery occurs.

When breaking into the refrigerant circuit to make repairs – or for any other purpose – conventional procedures shall be used. However, for flammable refrigerants it is important that best practice be followed, since flammability is a consideration.

The following procedure shall be adhered to:

1. Safely remove refrigerant following local and national regulations.
2. Evacuate.
3. Purge the circuit with inert gas.
4. Evacuate (optional for A2L).
5. Continuously flush or purge with inert gas when using flame to open circuit.
6. Open the circuit.

Prior to refrigerant removal, open all appropriate valves, including solenoid and electronic expansion valves (EXVs). Use control settings, where available. When not available, manually open all electronically controlled valves using acceptable service procedures.

The recovery equipment shall be in good working order with instructions available. Equipment shall be suitable for the recovery of the flammable refrigerant. For specific handling concerns, contact the manufacturer. Ensure all hose connections are checked for tightness to avoid refrigerant leaks.

In addition, a set of calibrated weighing scales shall be available and in good working order.

The refrigerant shall be recovered into the correct recovery cylinders if venting is not allowed by local and national codes. Do not mix refrigerants in recovery unit and especially not in cylinders.

Refrigerant recovery unit should be purged with an inert gas after each use or before using with a different refrigerant Class – for example, A2L to A1.

If compressors or compressor oils are to be removed, ensure that they have been evacuated to an acceptable level to make certain that flammable refrigerant does not remain within the lubricant. The compressor body shall not be heated by an open flame or other ignition sources to accelerate this process. When oil is drained from a system, it shall be carried out safely.

The system shall be purged with oxygen-free nitrogen to render the appliance safe for flammable refrigerants. This process might need to be repeated several times. Compressed air or oxygen shall not be used for purging refrigerant systems.

The system shall be vented down to atmospheric pressure to enable work to take place.

The outlet for the vacuum pump shall not be close to any potential ignition sources, and ventilation shall be available.

## Refrigerant Charging

In addition to conventional charging procedures, the following requirements shall be followed.

- Ensure that contamination of different refrigerants does not occur when using charging equipment.
- Hoses or lines shall be as short as possible to minimize the amount of refrigerant contained in them.
- Cylinders shall be kept in an appropriate position according to the instructions.
- Ensure that the refrigerating system is earthed prior to charging the system with refrigerant.
- Label the system when charging is complete (if not already).
- Extreme care shall be taken not to overfill the refrigerating system.

Prior to recharging the system, it shall be pressure-tested with the appropriate purging gas. The system shall be leak-tested on completion of charging but prior to commissioning. A follow up leak test shall be carried out prior to leaving the site.

Prior to refrigerant charging, open all appropriate valves, including solenoid and electronic expansion valves (EXVs). Use control settings, where available. When not available, manually open all electronically controlled valves using acceptable service procedures.

Verify the equipment refrigerant charge is in accordance with the room area limitation as described in Minimum Room Area Limits section.

## Decommissioning

Before carrying out the decommissioning procedure, it is essential that the trained service personnel is completely familiar with the equipment and all its details. It is recommended good practice that all refrigerants are recovered safely. Prior to the task being carried out, an oil and refrigerant sample shall be taken in case analysis is required prior to re-use of recovered refrigerant. It is essential that electrical power is available before the task is commenced.

1. Become familiar with the equipment and its operation.
2. Isolate system electrically.
3. Before attempting the procedure, ensure that:
  - a. Mechanical handling equipment is available, if required, for handling refrigerant cylinders.
  - b. All personal protective equipment is available and being used correctly.
  - c. The recovery process is supervised at all times by a competent person.
  - d. Recovery equipment and cylinders conform to the appropriate standards.
4. Pump down refrigerant system, if possible.
5. If a vacuum is not possible, make a manifold so that refrigerant can be removed from various parts of the system.
6. Make sure that cylinder is situated on the scales before recovery takes place.
7. Start the recovery machine and operate in accordance with instructions.
8. Do not overfill cylinders (no more than 80% volume liquid charge).
9. Do not exceed the maximum working pressure of the cylinder, even temporarily.
10. When the cylinders have been filled correctly and the process completed, make sure that the cylinders and the equipment are removed from site promptly and all isolation valves on the equipment are closed off.
11. Recovered refrigerant shall not be charged into another refrigerating system unless it has been cleaned and checked.
12. When equipment has been decommissioned, attach a signed and dated label stating it has been decommissioned and emptied of refrigerant.
13. Ensure that there are labels on the equipment stating it contains flammable refrigerant.

## A2L Application Considerations

This product is listed to UL standard 60335-2-40, Household and Similar Electrical Appliances – Safety – Part 2-40: Particular Requirements for Electrical Heat Pumps, Air-Conditioners and Dehumidifiers, which defines safe design and use strategies for equipment using A2L



## A2L Information and Installation Requirements

refrigerants. This standard limits the refrigerant concentration in a space in the event of a refrigerant leak. To meet the requirements, the UL standard defines minimum room area, refrigerant charge limit, minimum circulation airflow and/or ventilation airflow requirements, and limits the use of ignition sources in spaces. The standard requires a unit refrigerant leak detection system.

For equipment with less than or equal to 3.91 lb of R-454B or 4.04 lb of R-32 refrigerant charge per circuit, this UL standard does not prescribe a room area limit and does not require a refrigerant leak detection system or any circulation airflow or ventilation airflow mitigation strategies. However, ignition sources in ductwork must be evaluated.

Depending on the application, a specific requirement of ANSI/ASHRAE Standard 15, Safety Standard for Refrigeration Systems, could be more stringent than UL 60335-2-40 requirements. See *Refrigeration Systems and Machinery Rooms Application Considerations for Compliance with ASHRAE® Standard 15-2022 Application Engineering Manual* (APP-APM001\*-EN) for more information.

### Ignition Sources in Ductwork

Do not install open flames in the ductwork. Hot surfaces exceeding 700°C (1290°F) should not be installed in the ductwork unless the average airflow velocity is not less than 1.0 m/s (200 ft/min) across the heater and proof of airflow is verified before system is energized.

Electric heaters can exceed the surface temperature limit if airflow distribution is poor, or insufficient airflow is provided over the heater.

Surface temperatures of most gas heaters do not exceed the surface temperature limits due to ANSI construction requirements.

### Ignition Sources in Unit

This unit does not contain any ignition sources. All potential ignition sources, (including factory or field installed accessory electric heaters, gas heaters, relays, and contactors) were evaluated during product UL listing.

### Minimum Room Area Limits (Refrigerant charge greater than 3.91 lb of R-454B per circuit)

Equipment with R-454B refrigerant charge amounts greater than 3.91 lb per circuit may require additional circulation or ventilation airflow mitigation strategies. In this case, there are two minimum room area ( $A_{min}$ ) thresholds.

- The first threshold defines when equipment serving a single room is required to provide circulation airflow, either continuous or activated by a leak detection

system A ducted system requires circulation airflow unless the smallest room it serves is larger than the adjusted  $A_{min}$  threshold. This product contains a leak detection system if a circuit charge is greater than 3.91 lbs. As a result, no further leak detection system evaluation is needed.

- The second threshold defines when additional ventilation airflow is required. If the room area, A or TA, is below the adjusted  $A_{min}$  or  $TA_{min}$  threshold, additional ventilation is required to remove refrigerant in the event of a leak. Refer to UL 60335-2-40 Clause GG.8 and ANSI/ASHRAE Standard 15 Section 7 for natural and mechanical ventilation requirements. See equipment nameplate and table below for minimum room area.

Split systems minimum room area requirements need to be determined after final field charging. Use the following figures and the largest final circuit charge to determine the systems  $A_{min}$  value. Record the final charge value on the label provided on the condensing unit.

### Minimum Room Area Limits (Refrigerant charge greater than 4.04 lb of R-32 per circuit)

Equipment with refrigerant charge amounts greater than 4.04 lb of R-32 per circuit may require additional circulation or ventilation airflow mitigation strategies. In this case, there are two minimum room area ( $A_{min}$ ) thresholds.

- The first threshold defines when equipment serving a single room is required to provide circulation airflow, either continuous or activated by a leak detection system A ducted system requires circulation airflow unless the smallest room it serves is larger than the adjusted  $A_{min}$  threshold. This product contains a leak detection system if a circuit charge is greater than 4.04 lb of R-32. As a result, no further leak detection system evaluation is needed.
- The second threshold defines when additional ventilation airflow is required. If the room area, A or TA, is below the adjusted  $A_{min}$  or  $TA_{min}$  threshold, additional ventilation is required to remove refrigerant in the event of a leak. Refer to UL 60335-2-40 Clause GG.8 and ANSI/ASHRAE Standard 15 Section 7 for natural and mechanical ventilation requirements. See equipment nameplate and table below for minimum room area.

Split systems minimum room area requirements need to be determined after final field charging. Use the following figures and the largest final circuit charge to determine the systems  $A_{min}$  value. Record the final charge value on the label provided on the condensing unit.

Figure 25. Charge vs min room area (IP) – R-454B refrigerant

Charge vs Min Room Area (IP)

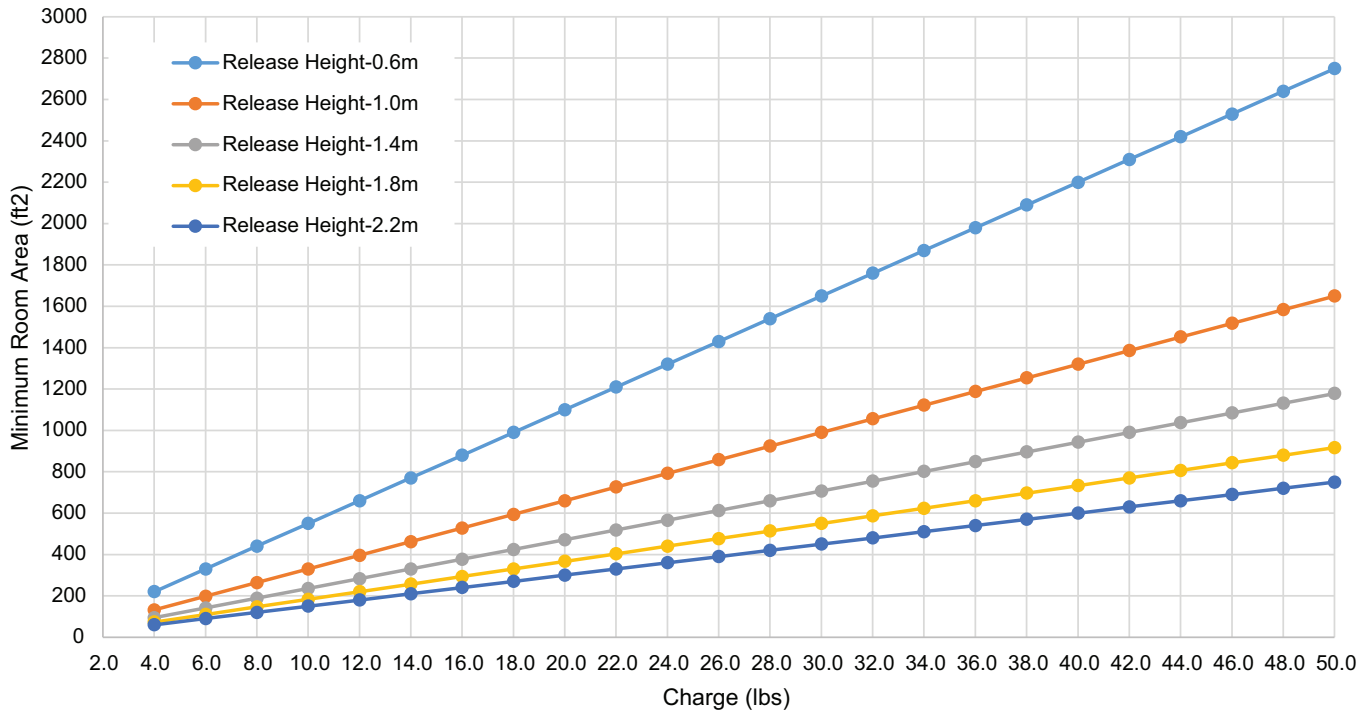
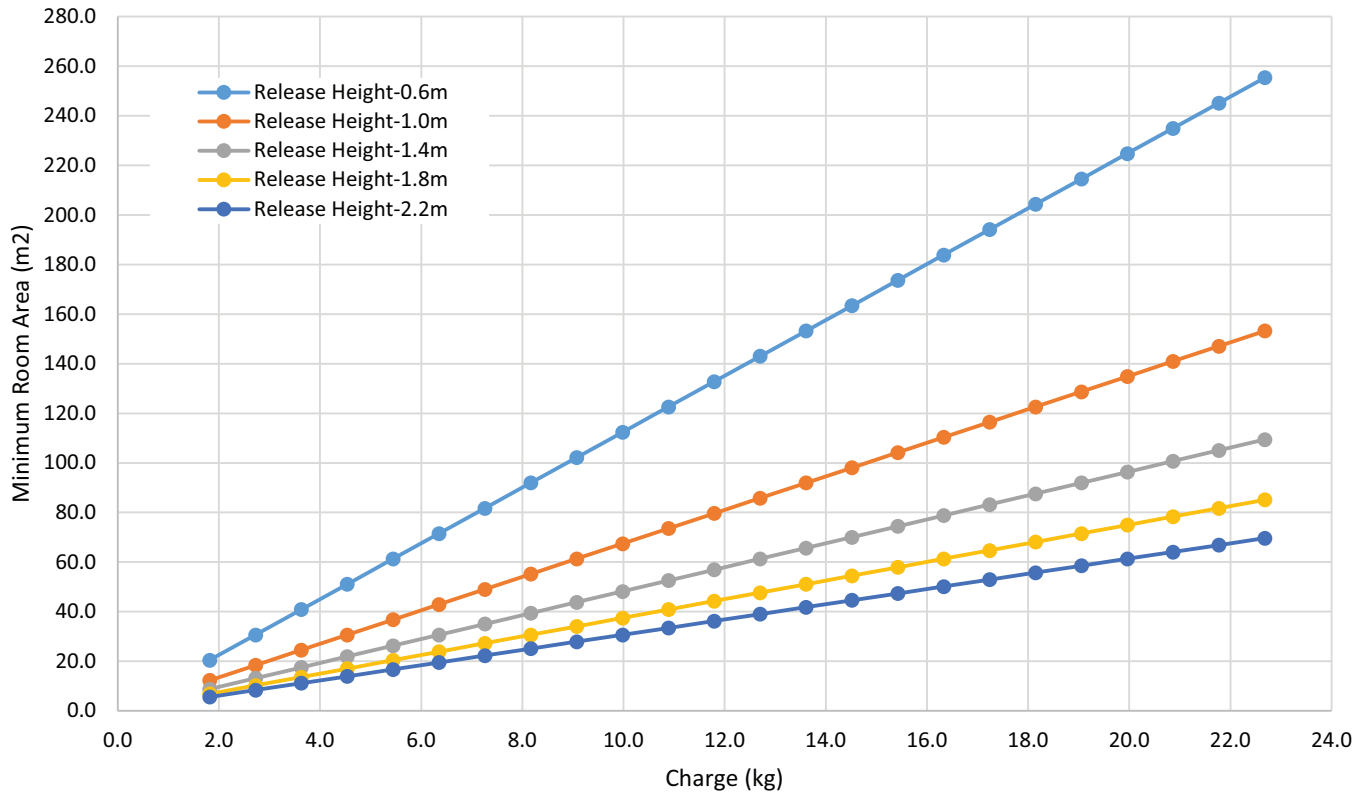

Figure 26. Charge vs min room area (SI) – R-454B refrigerant

Charge vs Min Room Area (SI)





## A2L Information and Installation Requirements

Release height is the vertical distance from the floor to the lowest point in a space refrigerant would leak from first. The minimum value is 0.6 m from the floor. This point is

typically the bottom of free return openings or supply diffusers. For fully ducted units, the release height is 2.2 meters.

Figure 27. Charge vs min room area (IP) – R-32 refrigerant

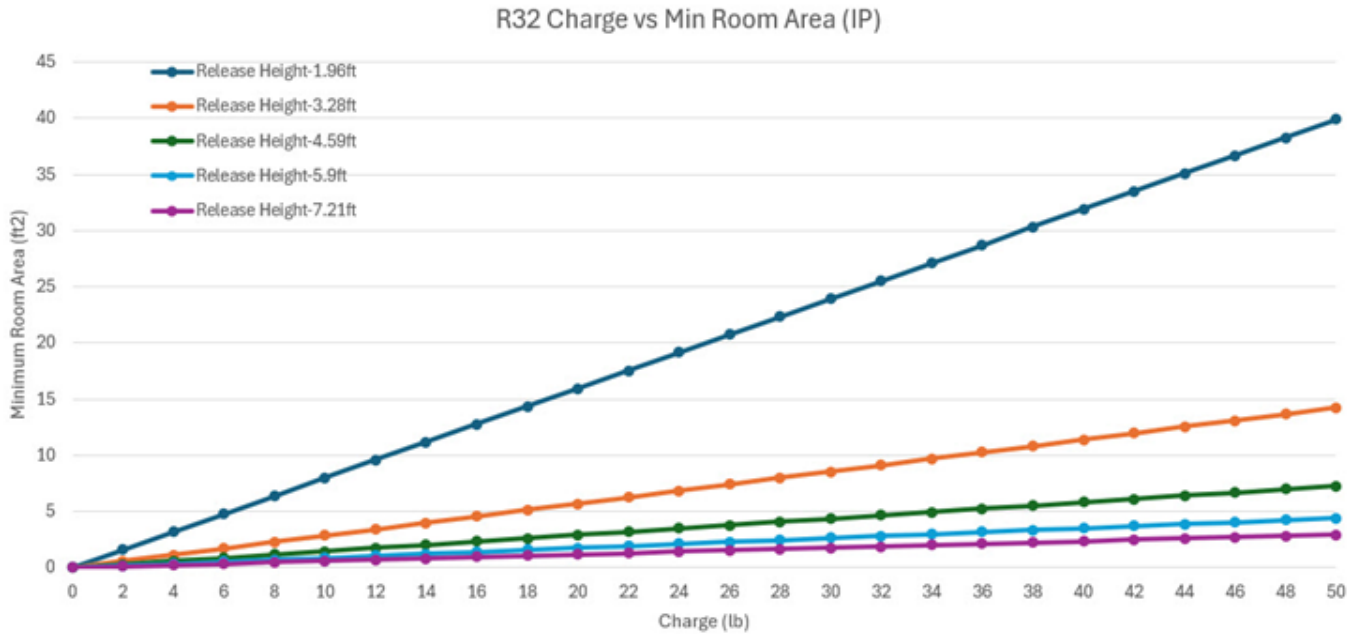
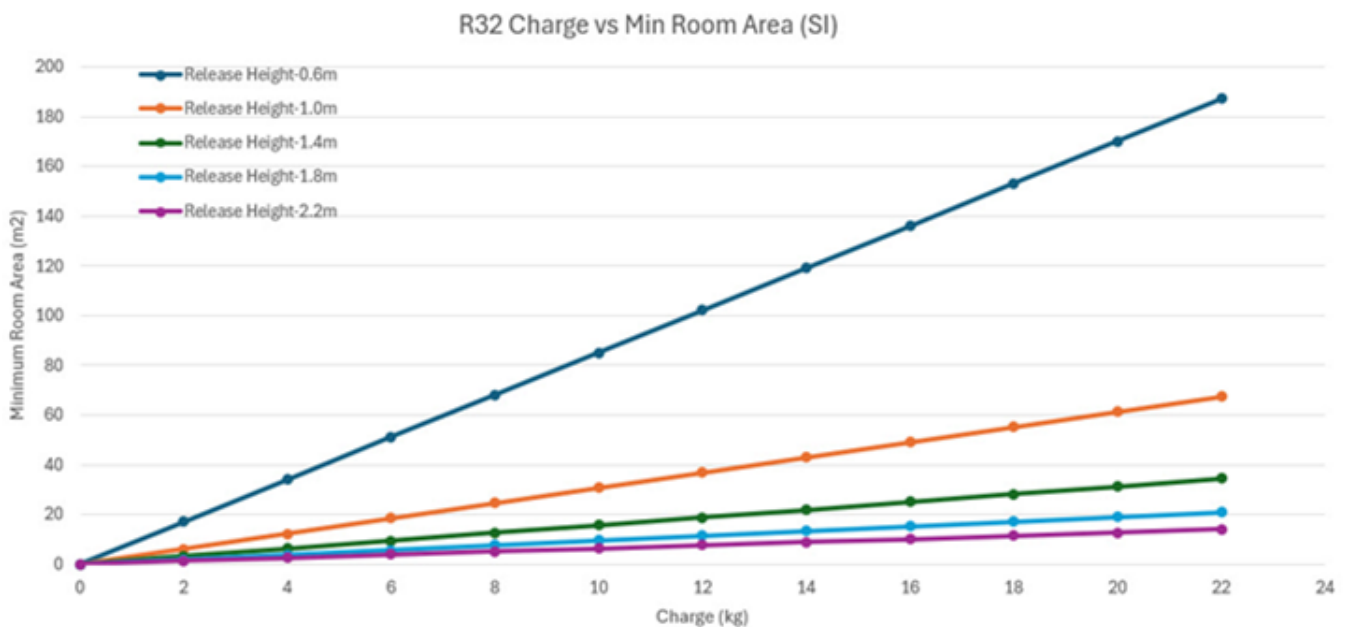

Figure 28. Charge vs min room area (SI) – R-32 refrigerant



### Minimum Room Area ( $A_{min}$ ) Adjustments

Use equation below to adjust the minimum room area, as applicable, based on the unit's installation height, altitude, and occupancy level it serves.

$$A_{min,adj} = \text{Nameplate } A_{min} \times \text{Altitude Adj} \times \text{Height Adj} \times F_{occ}$$

Multiply the altitude adjustment factor in the table below by  $A_{min}$  listed on the unit nameplate or in the Installation, Operation, and Maintenance (IOM) manual.

**Table 13. Altitude adjustment factor**

| Altitude (ft)        | Sea Level to 2000 | 2001 to 4000 | 4001 to 6000 | 6001 to 8000 | 8001 to 10000 | 10001 to 12000 | 12001 to 14000 | 14001 to 15000 | Over 15000 |
|----------------------|-------------------|--------------|--------------|--------------|---------------|----------------|----------------|----------------|------------|
| $A_{min}$ Adjustment | 1                 | 1.05         | 1.11         | 1.17         | 1.24          | 1.32           | 1.41           | 1.51           | 1.57       |

In addition,  $A_{min}$  can be adjusted if the unit is installed in a room at a height that is higher than the minimum height shown on the unit. To adjust  $A_{min}$ , multiply by the ratio of the unit minimum release height (in meters) / actual release height (in meters). Use 0.6 m in the ratio for unit minimum installation heights less than or equal to 0.6 m.

For institutional occupancies, ASHRAE Standard 15 applies an additional adjustment factor  $F_{occ}$  to the amount of a charge allowed in a space. To calculate the adjusted  $A_{min}$  for institutional occupancies, multiply the  $A_{min}$  on the nameplate by two.

**EXAMPLE 1: 20 Ton Packaged Rooftop Multi-Zone VAV System Serving an Institutional Occupancy Space**

The packaged unit serves 7600 ft.<sup>2</sup> of a nursing home located at an altitude of 4000 ft. The unit has two equally charged 10 ton refrigeration circuits. Each circuit has 12 lbs of refrigerant with a minimum room area requirement of 180 ft.<sup>2</sup> with a 2.2 m release height.

$$TA_{min.adj} = 180 \text{ ft.}^2 \times 1.05 \times 2 = 378 \text{ ft.}^2$$

No additional ventilation is required.

**EXAMPLE 2: 10 Ton Split System Serving a Single Commercial Occupancy Space**

The split system serves a 1500 ft.<sup>2</sup> manufacturing space at 5000 ft. altitude. The final installed charge of the single circuit 10 ton unit is 20 lb. The unit has an open return with a release height of 1 m and ducted supply air. The unit  $A_{min}$  is 660 ft.<sup>2</sup>.

$$A_{min.adj} = 660 \text{ ft.}^2 \times 1.11 = 733 \text{ ft.}^2$$

No additional ventilation is required.

### Determining Room Area (A or TA)

The room area (A) is the room area enclosed by the projection to the floor of the walls, partitions, and doors of the space that the equipment serves. For ducted systems, total room area (TA) of all rooms connected by ducts, may be used instead of A.

Rooms connected by drop ceilings only are not considered a single room.

Rooms on the same floor of the building, and connected by an open passageway, can be considered part of the same room if the passageway is a permanent opening, extends to the floor and is intended for people to walk through.

Adjacent rooms on the same floor of the building and connected by permanent openings in the walls and/or doors between rooms (including gaps between the wall and

the floor), can be considered part of the same room if the openings meet the following criteria.

- The opening is permanent and cannot be closed.
- Openings extending to the floor, such as door gaps, need to be at least 20 mm above the floor covering surface.
- Natural ventilations opening areas must meet the requirements of ANSIASHRAE Standard 15-2022, Section 7.2.3.2.

Rooms that are connected by a mechanical ventilation system can be considered a single room area if the mechanical ventilation system meets the requirements of ANSIASHRAE Standard 15-2022, Section 7.6.4.

### Leak Detection System (Refrigerant charge greater than 3.91 lb of R-454B or 4.04 lb of R-32 per circuit)

The leak detection system consists of one or more refrigerant detection sensors. When the system detects a leak, the following mitigation actions will be initiated until refrigerant has not been detected for at least 5 minutes:

- Energize the supply fan(s) to deliver a required minimum amount of circulation airflow.
- Disable compressor operation.
- Provide an output signal to fully open all zoning dampers, such as VAV boxes.
- Provide an output to energize additional mechanical ventilation (if needed).
- Units without airflow proving will disable electric heat sources.

Building fire and smoke systems may override this function.

If the refrigerant sensor has a fault, is at the end of its life, or is disconnected, the unit will initiate the mitigation actions. Mitigation actions may be verified by disconnecting the sensor.

The refrigerant sensors do not need service. Use only manufacturer-approved sensors when replacement is required.



## **Field Piping Installation and Charging**

When refrigerant piping is routed indoors, protect from physical damage in operation or service, and verify installation complies with national and local codes. All joints must be accessible for inspection prior to being covered.

Follow the Refrigerant Charging procedure. Prior to refrigerant charging, check field-made indoor joints for leaks using an instrument with a sensitivity of 5 grams per year refrigerant. Pressurize the system to 25% of the maximum allowable pressure. Verify no leaks are detected.

## Pipe Cabinet – R-32 Installation with a Vertical Unit Vent

For R-32 installations, a piping compartment must be used to house the LEV kit (not shown below) and its sensor.

The vertical unit vent will have the necessary components needed for installation located in the unit's end cabinet, including:

- Second refrigerant leak-detection sensor for the piping compartment (per UL/CSA 60335-2-40)
  - Bracket and screws for mounting the additional leak sensor to the piping compartment's back panel
  - Harness extension to connect the piping-compartment sensor to the primary unit sensor
  - Installation instructions
1. Install the pipe cabinet, aligning the circular holes and the perforated holes on the right side of the cabinet with the rectangular hole on the left side of the vertical unit vent.

2. Install the sensor bracket within the pipe cabinet near the bottom of the cabinet using the pre-drilled holes.
3. Attach the sensor to the bracket.
4. Unplug the sensor within the unit and use the harness extension. The shorter end will plug into the sensor within the unit and the longer end will go through the circular hole through the unit and the cabinet.

**Notes:**

- *The LEV Kit must be installed inside the pipe cabinet and connected to the refrigerant coil within the main unit.*
- *The pipe cabinet and unit **must** be flush with the wall as it is being installed.*
- *According to ASHRAE addendum 15, the sensor within the piping compartment and the sensor within the main unit must be able to perform mitigation actions in the presence of a refrigerant leak after installation is completed.*

**Figure 29. VUV with pipe cabinet**

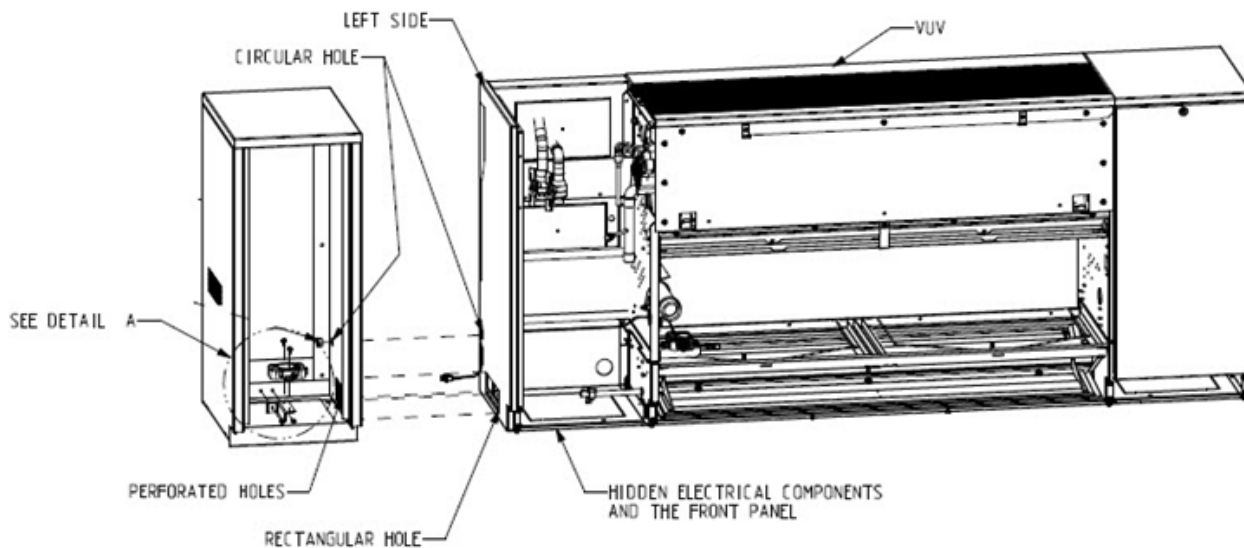

**Figure 30. Detail A**

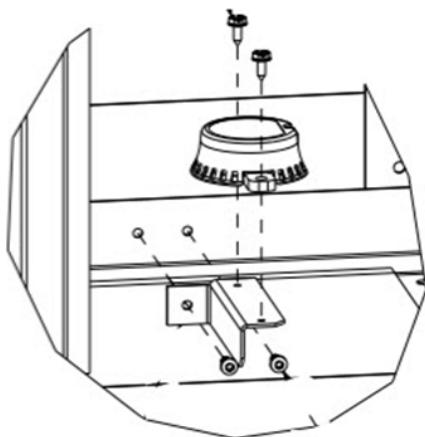



# Installation - Controls

## Control Options

Available control options:

- Customer-supplied terminal interface (CSTI)
- Symbio™ 400-B controller with Air-Fi® Wireless Communications Interface

### Fan Speed Control with Standard Adapter Board

The fan speed control is available for units that do not have Trane factory-mounted control packages. This variable fan speed option is low-voltage and has three 24-volt relays using a factory-wired transformer and relays to control the fan motor.

The adapter allows direct customer interfacing through the use of terminal strips. Standard interfacing includes:

- Variable speed (0–10V) inputs.
- The standard adapter board eliminates many separate wiring harnesses in the panel and allows simple, mistake-proofed single-plug interfacing of:
  - VelociTach™ motor control board
  - Transformers
  - Motors
  - Valves
  - Dampers
  - Electric heat control
  - Fan speed control

Figure 31. Fan speed control



Figure 32. Standard adapter board

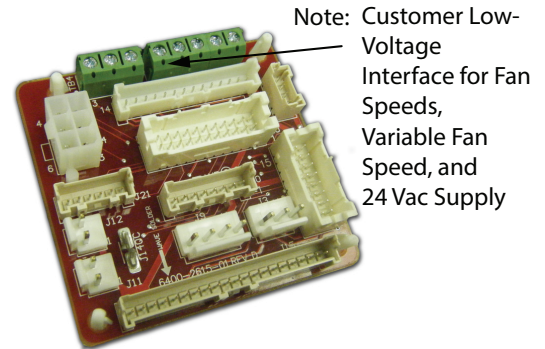

### Customer Supplied Terminal Interface (CSTI)

The control interface is intended to be used with a field-supplied, low-voltage thermostat or controller. The control box contains a relay board which includes a line voltage to 24-volt transformer, quiet contactors (for electric heat units), and an optional disconnect switch. All end devices are wired to a low-voltage terminal block and are run-tested, so the only a power connection and thermostat connection is needed to commission the unit.

Entering water temperature sensor is factory mounted on the supply water pipe. If there are problems sensing accurate temperature for non-flowing water, move entering water temperature sensor as far down the supply line as possible to get accurate water temperatures.

Figure 33. CSTI adapter board and field connections

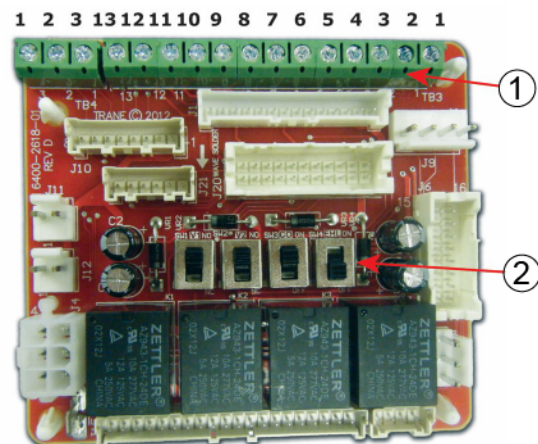

1. Customer Low-Voltage Interface for Fan Speeds, Variable Fan Speed, and 24 Vac Supply, valve control, EH control, damper control, condensate overflow status.
2. Valve(s), Electric Heat, and Changeover Configuration Switches (Factory-Set).

- |                   |                          |
|-------------------|--------------------------|
| 1. VSP 10V        | 6. V1Op/Cooling          |
| 2. VSP 0–10V      | 7. V1C1 (not std)        |
| 3. VSP DC COM     | 8. Not used              |
|                   | 9. Not used              |
| 1. 24 Vac B (hot) | 10. V2Op/EH1St/Heating   |
| 2. 24 Vac Y (gnd) | 11. V2C1/EH2St (not std) |
| 3. High           | 12. Damper Open          |
| 4. Medium         | 13. Dmp Cl (not std)     |
| 5. Low            |                          |

The CSTI adapter board provides all the hookups of the standard adapter board, but in addition provides hookups for valve control (main and auxiliary coils), electric heat control and damper control.

Screw terminal blocks provide convenient access to fan controls and to end device control. In addition, a courtesy 10 Vdc supply is provided for use with an external potentiometer or rheostat. The 10 Vdc supply supports up to 10 mA draw.

TB3 (right 13 positions) is normally used to provide:

- 24 Vac supply to a wall fan speed switch or
- 24 Vac supply to a field-installed unit-mounted controller, or a wall-mounted controller or thermostat
- Inputs (returns) for thermostatic fan control: High, Medium, and Low
- Inputs (returns) for cooling/heating requests
- Inputs (returns) for electric heat requests
- Inputs (returns) for damper operation requests

TB4 (left three positions) is normally used to control the system with a 0 to 10 Vdc input from a thermostat/controller with a variable speed output, or a fan control rheostat.

The terminal block functional assignments and polarity are shown for reference only, and the schematics that ship with each unit should be consulted before wiring. Wiring assignments are configured for each unit.

### CSTI Adapter Board Configuration

**⚠ CAUTION**

**Burn Hazard!**  
 Failure to follow this instruction could result in the unit overheating and becoming hot to the touch, which could result in minor or moderate injury, and/or equipment damage.  
 On electric heat units, certain parameter values are locked out to prevent overheating of the unit. These functions will appear to be saved; however, they will not be accepted if the Electric Heat Protection setting is “On”. Do not change the Electric Heat Protection setting to “Off” and make changes to the protected settings unless you are programming an unconfigured service replacement board to match the unit settings on an ECM configuration label.

For CSTI units, the board mounted switches have to be set appropriately to enable the desired functionality.

**Figure 34. CSTI adapter board: board-mounted switches**

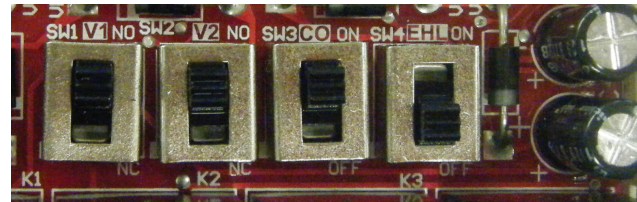

**Table 14. CSTI adapter board: switch functions**

| Switch (L-R)                         | SW1                       | SW2                       | SW3                      | SW4                                |
|--------------------------------------|---------------------------|---------------------------|--------------------------|------------------------------------|
| Function                             | Valve one operation logic | Valve two operation logic | Change-over Function     | Electric Heat/Fan Proving Function |
| UP position (towards terminal strip) | Normally Open Valve       | Normally Open Valve       | Change-over Function ON  | Electric Heat/Fan Proving Function |
| DOWN position (towards black relays) | Normally Closed Valve     | Normally Closed Valve     | Change-over Function OFF | Electric Heat/Fan Proving Function |



## Installation - Controls

### Notes:

- All switches are factory-set based on customer configuration of the unit model number. The unit will function correctly as shipped; however, the switch functions and positions are depicted for customer convenience and for service and troubleshooting aids.
- SW3 and SW4 work in conjunction with settings on the ECM engine controller. Simple activation of changeover and electric heat lockout function may not work correctly unless the ECM engine board is configured to perform these functions.
- Customers are advised to locate the changeover coil temperature sensor on the bypass line if possible, to avoid measuring standing water temperature.
- If a 4-pipe unit with changeover function is selected, the heating input will drive the main coil if hot water is detected, but will always drive the auxiliary coil or electric heat (where available).
- Where electric heat is available with a changeover coil, the electric heat is factory-configured to be deactivated if there is hot water available and if there is a fan failure.

The CSTI board comes with courtesy valve inversion relays that allow both normally open and normally closed 2-position valves to be used with simple thermostats that do not have the configurability to adapt to the customer choice of valves. Independent switches, SW1 and SW2, are provided for 2-pipe or 4-pipe units, or 2-pipe units with an optional reheat coil. The functions of SW1 and SW2 is downstream of the changeover function (SW3 and ECM engine board). Decisions made by the changeover circuits will be flowed to the inversion circuits, if they are selected.

SW3 enables or disables the changeover function for 2-pipe changeover coil units, or 4-pipe units where the coil has both a heating/cooling circuit and a heating circuit piped internally. If SW3 is turned off, the changeover function will be disabled, and the unit will then be configured as a cooling only coil, a heating only coil, or a combination of cooling only/heating only coil. Thus, customer cooling requests will drive the main valve, and heating requests will drive the auxiliary valve.

The changeover function is designed to work with customer controllers that request heating or cooling (based on customer request), but have coil water temperatures that are changed over from heating to cooling (or cooling to heating) depending on the season and the building equipment available. Customer thermostats MUST be hooked to the correct terminal strip locations (V1 and V2) for the changeover function to work.

### Cooling

In general, the (CSTI) changeover function will provide cooling if:

1. A unit is factory configured with a changeover coil (cooling/heating) as the only coil or as the main coil portion.
2. SW3 on the CSTI adapter board is turned on, and the  $FP_{RU}$  parameter set to  $E_{HL}$  or  $E_{HF5}$  to use the changeover functions.
  - a.  $E_{HL}$  parameter should be chosen if the unit has a changeover coil without electric heat.
  - b.  $E_{HF5}$  parameter should be chosen if the unit has a changeover coil with electric heat. Generally, this will perform the same as the  $E_{HL}$  parameter but will in addition, disable the heating function on electric heat and on the changeover coil heat if there are fan failures. The auxiliary heating coil valve will continue to respond to customer heating requests.
3. The ECM engine has sensed that there is cold water available on the supply/bypass line for the changeover coil. In this case, cold water is inferred by the ECM engine if:
  - a. A 10K NTC thermistor (similar to Trane part number X13790374010) is wired properly to the engine board, through the crossover cables and CSTI adapter boards.
  - b. The input impedance of the thermistor circuit must be set correctly (the  $R_{IPU}$  parameter should be set to  $r_n$  for CSTI units).
  - c. The temperature sensed is lower than the  $R_{i2i}$  parameter.
  - d. The  $R_{i2b}$  parameter is higher than the  $R_{i2i}$  parameter.
  - e. The temperature is not in the dead-band between the  $R_{i2b}$  parameter and the  $R_{i2i}$  parameter (in this case, previous state will be retained).
4. The customer thermostat is properly hooked up the input strip 1TB3, and is requesting cooling input (V1) based on the customer cooling setpoint being lower than the space temperature.

### Heating

In general, the (CSTI) changeover function will provide heating if:

1. A unit is factory-configured with a changeover coil (cooling/heating) as the only coil or as the main coil portion.
2. SW3 on the CSTI adapter board is turned on, and the  $FP_{RU}$  parameter set to  $E_{HL}$  or  $E_{HF5}$  to use the changeover functions.
  - a.  $E_{HL}$  parameter should be chosen if the unit has a changeover coil without electric heat.
  - b.  $E_{HF5}$  parameter should be chosen if the unit has a changeover coil with electric heat. Generally, this will perform the same as the  $E_{HL}$  parameter but will in addition, disable the heating function on electric heat and on the changeover coil heat if there are

fan failures. The auxiliary heating coil valve will continue to respond to customer heating requests.

3. The ECM engine has sensed that there is hot water available on the supply/bypass line for the changeover coil. In this case, hot water is determined if:
  - a. A 10K NTC thermistor (similar to Trane part number X13790374010) is wired properly to the engine board, through the crossover cables and CSTI adapter boards.
  - b. The input impedance of the thermistor circuit must be set correctly (the  $R_{IPU}$  parameter should be set to  $i_n$  for CSTI units).
  - c. The temperature sensed is higher than the  $R_{i2b}$  parameter.
  - d. The  $R_{i2b}$  parameter is higher than the  $R_{i2i}$  parameter.
  - e. The temperature is not in the dead-band between the  $R_{i2b}$  parameter and the  $R_{i2i}$  parameter (in this case, previous state will be retained).
4. The customer thermostat is properly hooked up the input strip 1TB3, and is requesting heating input (V2) based on the customer heating set point being higher than the space temperature.
5. The heating input on 1TB3 will drive the main changeover coil IF conditions 1–4 are satisfied, but will always drive the auxiliary coil valve (if present). Electric heat will be locked out (where present) if hot water is available since SW4 will be factory set to **ON** in these units.

SW4 selects the electric heat lockout function, where we will lock out the electric heat circuit based on either:

1. The presence of hot water in the changeover coil section (if the  $FP_{ru}$  parameter is set to  $EH_L$ ).
2. Abnormal behavior of the fan/s (if the  $FP_{ru}$  parameter is set to  $F_{n5t}$ ).
3. Or a combination of both the presence of hot water or abnormal behavior of the fan/s (if the  $FP_{ru}$  parameter is set to  $EHF5$ ).
4. The preceding three examples depend on the inference of the engine board that hot water is present. In this case, hot water is determined if:
  - a. The temperature sensed is higher than the  $R_{i2b}$  parameter.
  - b. The  $R_{i2b}$  parameter is higher than the  $R_{i2i}$  parameter.
  - c. The temperature is not in the dead-band between the  $R_{i2b}$  parameter and the  $R_{i2i}$  parameter (in this case, previous state will be retained).
  - d. The input impedance of the thermistor circuit must be set correctly (the  $R_{IPU}$  parameter should be set to  $i_n$  for CSTI units).

## Symbio™ 400-B Controller

The Symbio™ 400-B single-zone VAV controller can be used in a stand-alone application or as part of a Tracer® control system.

In the stand-alone configuration, Symbio 400-B receives operation commands from the zone sensor and/or the entering water temperature sensor (on auto changeover units). The reading from the entering water temperature sensor and determines if the unit is capable of cooling or heating. The zone sensor module is capable of transmitting the following information to the controller:

- Timed override on/cancel request
- Zone setpoint
- Current zone temperature
- Fan mode selection (off-auto-high-med-low)

For optimal system performance, units can operate as part of a Tracer® SC building automation system. The controller is linked directly to the Tracer SC via a twisted pair communication wire, requiring no additional interface device (i.e., a command unit). The Tracer control system can monitor or override Symbio 400-B control points. This includes such points as temperature and output positions.

**Note:** For more detailed information, refer to *Symbio™ 400-B/500 Programmable Controllers For Blower Coil, Fan Coil, and Unit Ventilator - Installation, Operation, and Maintenance (BAS-SVX093\*-EN)*.

## Communication Wire Specifications

All wiring must comply with the National Electrical Code (NEC™) and local electrical codes.

Field-supplied BACnet® MS/TP link wiring must be installed in compliance with NEC and local codes. The wire must be low-capacitance, 18-gauge, stranded, tinned-copper, shielded, twisted-pair.

**Note:** For more details, refer to *Wiring Guide: Unit Controller Wiring for the Tracer® SC System Controller (BAS-SVN03\*-EN, or the most recent revision)*.

## General Wiring Guidelines

**Figure 35. Connecting wires to terminal**

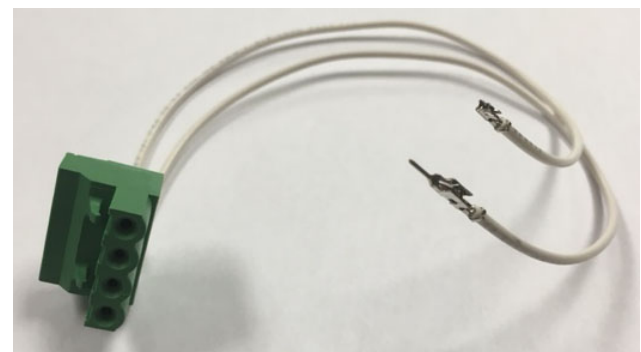

To connect wires to the Symbio™ 400-B controller or the expansion modules:

1. Strip the wires to expose 0.28 inch (7 mm) of bare wire.
2. Insert the wire into a terminal connector.
3. Tighten the terminal screw to 0.5 to 0.6 N-m (71 to 85 ozf-in or 4.4 to 5.3 lbf-in.).
4. Tug on the wires after tightening the screws to ensure all wires are secure as shown on the right.

## Setting the Address

**Note:** Final addresses are subject to change based on final job requirements. For pre-addressed controllers and WCI's from the factory, verify addresses are set correctly prior to powering the device.

The rotary address dials on the Symbio™ 400-B controller serve one or two purposes depending upon the network: they are always used for the MAC Address, which is sometimes all or part of the BACnet® Device ID.

Use a 1/8 inch (3.2 mm) flathead screwdriver to set rotary address dials. Dials rotate in either direction.

**Figure 36. Setting rotary address dials**

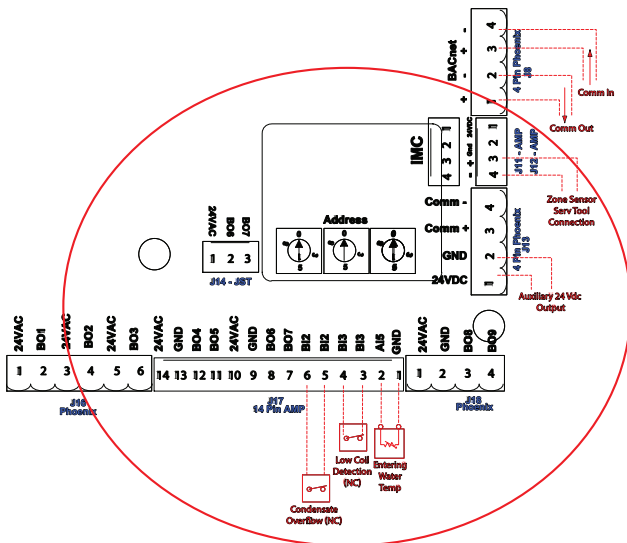

## MAC Address

The MAC Address is required by the RS-485 communication protocol on which BACnet® operates. A Symbio 400-B controller can use a MAC Address from 001 to 120.

**Important:** Each device on the link must have a unique MAC Address/Device ID. The controller rotary addresses should be sequentially set, with no gaps in the numbering, starting with 001 on each link (for example 001, 002, 003, 004 and so on). A duplicate address or a 000 address setting will interrupt communications and cause the Tracer® SC device installation process to fail.

## BACnet® Device ID

The BACnet Device ID is required by the BACnet® network. Each device must have a unique number from 001 to 4094302.

## BACnet networks without a Tracer® SC system controller

On BACnet networks without a Tracer SC system controller, the Device ID can be assigned one of two ways:

- It can be the same number as the MAC Address, determined by the rotary address dials on the Symbio 400-B controller. For example, if the rotary address dials are set to 042, both the MAC Address and the BACnet Device ID are 042.
- It can be soft set using the Tracer TU service tool. If the BACnet Device ID is set using the Tracer TU service tool, the rotary address dials only affect the MAC Address, they do not affect the BACnet Device ID.

## BACnet networks with a Tracer SC system controller

On BACnet networks with a Tracer SC system controller, the Device ID for the Symbio 400-B controller is always soft set by the system controller using the following scheme illustrated below.

**Note:** The BACnet Device ID is displayed as the Software Device ID on the Tracer TU Controller Settings page in the Protocol group.

**Figure 37. Example of BACnet® link wiring with multiple Symbio™ 400-B controllers**

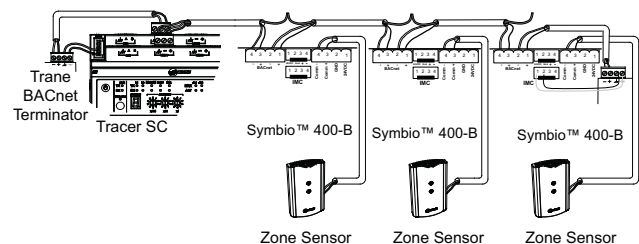

## Power Supply

Please read all of the warnings, cautions, and notices below before proceeding with this section.

**⚠ WARNING**

**Hazardous Voltage!**

Failure to disconnect power before servicing could result in death or serious injury.

Disconnect all electric power, including remote disconnects before servicing. Follow proper lockout/tagout procedures to ensure the power can not be inadvertently energized. Verify that no power is present with a voltmeter.

### ⚠ WARNING

#### Proper Ground Connection Required!

Failure to follow instructions below could result in death or serious injury.

After installation, ensure that the 24 Vac transformer is grounded through the controller. Measure the voltage between chassis ground and any ground terminal on the controller. Expected result: Vac <4.0 volt.

### NOTICE

#### Equipment Damage!

Sharing 24 Vac power between controllers could result in equipment damage.

A separate transformer is recommended for each Symbio 400-B controller. The line input to the transformer must be equipped with a circuit breaker sized to handle the maximum transformer line current.

If a single transformer is shared by multiple Symbio 400-B controllers:

- The transformer must have sufficient capacity.
- Polarity must be maintained for every Symbio 400-B controller powered by the transformer.

**Notes:** If the polarity is inadvertently reversed between two controllers powered by the same transformer, a difference of 24 Vac will occur between the grounds of each controller, which can result in:

- Partial or full loss of communication on the entire BACnet MS/TP link.
- Improper function of the Symbio 400-B controller outputs.
- Damage to the transformer or a blown transformer fuse.

### Transformer Recommendations

A 24 Vac power supply must be used for proper operation of the binary inputs, which requires 24 Vac detection. In addition, the spare 24 Vac outputs may be used to power relays and TRIACS.

- AC transformer requirements: *UL listed, Class 2 power transformer, 24 Vac ±15%, device max load 24 VA. The transformer must be sized to provide adequate power to the controller (12 VA) and outputs (maximum 12 VA per binary output).*
- CE-compliant installations: *The transformer must be CE marked and SELV compliant per IEC standards.*

### Wiring Requirements

To ensure proper operation of the Symbio 400-B controller, install the power supply circuit in accordance with the following guidelines:

- A dedicated power circuit disconnect switch must be near the controller, easily accessible by the operator,

and marked as the disconnecting device for the controller.

- 18 AWG (0.823 mm<sup>2</sup>) copper wire is recommended for the circuit between the transformer and the controller.

**Important:** The controller must receive AC power from a dedicated power circuit; failure to comply may cause the controller to malfunction. Do not run AC power wires in the same wire bundle with input/output wires; failure to comply may cause the controller to malfunction due to electrical noise.

### Connecting Wires

Figure 38. Grounding the controller

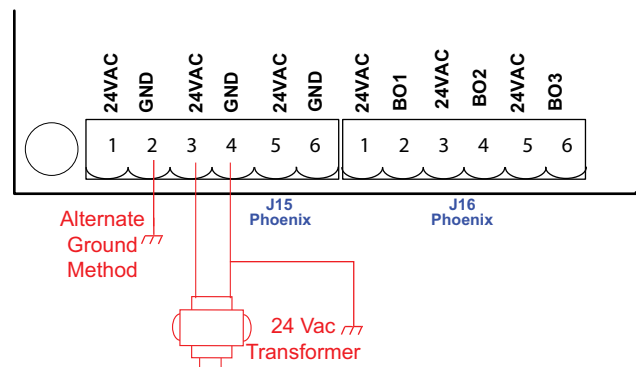

To connect the wires:

1. Disconnect power to the transformer.
  2. Connect the 24 Vac secondary wires from the transformer to the 24 Vac terminals and terminals on the Symbio™ 400-B controller (refer to the illustration below).
  3. Do one of the following to ensure the controller is adequately grounded:
    - Connect a grounding pigtail at some point along the secondary wire that runs between the controller terminal and the transformer.
    - Ground one of the terminals on the controller to the enclosure (if the enclosure is adequately grounded) or to an alternate earth ground.
- Note:** A pigtail connection may be necessary between earth ground and/or enclosure ground if the device is not grounded through one leg of the transformer wiring.

### Power ON Check

To perform a Power ON check:

1. Verify that the 24 Vac connector and the chassis ground are properly wired.
2. Remove the lockout/tagout from the line voltage power to the electrical cabinet.



## Installation - Controls

3. Energize the transformer to apply power to the Symbio 400-B controller.
  4. Observe the Symbio 400-B controller when power is applied to verify the power check sequence as follows:
    - a. The power LED lights red for 1 second
    - b. The power LED lights green
- If the sequence above is completed as described, the controller is properly booted and ready for the application code.

If the power LED flashes red, a fault condition exists.

The controller is mounted, pre-wired, and pre-programmed to selected control components best suited for room comfort. For more information on the Symbio™ 400-B unit controller operation and service, refer to *Symbio™ 400-B/500 Programmable Controllers For Blower Coil, Fan Coil, and Unit Ventilator - Installation, Operation, and Maintenance* (BAS-SVX093\*-EN).

## Air-Fi® Wireless Communications System

For more detailed information on Air-Fi® Wireless Communications system and devices, see:

- *Air-Fi® Wireless System - Installation, Operation, and Maintenance* (BAS-SVX40\*-EN).
- *Air-Fi® Wireless System - Product Data Sheet* (BAS-PRD021\*-EN).
- *Air-Fi® Wireless Network Design - Installation, Operation, and Maintenance* (BAS-SVX55\*-EN).

## Air-Fi® Wireless Communications Interface (WCI)



A factory-installed Air-Fi® Wireless Communications Interface (WCI) provides wireless communication between the Tracer® SC and Tracer® unit controllers. The Air-Fi® WCI is the perfect alternative to a Trane BACnet® wired communication link. Eliminating the communication wire between terminal products, space sensors, and system controllers has substantial benefits:

- Reduced installation time and associated risks.
- Completion of projects with fewer disruptions.
- Easier and more cost-effective re-configurations, expansions, and upgrades.

## Air-Fi® Wireless Communications Sensor (WCS)



Communicates wirelessly to a Tracer® unit controller. A WCS is an alternative to a wired sensor when access and routing of communication cable are issues. A WCS allows flexible mounting and relocation.

## Wireless Zone Sensor (WZS) Set



A wireless zone sensor (WZS) set (sensor and receiver) communicates wirelessly to a Tracer® unit controller. A wireless zone sensor set is an alternative to a wired sensor when access and routing of communication cable are issues. The sensor allows flexible mounting and relocation.

**Note:** A wireless zone sensor set is not compatible with an Air-Fi® wireless system.

The Wireless Comm Interface (WCI) enables wireless communication between system controls, unit controls, and wireless sensors for the new generation of Trane control products. The WCI replaces the need for communication wire in all system applications.

**Notes:** For more detailed information, refer to:

- *Air-Fi® Wireless System - Installation, Operation and Maintenance manual (BAS-SVX40\*-EN).*
- *Air-Fi® Network Design - Installation, Operation and Maintenance manual (BAS-SVX55\*-EN).*

## Zone Sensor Options

Control sensor options include both unit-mounted (factory-installed) and wall-mounted sensors. Tracer® controller options available for the zone sensors are:

- Symbio™ 400-B delivers single zone VAV control in a stand-alone operation or as part of a building automation system using BACnet® communications.

Zone sensors have an internal thermistor and operate on 24 Vac. Options with setpoint knobs are available in Fahrenheit or Celsius.

**Figure 39. Unit-mounted zone sensor (SP, OCC/UNOCC, OALMH)**



**Figure 40. Wall-mounted zone sensor (SP, OCC/UNOCC, OALMH)**



**Figure 41. Wall-mounted display sensor (SP, OCC/UNOCC, OALMH)**



**Figure 42. Unit-mounted fan speed control, wall-mounted zone sensor (SP, OCC/UNOCC, COMM)**



**Figure 43. Wall-mounted wireless zone sensor (WZS), unit-mounted receiver (SP, OCC/UNOCC)**





## Installation - Controls

**Figure 44. Wall-mounted wireless display sensor, unit-mounted receiver (SP, OALMH)**



**Figure 45. Air-Fi® WCS, Air-Fi® WCI (SP, OALMH0 (Symbio™ 400-B only))**



## Zone Sensor Installation

### Location Considerations

When selecting a location for the zone sensor, avoid the following:

- Dead spots, such as behind doors, projection screens, or in corners that do not allow free air circulation.
- Air drafts from stairwells, outside doors, or unsectioned hollow walls.
- Airflow from adjacent zones or other units.
- Unheated or uncooled spaces behind the controller, such as outside walls or unoccupied spaces.
- Concealed pipes, air ducts, or chimneys in partition spaces behind the controller.
- Areas in the direct airstream of air diffusers.

- Exterior walls and other walls that have a temperature differential between the two sides.
- Areas that are close to heat sources such as sunlight, appliances, concealed pipes, chimneys, or other heat-generating equipment.
- Walls that are subject to high vibration.
- Areas with high humidity.
- High traffic areas (to reduce accidental damage or tampering).
- Metal barriers between the receiver and the sensor (for example, plastered walls with metal lath or metal roof decks).
- Thick, solid concrete walls between the receiver and the sensor.

### Location Considerations for Wireless Zone Sensors

Placement of the sensor is critical to proper operation (the receiver is factory mounted on fan-coil units). For most installations, barriers limit proper radio signal strength more than distance. For best radio transmission range and reliability, mount the receiver and sensor in line of sight. Where this is not possible, try to minimize the number of barriers between the pair of devices. In general, sheetrock walls and ceiling tiles offer little restriction to the transmission range for the sensor is as follows:

- Open range: 2,500 ft. (packet error rate = 2%)
- Usable range: 200 ft.
- Typical range: 75 ft.

### Height Requirements

It is recommended that you mount the back plate a maximum distance of 54-inches above the floor. If a parallel approach by a person in a wheelchair is required, reduce the maximum height to 48-inches.

**Note:** Consult section 4.27.3 of the 2002 ADA (Americans with Disability Act) guideline, and local building codes, for further details regarding wheelchair requirements.

### Mounting Surfaces

Using the hardware provided, mount the back plate of the sensor to a flat surface such as sheetrock or plaster, or an electrical junction box. The sensor must be mounted plumb for accurate temperature control and to ensure proper air movement through the sensor.

- If mounting onto sheetrock or plaster, use the plastic threaded anchors (pre-drilling holes is not usually necessary) and the two M3.5 × 20 mm mounting screws.
- For mounting onto an electrical junction box, use the two 6-32 × 3/4 in. screws.

Before beginning installation, consider the location considerations below. Also, refer to the unit wiring schematic for specific wiring details and point connections.

## Zone Sensor Dimensions

Refer the wall-mounted zone sensor dimensions in [Figure 46, p. 49](#). Position the sensor on an inside wall three to five feet above the floor and at least 18 inches from the nearest outside wall. Installing the sensor at a lower height may give the advantage of monitoring the temperature closer to the zone, but it also exposes the sensor to airflow obstructions. Ensure that air flows freely over the sensor.

**Figure 46. Wall-mounted wired and wireless zone sensor dimensions**

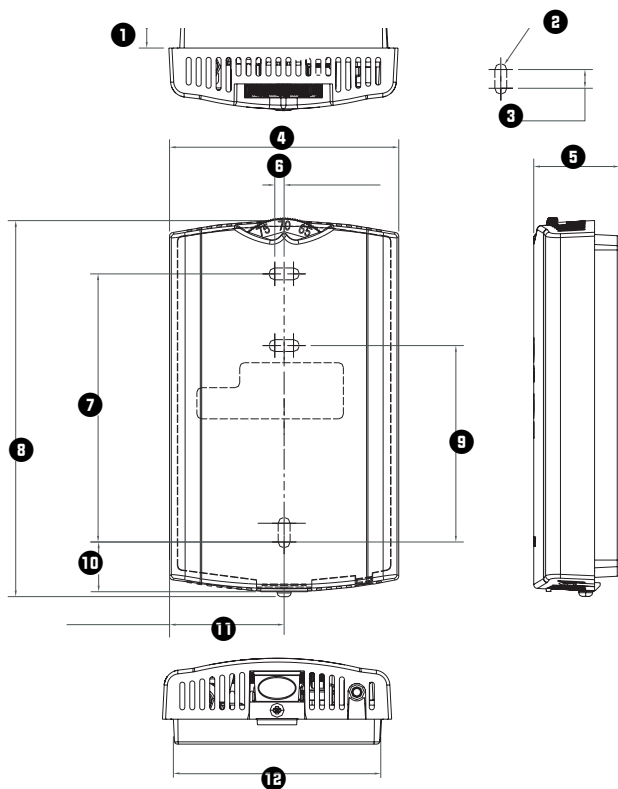

- |                        |              |
|------------------------|--------------|
| 1. 0.31 in.            | 7. 3.39 in.  |
| 2. TYP R.07 in. (R1.9) | 8. 4.68 in.  |
| 3. TYP 0.24 in.        | 9. 2.48 in.  |
| 4. 2.9 in.             | 10. 0.63 in. |
| 5. 1.08 in.            | 11. 1.45 in. |
| 6. 0.12 in.            | 12. 2.62 in. |

## Wired Zone Sensor

Follow the procedure below to install the wired zone sensor module.

1. Note the position of the setpoint adjustment knob and gently pry the adjustment knob from the cover using the blade of a small screwdriver.
2. Insert the screwdriver blade behind the cover at the top of the module and carefully pry the cover away from the base.
3. To mount the sensor back plate:
  - a. Hold the back plate against the mounting surface and mark the screw locations.
  - b. Secure the back plate against the mounting surface using included hardware.
4. To install the zone sensor module to a standard junction box:
  - a. Level and install a 2 × 4-in. junction box (installer supplied) vertically on the wall.
  - b. Pull the control wires through the cutout. Attach the module to the wall using the screws provided.
5. Strip the insulation on the interconnection wires back 0.25-inch and connect to TB1 (for wired sensors).
6. Screw down the terminal blocks (for wired sensors).
7. To replace the cover:
  - a. Hook the cover over the top of the back plate. Apply light pressure to the bottom of the cover until it snaps in place.
  - b. Install the security screw into the bottom of the cover (if desired).

**Figure 47. Mounting zone sensor security screw**

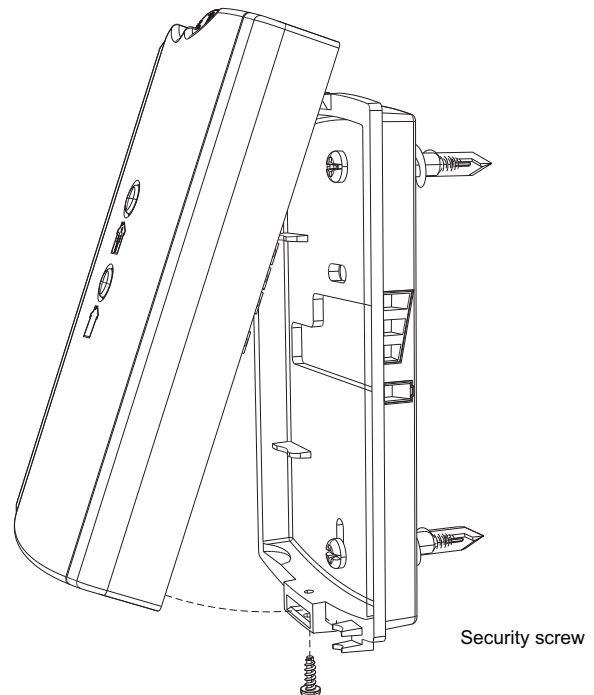

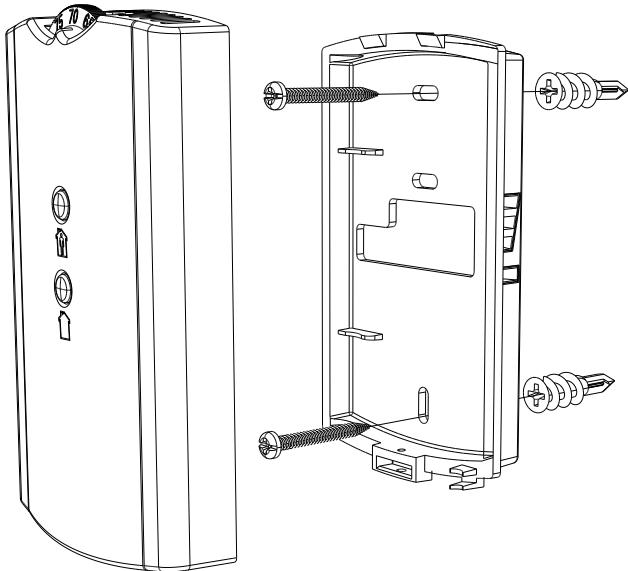
**Figure 48. Mounting zone sensor base plate**

## Wireless Zone Sensors

1. Note the position of the setpoint adjustment knob and gently pry the adjustment knob from the cover using the blade of a small screwdriver.
2. Insert the screwdriver blade behind the cover at the top of the module and carefully pry the cover away from the base.
3. To mount the sensor back plate: (see [Figure 48, p. 50](#))
  - a. Hold the back plate against the mounting surface and mark the screw locations.
  - b. Secure the back plate against the mounting surface using included hardware.
4. To replace the cover:
  - a. Hook the cover over the top of the back plate. Apply light pressure to the bottom of the cover until it snaps in place.
  - b. Install the security screw into the bottom of the cover if desired (see [Figure 47, p. 49](#)).

**Note:** For more detailed information for wireless sensors, see *Wireless Zone Sensors - Installation, Operation, and Maintenance (BAS-SVX04\*-EN)*.

## Receivers

**Note:** Receivers ship installed on the unit. To remove the receiver, press in the retention tabs on the underside of the receiver enclosure and push upward.

## Zone Sensor Setting

### Address Setting

The process of establishing communication between a receiver and sensor is referred to as association. The following limitations apply:

- Each associated receiver/sensor set that communicates within the reception range of the wireless system must have a unique address.

It is not possible to associate more than one sensor to a receiver, nor is it possible to associate more than one receiver to a sensor.

To associate a receiver and sensor, the two devices must have their rotary address switches set to the same address.

**Important:** Set the addresses before applying power to the receiver and before removing the insulation strip ([Figure 49, p. 51](#)) from the sensor.

To set the receiver and sensor addresses:

1. Using a small screwdriver, set the three rotary address switches (locations S1, S2, S3) on the receiver to an address between 001 and 999 (see [Figure 49, p. 51](#)). You do not have to remove the covers to access the rotary address switches.

**Note:** Do not use 000 as an address. An address of 000 returns the receiver outputs to their factory defaults (zone temperature and setpoint outputs: 72.5°F, removes all association knowledge, and prevents association with a sensor).

**Figure 49. Setting the rotary address switches on the receiver and the sensor**

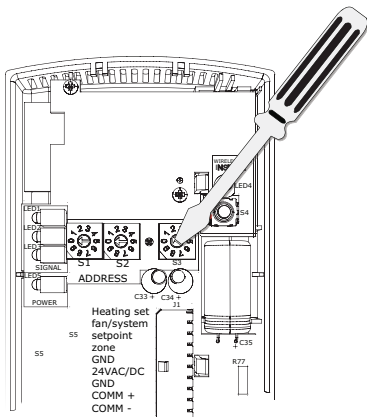

Receiver

Do not remove the insulation strip yet

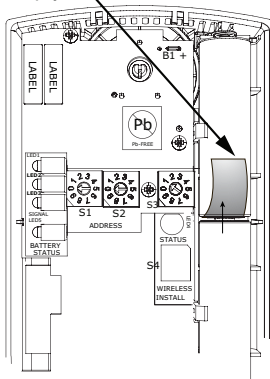

Sensor

2. Set the three rotary address switches (locations S1, S2, S3) on the sensor to the same address as the receiver (see Figure 49, p. 51).
 

**Note:** Do not use 000 as an address. An address of 000 removes all association knowledge, reverts the sensor to a low-power hibernation mode, and sends a disassociation request to the receiver.
3. Record the address and location of the receiver and sensor pair.

### Observing the Receiver for Readiness to Associate

After initial power up, the receiver conducts a channel scan for 20 seconds. During this time, the receiver selects from 16 available channels the clearest channel on which to operate. LED1, LED2, and LED3 flash rapidly in succession (roundrobin style) while the channel scan is in progress, as shown in part 1 of the illustration.

**Important:** Do not attempt association (leave the insulation strip in place) until the channel scan is finished.

After the channel scan is finished, LED3 begins blinking (one-blink pattern) to show that the receiver is ready to be associated with a sensor (see part 2 of the following figure).

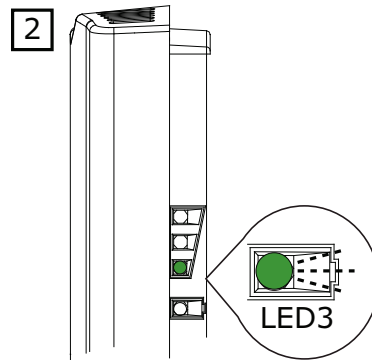
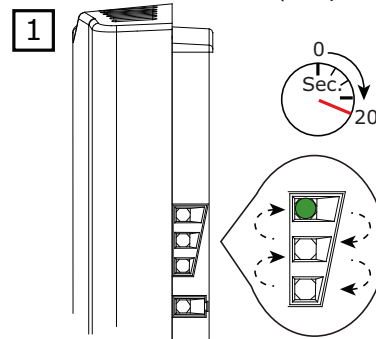

### Associating the Sensor to the Receiver

To associate the sensor to the receiver:

1. Remove the sensor cover by firmly pressing the thumb tab at the bottom of the cover and pulling the cover away from the back plate.
2. Verify that the sensor is set to the same address as the receiver it is to be associated with.
3. Power the sensor by removing the insulation strip from between the two batteries.

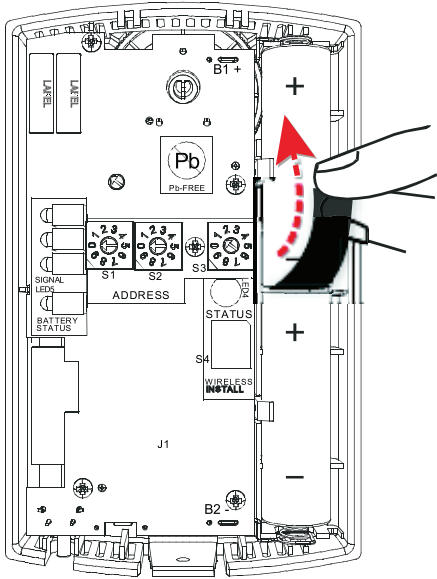

Association is automatically initiated between the sensor and the receiver. When LED3 on the receiver stops blinking, association has been established.

If the first association attempt is unsuccessful, the sensor automatically re-attempts association with the receiver every 10 minutes.

**Note:** An associated sensor that has lost communication with the receiver will transmit an association request every 50 minutes. You can manually initiate association (see “Manual Association,” p. 99).

### Testing Signal Strength and Battery Status

To verify that the association process was successful and that the batteries have adequate charge:

1. Firmly press and release the Test button on the bottom of the sensor (as illustrated below).
2. For model WZS, view LED1, LED2, and LED3 to determine the signal strength. View LED5 to determine the battery status (see the following figure for model WZS sensors).

**Note:** The LEDs will turn Off after 5 seconds to conserve battery strength.

For model WDS, determine the signal strength and battery status by viewing the symbols on the sensor display (see the following figure for model WDS sensors).

3. Record the results in your commissioning statement.

**Note:** For more information, see “Testing Signal Strength,” p. 97 and “Testing Battery Status,” p. 98.

Figure 50. Model WZS sensor

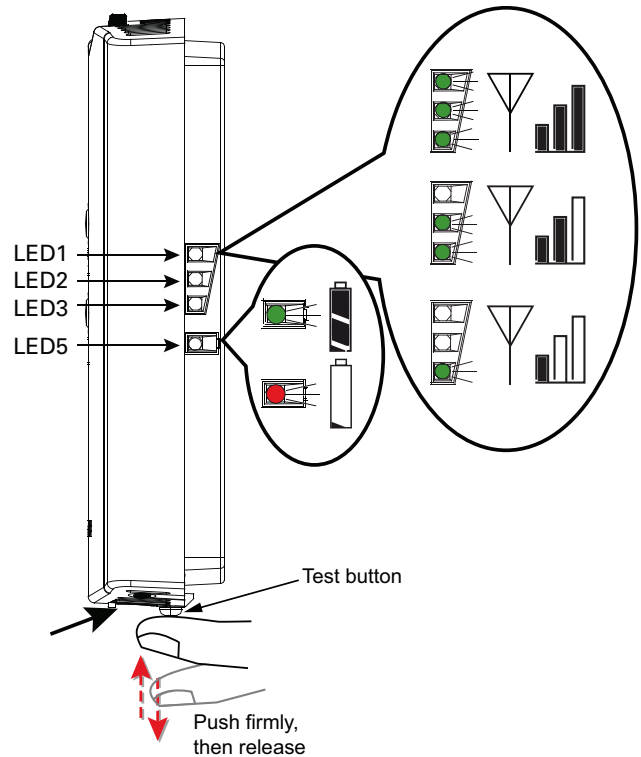
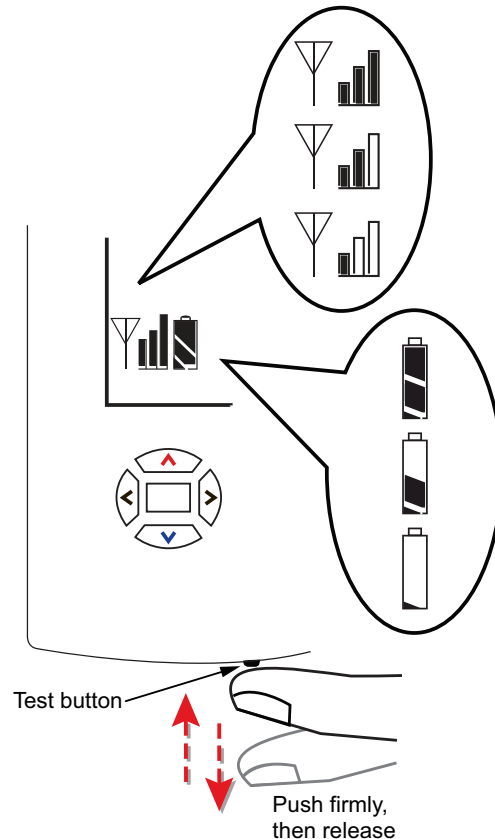

Figure 51. Model WDS sensor



## Sensor Operations

### Temporary Occupancy (Timed Override)

Temporary occupancy (timed override) is available on model WDS. Temporary occupancy is selected for after-business-hours adjustment of temperature setting, fan settings, or heat/cool settings, when the system has changed to unoccupied mode. System control will revert to unoccupied after a pre-determined time period.

**Note:** *Not all systems support the occupancy function.*

### Model WDS Sensor

To request and cancel temporary occupancy on a model WDS sensor, see “[Requesting Temporary Occupancy](#),” p. 58.

### End-of-Range Temperature Values

**Receiver:** The end-of-range temperature limits of the receiver for all models are 32°F to 122°F. The receiver cannot replicate temperature values outside this range. If the sensor transmits a temperature value to the receiver that is out of the receiver replication range, the receiver will freeze the output at the end-of-range values. This value will remain frozen until the transmitted temperature moves to between the end-of-range temperature limits.

**Sensor:** The end-of-range temperature setpoint limits for the model WDS sensor is 50°F to 89.6°F.

### Receiver Power-up Sequence

When power is applied to the receiver, one of the following sequences occurs. The sequence is dependent on the address setting and the association status of the receiver.

#### Address set to 000 and receiver is not associated with a sensor

- LED5 is constantly On, indicating power is applied and the receiver is functional.
- All models: Zone temperature and cooling setpoint default to 72.5°F.
  - WDS only: The heating setpoint defaults to 70.5°F and the fan/system output will be 2230 Ω. (see “[Failure and Default Modes](#),” p. 101).
- Status LED3 will display a 2-blink pattern diagnostic.

#### Address set from 001 to 999 and receiver is not associated with a sensor

- LED5 is constantly On, indicating power is applied and the receiver is functional.
- All models: Zone temperature and cooling setpoint default to 72.5°F.
  - WDS only: The heating setpoint defaults to 70.5°F and the fan/system output will be 2230 Ω. (see “[Failure and Default Modes](#),” p. 101).
- The receiver conducts an energy scan for 20 seconds to determine the clearest channel on which to operate.

- LED3 flashes On every 2 seconds when it is ready to accept a sensor association request. When an association request is made by a sensor, the receiver instructs the sensor on which power level to operate. Then the receiver and sensor begin operation at the appropriate channel and power level (see “[Observing the Receiver for Readiness to Associate](#),” p. 51).

#### Address set from 001 to 999 (and not changed since most recent power-up) and receiver is associated with a sensor

- LED5 is constantly On, indicating power is applied and the receiver is functional.
- Zone temperature and setpoint default to 72.5°F. WDS only: Heating setpoint defaults to 70.5°F, Fan = Auto, System = Off.
- The receiver waits for a broadcast transmission from its associated sensor. When a transmission is received, the receiver positions its zone temperature and setpoint outputs appropriately.
- If the receiver does not receive a communicated signal from its associated sensor within 35 minutes, zone temperature and setpoint outputs fail, generating a unit controller alarm (see “[Failure and Default Modes](#),” p. 101).

**Note:** *Once a receiver communicates to a WDS sensor, the receiver disables (opens) its zone setpoint output indefinitely.*

### Transmission Variables

Sensor transition time variables are as follows:

- The maximum time between sensor temperature transmissions is 15 minutes.
- The minimum time between sensor temperature transmissions is 30 seconds.
- The minimum time for transmitting temperature setpoint changes is 10 seconds.

**Note:** *If a sensor transmits a message to the receiver and the receiver does not reply, the sensor will retransmit the message to the receiver every 30 seconds until communication to the receiver is re-established.*

Sensor temperature time variables are as follows:

- The minimum change in zone temperature required to force a sensor transmission is:
  - 0.2°F when the temperature range is between 60°F and 80°F.
  - 0.5°F when the temperature range is between 32°F and 60°F or between 80°F and 122°F.
- The minimum change in temperature setpoint required to force a sensor transmission is:
  - 0.1°C for a model WDS sensor.

## Wireless Sensor Specifications

The following table presents specifications for all models of the wireless sensor sets.

**Table 15. Wireless sensor specifications**

| Component                            | Type   |
|--------------------------------------|--|
| Sensor operating temperature         | 32°F to 122°F  |
| Receiver operating temperature       | -40°F to 158°F   |
| Storage temperature                  | -40°F to 185°F   |
| Storage and operating humidity range | 5% to 95%, non-condensing  |
| Accuracy                             | 0.5°F over a range of 55°F to 85°F.  |
| Resolution                           | 0.125°F over a range of 60°F to 80°F<br>0.25°F when outside this range                                     |
| Setpoint functional range (WDS only) | 50°F to 89.6°F   |
| Receiver voltage                     | 24 V nominal ac/dc ±10%  |
| Receiver power consumption           | <1 VA  |
| Housing                              | Polycarbonate/ABS blend, UV protected, UL 94-5VA flammability rating, suitable for application in a plenum |
| Mounting                             | 3.24 in (8.26 cm) for 2 mounting screws (supplied)   |
| Sensor battery                       | (2) AA, 1.5 V, 2800 mAh, lithium, 5-year life, UL listed   |
| Range <sup>(a)</sup>                 | Open range: 2,500 ft (762 m)<br>(packet error rate = 2%)<br>Usable: 200 ft (61 m)<br>Typical: 75 ft (23 m) |
| Output power                         | 100 mW   |
| Radio frequency                      | 2.4 GHz (IEEE Std 802.15.4-2003 compliant)<br>(2405 to 2480 MHz, 5 MHz spacing)                            |
| Radio channels                       | 16   |
| Address range                        | 000 to 999   |
| Minimum time between transmissions   | 30 seconds   |
| Maximum time between transmissions   | 15 minutes   |

<sup>(a)</sup> Range values are estimated transmission distances for satisfactory operation. Actual distance is job specific and must be determined during site evaluation.

## Agency Compliance

The European Union (EU) Declaration of Conformity is available from your local Trane® office.

## Configuring the Wireless Display Sensor (Model WDS only)

**Note:** Sensors shipped with the fan-coil are pre-configured for three speeds.

The configuration of the sensor determines which system features can be accessed and changes can be made by the tenant (for example, changes to cooling/heating mode, setpoint, or fan speed). Verify system and associated unit features before configuring the sensor.

The building owner or operator may choose to limit tenant access to certain features. This can be done through configuration. Or, if a sensor is configured to match all control capabilities of the building automation system, the locking feature can be used to restrict the tenant from making changes.

### Configuration Procedure

To configure settings on the model WDS sensor, follow this procedure in the order presented.

1. Press the configuration button for 3 seconds.

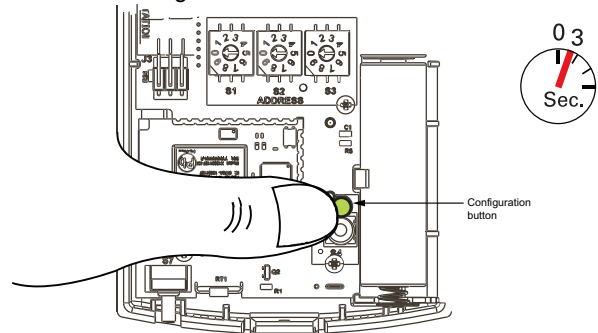

The display will change to configuration mode. When the sensor is in configuration mode, a wrench symbol appears on the display and the menus are separated by lines, as illustrated below.

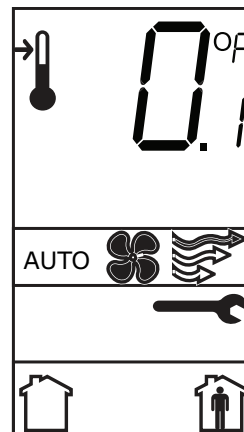

2. Press the center button on the keypad to begin the configuration process.

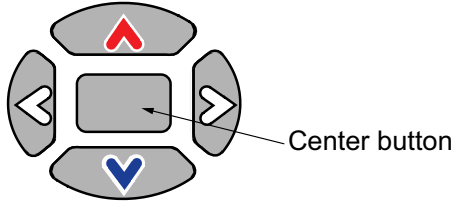

3. Configure the sensor options in the order shown in the table.

- Press or to scroll to the next selection (as illustrated).
- Press or to move to the next menu (as illustrated).

| Setting  | Configuration Options |
|--|-----------------------|
| <b>Temperature</b> <ul style="list-style-type: none"> <li>• Choose Fahrenheit or Celsius</li> <li>• Choose the degree resolution (whole degrees, half degrees, or tenths of degrees).</li> </ul> |                       |
| <b>Setpoint</b>  |                       |
| <b>System</b>  |                       |
| <b>Fan</b><br><i>Note: Not all fan options are available for all systems.</i>  |                       |
| <b>Occupancy (timed override)</b>  |                       |

4. Review the display to ensure that you have selected the correct configuration.

5. To return the display to operating mode, press the configuration button (see [Step 1.](#)).

**Note:** The sensor will revert to operating mode if no buttons are pressed for 10 minutes.

## Displaying Setpoint or Temperature

You can configure the sensor to display either the temperature (default) or setpoint. To select either option:

1. Verify that the sensor is in operating mode and at the home screen.
2. Press the up and down arrows for 3 seconds. The arrow indicates setpoint display, as shown in the figure.

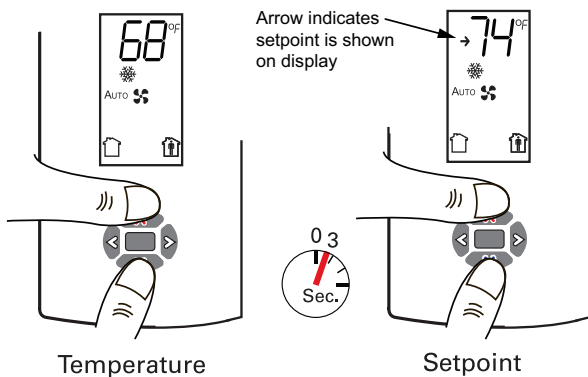

3. Press the left and right arrows for 4 seconds.

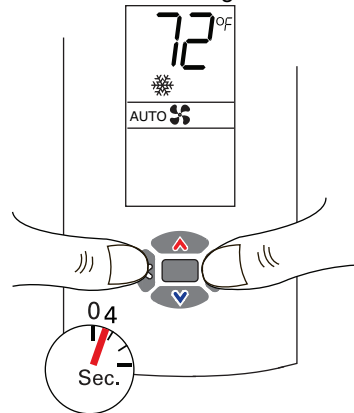

**Note:** If you try to access a feature that is locked, the locked symbol will appear on the display. If you press a keypad button to try change a locked setting, the locked symbol will flash.

## Locking or Unlocking Settings

You can lock or unlock the setpoint, system, or fan setting to prevent changes.

To lock or unlock a setting:

1. Verify that the sensor is in operating mode and at the home screen.
2. Choose a setting to lock or unlock:
  - Select the setpoint by pressing the up or down arrow.



Setpoint

- From the system menu press the down arrow to select the fan menu. Use the left or right arrow to choose the setting.



Fan menu



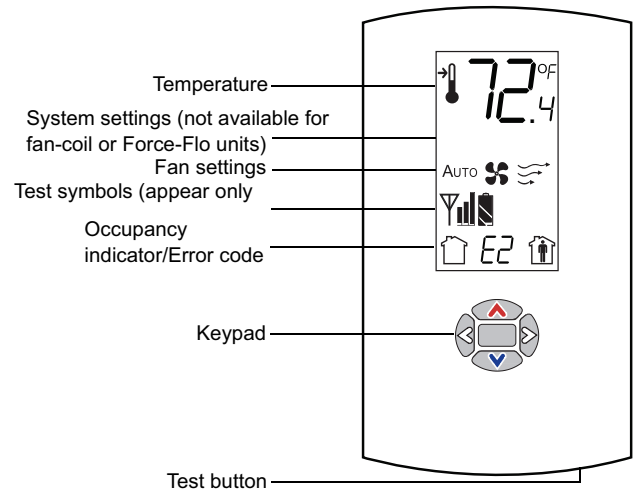

## WDS Operating Mode

This section describes how to operate the Trane wireless sensor, model WDS. [Figure 52, p. 56](#) shows an example of a model WDS that has been configured and is in operating mode.

**Figure 52. Wireless sensor (model WDS) in operating mode**













### Changing Room Temperature











|   |   |  |
|---|---|--|
|  | <p>This symbol shows the current room temperature, or your setpoint selection while you are making an adjustment.</p> <p>When you select a setpoint, this symbol appears.</p> | <p>1. To increase the room temperature, press . To decrease the room temperature, press .</p> <p>2. To confirm, press  or wait 5 seconds. The display will return to the home screen.</p> |
|---|---|--|

### Changing Heating and Cooling Room Temperature Settings

(applies to some systems)

|   |  |   |
|---|--|---|
|  | <p>Some systems allow you to select both heating and cooling room temperature settings. If your system has this option, this symbol appears when you adjust the temperature setting.</p> | <p>1. Press  or  to select the heating/cooling setting.</p> <p>2. If in cooling mode, press  to change to heating mode. If in heating mode, press  to change to cooling mode.</p> |
|  | <p>When you adjust the cooling setting, the top arrow and snowflake flash.</p>   | <p>3. Press  or  to select the heating/cooling setting.</p>   |
|  | <p>When you adjust the heating setting, the bottom arrow and flame flash.</p>  | <p>4. To confirm, press  or wait 5 seconds. The home screen will appear.</p>   |

### Changing the Fan Setting

|  |  |  |
|--|--|--|
|   | <p>Indicates that the fan will operate as needed to reach the selected temperature.</p>  | <p>1. From the home screen, activate the fan setting menu by pressing  and then .</p> <p>2. Press  or  to choose the desired fan setting.</p> <p>3. When the symbol for the desired setting appears, confirm your choice by</p> <ul style="list-style-type: none"> <li>• Pressing  (the home screen will appear), or</li> <li>• Pressing  or  (the next menu will appear), or</li> <li>• Waiting five seconds.</li> </ul> |
|  | <p>Indicates that the fan setting is On. The number of arrows indicates fan speed (3: high, 2: medium, 1: low). The example shown indicates a fan on high speed. Not all systems offer all three speeds.</p> |  |
|  | <p>Indicates that the fan setting is Off.</p>  |  |

### Requesting Temporary Occupancy

|  |                             |  |
|--|-----------------------------|--|
|  | Select to request occupancy | <ul style="list-style-type: none"> <li>If you need heating or cooling after normal business hours, you can request temporary occupancy by pressing  and holding it for 2 seconds. The occupied symbol remains on the screen and the unoccupied symbol disappears. After 30 seconds, the unoccupied symbol will re-appear.</li> </ul> |
|  | Select to cancel occupancy  | <ul style="list-style-type: none"> <li>To cancel temporary occupancy, press  and hold for 2 seconds. The unoccupied symbol will remain on the screen and the occupied symbol will disappear. After 30 seconds, the occupied symbol will re-appear.</li> </ul>  |

### Error Codes

|  |                         |  |
|--|-------------------------|--|
|  | Indicates an error code | If an error code (E0–E7) is displayed, technical assistance may be required. |
|--|-------------------------|--|

### Lock Symbol

|  |                                    |  |
|--|------------------------------------|--|
|  | Indicates that a setting is locked | The lock symbol appears if you try to adjust a setting that cannot be changed. |
|--|------------------------------------|--|

### Testing Signal Strength

|                                     |  |                                |
|-------------------------------------|--|--------------------------------|
| Indicates excellent signal strength | Indicates satisfactory signal strength | Indicates poor signal strength |
|-------------------------------------|--|--------------------------------|

Press the Test button to display the signal strength symbols.

### Testing Battery Status

|                               |                                     |  |
|-------------------------------|-------------------------------------|--|
| Indicates full battery power. | Indicates 50% of battery life left. | Indicates 25% of battery life left. Replace batteries. Flashing symbol indicates that approximately 14 days of operation remain. |
|-------------------------------|-------------------------------------|--|

Press the Test button to display the battery status symbols. Use only UL-listed non-rechargeable 1.5 V lithium AA batteries (Trane p/n X13770035010 or equivalent).

### Time Clock

#### Setting the Time Clock

The Time Clock must be programmed for the unit to operate. If not programmed, the unit may not run in the correct occupied/unoccupied state until timing instructions are received from the Time Clock.

**Note:** Power must be supplied to the unit for the time clock to be set.

The following procedure covers:

- Setting the time format
- Setting the current time and day
- Setting the program ON/OFF settings (events)
- Pre set program selections
- Deleting programs
- Daylight savings setting
- Overriding programs (manually)

Figure 53. Time clock

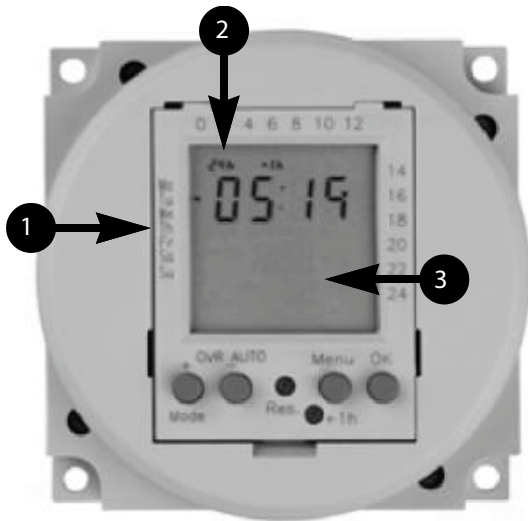

1. Time format display
2. Day display
3. LED display

The time clock (see Figure 53, p. 59) is located behind the access door of a Unit Ventilator.

### Reset the Time Clock

To clear any programs that may exist from the factory, press the reset button (**Res.**).

**Note:** The time clock uses Standard Time. If you are programming during Daylight Savings Time, one hour should be subtracted from times needed (see "Daylight Savings Time," p. 60).

For example, if the Daylight Savings Time is 2:30, the time setting for the clock should be 1:30.

### Set the Time Format, Time, and Day

(Program to 24 hr or am/pm format.)

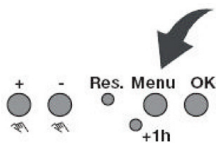

1. Press the **Menu** button until the display screen is blank (time not showing) and **24h** or **am/pm** is blinking in the upper left corner of the screen.
2. Use the **+** and/or **-** buttons to select the desired setting and then press **OK**.
3. The hour display begins to blink — use the **+** and/or **-** buttons to select the desired setting and then press **OK**.
4. The minute display begins to blink — use **+/-** to select the desired setting and press **OK**.
5. The day display (on the left side of the display screen) begins to blink — use **+/-** to select the desired setting and press **OK**.

### Set the Program

**Note:** The Time Clock should be used to program the unit for the UNOCCUPIED mode — the periods of time when the unit will not be in operation. The mode you are programming is shown on the LED display:

: The Timer is in operation (ON). The unit is in UNOCCUPIED mode.

: The Timer is not in operation (OFF). The unit is in OCCUPIED mode.

**Note:** Odd number programs activate the timer ON function (the unit is in UNOCCUPIED mode) and even number programs activate the timer OFF function (the unit is in OCCUPIED mode).

### Set the Switching ON Time

Figure 54. Setting the switching ON time



1. Press **OK** until **prog 01** is visible on the LED display (see Figure 54, p. 59).

**Note:** When **prog 01** is visible, **01** should be blinking and the ON symbol, , should be displayed in the LED window. Press **OK** again.

2. The hour display begins to blink — use the **+** and/or **-** buttons to select the desired setting and then press **OK**.
3. The minute display begins to blink — use **+/-** to select the desired setting and press **OK**.
4. The day display (on the left side of the display screen) begins to blink—use **+/-** to select the desired setting and press **OK**.

**Note:** After you set the switching ON time, the prog number should increase by one (for example, from **prog 01** to **prog 02**). The number should be blinking and the OFF symbol, , should be displayed in the LED window. Set the switching OFF time.

### Set the Switching OFF Time

1. The hour display begins to blink—use the **+** and/or **-** buttons to select the desired setting and then press **OK**.
2. The minute display begins to blink—use **+/-** to select the desired setting and press **OK**.
3. The day display (on the left side of the display screen) begins to blink—use **+/-** to select the desired setting and press **OK**.

**Note:** Repeat the steps for setting the switching ON/OFF times for each additional programming needed. You can set a maximum of 20 times: 10 switching ON times, and 10 switching OFF times.

## Preset Program Selections

When selecting daily programming, preset selections can be used.

**Figure 55. Preset program selection options**

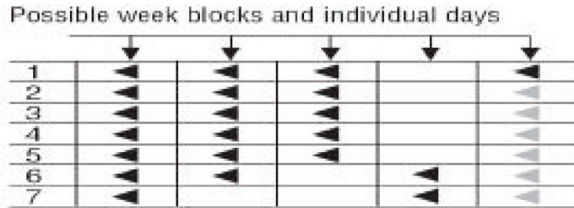

## Deleting Programs

1. Press the **Menu** button and then press **OK** until the ON hour time display of the program you want to delete is blinking.
2. Use the **+/-** to select **-** and then press **OK**.

**Important:** Switching programs **must** be deleted in ON-OFF pairs. When you delete a single ON instruction, you must also delete the corresponding OFF instruction.

## Daylight Savings Time

**Note:** Use **+1h** button to make the change to and from Daylight Savings Time.

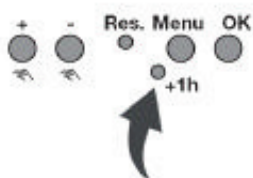

Press the **+1h** button to add 1 hour to the current time. Press the **+1h** button again to subtract 1 hour from the current time.

**Figure 56. Daylight savings time**



## Override Program (Manual)

To override the program, press the **OVR (+)** button.

Toggle between the unoccupied  and occupied  states by pressing the **OVR (+)** button.

**Note:** When you override the program, the override remains in effect until the next programming event or until you press **OVR** again.



# Installation – Electrical

Table 16. Motor quantity and horsepower

| Unit size |         |         |         |
|-----------|---------|---------|---------|
| 0750      | 1000    | 1250    | 1500    |
| 1 - 1/4   | 1 - 1/4 | 2 - 1/4 | 2 - 1/4 |

## ⚠ WARNING

### Proper Field Wiring and Grounding Required!

Failure to follow code could result in death or serious injury.

All field wiring **MUST** be performed by qualified personnel. Improperly installed and grounded field wiring poses **FIRE** and **ELECTROCUTION** hazards. To avoid these hazards, you **MUST** follow requirements for field wiring installation and grounding as described in NEC and your local/state/national electrical codes.

## ⚠ WARNING

### Electrical Shock Hazard!

Failure to follow instructions below could result in death or serious injury.

System contains oversized grounding terminal. All field wiring **MUST** be performed by qualified personnel. Improperly installed and grounded field wiring poses **FIRE** and **ELECTROCUTION** hazards. To avoid these hazards, you **MUST** follow requirements for field wiring installation and grounding as described in NEC and your local/state/national electrical codes.

## ⚠ WARNING

### Hazardous Voltage!

Failure to disconnect power before servicing could result in death or serious injury.

Disconnect all electric power, including remote disconnects before servicing. Follow proper lockout/tagout procedures to ensure the power can not be inadvertently energized. Verify that no power is present with a voltmeter.

## NOTICE

### Equipment Damage!

Failure to follow instructions below could result in premature motor failures or equipment damage. Refer to the diagram provided on the equipment for specific information. Do not remove or alter the wiring of the time delay relay (DL). Wiring diagrams provided in this manual are for **REFERENCE ONLY**. Actual wiring for particular options/units could vary.

## ⚠ WARNING

### Fire Hazard!

Failure to follow instructions below could cause a fire, which could result in death or serious injury, and property damage.

- **DO NOT** jumper factory wiring! Miswiring of safety circuits could cause a fire.
- Refer to the wiring diagram shipped with the unit for all wiring connections.
- When replacement wiring is required, use only material with temperature rating of at least 221° F (105°C).

**Control Power:** Unit ventilator controls and control wiring can be factory mounted or field installed.

Wiring diagrams illustrate the standard unit motors with one or more speed controls. Terminal wiring is provided by Trane and the actual components used for a particular installation may differ. Control and line diagrams for the exact control system used are provided with each unit.

## NOTICE

### Use Copper Conductors Only!

Failure to use copper conductors could result in equipment damage as the equipment was not designed or qualified to accept other types of conductors.

## ⚠ WARNING

### Electrical Shock Hazard!

Failure to follow instructions below could result in death or serious injury.

Verify disconnect ability incorporated in fixed wiring in accordance with the requirements in NEC and local/state/national electric codes.

## Electrical Wiring

**Unit Wiring Diagrams:** Specific unit wiring diagrams, based on unit options ordered, are provided inside each unit and can be easily removed for reference. Use these diagrams for connections or trouble analysis. Wiring diagrams are attached on the inside of the front panel of the unit.

**Supply Power Wiring:** Refer to the unit nameplate to obtain the minimum circuit ampacity (MCA) and maximum fuse size (MFS) or maximum circuit breaker (MCB) to properly size field supply wiring and fuses or circuit breakers. Refer to the unit operating voltage listed on the unit wiring schematic, submittal, or nameplate. Reference the wiring schematic for specific wiring connections.



## Installation – Electrical

**Note:** All field wiring should conform to NEC and all applicable state and local code requirements. The control panel box is always on the end opposite the piping connections. Access the control box by removing the two screws that secure the front cover. This will allow the panel to be removed, to provide access to the electrical components.

If the unit does not have a disconnect switch, the power leads and capped ground wire are inside the control panel. If the unit has a disconnect switch, the power leads are wired to the junction box switch on the control panel. Pull the capped ground wire into the junction box.

**Electrical Grounding Restrictions:** All sensor and input circuits are normally at or near ground (common) potential. When wiring sensors and other input devices to the Tracer® controller, avoid creating ground loops with grounded conductors external to the unit control circuit. Ground loops can affect the measurement accuracy of the controller.

All input/output circuits (except isolated relay contacts and optically isolated inputs) assume a grounded source, either a ground wire at the supply transformer to control panel chassis, or an installer supplied ground.

**Wall-Mounted Control Interconnection Wiring:** The installer must provide interconnection wiring to connect wall-mounted devices such as a fan mode switch or zone sensor module. Refer to the unit wiring schematic for specific wiring details and point-to-point wiring connections. Dashed lines indicate field wiring on the unit wiring schematics. All interconnection wiring must conform to NEC Class 2 wiring requirements and any state and local requirements. Refer to the following table for the wire size range and maximum wiring distance for each device.

**Table 17. Maximum wiring distances for low voltage controls (ft.)**

| Device                     | Wire Size | Range |
|----------------------------|-----------|-------|
| Fan Control Switch         | 14–22 AWG | 500   |
| Zone Sensor/<br>Thermostat | 16–22 AWG | 200   |

**Important:** Do not bundle or run interconnection wiring in parallel with or in the same conduit with any high-voltage wires (110 V or greater). Exposure of interconnection wiring to high voltage wiring, inductive loads, or RF transmitters may cause radio frequency interference (RFI). In addition, improper separation may cause electrical noise problems. Therefore, use shielded wire (Belden 83559/83562 or equivalent) in applications that require a high degree of noise immunity. Connect the shield to the chassis ground and tape at the other end.

**Note:** Do not connect any sensor or input circuit to an external ground connection.

**Supply Power:** Power supply wiring is to be connected to terminals 1 and 2 at the junction box in the left end pocket, below the discharge air grille.

### NOTICE

#### Use Copper Conductors Only!

Failure to use copper conductors could result in equipment damage as the equipment was not designed or qualified to accept other types of conductors.

## Electric Heat

### ⚠ WARNING

#### Hazardous Voltage!

Failure to disconnect power before servicing could result in death or serious injury.

Disconnect all electric power, including remote disconnects before servicing. Follow proper lockout/tagout procedures to ensure the power can not be inadvertently energized. Verify that no power is present with a voltmeter.

**Supply Power:** Supply power wiring is to be connected to the following line terminals in the right-hand end pocket:

- 208V or 240V, 3-phase, 3-wire system: L1, L2, and L3.
- 480V, 3-phase, 4-wire system: L1, L2, L3, and N (neutral)

### NOTICE

#### Equipment Damage!

Failure to follow instructions below could result in equipment damage.

Provide a 4-wire system with separate ground. Do not use 480V/3-wire system, as it is not compatible with this equipment.

**Note:** The supply neutral wire must be connected to the neutral terminal block.

Operational controls and an electric heating safety device are factory mounted. The safety device is a high temp cutout which de-energizes electric heating elements through the K1 safety contactor.

## DX Split System

A typical unit ventilator with DX coil includes an outside air thermostat, a frost prevention thermostat, and a 24 V transformer for condensing unit control.

Wire sizing is the same as given for the thermostat wiring in the condensing unit installation instructions, or may be obtained from the nameplate. The condensing unit must be controlled by the same room thermostat that also controls the unit ventilator.

## Split System Start-Up

After all piping and wiring has been completed, follow the instructions provided with the condensing unit for control testing and system start-up. If sweat type field-piped systems are being used, then pressure testing, evacuation, and refrigerant charging will be required.

Two bulbs will also be shipped with a split system unit:

- Froststat® bulb
- TXV bulb

Both components are to be field installed using the installation kit shipped with the unit. For complete installation instructions and locations, refer to the tag attached to the coil.



# ECM Overview and Setup

## Overview

This section addresses integrating the new Trane electronically commutated motor (ECM) and VelociTach™ motor control board. This exciting new series delivers outstanding comfort, safety, and performance with greatly reduced energy consumption compared to traditional units with induction AC motors.

The new series of units will provide a long service life with proper installation and operation. The new system provides a high degree of flexibility and configurability, but the simplicity of customized factory configuration appropriate to most installations.

Very little intervention is needed by service and installation personnel in most applications; however, installers must read through the entire document before beginning installation of the new equipment.

This literature focuses on unit motors and controls, including three new circuit modules developed specifically for this series.

Figure 57.

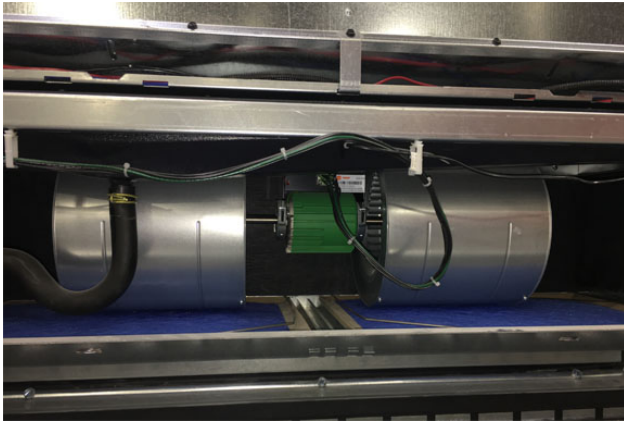

The primary components that enable the technology on your product:

- Trane electronically commutated motor (ECM)
- VelociTach™ motor control board
- CSTI adapter board (CSTI control only)

The motors and modules are combined as systems, and cannot work without each other.

## Electronically Commutated Motor (ECM)

Figure 58. Trane ECM



- The ECM has integrated electronics, overload protection and short circuit protection. The motor contains no user-serviceable components inside.

### NOTICE

#### Equipment Damage!

Failure to follow these instructions could result in equipment damage.

The motor harness attached to the single plug to which the motor mates contains the 115V motor voltage jumper. The motor harness should always be present for 115V units and should not be modified or substituted.

- The motor mates to the unit electrically via a single plug that contains both the operating voltage and the control signals that are needed for correct operation.

## VelociTach™ Motor Control Board

The VelociTach™ motor control board controls and reports the performance of up to two Trane brushless DC (BLDC) motors.

Figure 59. VelociTach™ motor control board

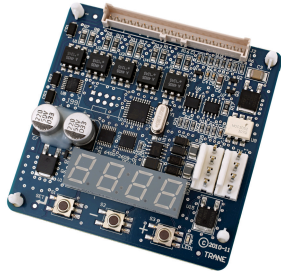

The motor control board also:

- Coordinates the operation of the fan in response to electric heat behavior and electric behavior in response to hydronic heat behavior.
- Incorporates a user interface that allows adjustment of certain unit parameters and provides constant feedback on motor operation.
- Integrates service and troubleshooting tools.

Table 18. Screen representation of alphabetical characters

| A | B | C | D | E | F | G | H | I | J | K | L | M | N | O | P | Q | R | S | T | U | V | W | X | Y | Z |   |
|---|---|---|---|---|---|---|---|---|---|---|---|---|---|---|---|---|---|---|---|---|---|---|---|---|---|---|
| A | b | c | d | E | F | g | H | i | J | K | L | ñ | n | o | P | q | r | S | t | U | u | v | w | x | y | z |

Table 19. Screen representation of numeric characters

| 1 | 2 | 3 | 4 | 5 | 6 | 7 | 8 | 9 | 0 |
|---|---|---|---|---|---|---|---|---|---|
| 1 | 2 | 3 | 4 | 5 | 6 | 7 | 8 | 9 | 0 |

## Installation and Initial Setup

### ⚠ WARNING

#### Hazardous Voltage w/Capacitors!

Failure to disconnect power and discharge capacitors before servicing could result in death or serious injury.

Disconnect all electric power, including remote disconnects and discharge all motor start/run capacitors before servicing. Follow proper lockout/tagout procedures to ensure the power cannot be inadvertently energized. Verify with a CAT III or IV voltmeter rated per NFPA 70E that all capacitors have discharged.

- Integrates a versatile configurable auxiliary temperature sensor.
- Incorporates various safety and lockout features, such as maintaining proper fan speeds if electric heat is called for.

## Status Display

Figure 60. Status display

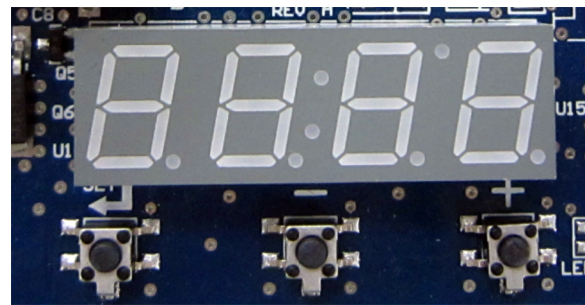

The motor control board contains a four-digit, seven-segment display that is used to present information in a format close to real-world language, while having a small-form factor. Most characters are immediately recognizable; however, please consult Table 18, p. 65 and Table 19, p. 65 for the graphical representation of each alphanumeric character.

### ⚠ WARNING

#### Hazardous Service Procedures!

Failure to follow all precautions in this manual and on the tags, stickers, and labels could result in death or serious injury.

Technicians, in order to protect themselves from potential electrical, mechanical, and chemical hazards, MUST follow precautions in this manual and on the tags, stickers, and labels, as well as the following instructions: Unless specified otherwise, disconnect all electrical power including remote disconnect and discharge all energy storing devices such as capacitors before servicing. Follow proper lockout/tagout procedures to ensure the power can not be inadvertently energized. When necessary to work with live electrical components, have a qualified licensed electrician or other individual who has been trained in handling live electrical components perform these tasks.



## ECM Overview and Setup

### Safety Requirements

Follow all recommendations below. Failure to do so could result in death or serious injury.

- The ECM motors contain capacitors which store residual energy. Please keep clear of the fan wheels for 5 minutes after the power has been removed from the system, as a power request with the motor powered off, could result in a very short period of actuation.
- All settings take effect immediately, including fan start-up and enabling of electric heat. Caution should be taken to stay clear of hazardous voltages, moving parts and electric heat elements while making adjustments to the VelociTach™ motor control board. If it is not practical to stay clear of these areas during adjustment of the motor control board, please contact Trane Global Parts for configuration kit that allows easy powering of the motor control board outside of the unit with a 9 V battery.
- Changes to switch settings on the CSTI adapter board take effect immediately. Changes should be made to the CSTI configuration switches with the power off.
- Initial hookups to the CSTI and Standard Adapter board, including low voltage interconnections, must be made with the power off.
- Do not make connections to the motors or the adapter boards while power is ON. Do not remove connections to the motor or the adapter boards while the power is ON.
- Do not free spin the fan wheels with your hands while the unit is powered on. The system is constantly scanning and responding to the operational status of the motors.

### Setup

**Note:** Normally, Trane ECMs are configured for soft ramps and transitions between speeds. However, to aid in commissioning of the unit, for approximately 10 to 15 minutes, the ramps will be shortened to quickly observe proper unit behavior and response to speeds.

For new installations, all boards and motors are pre-installed and pre-configured according to the unit configuration, indicated by its model number.

Under normal and intended operation, the only required intervention specific to the new ECM units is the wiring of:

- Wall-mounted low-voltage fan speed switch inputs to the adapter boards' terminal strips and 24 Vac tap to field-installed fan speed switch.
- Field-supplied controllers/thermostats to the adapter boards' terminal strips and 24 Vac power tap to field supplied controller/thermostat.
- Adjustment and calibration of the variable speed inputs (VSP/0 to 10V) on the system.
- Adjustment, calibration or disabling of the optional auto-changeover function on CSTI units.

Otherwise, proceed with the mechanical, electrical and controls installations as defined in other sections of this manual, following all warnings and cautions.

After installation, turn power on.

**Note:** Specifications subject to change without notice. Consult the unit submittals and unit schematics before determining hookup requirements. Terminal block positions, polarities and assignments are determined for specific unit configurations only. Signal assignments are indicated, for reference only.

Both adapter boards come equipped with integrated terminal blocks to hook up to the field supplied/mounted fan speed switches and external controls. Connections should be made to the screw terminals with wires between 16 AWG and 24 AWG, with a ~4 to 5 mm wire strip length. The terminal blocks have 5 mm spacing, and are equipped with 3 mm screws. The field-supplied wires should have an insulation rating of 600V.

### VelociTach™ Motor Control Board

#### ⚠ WARNING

##### Safety Alert!

Failure to follow instructions below could result in death or serious injury.

All settings take effect immediately, including fan start and electric heat. Avoid hazardous voltage sources, moving parts, and electric heat elements when adjusting the motor control board. If avoiding these areas is not practical during motor control board adjustment, contact Trane Global Parts for configuration kit to power control board outside the unit with a 9-volt battery.

#### ⚠ CAUTION

##### Burn Hazard!

Failure to follow this instruction could result in the unit overheating and becoming hot to the touch, which could result in minor or moderate injury, and/or equipment damage.

On electric heat units, certain parameter values are locked out to prevent overheating of the unit. These functions will appear to be saved; however, they will not be accepted if the Electric Heat Protection setting is "On". Do not change the Electric Heat Protection setting to "Off" and make changes to the protected settings unless you are programming an unconfigured service replacement board to match the unit settings on an ECM configuration label.

The motor control board functions and unit specific settings are summarized on the motor control board configuration label affixed to the back side of the control panel low voltage lid on every unit.

To check status, configuration, or to change settings on the motor control board with the power on the unit, remove the two screws at the top of the low voltage access lid and

open. The motor control board will be visible. See [Figure 61](#), p. 67.

**Figure 61. VelociTach™ motor control board**

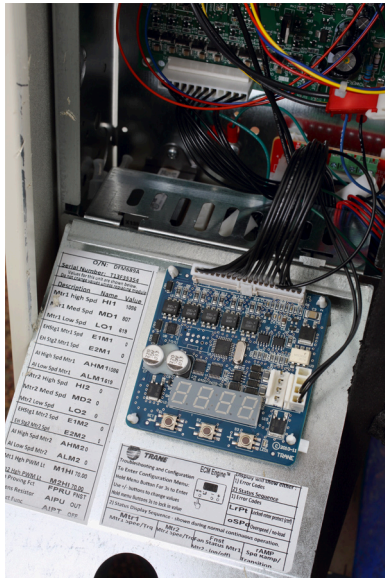

The motor control board features a nested menu integrated user interface (UI) that supports:

- Status display for instant touch-free confirmation of unit operation.
- Configuration parameter and value display and modification changes (using integrated menu/set buttons).
- Error code prioritized reporting.

**Note:** Characters on the VelociTach™ motor control board display appear in red, on a black background.

The display contains decimal positions as well that change position with each parameter, as appropriate. Under normal conditions (i.e., with no error code displayed), the status will loop the following message:

**Table 20. Operational status codes**

|  |                                      |   |
|--|--------------------------------------|---|
| <b>RPM ModeRUNNING/ FAN STATUS CONTINUOUS LOOP</b><br>Displayed when:<br>1. No error codes are present.<br>2. Motor has completed ramping. | $\dot{r}i\dot{t}r\ 1$<br>0000 → 2000 | Indicates the current rpm of Motor 1 in the system. "0" rpm here indicate that no fan speed has been requested.   |
|  | $\dot{r}i\dot{t}r\ 2$<br>0000 → 2000 | Indicates the current rpm of Motor 2 in the system. "0" rpm here indicate a fan off condition OR a fan "missing" condition.   |
|  | F5t 1<br>yE5 / n0                    | Indicates the status being calculated or Fan Motor 1. If "off," this indicates that either:<br>1. No fan speed is being requested or<br>2. The fan performance is failing to meet the request; refer to "ECM Motors," p. 108 for additional troubleshooting information.<br>If "on," this indicates that the fan is performing correctly and will be used to report fan status correctly, depending on FPRu mode.   |
|  | F5t 2<br>yE5 / n0                    | Indicates the status being calculated or Fan Motor 2. If "off," this indicates that either:<br>1. No fan speed is being requested or<br>2. The fan performance is failing to meet the request; refer to "ECM Motors," p. 108 for additional troubleshooting information.<br>3. If the target speed for Motor 2 is "0," this is used to indicate a missing motor.<br>If "on," this indicates that the fan is performing correctly and will be used to report fan status correctly, depending on FPRu mode. |
|  | EhEn<br>yE5 / n0                     | Indicates that the temperature sensing circuit has calculated a logical "on" based on the settings of the following parameters:<br>R 127 r R 12b r R 1PU  |

## User Interface

The VelociTach™ motor control board's on-board user interface is easy to use and supports:

- Verification/auditing of on-board parameter settings (read-only)
- Adjustment of the on-board settings (write)

The user interface has three input buttons (see [Figure 62](#), p. 68), from left to right:

- Menu/Set

- Decrement
- Increment

**Figure 62. User interface input buttons**

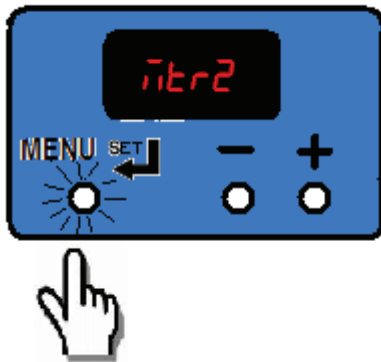

Each button has several different actuation levels depending on length of press, and what the UI is currently displaying.

**Table 21. Button actuation levels**

| Button                                   | Menu/Set |  |
|--|----------|--|
|  | Duration | Action   |
| Short Press in Status Display            | <1 sec   | None   |
| Short Press in Configuration Display     | —        | Toggles between parameter name and value without saving (abandons value if changed).   |
| Long Press/Hold in Status Display        | >3 sec   | Enters the configuration menu  |
| Long Press/Hold in Configuration Display | >3 sec   | If on a parameter name, toggles to the value. If on a parameter value, saves the value settings and returns to the parameter name as confirmation. |

| Button                                   | Increment |   |
|--|-----------|---|
|  | Duration  | Action  |
| Short Press in Status Display            | <1 sec    | None  |
| Short Press in Configuration Display     | <1 sec    | Scrolls through parameter names, or decreases value of parameter.                 |
| Long Press/Hold in Status Display        | >3 sec    | —   |
| Long Press/Hold in Configuration Display | >3 sec    | Faster scroll through parameter name, or faster decrease of values of parameters. |

| Button                                   | Decrement |   |
|--|-----------|---|
|  | Duration  | Action  |
| Short Press in Status Display            | <1 sec    | None  |
| Short Press in Configuration Display     | <1 sec    | Scrolls through parameter names, or increases value of parameter.                 |
| Long Press/Hold in Status Display        | >3 sec    | —   |
| Long Press/Hold in Configuration Display | —         | Faster scroll through parameter name, or faster increase of values of parameters. |

## Configuration Examples

**Example 1:** View the value of parameters without saving. Verify the low speed value for motor 1 is set to 800 rpm.

Start with the motor control board scrolling status display and proceed as follows:

**Figure 63. Verify low speed value**

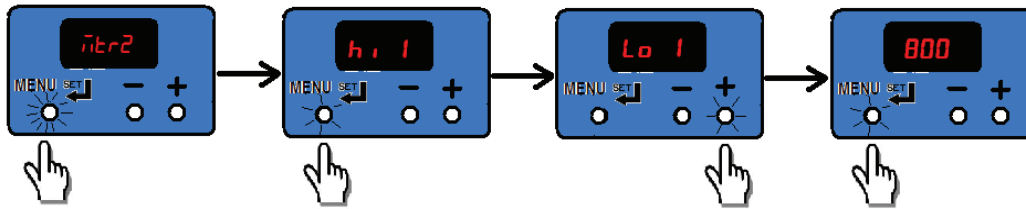

**Example 2:** Change the value of Low Speed to 820 rpm:

Continue from the previous example as shown below, using a long press to save the new desired value.

*If the display has timed out and returned to the status loop, repeat Example 1 to arrive back at this example's starting point.*

*If the display has timed out and returned to the status loop, repeat Example 1 and Example 2 to arrive back at this example's starting point.*

**Figure 65. Verify value of 820 rpm**

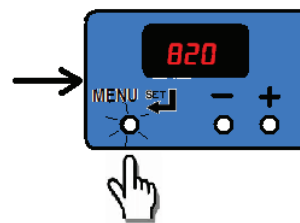

**Figure 64. Change value of low speed value**

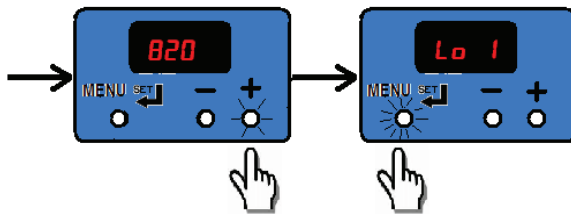

**Example 3:** Double-check the value of 820 rpm has been saved.

**Example 4:** Change the value of a protected value on an electric heat unit.

It appears the value has been changed, but after checking the value, the original value has been retained.

**Figure 66. Change value on electric heat unit**

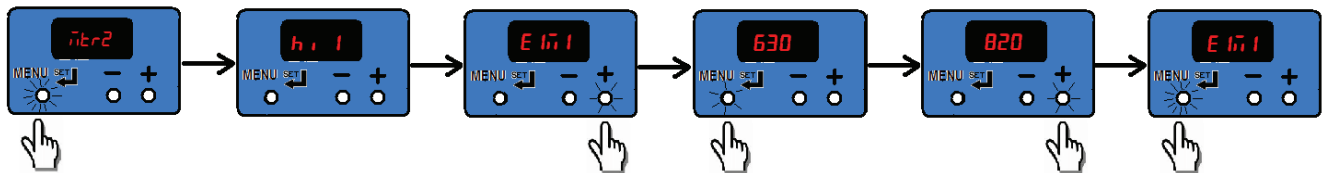

## Priority/Error Display

Under special conditions, the status display will interrupt briefly to prioritize display of events:

### Notes:

- During error displays, the user interface will be disabled, until the error is removed or resolved.
- If changes are made to parameters and saved, most settings take effect immediately. Any change to fan speeds will take effect and cause the configuration menu to exit immediately to begin tracking speeds via the on-board tachometer.
- If an error occurs while the configuration menu is in effect, all unsaved values will be discarded and the error codes will be displayed.



## ECM Overview and Setup

**Table 22. Error codes**

|                                      |   |  |
|--------------------------------------|---|--|
| Displayed during abnormal operation. | <p>Motor 1<br/>L0CH</p>                     | <p>Indicates a locked rotor condition of Motor 1. The motor will be locked out until the cause has been resolved, and the power cycled; refer to "ECM Motors," p. 108 for resolution details.</p> <p>Fan Status function, if being used, will report an inoperative motor. Electric heat and changeover heat will be shutdown.</p>   |
|                                      | <p>Motor 2<br/>L0CH</p>                     | <p>Indicates a locked rotor condition of Motor 2. The motor will be locked out until the cause has been resolved, and the power cycled; refer to "ECM Motors," p. 108 for resolution details.</p> <p>Motor 1 will continue to operate, but will not be monitored. Fan Status function, if being used, will report an inoperative motor. Electric heat and changeover heat will be shutdown.</p>  |
|                                      | <p>Motor 1<br/>05Pd</p>                     | <p>Indicates that Motor 1 has experienced a run-away or over speed condition, and has been shutdown. The unit will offer limited "limp-in" performance, and Motor 2 will continue to operate, but will not be monitored. Fan Status function, if being used, will report an inoperative motor.</p> <p>Refer to "ECM Motors," p. 108 to reset, the cause must be resolved and the power to the unit cycled. Electric heat and changeover heat will be shutdown.</p> |
|                                      | <p>Motor 2<br/>05Pd</p>                     | <p>Indicates that Motor 2 has experienced a run-away or over speed condition, and has been shutdown. The unit will offer limited "limp-in" performance, and Motor 1 will continue to operate, but will not be monitored. Fan Status function, if being used, will report an inoperative motor.</p> <p>Refer to "ECM Motors," p. 108 to reset, the cause must be resolved and the power to the unit cycled. Electric heat and changeover heat will be shutdown.</p> |
|                                      | <p>rAMP<br/>0000 → 2000<br/>2000 → 0000</p> | <p>Indicates the motor is transitioning between speeds, ramping up or down. The message "RAMP" is briefly displayed, followed by the target speed for "Motor 1" only. Once the target speed has been reached, the status display will resume operation.</p>  |
|                                      | <p>u123</p>                                 | <p>On power on, the version of software is briefly displayed, followed by the results of a POST (power on self test).</p>  |

**Note:** Fan coil units have only Motor 1 installed.

## Adjustments

After connections of power and hookup of customer installed controls/fan speed control and under normal operative conditions, the only adjustments needed to be made to the motor control board during commissioning of the unit are:

- Adjustment and calibration of the variable speed inputs (VSP/0 to 10V) on the system, where applicable.
- Adjustment, calibration or disabling of the optional auto-changeover function on CSTI units, where applicable.

In addition, the CSTI adapter board offers configurability that can be used in special cases to adjust the following operation of the unit:

- Courtesy cooling/main valve logic inversion relays for use with normally open valves
- Courtesy heating/auxiliary valve logic inversion relays for use with normally open valves
- Changeover function for use with changeover coils (in conjunction with the motor control board)

The switches are factory-set based on the model number configuration as ordered; however, the information is provided below to aid in the understanding of the operation of the system.

## Adjusting Variable Speed Inputs

### **⚠ WARNING**

#### **Hazardous Voltage w/Capacitors!**

**Failure to disconnect power and discharge capacitors before servicing could result in death or serious injury.**

**Disconnect all electric power, including remote disconnects and discharge all motor start/run capacitors before servicing. Follow proper lockout/tagout procedures to ensure the power cannot be inadvertently energized. Verify with a CAT III or IV voltmeter rated per NFPA 70E that all capacitors have discharged.**

### **⚠ WARNING**

#### **Safety Alert!**

**Failure to follow instructions below could result in death or serious injury.**

**All settings take effect immediately, including fan start and electric heat. Avoid hazardous voltage sources, moving parts, and electric heat elements when adjusting the motor control board. If avoiding these areas is not practical during motor control board adjustment, contact Trane Global Parts for configuration kit to power control board outside the unit with a 9-volt battery.**

## ⚠ CAUTION

### Burn Hazard!

Failure to follow this instruction could result in the unit overheating and becoming hot to the touch, which could result in minor or moderate injury, and/or equipment damage.

On electric heat units, certain parameter values are locked out to prevent overheating of the unit. These functions will appear to be saved; however, they will not be accepted if the Electric Heat Protection setting is "On". Do not change the Electric Heat Protection setting to "Off" and make changes to the protected settings unless you are programming an unconfigured service replacement board to match the unit settings on an ECM configuration label.

## NOTICE

### Equipment Damage!

Failure to follow instructions below could result in equipment damage.

- A single 24 Vac supply system must be used.
- Ensure proper polarity and grounding when connecting the 0 to 10 V system.

**Note:** Configuration adjustments to the motor control board should be made through the SMALLER of the two low-voltage lids on the front of the control panel, through the low-voltage insulation/shielding.

- The 0 to 10V (variable speed) inputs are available for use, but are not mandatory. The ECM system comes standard with three to five field-accessible thermostatic inputs (with adjustable speed), so the use of the 0 to 10V inputs is optional.
- All inputs are independently configurable and simultaneously accessible, and the motor control board will choose the highest user (configured and requested) speed. However, care should be taken with customer controls to avoid contention of signals.

The motor control board and adapter boards offer standard, normalizing 0 to 10V Variable speed fan inputs for use with field supplied controllers or thermostats. These inputs can be used as the only input to the system, used in addition to the thermostatic (H, M, L) inputs, or not used at all. The inputs are accessible via 1TB4 on the adapter boards.

The motor control board is factory configured to drive the unit to a minimum speed (catalogue "low speed" value), defined as  $R_{L\bar{1}}$  and  $R_{L\bar{2}}$  once the analog (0 to 10V) input is honored. As a default, the noise floor/threshold is set to 3 percent (0.3V). At 0.3V, the system will drive the motors to the speeds defined in defined as  $R_{L\bar{1}}$  and  $R_{L\bar{2}}$ . If the analogue input goes to 10V, the motor control board will drive the motor to maximum speed (normally catalogue high speed value), defined as  $R_{H\bar{1}}$  and  $R_{H\bar{2}}$ , and will change speed in response.

Although the VelociTach™ motor control board ships with settings that will work with most 0–10 Vdc outputs, calibration should be performed to maximize response range and controller authority. Typically, the only settings needed for the VSP inputs are calibration of the signal to ensure that the system obeys the following rules:

- The minimum output from the field supplied controller is met with a positive fan response. That is, we do not want the  $\mu F_{Lr}$  setting on the motor control board to be higher than the minimum output of the field supplied controller, as the motor control board will "ignore" a portion of the usable range of the customer fan variable speed output.
- The minimum output from the field supplied controller is not significantly greater than the floor setting  $\mu F_{Lr}$  floor. If the minimum output of the controller is significantly greater than the floor setting, the first point that the motor will turn on will be above the  $R_{L\bar{1}}$  and  $R_{L\bar{2}}$  value. The full range of motor control will not be fully utilized in this case, as the motor will never reach the low speed motor analogue input scaling value for Motor 1 and Motor 2 ( $R_{L\bar{1}}$  and  $R_{L\bar{2}}$ )
- The maximum output of the controller needs to be 10V, or if lower, needs to be compensated using the analog input scaling value,  $R_{\bar{5}c}$  to normalize the operational range. As a default, the scaling value is set to 1.00 (so a voltage of 5V will be graded as 5V); however, to compensate for long runs or lower max voltages (i.e., lower than 10.00), the scaling value can be increased accordingly to maximize operational range.

For example, if the voltage is only reaching a value of 9.0V at the adapter boards, then the  $R_{\bar{5}c}$  parameter should be set to  $(10/9) = 1.111$ . If left uncalibrated, the unit will never attain maximum speeds, defined as  $R_{H\bar{1}}$  and  $R_{H\bar{2}}$ .

- The motor control board can accept slightly over-biased inputs up to 12 Vdc, and the  $R_{\bar{5}c}$  parameter can be set to a value less than 1.0 to compensate.

## VSP Setup Examples

**Figure 67. Example 1:  $\mu F_{Lr}$  set too high and  $R_{\bar{5}c}$  set too high**

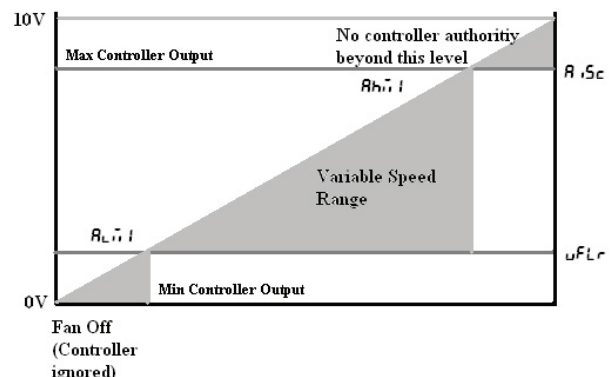

**Figure 68. Example 2:  $\mu F_{LR}$  set too high but  $R_{iSc}$  set correctly**

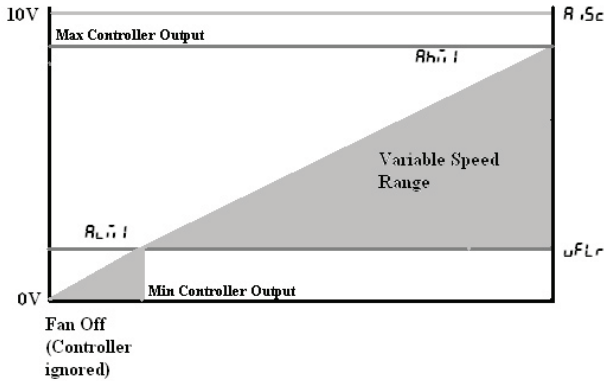

**Figure 69. Example 3:  $\mu F_{LR}$  set correctly and  $R_{iSc}$  set correctly**

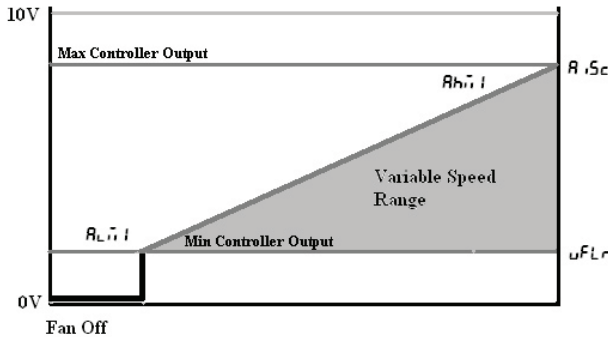

### Potentiometer/Rheostat For VSP

#### ⚠ WARNING

#### Hazardous Voltage w/Capacitors!

Failure to disconnect power and discharge capacitors before servicing could result in death or serious injury.

Disconnect all electric power, including remote disconnects and discharge all motor start/run capacitors before servicing. Follow proper lockout/tagout procedures to ensure the power cannot be inadvertently energized. Verify with a CAT III or IV voltmeter rated per NFPA 70E that all capacitors have discharged.

#### ⚠ WARNING

#### Safety Alert!

Failure to follow instructions below could result in death or serious injury.

All settings take effect immediately, including fan start and electric heat. Avoid hazardous voltage sources, moving parts, and electric heat elements when adjusting the motor control board. If avoiding these areas is not practical during motor control board adjustment, contact Trane Global Parts for configuration kit to power control board outside the unit with a 9-volt battery.

A courtesy 10 Vdc supply is provided that can support a 10mA draw. The use of a 1K or a 10K potentiometer is recommended, and only a stand-alone potentiometer (not shared with any other electrical system) should be employed. When a simple potentiometer is used as depicted in Figure 70, p. 72, the  $\mu F_{LR}$  setting will define a null-zone (off).

The typical connection is depicted in Figure 70, p. 72; however, please consult the unit schematic for the most updated instruction, as this is provided as reference only.

**Figure 70. Typical connection**

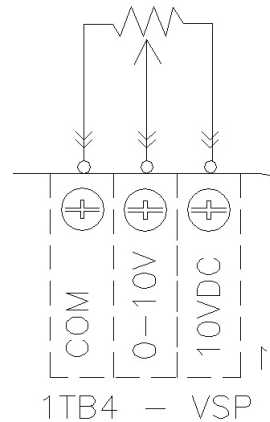

### Adjusting Optional Auto-Changeover Function on CSTI Units

#### ⚠ WARNING

#### Hazardous Voltage w/Capacitors!

Failure to disconnect power and discharge capacitors before servicing could result in death or serious injury.

Disconnect all electric power, including remote disconnects and discharge all motor start/run capacitors before servicing. Follow proper lockout/tagout procedures to ensure the power cannot be inadvertently energized. Verify with a CAT III or IV voltmeter rated per NFPA 70E that all capacitors have discharged.

The motor control board provides additional temperature controlled logic to help coordinate certain electric-heat and valve logic functions:

- On units with electric heat and a changeover coil, the motor control board and adapter boards are pre-configured to cause hydronic heat and electric heat to be mutually exclusive:
  - On units with BACnet® controls (Symbio™ 400-B), the Tracer controller board will serve as the primary logic to select the electric heat only if hot water is not available, but the motor control board will service as a backup lockout.
  - On units with Customer Supplied Controllers (CSTI units), the motor control board and CSTI board will serve as the primary lockout.
- On CSTI units selected with a changeover coil configuration, the motor control board is factory configured to work in conjunction with the CSTI adapter board to provide a useful auto-changeover function. Traditionally, a fixed setpoint bi-metallic disc temperature switch is used to provide changeover with customer controls; however, the motor control board has defeatable and configurable bi-metallic disc temperature switch emulation when combined with the CSTI adapter board. The motor control board is preconfigured for typical values, so changeover settings do not necessarily need to be changed.

**Note:** *CSTI board does not support changeover function with modulating valves.*

- An NTC thermistor is supplied and affixed to the supply pipes where applicable. The motor control board has several settings that affect the operation of the changeover function:
  - *FPru* parameter should normally be set to *EH<sub>L</sub>* or *EH<sub>F5</sub>* to use the changeover functions.
  - *EH<sub>L</sub>* parameter should be chosen if the unit has a changeover coil without electric heat.
  - *EH<sub>F5</sub>* parameter should be chosen if the unit has a changeover coil with electric heat. Generally, this will perform the same as the *EH<sub>L</sub>* parameter but in addition, will disable heating function on electric heat and on the changeover coil if there are fan failures. The auxiliary heating coil function will continue to operate and respond to the customer heating request.
- *APU* parameter should be set to *1 n* for CSTI units and to *0U<sub>L</sub>* for ComfortLink or BACnet® controller units.
- *A<sub>2T</sub>* parameter defines the temperature at which the motor control board will close the triac onboard the motor control board (if *FPru* parameter is set correctly).
- *A<sub>2b</sub>* parameter defines the temperature at which the motor control board will open the triac onboard the motor control board (if *FPru* parameter is set correctly). By leaving a “gap” between the make and break value, we will simulate hysteresis of a real bi-metallic disc temperature switch.

- When combined with the CSTI adapter board, the bi-metallic disc temperature switch emulation and the electric heat lockout function will work when the switches are set correctly.

## Configurations

Every Trane unit with ECM motors will have modules specifically configured at the factory for the operation of that unit. The motor control board configuration label is affixed to the low-voltage access lid on the outside of the control panel. The VelociTach™ motor control board label may be on the back-side of the low voltage access lid, depending on the unit configuration.

The serial number of each unit and the custom configuration settings specific to that unit will be printed on the label for convenient matching of labels/settings to specific units. Programming a unit with the settings from another unit will result in abnormal operation. The label contains four important sections:

- How to enter the configuration menu
- The description and meaning of the error codes
- The description and meaning of the status display
- The parameter names and values specific to that unit

## Motor Control Board Settings

### **WARNING**

#### **Safety Alert!**

**Failure to follow instructions below could result in death or serious injury.**

**All settings take effect immediately, including fan start and electric heat. Avoid hazardous voltage sources, moving parts, and electric heat elements when adjusting the motor control board. If avoiding these areas is not practical during motor control board adjustment, contact Trane Global Parts for configuration kit to power control board outside the unit with a 9-volt battery.**

### **CAUTION**

#### **Burn Hazard!**

**Failure to follow this instruction could result in the unit overheating and becoming hot to the touch, which could result in minor or moderate injury, and/or equipment damage.**

**On electric heat units, certain parameter values are locked out to prevent overheating of the unit. These functions will appear to be saved; however, they will not be accepted if the Electric Heat Protection setting is “On”. Do not change the Electric Heat Protection setting to “Off” and make changes to the protected settings unless you are programming an unconfigured service replacement board to match the unit settings on an ECM configuration label.**

## ECM Overview and Setup

### NOTICE

#### Motor Damage!

Failure to follow instructions below could result in motor damage.

Do not change PWM output voltage settings.

**Note:** The motor control board functions and unit specific settings are summarized on the motor control board configuration label affixed to the back side of the control panel low voltage lid, on every unit.

Table 23, p. 74 lists the parameter names and typical settings of the motor control board, for reference only.

Do not change the electric heat protection settings if your unit has electric heat.

If the format setting for rpm values are not correct (i.e., not four-digit: XXXX), please check the operation mode of the motor control board  $\overline{Mod 1}$  and  $\overline{Mod 2}$  and motor signal output format  $5: 9: 1$  and  $5: 9: 2$ .

**Note:** The following notes are provided for reference only, and the motor control board label must be used as the ultimate guide for setting up an motor control board on specific units.

**Table 23. Configuration settings of the motor control board (for reference only)**

| Description on Unit Label | User Interface Name | Typical User Interface Value | Description   |   |
|---------------------------|---------------------|------------------------------|---|---|
| Mtr 1 High Spd            | $H: 1$              | 1000                         | Sets the high-speed rpm for Motor 1.  | Do not exceed 2300 rpm.   |
| Mtr 1 Med Spd             | $\overline{Mod 1}$  | 777                          | Sets the medium-speed rpm for Motor 1.  |   |
| Mtr 1 Low Spd             | $L: 1$              | 632                          | Sets the low-speed rpm for Motor 1.   | Do not set under 600 rpm.   |
| EHStg1 Mtr1 Spd           | $E: 1: 1$           | 0                            | Assigns an rpm to be associated with a call for 1 <sup>st</sup> stage electric heat, for Motor 1 (only on units equipped with electric heat). | $E: 1: 1$ , $E: 1: 2$ , $E: 2: 1$ , $E: 2: 2$ settings are locked out on units with electric heat.  |
| EH Stg 2 Mtr 1 Spd        | $E: 2: 1$           | 0                            | Assigns an rpm to be associated with a call for 2 <sup>nd</sup> stage electric heat, for Motor 1 (only on electric heat equipped units).      |   |
| AI High Spd Mtr 1         | $AH: 1$             | 0                            | Sets the maximum rpm for Motor 1 for the maximum input value of the analog input.   | Analog inputs below the $\mu F L r$ setting will be rejected.   |
| AI Low Spd Mtr 1          | $AL: 1$             | 0                            | Sets the minimum turn-on rpm for Motor 1, when the analog input becomes active.   |   |
| Mtr 2 Hgh Spd             | $H: 2$              | 0                            | Sets the high-speed rpm for Motor 2.  | Blower coils have only one motor.   |
| Mtr 2 Med Spd             | $\overline{Mod 2}$  | 0                            | Sets the medium-speed rpm for Motor 2.  |   |
| Mtr 2 Low Spd             | $L: 2$              | 0                            | Sets the low-speed rpm for Motor 2.   |   |
| EHStg1 Mtr2 Spd           | $E: 1: 2$           | 0                            | Assigns an rpm to be associated with a call for 1 <sup>st</sup> stage electric heat, for Motor 2 (only on electric heat equipped units).      | If the unit has only one motor, all seven speed settings for the second motor ( $H: 2$ , $\overline{Mod 2}$ , $L: 2$ , $E: 1: 2$ , $E: 2: 2$ , $AL: 2$ , $AH: 2$ ) should be set to zero. |
| EH Stg 2 Mtr 2 Spd        | $E: 2: 2$           | 0                            | Assigns an rpm to be associated with a call for 2 <sup>nd</sup> stage electric heat, for Motor 2 (only on electric heat equipped units).      |   |
| AI High Spd Mtr 2         | $AH: 2$             | 0                            | Sets the maximum rpm for Motor 2 for the maximum input value of the analog input.   |   |
| AI Low Spd Mtr 2          | $AL: 2$             | 0                            | Sets the minimum turn-on rpm for Motor 2, when the analog input becomes active.   |   |
| Op Mode Mtr 1             | $\overline{Mod 1}$  | $rP: 1$                      | Sets the operational mode for Motor 1.  | Must be set to $rP: 1$ for blower coil units.   |
| Op Mode Mtr 2             | $\overline{Mod 2}$  | $rP: 1$                      | Sets the operational mode for Motor 2.  | Must be set to $rP: 1$ for blower coil units.   |
| Mtr 1 Out Format          | $5: 9: 1$           | $P: 1: 1$                    | Sets the interface type for Motor 1.  | Must be set to $P: 1: 1$ for blower coil units.   |
| Mtr 2 Out Format          | $5: 9: 2$           | $P: 1: 1$                    | Sets the interface type for Motor 2   | Must be set to $P: 1: 1$ for blower coil units.   |
| Mtr 1/2 PWM Freq.         | $F: E: 9$           | 100                          | Sets the PWM frequency, for cases when the PWM outputs are used.  | On blower coil units, the $P: 1: 1$ must not be changed.  |

**Table 23. Configuration settings of the motor control board (for reference only) (continued)**

| Description on Unit Label | User Interface Name          | Typical User Interface Value | Description   |  |
|---------------------------|------------------------------|------------------------------|---|--|
| Mtr 1 PWM Volt            | $\overline{v1v}$             | 5                            | Sets the PWM voltage, for cases when the PWM outputs are used.  | This setting must NOT be changed, as damage to the motor may occur!  |
| Mtr 2 PWM Volt            | $\overline{v2v}$             | 5                            | Sets the PWM voltage, for cases when the PWM outputs are used.  | This setting must NOT be changed, as damage to the motor may occur!  |
| Mt1 Hgh PWM Lt            | $\overline{v1h}$             | 90                           | Sets the maximum output percentage that the controller will request from Motor 1.   | This envelope protection value should not be altered.  |
| Mt1 Low PWM Lt            | $\overline{v1l}$             | 14.5                         | Sets the minimum maximum output percentage that the controller will request from Motor 1.   | This envelope protection value should not be altered.  |
| Mt2 Hgh PWM Lt            | $\overline{v2h}$             | 90                           | Sets the maximum output percentage that the controller will request from Motor 2.   | This envelope protection value should not be altered.  |
| Mt2 Low PWM Lt            | $\overline{v2l}$             | 14.5                         | Sets the minimum maximum output percentage that the controller will request from Motor 2.   | This envelope protection value should not be altered.  |
| Mt1 Ovspd RPM             | $r\overline{p1}$             | 2500                         | Selects the rpm above which the Motor 1 will be assumed to be in an overspeed condition and will need to be shutdown.                                       | This envelope protection value should not be altered.  |
| Mt2 Ovspd RPM             | $r\overline{p2}$             | 2500                         | Selects the rpm above which the Motor 2 will be assumed to be in an overspeed condition and will need to be shutdown.                                       | This envelope protection value should not be altered.  |
| Fan Proving Fct           | $F\overline{p}u$             | $F\overline{n}5t$            | Selects which mode should be assigned to the Binary output circuit, depending on unit type.   | This setting has to be correct for proper unit operation of electric heat and changeover units.                                    |
| AI Boost Amp              | $A\overline{i}5c$            | 1                            | Boosts or attenuates the analog input signal to compensate for long wire runs.  | A value of 1 should be used if no voltage level compensation is needed (i.e., voltage peak is at 10 Vdc).                          |
| AI Floor                  | $\overline{u}F\overline{l}r$ | 0.5                          | Rejects noise on the analog input lines and sets up the motor control board to turn on if the thermostat or controller is commanding its analog outputs on. |  |
| PulsePerRev               | $F\overline{d}bH$            | 18                           | Sets up the tachometer function to be compatible with the on-board motor and for correct speed calculation and calibration.                                 | Do not change this setting as this is critical to proper unit operation.   |
| P Value Mtr 1             | $P\overline{u}l1$            | 0.03                         | Sets up the on board closed loop control to control Motor 1 with proper stability.  | Do not change this setting.  |
| I Value Mtr 1             | $I\overline{u}l1$            | 0.03                         | Sets up the on board closed loop control to control Motor 1 with proper stability.  | Do not change this setting.  |
| P Value Mtr 2             | $P\overline{u}l2$            | 0.03                         | Sets up the on board closed loop control to control Motor 2 with proper stability.  | Do not change this setting.  |
| I Value Mtr 2             | $I\overline{u}l2$            | 0.03                         | Sets up the on board closed loop control to control Motor 2 with proper stability.  | Do not change this setting.  |
| Ht Sens Mk Val F          | $A\overline{i}2\overline{v}$ | 85                           | Sets the make value for the motor control board triac output based on the thermistor input.   | Operation also depends on $F\overline{p}r\overline{u}$ , $A\overline{i}2b$ , and $A\overline{i}P\overline{U}$ settings.            |
| Ht Sens Bk Val F          | $A\overline{i}2b$            | 90                           | Sets the break value for the motor control board triac output based on the thermistor input.  | Operation also depends on $F\overline{p}r\overline{u}$ , $A\overline{i}2\overline{v}$ , and $A\overline{i}P\overline{U}$ settings. |
| Ht Sens Resistor          | $A\overline{i}P\overline{U}$ | 0.1k                         | Sets the input impedance of the thermistor input.   | Should be pre-set to "OUT" for Tracer® ZN controllers.   |
| Mt 1 Ramp %/sec           | $\overline{r}1rP$            | 3                            | Sets the ramp rate for Motor 1, in % per second.  |  |
| Mt 2 Ramp %/sec           | $\overline{r}2rP$            | 3                            | Sets the ramp rate for Motor 2, in % per second   |  |
| EH Ramp Accel             | $E\overline{h}rP$            | 2                            | Sets the acceleration factor for the electric heat inputs.  | Is used to force faster ramps when electric heat is requested.   |

**Table 23. Configuration settings of the motor control board (for reference only) (continued)**

| Description on Unit Label | User Interface Name | Typical User Interface Value | Description   |   |
|---------------------------|---------------------|------------------------------|---|---|
| Ramp MAX Time             | $\bar{r}hrP$        | 15                           | Sets the maximum ramp time for both Motor 1 and Motor 2 (in seconds).   | Overrides the ramp rates $\bar{r}1rP$ and $\bar{r}2rP$ if the calculated ramp time exceeds $\bar{r}hrP$ .   |
| EH Fan off delay          | $EhDL$              | 15                           | Selects how long the fan needs to stay on after an electric heat request has been turned off.   |   |
| Lck Rtr Protect           | $LrPt$              | on                           | Selects whether to use the on-board locked rotor protection function.   | This will shutdown the affected motor, if rotational response is not detected.  |
| Protect Funct             | $EhPt$              | on                           | This function protects settings on the board that affect the safety of the electric heat system.  | Do NOT change this setting. This setting locks out the following parameters from being changed, for safe operation of the unit.<br>$RiPU$<br>$FPru$<br>$R\bar{r}H$<br>$R\bar{r}bH$<br>$E\bar{r}1$<br>$E\bar{r}2$<br>$E2\bar{r}1$<br>$E2\bar{r}2$<br>$S\bar{r}9$<br>$\bar{r}od1$<br>$\bar{r}od2$<br>$\bar{r}IH$<br>$\bar{r}ILo$  |
| Protect Funct             | $EhPt$              | FLR                          | This his function protects settings on the board that affect the safety of the electric heat system, and limit the maximum current the motor will draw under any operating condition. | Do NOT change this setting. This setting locks out the following parameters from being changed, for safe operation of the unit.<br>$E\bar{r}1$<br>$E2\bar{r}1$<br>$E\bar{r}2$<br>$E2\bar{r}2$<br>$\bar{r}Od1$<br>$\bar{r}Od2$<br>$S\bar{r}91$<br>$S\bar{r}92$<br>$\bar{r}IH1$<br>$\bar{r}IL0$<br>$\bar{r}2H1$<br>$\bar{r}2L0$<br>$FPru$<br>$R\bar{r}2\bar{r}$<br>$R\bar{r}2b$<br>$RiPU$ |
| Rmp dft (auto rst)        | $rPdF$              | oFF                          | This function shortens the ramps for faster unit commissioning and auto-resets to off after approximately 15 minutes of power-on operation.   | To aid in commissioning of the unit, for approximately 10–15 minutes, the ramps will be shortened to quickly observe proper unit behavior and response to speeds.   |
| Soft Rev                  | $SofE$              | $uH\_HH$                     | Displays the software version.  | Module should be received with most recent version.   |

## Fan Speed Response Verification

- After performing controller specific commissioning, observe the display on the motor control board with the power on, to the unit. The motor control board display should display a looping status indicator as follows:  
 $\bar{r}Er1 \rightarrow 0 \rightarrow \bar{r}Er2 \rightarrow 0 \rightarrow F5E1 \rightarrow 0FF \rightarrow F5E2 \rightarrow 0FF \rightarrow EhEn \rightarrow 0n$

### Notes:

- The  $EhEn$  indicator is unit-specific and may indicate "Off" at this point; refer to thermistor function for more information.
  - A representative fan speed of "1080" rpm are shown in the example below. Each unit is factory-configured differently and will have different settings for different fan speeds.
- While the unit remains on, exercise the fan controls on the unit, either directly or indirectly through request for

unit heat/cool. Observe the fan spinning, and then observe the fan display on the motor control board. It should display a looping status indicator as follows:

For a size 200, 300, 400, 600, or 800 unit (using typical unit operating fan speeds):

$\overline{1}t\overline{r}1 \rightarrow 1080 \rightarrow \overline{1}t\overline{r}2 \rightarrow 0 \rightarrow F5t1 \rightarrow 0n \rightarrow F5t2 \rightarrow$   
 $0FF \rightarrow EhEn \rightarrow 0n$

For a size 1000 or 1200 unit (using typical unit operating fan speeds):

$\overline{1}t\overline{r}1 \rightarrow 1080 \rightarrow \overline{1}t\overline{r}2 \rightarrow 1080 \rightarrow F5t1 \rightarrow 0n \rightarrow F5t2 \rightarrow$   
 $0n \rightarrow EhEn \rightarrow 0n$

**Note:** The *EhEn* indicator is unit-specific and may indicate Off at this point; refer to thermistor function for more information.

3. OPTIONAL:

While the fan is running, if practical, change the fan speeds and observe the display temporarily indicate:

$rR\overline{1}P$

Exercise all fan speeds to ensure positive unit response and to validate any field wiring.



# Start-Up

## Pre-Start-Up Checklist

Complete this checklist after installing the unit to verify all recommended installation procedures are complete before unit start-up. This does not replace the detailed instructions in the appropriate sections of this manual. Disconnect electrical power before performing this checklist. Always read the entire section carefully to become familiar with the procedures.

### **⚠ WARNING**

#### **Hazardous Voltage w/Capacitors!**

Failure to disconnect power and discharge capacitors before servicing could result in death or serious injury.

Disconnect all electric power, including remote disconnects and discharge all motor start/run capacitors before servicing. Follow proper lockout/tagout procedures to ensure the power cannot be inadvertently energized. Verify with a CAT III or IV voltmeter rated per NFPA 70E that all capacitors have discharged.

*Note: Some circumstances may require the unit to run before building construction is complete. These operating conditions may be beyond the design parameters of the unit and may adversely affect the unit.*

## General Checks

- Ensure the unit has been installed level.
- Ensure supply-air and return-air ducts have been connected.
- Ensure damper operator motors and connecting linkage have been installed.
- Verify damper operation and linkage alignment.
- Check that air filters are in place and positioned properly.
- Remove any debris from the unit interior.
- Remove all foreign material from the drain pan and check drain pan opening and condensate line for obstructions.
- Inspect electrical connections to the unit and unit controllers.
  - Connections should be clean and secure.
  - Compare the actual wiring with the unit diagrams.
  - Reference the appropriate controller manual for more details about starting units with factory-mounted controls.
- Check piping and valves for leaks. Open or close the valves to check for proper operation. Drain lines should be open.

- Leave this manual with the unit.

## Fan-Related

- Rotate fan wheel manually to confirm it turns freely in the proper direction.
- Verify the fan and motor are aligned.

## Coil-Related Checks

### **NOTICE**

#### **Proper Water Treatment Required!**

The use of untreated or improperly treated water could result in scaling, erosion, corrosion, algae or slime.

Use the services of a qualified water treatment specialist to determine what water treatment, if any, is required. Trane assumes no responsibility for equipment failures which result from untreated or improperly treated water, or saline or brackish water.

- Ensure coil and condensate drain piping connections are complete.
- Check the piping and valves for leaks.
  - Open or close the valves to check operation.
  - The drain lines should be open.
- Remove all foreign material from the drain pan and check the pan opening and condensate line for obstructions.
- For steam coils, slowly turn the steam on full for at least 10 minutes before opening the fresh air intake on units with fresh air dampers.

## Electrical Checks

- Check all electrical connections for tightness.
- Verify motor voltage and amps on all phases with the unit nameplate ratings to ensure unit operates correctly.

## Ductwork Checks

- If using return ductwork to the unit, secure it with three inches of flexible duct connector.
- Extend discharge duct upward without change in size or direction for at least one and one half fan diameters.
- Use a 3-inch flexible duct connection on discharge.
- Ensure trunk ductwork is complete and secure to prevent leaks.
- Verify that all ductwork conforms to NFPA 90A or 90B and all applicable local codes.

## Unit Start-Up

### Fan Speed Control

Figure 71. Fan speed control



The fan speed control can be used to provide simultaneous fan speed customer requests in addition to external controller fan speed request. The wall-mounted option is low-voltage and has three 24-volt relays using a factory-wired transformer and relays to control the fan motor.

### Fan Mode Switch Operation

#### Off

Fan is turned off, two-position damper option spring-returns closed.

#### On

Fan runs continuously at the selected speed. The two-position damper option opens to an adjustable mechanical stop position.

## Symbio™ 400-B Controller

Tracer® Symbio 400-B controller delivers single zone VAV control in a stand-alone operation or as part of a building automation system using BACnet® communications.

The Symbio™ 400/Symbio™ 400-B is a multi-purpose, programmable (or application-specific) controller that provides direct-digital zone temperature control. The controller can operate as a stand-alone device or as part of a building automation system (BAS). Communication between the controller and a BAS occurs on an open standard with inter-operable protocols used in Building Automation and Control Networks (BACnet®). Programming is done by means of the Tracer® TU service tool.

### Symbio™ 400-B Stand-Alone Operation

The factory pre-programs the Symbio™ 400-B with default values to control the temperature and unit airflow. Use Tracer® SC building automation system or Tracer® TU software to change the default values. For more information, refer to *Symbio™ 400-B/500 Programmable Controllers For Blower Coil, Fan Coil, and Unit Ventilator -*

*Installation, Operation, and Maintenance (BAS-SVX093\*-EN)*

Follow the procedure below to operate the Symbio™ 400-B in a stand-alone operation:

1. Turn power on at the disconnect switch option.
2. Position the fan mode switch to either high, medium, low, or the auto position.
3. Rotate the setpoint dial on the zone sensor module to 55°F for cooling or 85°F for heating.

The appropriate control valve will actuate assuming the following conditions:

- Room temperature should be greater than 55°F and less than 85°F.
- For a 2-pipe fan-coil unit with an automatic changeover sensor, the water temperature input is appropriate for the demand placed on the unit. For example, cooling operation is requested and cold water (5° lower than room temperature) flows into the unit.
- Select the correct temperature setpoint.

**Note:** *Select and enable zone sensor temperature settings to prevent freeze damage to unit.*

## Symbio™ 400-B Operation

### Controller

**Off** - Fan is off; control valves and fresh air damper option close. Low air temperature detection option is still active.

**Auto** - Fan speed control in the auto setting allows the modulating (3-wire floating point) or 2-position control valve option and 1-, 2-, 3- or variable-speed fan to work cooperatively to meet precise capacity requirement, while minimizing fan speed (motor/energy/acoustics) and valve position (pump energy, chilled water reset). As the capacity requirement increases, the water valve opens. When the fan speed capacity switch points are reached, the fan speed ramps up and the water valve repositions to maintain an equivalent capacity. The reverse sequence takes place with a decrease in required capacity.

**Low/Medium/High** - The fan runs continuously at the selected speed and the valve option will cycle to meet setpoint.

## Sequence of Operation

### Power-Up Sequence

When 24 Vac power is initially applied to the controller, the following sequence occurs:

1. The Power Marquee LED turns on as red, then flashes green, and then turns a solid green.
2. All outputs are controlled **OFF** and all modulating valves and dampers close.
3. The controller reads all input local values to determine initial values.
4. The random start timer begins (refer to “[Random Start,](#)” p. 80).



## Start-Up

---

5. The random start timer expires.
6. Normal operation begins, assuming there are no generated diagnostics. If any points are in fault or alarm mode, the Power Marquee LED flashes red.

**Important:** *Flashing red does not indicate that the controller will fail to operate. Instead, the point(s) that are in fault or alarm mode should be checked to determine if the status of the point(s) is acceptable to allow equipment operation.*

### Random Start

Random start is intended to prevent all units in a building from energizing at the same time. The random start timer delays the fan and any heating or cooling start-up from 5 to 30 seconds.

### Occupancy Modes

Occupancy modes can be controlled in the following ways:

- The state of the local (hard wired) occupancy binary input BI1.
- A timed override request from a Trane zone sensor (see “Occupancy Modes,” p. 80).
- A communicated signal from either a Tracer® SC or BAS.

A communicated request, from either a Tracer SC or BAS, takes precedence over local requests. If a communicated occupancy request has been established, and is no longer present, the controller reverts to the default (occupied) occupancy mode after 15 minutes (if no hard wired occupancy request exists). The controller has the following occupancy modes:

- Occupied
- Unoccupied
- Occupied standby
- Occupied bypass

### Occupied Mode

In Occupied Mode, the controller maintains the space temperature based on the occupied space temperature setpoint  $\pm$  occupied offset. The controller uses the occupied mode as a default mode when other forms of occupancy request are not present and the fan runs continuously. The outdoor air damper, if present, will close when the fan is OFF. The temperature setpoints can be local (hard wired), communicated, or stored default values (configurable using the Tracer® TU service tool).

### Unoccupied Mode

In unoccupied mode, the controller attempts to maintain the space temperature based on the unoccupied heating or cooling setpoint. The fan will cycle between high speed and OFF. In addition, the outdoor air damper remains closed, unless economizing. The controller always uses the stored default setpoint values (configurable using the Tracer® TU

service tool), regardless of the presence of a hard wired or communicated setpoint value.

### Occupied Standby Mode

The controller is placed in occupied standby mode only when a communicated occupied request is combined with an unoccupied request from occupancy binary input BI1. In occupied standby mode, the controller maintains the space temperature based on the occupied standby heating or cooling setpoints. Because the occupied standby setpoints have a typical temperature spread of 2°F (1.1°C) in either direction, and the outdoor air damper is closed, occupied standby mode reduces the demand for heating and cooling the space. The fan will run as configured (continuously) for occupied mode. The controller always uses the stored default setpoint values (configurable using the Tracer® TU service tool), regardless of hard wired or communicated setpoint values. In addition, the outdoor air damper uses the economizer occupied standby minimum position setpoint to reduce the ventilation rate.

### Occupied Bypass Mode

The controller is placed in occupied bypass mode when the controller is operating in the unoccupied mode and when either the timed override ON button on the Trane zone sensor is pressed or the controller receives a communicated occupied bypass signal from a BAS. In occupied bypass mode, the controller maintains the space temperature based on the occupied heating or cooling setpoints. The fan will run as configured (continuous or cycling). The outdoor air damper closes when the fan is OFF. The controller remains in occupied bypass mode until either the CANCEL button is pressed on the Trane zone sensor or the occupied bypass time (configurable using the Tracer® TU service tool) expires. The temperature setpoints can be configured as local (hard wired), communicated, or stored default values using the Tracer® TU service tool.

### Timed Override Control

If the controller has a timed override option (ON/CANCEL buttons), pushing the ON button initiates a timed override on request. A timed override on request changes the occupancy mode from unoccupied mode to occupied bypass mode. In occupied bypass mode, the controller controls the space temperature based on the occupied heating or cooling setpoints. The occupied bypass time, which resides in the controller and defines the duration of the override, is configurable from 0 to 240 minutes (default value of 120 minutes). When the occupied bypass time expires, the unit transitions from occupied bypass mode to unoccupied mode. Pushing the CANCEL button cancels the timed override request. In addition, it will end the timed override before the occupied bypass time has expired and transition the unit from occupied bypass mode to unoccupied mode.

If the controller is in any mode other than unoccupied mode when the **ON** button is pressed, the controller still starts the occupied bypass timer without changing to occupied

bypass mode. If the controller is placed in unoccupied mode before the occupied bypass timer expires, the controller is placed into occupied bypass mode and remains in this mode until either the **CANCEL** button is pressed on the Trane zone sensor or the occupied bypass time expires.

## Zone Temperature Control

The controller has three methods of zone temperature control:

- **Cascade zone control**—used in the occupied, occupied bypass, and occupied standby modes. It maintains zone temperature by controlling the discharge air temperature to control the zone temperature. The controller uses the difference between the measured zone temperature and the active zone temperature setpoint to produce a discharge air temperature setpoint. The controller compares the discharge air temperature setpoint with the discharge air temperature and calculates a unit heating/cooling capacity accordingly (refer to the illustration below). The end devices (outdoor air damper, valves, and so on) operate in sequence based on the unit heating/cooling capacity (0–100 percent).

**Figure 72. Cascade zone control**

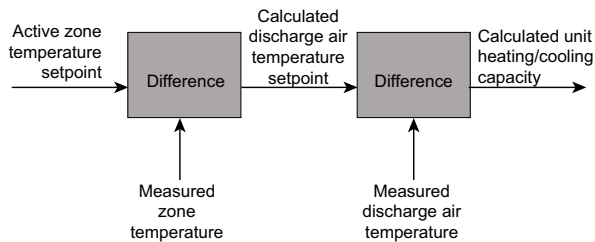

If the discharge air temperature falls below the discharge air temperature low limit setpoint, (configurable using the Tracer® TU service tool), and the cooling capacity is at a minimum, the available heating capacity is used to raise the discharge air temperature to the low limit (refer to “Discharge Air Tempering,” p. 81).

- **Simplified zone control**— if discharge air temperature failure occurs, then simplified zone controls runs. In the unoccupied mode, the controller maintains the zone temperature by calculating the required heating or cooling capacity (0–100%) according to the measured zone temperature and the active zone temperature setpoint. The active zone temperature setpoint is determined by the current operating modes, which include occupancy and heat/cool modes.
- **Discharge air temperature control**— is the backup mode that runs *only* if there is not valid zone temperature. In this mode, the active space temperature setpoint is used as the discharge air temperature setpoint.

**Important:** *This is not a normal operating mode. The source of the invalid zone temperature needs to be corrected to restore normal operation.*

## Discharge Air Tempering

If the controller is in cooling mode, cascade zone control initiates a discharge air tempering function when:

- The discharge air temperature falls below the discharge air temperature low limit setpoint (configurable using the Tracer® TU service tool).
- All cooling capacity is at a minimum. The discharge air tempering function allows the controller to provide heating capacity (if available) to raise the discharge air temperature to the discharge air temperature low limit setpoint.
- The cold outdoor air is brought in through the outdoor air damper and when the damper is at (high) minimum position. This causes the discharge air temperature to fall below the discharge air temperature low limit setpoint.

## Heating or Cooling Mode

The heating or cooling mode can be determined in one of two ways:

- By a communicated signal from a BAS or a peer controller
- Automatically, as determined by the controller

A communicated heating signal permits the controller to *only* heat and a communicated cooling signal permits the controller to *only* cool. A communicated auto signal allows the controller to automatically change from heating to cooling and vice versa.

In heating or cooling mode, the controller maintains the zone temperature based on the active heating setpoint and the active cooling setpoint, respectively. The active heating and cooling setpoints are determined by the occupancy mode of the controller.

For 2-pipe and 4-pipe changeover units, normal heat/cool operation *will not* begin until the ability to conduct the desired heating or cooling operation is verified. This is done using the entering water temperature sampling function, for which a valid entering water temperature is required. When neither a hard wired nor a communicated entering water temperature value is present on changeover units, the controller operates in *only* heating mode and assumes the coil water is hot. The sampling function is not used.

The entering water temperature sampling function is used *only* for changeover applications and for information and troubleshooting. It *does not* affect the operation of the controller. (For more information, refer to “Water Temperature Sampling Function,” p. 82.)



### Water Temperature Sampling Function

The entering water temperature sampling function is used with 2-pipe and 4-pipe changeover units and requires a valid entering water temperature value. If the entering water temperature value is less than 5°F (2.8°C) above a valid zone temperature value for hydronic heating, and greater than 5°F (2.8°C) below a valid zone temperature value for hydronic cooling, the sampling function is enabled. When the sampling function is enabled, the controller opens the main hydronic valve to allow the water temperature to stabilize. After 3 minutes, the controller again compares the entering water temperature value to the zone temperature value to determine if the desired heating or cooling function can be accomplished. If the entering water temperature value remains out of range to accomplish the desired heating/cooling function, the controller closes the main hydronic valve and waits 60 minutes to attempt another sampling. If the entering water temperature value falls within the required range, it resumes normal heating/cooling operation and disables the sampling function.

### Fan Operation

The controller supports 1-, 2-, 3-speed fans and variable-speed fans. The fan always operates continuously while either heating or cooling during occupied, occupied standby, and occupied bypass operation. During unoccupied operation, the fan cycles between **OFF** and **HIGH**, regardless of the fan configuration. When running in **AUTO** mode, the fan operates differently based on the mode and the type of fan.

For 1-, 2-, and 3-speed fans, each time the fan is enabled, the fan begins operation and runs on high speed for a period of time (0.5 seconds for fan coils and 3 seconds for fan coils) before changing to another speed. Initially running on high speed provides adequate torque to start the fan motor from the **OFF** position.

**Note:** *In occupied mode, the controller requires continuous fan operation because of cascade zone control. In unoccupied mode, the fan cycles.*

### Manual Fan Speed Control

Regardless of the fan type, the fan runs continuously at the desired fan speed during occupied, occupied standby, and occupied bypass operation as follows:

- When the controller receives a communicated fan speed signal (**HIGH, MEDIUM, LOW**)
- The associated fan speed switch is set to a specific fan speed
- The Supply Fan Speed Request point is overridden

During unoccupied operation, the fan cycles between **OFF** and **HIGH**, regardless of the communicated fan speed signal or fan speed switch setting (unless either of these is **OFF**, which in turn, will control the fan **OFF**).

The fan turns **OFF** when:

- The controller receives a communicated **OFF** signal

- The fan speed switch is set to **OFF**
- Specific diagnostics are generated
- The default fan speed is set to **OFF** and the fan is operating in the **AUTO** mode

**Note:** *The supply fan speed source can be configured for BAS, local, or default value control using the Tracer® TU service tool.*

### AUTO Fan Operation; 1-, 2-, 3-speed Fans

When the controller receives a communicated auto signal (or the associated fan speed switch is set to **AUTO** with no communicated value present), the fan operates in the **AUTO** mode. In **AUTO** mode, the fan operates according to the fan default (configurable using the Tracer® TU service tool). The fan speed has multiple speed configurations (default is **AUTO**) or set to **OFF** for both heating and cooling operation. When configured as **AUTO** (and with multiple speeds available), the fan changes based on the required capacity calculated by the control algorithm.

### AUTO Fan Operation; ECM Energy Efficient Mode

When the controller is configured for Energy Efficient Mode, by means of the Fan Operating Mode Request MV point, the controller and daughter board will minimize energy use by running the fan at the lowest possible speed while maintaining space temperature. The controller will fully utilize valves, economizer, or electric heat which increases fan speed to meet space temperature (unless the fan has been manually controlled. Refer to the preceding section.

### AUTO Fan Operation; ECM Acoustical Mode

When the controller is configured for Acoustical Mode, by means of the Fan Operating Mode Request MV point, the controller and daughter board will minimize acoustical nuisance by balancing changes in fan speed and total fan noise. The controller will fully **OPEN** cooling and heating valves before increasing fan speed to meet space temperature (unless the fan has been manually controlled. Refer to "Manual Fan Speed Control," p. 82 in the preceding section. If multiple stages of electric heat exist the controller will use a single minimum air flow for each stage.

### Exhaust Control

Exhaust control is achieved by a single-speed exhaust fan and controlled by binary output 2 (BO2). Exhaust control, if not present, can be enabled by selecting **Yes** under the *Exhaust Fan Selection* on the Tracer® TU Configuration page under the *Equipment Options* group.

**Note:** *Exhaust fan configuration cannot be selected with 3-speed fan operation.*

**Important:** If exhaust control is added to an existing configuration, all other configuration options should be verified to match the correct equipment options. Temperature and flow setpoints will revert to default values.

The exhaust function is coordinated with the supply fan and outdoor/return air dampers as follows:

- The exhaust fan energizes when the fan is running and when the outdoor air damper position is greater than or equal to the exhaust fan enable position (or the outside air damper position at which the exhaust fan turns **ON**).
- The exhaust fan turns **OFF** when the fan either turns **OFF** or the outdoor air damper closes to 10 percent below the exhaust fan enable position.
- If the exhaust fan/damper enable setpoint is less than 10 percent, the exhaust output is energized if the outdoor air damper position is at the setpoint and de-energized at 0.

### Valve Operation

The controller supports one or two modulating or two-position valves, depending on the application (see [Table 24, p. 83](#)). The controller opens and closes the appropriate valve(s) to maintain the active zone temperature setpoint at the heating setpoint in heating mode or the cooling setpoint in cooling mode (see [Figure 72, p. 81](#)).

### Three-Wire Modulating Valve Operation

The controller supports tri-state 3-wire modulating valve control. Two binary outputs control each valve: one to drive the valve open and one to drive the valve closed. The stroke time for each valve is configurable using the Tracer® TU service tool. The controller supports the following:

- Heating
- Cooling
- Heat/cool changeover with a single valve and coil for 2-pipe applications
- Cooling or heat, cool changeover with the main valve, and coil
- Only heating with the auxiliary valve and coil for 4-pipe applications

The controller moves the modulating valve to the desired positions based on heating or cooling requirements.

### Three-Wire Modulating Valve Calibration

Modulating valve calibration is automatic. During normal controller operation, the controller overdrives the actuator (135 percent of the stroke time) whenever there is a request for a position of 0 percent or 100 percent. At either power-up, after a power outage, or when the occupancy status changes to unoccupied, the controller first drives all modulating valves (and dampers) to the closed position. The controller calibrates to the fully **CLOSED** position by over driving the actuator (135 percent of the stroke time). Thereafter, the controller resumes normal operation.

### Two-position Valve Operation

The controller supports two-position valves with a single binary output for each valve. Controllers used for 2-pipe applications support heating, cooling, or heat/cool changeover with a single valve/coil. A controller used for 4-pipe applications supports cooling or heat/cool changeover with a main valve/coil and heating only with an auxiliary valve/coil.

### Modulating Outdoor/Return Air Damper

The controller operates the modulating outdoor/return air dampers based on the following:

- Occupancy mode
- Outdoor air temperature (communicated or hard wired sensor)
- Zone temperature
- Setpoint
- Discharge air temperature
- Discharge air temperature setpoint

The minimum position for an outdoor air damper is configurable using the Tracer® TU service tool for both occupied mode and occupied standby mode and for low-speed fan operation. A controller can receive a BAS-communicated outdoor air damper minimum position.

A BAS-communicated minimum position setpoint has priority over all locally configured setpoints. When a communicated minimum position setpoint is not present, the controller uses the configured minimum position for low fan speed whenever the fan is running at low speed, regardless of the occupancy state. See [Table 24, p. 83](#) and [Table 25, p. 84](#) for more information about how the controller determines the position of the modulating outdoor air damper.

**Table 24. Modulating outdoor air damper position setpoint determination**

| Occupancy                                       | BAS-communicated Setpoint | Fan speed | Active Minimum Setpoint  |
|---|---------------------------|-----------|--------------------------|
| Unoccupied                                      | Any value                 | Any value | 0 percent (closed)       |
| Occupied<br>Occupied bypass<br>Occupied standby | Valid                     | Any value | BAS-communicated         |
| Occupied<br>Occupied bypass<br>Occupied standby | Invalid                   | Low       | Occupied low fan minimum |



## Start-Up

**Table 24. Modulating outdoor air damper position setpoint determination (continued)**

| Occupancy                   | BAS-communicated Setpoint | Fan speed   | Active Minimum Setpoint  |
|-----------------------------|---------------------------|-------------|--------------------------|
| Occupied<br>Occupied bypass | Invalid                   | Medium/high | Occupied minimum         |
| Occupied standby            | Invalid                   | Medium/high | Occupied standby minimum |

**Table 25. Relationship between outdoor temperature sensors and damper position**

| Outdoor Air Temperature  | Modulating outdoor air damper position   |  |  |
|--|--|--|--|
|  | Occupied or Occupied Bypass  | Occupied Standby   | Unoccupied   |
| No or invalid outdoor air temperature  | Open to occupied minimum position  | Open to occupied standby minimum position  | Closed   |
| Failed outdoor air sensor  | Open to occupied minimum position  | Open to occupied standby minimum position  | Closed   |
| Outdoor air temperature present and economizing possible (refer to "Economizing (Free Cooling)," p. 84).     | Economizing; damper controlled between occupied minimum position and 100 percent | Economizing; damper controlled between occupied standby minimum position and 100 percent | Open and economizing during unit operation; otherwise closed |
| Outdoor air temperature present and economizing not possible (refer to "Economizing (Free Cooling)," p. 84). | Open to occupied minimum position  | Open to occupied standby minimum position  | Closed   |

### Economizing (Free Cooling)

Cooling with outdoor air (during the times when the temperature is low enough to allow) is referred to as economizing (free cooling). The controller and applications with modulating outside air damper, support economizing. The modulating outdoor air damper provides the first source of cooling for the controller.

The controller initiates economizing if the outdoor air temperature is below the economizer enable point (configurable using the Tracer® TU service tool). If economizing is initiated, the controller modulates the outdoor air damper (between the active minimum damper position and 100 percent) to control the amount of outdoor air cooling capacity. When the outdoor air temperature rises 5° F (2.8° C) above the economizer enable point, the controller disables economizing and moves the outdoor air damper back to its predetermined minimum position, based on the current occupancy mode or communicated minimum outdoor air damper position. If an outdoor air temperature value is not present, economizing is disabled.

### Modulating Outdoor Air Damper

The controller supports two-position outdoor air damper actuators. However, a modulating outdoor/return air damper actuator can be used for two-position control. Two-position control can be achieved by not providing an outdoor air temperature (neither hard wired nor communicated) to the controller, and by setting the damper minimum position (using the Tracer® TU service tool) to the desired value, typically 100 percent.

### Electric Heat Operation

The controller supports both SCR (modulating) and staged electric heat (1- or 2-stages). SCR heat is *only* a field-

installed option. In a unit configured with staged electric heat, the electric heating circuit(s) are cycled **ON** and **OFF** appropriately to maintain the desired space temperature at the active heating setpoint. In a unit configured with SCR (modulating) electric heat, the controller will send a 0 to 10 Volt DC signal to adjust SCR capacity in order to maintain the desired space temperature.

In both staged and modulating electric heat applications, the simultaneous use of electric and hydronic heat is not supported and the controller will operate electric heat *only* when hot water is *not* available (for example, in a changeover unit). In addition, the controller will run the supply fan for 30 seconds after electric heat is turned **OFF** in order to dissipate heat from the unit.

**Note:** This delay does not apply to steam or hydronic heating.

Factory-configured electric heat units have built-in mechanical protections to prevent dangerously high discharge air temperatures.

### Dehumidification Operation

The controller supports space dehumidification when:

- Mechanical (DX or hydronic) cooling is available
- The heating capacity is located in the reheat position
- The space relative humidity is valid

The space relative humidity can be a BAS-communicated value or come directly from a wired relative humidity sensor. The controller begins to dehumidify the space when the space humidity exceeds the humidity setpoint. The controller continues to dehumidify until the sensed humidity falls below the setpoint minus the relative humidity offset.

## Peer-to-Peer Communication

Peer-to-peer communication is accomplished by means of custom TGP2 programming in the Tracer® SC system controller or via hard wiring *only* between controllers.

## Unit Protection Strategies

The following unit protection strategies are initiated when specific conditions exist in order to protect the unit or building from damage:

- Smart reset
- Low coil temperature protection
- Condensate overflow
- Fan status
- Fan off delay
- Filter maintenance timer
- Freeze avoidance
- Freeze protection (discharge air temperature low limit)

### Smart Reset

The controller will automatically restart a unit that is locked out as a result of a **Low Coil Temp Detection (BI3)** diagnostic. Referred to as *smart reset*, this automatic restart will occur 30 minutes after the diagnostic occurs. If the unit is successfully restarted, the diagnostic is cleared. If the unit undergoes another **Low Coil Temp Detection** diagnostic within a 24-hour period, the unit will be locked out until it is manually reset.

**Note:** Freeze protection will also perform a smart reset.

### Low Coil Temperature Protection

For more information, refer to *Symbio™ 400-B/500 Programmable Controllers For Blower Coil, Fan Coil, and Unit Ventilator - Installation, Operation, and Maintenance (BAS-SVX093\*-EN)* and “Smart Reset,” p. 85.

### Condensate Overflow

For more information, refer to *Symbio™ 400-B/500 Programmable Controllers For Blower Coil, Fan Coil, and Unit Ventilator Installation, Operation, and Maintenance (BAS-SVX093\*-EN)*.

### Fan Status

In 1-, 2- and 3-speed fans, the status is based on the statuses of the supply fan output multistate and analog points dedicated to fan control. The fan status is reported as **HIGH, MEDIUM, LOW**, and as a percentage, whenever the fan is running. The fan status is reported as **OFF** whenever the fan is not running. In addition, a fan status switch can be connected to binary input 5 (BI5) to monitor the status of the fan for belt-driven or direct-driven units (except Trane Macon factory ECM fan motor units). The fan status switch provides feedback to the controller as follows:

- If the fan is not operating when the controller has the fan controlled to **ON**, the controller generates a *Low Airflow-Supply Fan Failure* diagnostic.
- If the controller energizes the fan output for 1 minute, and the fan status switch indicates no fan operation, the controller performs a unit shutdown and generates a *Low Airflow-Supply Fan Failure* diagnostic.

If the fan has been operating normally for one minute, but the fan status switch indicates no fan operation, the same diagnostic is generated.

This manual diagnostic discontinues unit operation until the diagnostic has been cleared from the controller. If a diagnostic reset is sent to the controller, and the fan condition still exists, the controller attempts to run the fan for 1 minute before generating another diagnostic and performing a unit shutdown. A diagnostic reset can be sent to the controller from the Tracer® TU *Alarms* page or by temporarily overriding the *Reset Diagnostic Request* on the Tracer TU *Binary Status* page.

**Note:** In the ECM fan application, the *VelociTach™* board will monitor the status of the fan. In case of a failure, the engine board will disable the motor immediately, and the low airflow diagnostic is sent.

### Fan Off Delay

After heating has been controlled OFF, the controller keeps the fan energized for an additional 30 seconds in order to remove residual heat from the heating source.

### Filter Maintenance Timer

The filter maintenance timer tracks the amount of time (in hours) that the fan is enabled. The Filter Runtime Hours Setpoint (configurable using the Tracer® TU service tool) is used to set the amount of time until maintenance (typically, a filter change) is required. The timer can be enabled/disabled from the **Supply Fan** group on the **Setup Parameters** page in Tracer TU.

The controller compares the fan run time to filter runtime hours setpoint. Once the setpoint is reached, the controller generates a **Filter Change Required** diagnostic. When the diagnostic is cleared, the controller resets the filter maintenance timer to zero, and the timer begins accumulating fan run time again. The diagnostics can be cleared and the filter timer reset by temporarily overriding the **Filter Timer Reset Request** on the **Binary Status** page or by using the reset button on the **Alarms** page in Tracer TU.

### Freeze Avoidance

Freeze avoidance is used for low ambient temperature protection. It is initiated *only* when the fan is **OFF**. The controller enters the freeze avoidance mode when the outdoor air temperature is below the freeze avoidance setpoint (configurable using the Tracer® TU service tool). The controller disables freeze avoidance when the outdoor air temperature rises 3° F (1.7° C) above the freeze avoidance setpoint.



## Start-Up

---

The following occurs when the controller is in freeze avoidance mode:

- Valves are driven open to allow water to flow through the coil
- Fan is **OFF**
- Economizing is disabled
- The outdoor/return air damper is closed
- DX cooling is **OFF**
- Electric heat stages are **OFF**

### Freeze Protection (Discharge Air Temperature Low Limit)

The controller monitors the discharge air temperature with a 10 kW thermistor wired to AI4. The freeze protection operation is initiated whenever the discharge air temperature falls below the discharge air temperature low limit. The discharge air temperature low limit is configurable using the Tracer® TU service tool. During freeze protection, the controller increases the heating capacity or decreases the cooling capacity in order to raise the discharge air temperature above the low limit. If the discharge air temperature remains below the low limit for 3 minutes, the controller generates a **Discharge Air Temp Limit** diagnostic.

Freeze protection will also perform a smart reset. Refer to "Smart Reset," p. 85.



# Maintenance

## ⚠ WARNING

### Hazardous Service Procedures!

Failure to follow all precautions in this manual and on the tags, stickers, and labels could result in death or serious injury.

Technicians, in order to protect themselves from potential electrical, mechanical, and chemical hazards, **MUST** follow precautions in this manual and on the tags, stickers, and labels, as well as the following instructions: **Unless specified otherwise, disconnect all electrical power including remote disconnect and discharge all energy storing devices such as capacitors before servicing. Follow proper lockout/tagout procedures to ensure the power can not be inadvertently energized. When necessary to work with live electrical components, have a qualified licensed electrician or other individual who has been trained in handling live electrical components perform these tasks.**

## ⚠ WARNING

### Rotating Components!

Failure to disconnect power before servicing could result in rotating components cutting and slashing technician which could result in death or serious injury.

**Disconnect all electric power, including remote disconnects before servicing. Follow proper lockout/tagout procedures to ensure the power can not be inadvertently energized.**

The following maintenance procedures apply to all types of unit ventilators - chilled water, hot water, split systems, and electric. Split system unit ventilators include a condensing unit. The instructions provided with the condensing unit apply to the entire refrigerant system.

Additional information for controls provided from supplier other than Trane should be obtained from the controls manufacturer.

## Maintenance Checklist

| Frequency                 | Maintenance  |
|---------------------------|--|
| Every week                | Observe unit weekly for any change in running condition and unusual noise.   |
| Every month               | Clean or replace air filters if clogged or dirty.  |
| Every three to six months | <ul style="list-style-type: none"> <li>Manually rotate the fan wheel to check for obstructions in the housing or interference with fan blades. Remove any obstructions and debris.</li> <li>Check motor bracket torque.</li> <li>Inspect and clean drain pan.</li> <li>Inspect coils for dirt build-up. Clean fins if airflow is clogged.</li> <li>Inspect and clean insulation.</li> </ul>  |
| Every year                | <ul style="list-style-type: none"> <li>Inspect the unit casing for chips corrosion. If damage is found, clean and repaint.</li> <li>Clean the fan wheels. Remove any rust from the shaft with an emery cloth and recoat with L.P.S. 3 or equivalent.</li> <li>Inspect and clean drain pans.</li> <li>Inspect and clean coils.</li> <li>Check damper linkages, fan set screws, and blade adjustment. Clean, but do not lubricate, the nylon damper rod bushings.</li> <li>Clean damper operators.</li> <li>Inspect, clean, and tighten all electrical connections and wiring.</li> <li>Rotate the fan wheel and check for obstructions. The wheel should not rub. Adjust the center if necessary.</li> <li>Examine flex connections for cracks or leaks. Repair or replace damaged material.</li> </ul> |

## Service Access

To access the unit for water balancing, motor access or other start-up and maintenance functions, use one of the following methods:

- Remove the end pocket front panel.
- Remove the return air grille by releasing the mounting screws.
- If there is no shelving or other obstructions, removing the end panel may allow more access.

## Air Filters

### ⚠ WARNING

#### Rotating Components!

Failure to disconnect power before servicing could result in rotating components cutting and slashing technician which could result in death or serious injury.

Disconnect all electric power, including remote disconnects before servicing. Follow proper lockout/tagout procedures to ensure the power can not be inadvertently energized.

Always install filters with directional arrows pointing toward the fan. Filters supplied with unit ventilators are specially designed for high lint content. Depending on room conditions, they will need to be replaced every four to eight weeks. Overloaded filters will reduce air handling capacity,

which may result in insufficient heating during the morning warm-up period and loss of natural cooling capacity during mild weather.

For units with high efficiency filters (MERV 8 or MERV 13), the filters need to be replaced with equivalent MERV-rated filters to maintain unit performance.

### NOTICE

#### Equipment Damage!

Failure to follow instructions below could result in equipment damage.

Do not operate units for any length of time without properly installing all panels, filters, and grilles.

The air filter on the vertical unit ventilator is located near the bottom of the unit.

**Table 26. Filter size (inches) and quantity**

| Filter Type        | Unit Size       |                                    |                                    |                                    |
|--------------------|-----------------|------------------------------------|------------------------------------|------------------------------------|
|                    | 0750            | 1000                               | 1250                               | 1500                               |
| Nominal filter     | 14 x 20 x 1 (2) | 14 x 24 x 1 (1)<br>14 x 30 x 1 (1) | 14 x 20 x 1 (2)<br>14 x 24 x 1 (1) | 14 x 24 x 1 (2)<br>14 x 30 x 1 (1) |
| Dynamic air filter | 7 x 42 x 1 (1)  | 7 x 54 x 1 (1)                     | 7 x 66 x 1 (1)                     | 7 x 78 x 1 (1)                     |

To remove filters:

1. Remove front panel.
2. Slide filter out of filter rack.
3. Place clean filter in rack.
4. Reattach front panel.

**Figure 73. Drain pan/fan/motor board assembly**

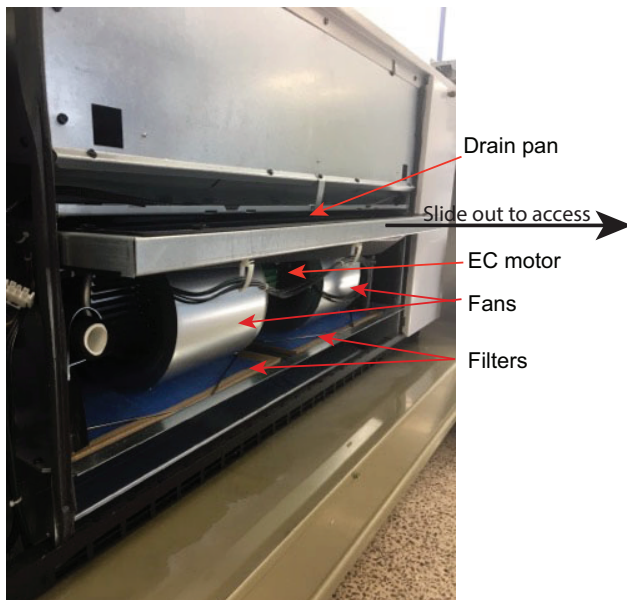

## Drain Pan/Fan/Motor Board Assembly

### ⚠ WARNING

#### Hazardous Voltage!

Failure to disconnect power before servicing could result in death or serious injury.

Disconnect all electric power, including remote disconnects before servicing. Follow proper lockout/tagout procedures to ensure the power can not be inadvertently energized. Verify that no power is present with a voltmeter.

### NOTICE

#### Equipment Damage!

Failure to follow instructions below could result in equipment damage.

Before removing bolts that support the fanboard, provide support to prevent the deck from falling out of the unit.

The drain pan, fan(s) and motor is on one assembly. To access:

1. Turn off power to the unit and remove the front panel.
2. Disconnect the condensate drain line from the P-trap.

**Figure 74. Disconnect drain line from P-trap**

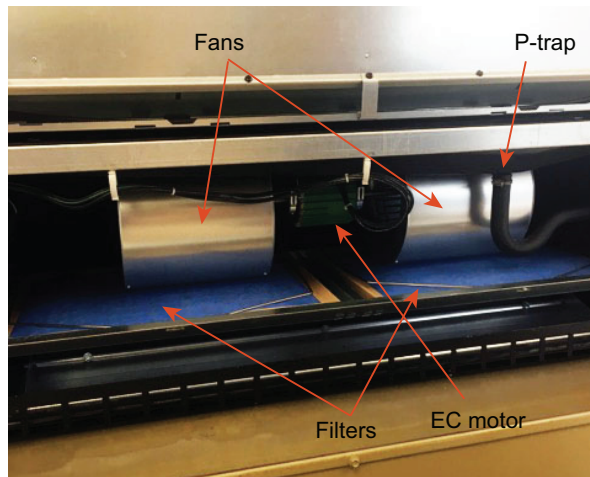

3. Disconnect fan plug.
4. Disconnect fan board ground wire.

**Figure 75. Disconnect fan board ground wire**



5. Slide assembly out.

## Cleaning Drain Pan

### **⚠ WARNING**

#### **Hazardous Chemicals!**

Failure to follow this safety precaution could result in death or serious injury. Coil cleaning agents can be either acidic or highly alkaline and can burn severely if contact with skin or eyes occurs.

Handle chemical carefully and avoid contact with skin. **ALWAYS** wear Personal Protective Equipment (PPE) including goggles or face shield, chemical resistant gloves, boots, apron or suit as required. For personal safety refer to the cleaning agent manufacturer's Materials Safety Data Sheet and follow all recommended safe handling practices.

The condensate drain pan and drain line must be checked to assure the condensate drains as designed. This inspection should occur a minimum of every six months or more often as dictated by operating experience. If evidence of standing water or condensate overflow exists, identify and remedy the cause immediately. Refer to "Diagnostics

and Troubleshooting," p. 94 for possible causes and solutions.

1. Disconnect all electrical power to the unit.
2. Remove four pan clips located at each end of the pans front.



3. Remove drain pan for cleaning.
4. When reinstalling, reverse sequence.
5. Wearing the appropriate personal protective equipment, remove any standing water.
6. Scrape solid matter off of the drain pan.
7. Vacuum the drain pan with a vacuum device that uses HEPA filters with a minimum efficiency of 99.97 percent at 0.3 micron particle size.
8. Thoroughly clean any contaminated area(s) with a mild bleach and water solution or an EPA-approved sanitizer specifically designed for HVAC use.
9. Immediately rinse the affected surfaces thoroughly with fresh water and a fresh sponge to prevent potential corrosion of metal surfaces.
10. Allow the unit to dry completely before putting it back into service.
11. Be careful any contaminated material does not contact other areas of the unit or building. Properly dispose of all contaminated materials and cleaning solution.

## Inspecting and Cleaning Fans

### **⚠ WARNING**

#### **Hazardous Voltage!**

Failure to disconnect power before servicing could result in death or serious injury.

Disconnect all electric power, including remote disconnects before servicing. Follow proper lockout/tagout procedures to ensure the power can not be inadvertently energized. Verify that no power is present with a voltmeter.

**⚠ WARNING**

**Rotating Components!**

Failure to disconnect power before servicing could result in rotating components cutting and slashing technician which could result in death or serious injury.

Disconnect all electric power, including remote disconnects before servicing. Follow proper lockout/tagout procedures to ensure the power can not be inadvertently energized.

Fans should be inspected every six months at a minimum or more frequently if operating experience dictates. If evidence of microbial growth (mold) is found, identify and remedy the cause immediately. Refer to “Diagnostics and Troubleshooting,” p. 94 for possible causes and solutions. To clean the fan section:

1. Disconnect all electrical power to the unit.
2. Wearing the appropriate personal protective equipment, remove any contamination.
3. Vacuum the section with a vacuum device that uses high-efficiency particulate arrestance (HEPA) filters with a minimum efficiency of 99.97 percent at 0.3 micron particle size.
4. Thoroughly clean any contaminated area(s) with a mild bleach and water solution or an EPA-approved sanitizer specifically designed for HVAC use.
5. Immediately rinse the affected surfaces thoroughly with fresh water and a fresh sponge to prevent potential corrosion of metal surfaces.
6. Allow the unit to dry completely before putting it back into service.
7. Be careful any contaminated material does not contact other areas of the unit or building. Properly dispose of all contaminated materials and cleaning solution.

Inspect fan motors periodically for excessive vibration or temperature. Operating conditions will vary the frequency of inspection.

**Torque Rating**

Check and adjust fan wheel set screws whenever a component is removed or an adjustment is made. Refer to the following table for recommendations.

**Table 27. Recommended torques**

|                 | Torque (in·lb) | Ft·lb     | N·m       |
|-----------------|----------------|-----------|-----------|
| Fan wheel screw | 120–130        | 10.0–10.8 | 13.6–14.7 |

**Figure 76. Routing motor and crossover harnesses**

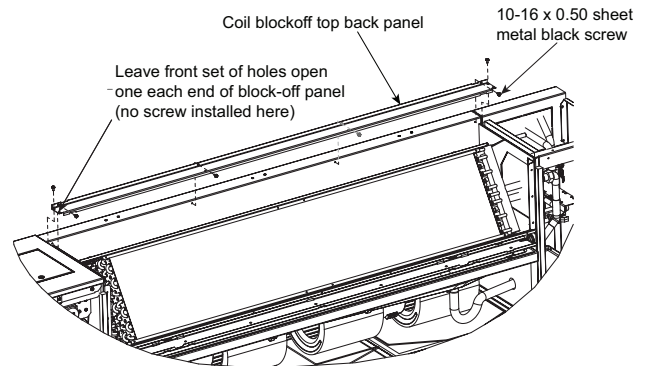

- Wiring to the motor transitions from the control panel onto a trough onto the fan board.
- The motor harnesses are routed through holes below the fan board and into the motors with a latching multi-plug.
- The crossover harnesses, which are used to make connections to the piping side of the unit, are routed entirely through the trough on the fan board to the piping.
- Fan board attachment screws are located on the front left and right edges of fan boards, and may be concealed by gasketing.

**Figure 77. Motor attachment screws are behind motor**

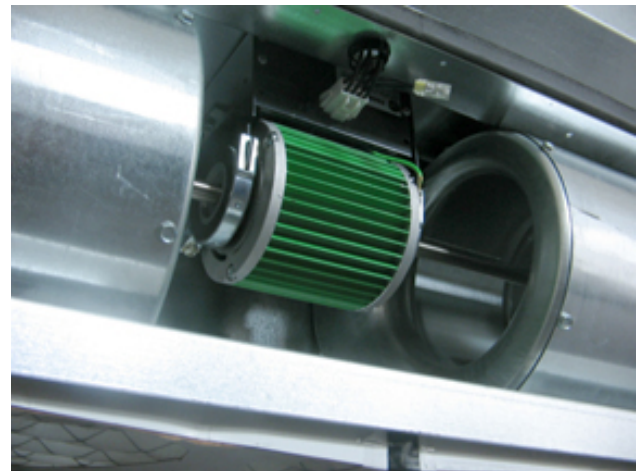

### ⚠ WARNING

#### Hazardous Voltage w/Capacitors!

Failure to disconnect power and discharge capacitors before servicing could result in death or serious injury.

Disconnect all electric power, including remote disconnects and discharge all motor start/run capacitors before servicing. Follow proper lockout/tagout procedures to ensure the power cannot be inadvertently energized. Verify with a CAT III or IV voltmeter rated per NFPA 70E that all capacitors have discharged.

1. Remove front panels of unit.
2. Remove drain pan and drain pan support.
3. Free the motor and crossover harnesses from the fan board, either by unplugging from the motors and valves and threading backwards, or by unplugging the motor plug from the adapter boards.
4. Remove at least one fan housing and loosen fan Allen screw on first fan. Loosen the wheel of the other (if a double-shafted motor).
5. Unscrew the motor and remove.
6. Insert the replacement motor (plug must face front of fan board) and drive the screws in with 100 in.lb of torque.

## Coil Cleaning

Periodically the hydronic coils should be cleaned from dirt accumulation that could reduce the unit performance. To clean the equipment coil:

1. Remove the units front panel.
2. Remove the units front nosing.
3. Removed the coils solid steel front cover.
4. Vacuum the dust/particles from the coil face.
5. Reverse order for re-installation.

All coils should be kept clean to maintain maximum performance.

## Steam and Water Coils

### ⚠ WARNING

#### Hazardous Voltage!

Failure to disconnect power before servicing could result in death or serious injury.

Disconnect all electric power, including remote disconnects before servicing. Follow proper lockout/tagout procedures to ensure the power can not be inadvertently energized. Verify that no power is present with a voltmeter.

### ⚠ WARNING

#### Hazardous Chemicals!

Failure to follow this safety precaution could result in death or serious injury. Coil cleaning agents can be either acidic or highly alkaline and can burn severely if contact with skin or eyes occurs.

Handle chemical carefully and avoid contact with skin. **ALWAYS** wear Personal Protective Equipment (PPE) including goggles or face shield, chemical resistant gloves, boots, apron or suit as required. For personal safety refer to the cleaning agent manufacturer's Materials Safety Data Sheet and follow all recommended safe handling practices.

To clean steam and water coils:

1. Disconnect all electrical power to the unit.
2. Wearing the appropriate personal protective equipment, use a soft brush to remove loose debris from both sides of the coil.
3. Install a block-off to prevent spray from going through the coil and into a dry section of the unit and/or system ductwork.
4. Mix a high-quality coil cleaning detergent with water according to the manufacturers instructions.
 

*Note: If the detergent is strongly alkaline after mixing (PH 8.5 or higher), it must contain an inhibitor. Follow the cleaning solution manufacturer's instructions regarding the use of the product.*
5. Place the mixed solution in a garden pump-up sprayer or high-pressure sprayer. If a high pressure sprayer is to be used:
  - Maintain minimum nozzle spray angle of 15 degrees.
  - Spray perpendicular to the coil face.
  - Keep the nozzle at least 6 inches from the coil.
6. Thoroughly rinse the coil and the drain pan with cool, clean water.
7. Straighten any coil fins that may have been damaged during the cleaning process.
8. Confirm the drain line is open following the cleaning process.
9. Allow the unit to dry thoroughly before putting it back into service.
10. Replace all panels and parts and restore electrical power to the unit.
11. Be careful any contaminated material does not contact other areas of the unit or building. Properly dispose of all contaminated materials.

## Refrigerant Coils

### **⚠ WARNING**

#### **Hazardous Pressures!**

**Failure to follow instructions could result in coil bursting, which could result in death or serious injury. Coils contain refrigerant under pressure. To avoid excessive pressure in the coil, do not exceed 150°F coil cleaning solution temperature.**

To clean refrigerant coils:

1. Disconnect all electrical power to the unit.
2. Wearing the appropriate personal protective equipment, use a soft brush to remove loose debris from both sides of the coil.
3. Install a block-off to prevent spray from going through the coil and into a dry section of the unit and/or system ductwork.
4. Mix a high-quality coil cleaning detergent with water according to the manufacturers instructions.

**Note:** *If the detergent is strongly alkaline after mixing (PH 8.5 or higher), it must contain an inhibitor. Follow the cleaning solution manufacturer's instructions regarding the use of the product.*

5. Place the mixed solution in a garden pump-up sprayer or high-pressure sprayer. If a high pressure sprayer is to be used:
  - Maintain minimum nozzle spray angle of 15 degrees.
  - Spray perpendicular to the coil face.
  - Keep the nozzle at least 6 inches from the coil.
6. Spray the leaving air side of the coil first, then the entering air side.
7. Thoroughly rinse both sides of the coil and the drain pan with cool, clean water.
8. Repeat [Step 1](#) and [Step 2](#) as necessary.
9. Straighten any coil fins damaged during the cleaning process.
10. Confirm the drain line is open following the cleaning process.
11. Allow the unit to dry thoroughly before putting it back into service.
12. Replace all panels and parts and restore electrical power to the unit.
13. Be careful any contaminated material does not contact other areas of the unit or building. Properly dispose of all contaminated materials and cleaning solution.

## Moisture Purge Cycle

By its very nature, any HVAC unit with a cooling coil serves as a dehumidifier, reducing the surrounding air's ability to hold water vapor as its temperature falls. This normally doesn't present a problem when the unit is running.

However, when the fan stops, water vapor condenses on the cold metal surfaces inside the air handler and remains there until the air warms sufficiently to re-evaporate it. This damp, dark environment—though temporary—can encourage the growth of mold, mildew, and other microbial contaminants.

Providing a moisture purge cycle 15 to 30 minutes after shutdown disperses the cold, humid air inside the air-handling system more evenly throughout the building. This four-step cycle:

- Closes the outdoor air dampers.
- Turns off the cooling coil.
- Opens any variable-air-volume terminals connected to the air handler.
- Operates the supply fan for 10 to 15 minutes.

Air movement discourages water condensation and hastens re-evaporation of any condensate that does happen to form. This simple preventative measure effectively combats microbial growth and curbs moisture-related deterioration of air-handling components.

## Cleaning Non-Porous Surfaces

### **⚠ WARNING**

#### **Hazardous Voltage!**

**Failure to disconnect power before servicing could result in death or serious injury.**

**Disconnect all electric power, including remote disconnects before servicing. Follow proper lockout/tagout procedures to ensure the power can not be inadvertently energized. Verify that no power is present with a voltmeter.**

If microbial growth on a non-porous insulating surface (closed cell insulation or sheet metal surface) is observed:

1. Disconnect all electrical power to the unit.
2. Wearing the appropriate personal protective equipment, use a brush for sheet metal surfaces or a soft sponge on a foil face or closed cell foam surface to mechanically remove the microbial growth.

**Note:** *Be careful not to damage the non-porous surface of the insulation.*
3. Install a block-off to prevent spray from going into a dry section of the unit and/or system ductwork.
4. Thoroughly clean the contaminated area(s) with an EPA-approved sanitizer specifically designed for HVAC use.
5. Rinse the affected surfaces thoroughly with fresh water and a fresh sponge to prevent potential corrosion of the drain pan and drain line
6. Repeat [Step 4](#) and [Step 5](#) as necessary.
7. Confirm the drain line is open following the cleaning process.

8. Allow the unit to dry thoroughly before putting it back into service.
9. Replace all panels and parts and restore electrical power to the unit.
10. Be careful any contaminated material does not contact other areas of the unit or building. Properly dispose of all contaminated materials and cleaning solution

## Cleaning Porous Surfaces

### **⚠ WARNING**

#### **Hazardous Voltage!**

**Failure to disconnect power before servicing could result in death or serious injury.**

**Disconnect all electric power, including remote disconnects before servicing. Follow proper lockout/tagout procedures to ensure the power can not be inadvertently energized. Verify that no power is present with a voltmeter.**

To clean a porous insulating surface (fiberglass insulation):

1. Disconnect all electrical power to the unit.
2. Wearing the appropriate personal protective equipment, use a vacuum device with a HEPA filter (99.97 percent efficient at 0.3 micron particles) to remove the accumulated dirt and organic matter.  
**Note:** *Be careful not to tear the insulation surface or edges.*
3. Confirm the drain line is open following the cleaning process.
4. Allow the unit to dry thoroughly before putting it back into service.
5. Replace all panels and parts and restore electrical power to the unit.
6. Be careful any contaminated material does not contact other areas of the unit or building. Properly dispose of all contaminated materials and cleaning solution.



# Diagnostics and Troubleshooting

This section is intended to be used as a diagnostic aid only. For detailed repair procedures, contact your local Trane service representative.

**⚠ WARNING**

**Hazardous Service Procedures!**

Failure to follow all precautions in this manual and on the tags, stickers, and labels could result in death or serious injury.

Technicians, in order to protect themselves from potential electrical, mechanical, and chemical hazards, **MUST** follow precautions in this manual and on the tags, stickers, and labels, as well as the following instructions: Unless specified otherwise, disconnect all electrical power including remote disconnect and discharge all energy storing devices such as capacitors before servicing. Follow proper lockout/tagout procedures to ensure the power can not be inadvertently energized. When necessary to work with live electrical components, have a qualified licensed electrician or other individual who has been trained in handling live electrical components perform these tasks.

**Table 28. Troubleshooting recommendations**

| Symptom  | Heat | Cool | Probably Cause   | Recommended Action   |
|--|------|------|--|--|
| Room too warm (outside air temperature is below 35°F)  | X    |      | Main power off.  | Check fuses.   |
|  | X    |      | Room sensor is not properly set.   | Reset room sensor temperature.   |
|  | X    |      | Room sensor is providing a false reading due to walls being cold from the night temperature setting. | Start the warm-up cycle earlier in the morning to provide appropriate time-frame to increase room temperature prior to space occupation.   |
|  | X    |      | Sensor is mounted on a block wall that is leaking cold air into the room through the mounting holes. | Relocate sensor.   |
| Room too warm (outside air temperature is above 35°F)  | X    |      | Face-and-bypass damper, or coil valve is malfunctioning.   | Replace malfunctioning component, or contact the control's contractor, or if Trane controls, see CNT-SVX04*-EN for more information concerning Tracer® controls.   |
|  | X    |      | Room sensor is not properly set.   | Reset room sensor temperature.   |
|  | X    |      | Face-and-bypass damper or coil control valve is malfunctioning.                                      | Replace malfunctioning component, or contact the control's contractor, or if Trane controls, see CNT-SVX04*-EN for more information concerning Tracer® controls.   |
|  | X    |      | OA damper is in the closed position.   | Ensure OA damper is in the open position.  |
| Room too warm (outside air temperature is above 35°F)<br>Unit utilizes Wall Fin auxiliary radiation: | X    |      | Clogged filter.  | Replace filter.  |
|  | X    |      | Control valve is malfunctioning.   | Check flow of hot water through the control valve.   |
|  | X    |      | Boiler.  | Check the boiler reset schedule to determine if the loop temperature can be decreased.   |
|  | X    |      | Steam.   | Check the operation of the control valves.   |
|  | X    |      | Outside air temperature is above 60°F to 65°F.   | The economics of the unit ventilator selection dictate that, in most cases, the unit will be sized to provide adequate natural (ventilation) cooling without outside temperatures up to 60°F to 65°F. Above this point, a changeover should be made to the mechanical cooling cycle. |

**Table 28. Troubleshooting recommendations (continued)**

| Symptom  | Heat | Cool | Probably Cause   | Recommended Action   |
|--|------|------|--|--|
| Room too cool  |      | X    | Room sensor is not properly set.   | Reset room sensor temperature.   |
|  |      | X    | Clogged filter.  | Replace filter.  |
|  |      | X    | Face-and-bypass damper, or coil valve is malfunctioning.                           | Replace malfunctioning component, or contact control's contractor.   |
|  |      | X    | OA damper is in the open position.   | Ensure OA damper is in the closed or minimum outside air position.   |
|  |      | X    | Boiler pressure or temperature design requirements not being met.                  | On hot water and steam type units, check the boiler pressure or temperature to ensure that the requirements are being met.                                       |
| Room too cool<br>Unit utilizes Wall Fin auxiliary radiation: |      | X    | Radiation controls malfunctioning.   | Check the operation of the wall fin controls.  |
| Room too hot   |      | X    | Room sensor is not properly set.   | Reset room sensor temperature.   |
|  |      | X    | Clogged filter.  | Replace filter.  |
|  |      | X    | Face and bypass damper, or coil valve is malfunctioning.                           | Replace malfunctioning component, or contact the control's contractor, or if Trane controls, see CNT-SVX04*-EN for more information concerning Tracer® controls. |
|  |      | X    | OA damper is in the open position.   | Ensure OA damper is in the minimum outside air position.   |
|  |      | X    | Chiller temperature design requirements not being met.                             | Check the temperature of the water leaving the chiller to ensure that it meets design requirements.  |
| Motor  |      | X    | If the motor fails to start, and other motors on the same circuit are functioning. | Check the unit switch to ensure it is in the ON position.  |
|  |      | X    | If the motor fails to start, and other motors on the same circuit are functioning. | Check for loose switch or motor connection.  |
| 265 and 460 volt unit  | X    | X    | If the unit fails to start.  | Check fuse in right-hand end pocket inside the transformer mounting box. Replace with Trane fuse X1311057435 (ABC type 6A 250V).                                 |

## Wireless Zone Sensors (WZS)

The receiver for all models has four LEDs: LED1, LED2, LED3, and LED5. Locations are shown in the following figure.

**Note:** To view LEDs on a flush mount receiver on a fan coil unit, the front panel of the unit must be removed.

**Figure 78. Receiver for all fan coil models showing LED locations**

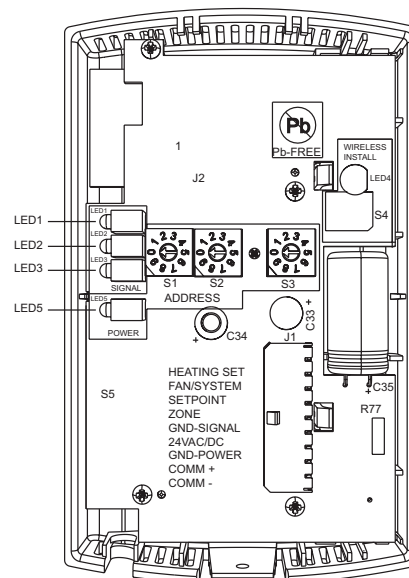

## Diagnostics and Troubleshooting

The sensor for a wireless zone sensor (WZS) has four LEDs: LED1, LED2, LED3, and LED5 and a test button. Locations are shown in the following figure.

**Figure 79. WZS showing LED locations and test button**

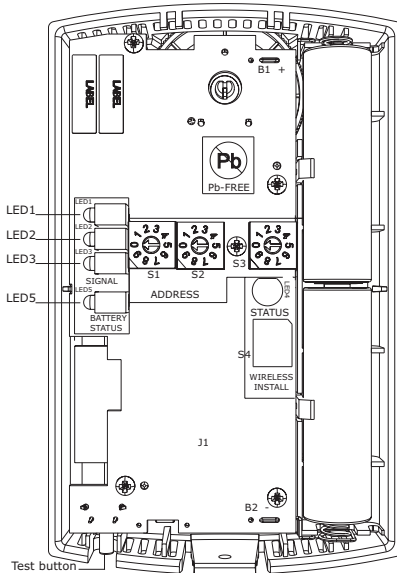

The sensor for a wireless display sensor (WDS) has test symbols and error codes that appear on the display, and a test button. Locations are shown in the following figure.

**Figure 80. Wireless display sensor (WDS) shows test symbols and error codes**

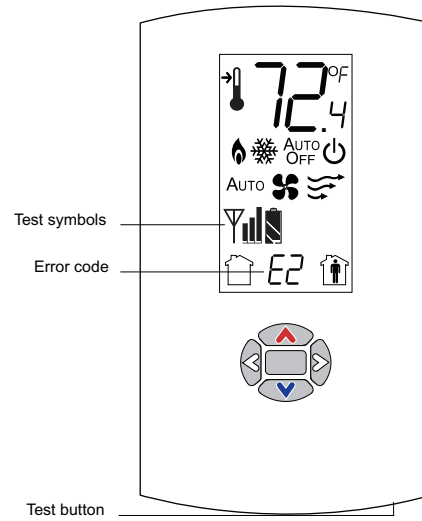

### Receiver Diagnostics

LED1, LED2, and LED3, located on the receiver of all models respond to diagnostics by exhibiting specific blinking patterns. They respond independently of any user action.

**Table 29. Diagnostics on the receiver**

| LED state  | Indicates...   |
|--|--|
| LED1: Off<br>LED2: Off<br>LED3: 1-blink pattern repeated continuously <sup>(a)</sup> | Disassociated<br>Receiver is not associated, waiting for a sensor.<br>Receiver lost communication with sensor.<br>Receiver has no devices on its wireless personal area network.<br>Association with a device has been manually removed. |
| LED1: Off<br>LED2: Off<br>LED3: 2-blink pattern repeated continuously <sup>(a)</sup> | Address set to 000.<br>Address not set to between 001–999.   |
| LED1: Off<br>LED2: Off<br>LED3: 3-blink pattern repeated continuously <sup>(a)</sup> | Not configured.<br>Receiver configuration properties not properly set (defective receiver).  |

<sup>(a)</sup> Blink pattern is On for 1/4 s, Off for 1/4 s, with 2 s Off between repetitions.

### Sensor Diagnostics

LED1, LED2, and LED3, located on the WZS respond to diagnostics by exhibiting specific blinking patterns. View

their response by pressing the Test button. Error codes appear on the WDS when diagnostics occur.

**Table 30. Diagnostics for wireless zone sensors and error code shown on wireless display sensor**

| LED state when Test button is pressed on WZS                                     | Error code shown on WDS | Indicates...   |
|--|-------------------------|--|
| n/a  | E0, E5, E7              | Sensor failure<br>Replace sensor                           |
| LED1: Off<br>LED2: Off<br>LED3 <sup>(a)</sup> : 1-blink pattern repeated 3 times | E1                      | Disassociated<br>Sensor is not associated with a receiver. |

**Table 30. Diagnostics for wireless zone sensors and error code shown on wireless display sensor (continued)**

| LED state when Test button is pressed on WZS                                     | Error code shown on WDS | Indicates...  |
|--|-------------------------|---|
| LED1: Off<br>LED2: Off<br>LED3 <sup>(a)</sup> : 2-blink pattern repeated 3 times | E2                      | Address set to 000<br>Address not set to between 001–999.   |
| LED1: Off<br>LED2: Off<br>LED3 <sup>(a)</sup> : 3-blink pattern repeated 3 times | E3                      | Software error<br>Replace sensor  |
| LED1: Off<br>LED2: Off<br>LED3 <sup>(a)</sup> : 4-blink pattern repeated 3 times | E4                      | Input voltage too high<br>No RF transmission is permitted with an input battery voltage greater than 3.9 V. |

<sup>(a)</sup> Blink pattern is On for 1/4 s, Off for 1/4 s, with 2 s Off between repetitions.

### Testing Signal Strength





To initiate a signal strength test, push the Test button on the sensor (see location of Test button in [Figure 79, p. 96](#) and [Figure 80, p. 96](#)).

- **Models WZS:** LED1, LED2, and LED3 respond by indicating signal strength. You can view them on the

sensor ([Table 31, p. 97](#)) and the receiver ([Table 32, p. 98](#)).

- **Model WDS:** Test symbols on the sensor display indicate signal strength ([Table 31, p. 97](#)). LED1, LED2, and LED3, on the receiver, respond by indicating signal strength ([Table 32, p. 98](#)).

**Table 31. Observing signal strength on the wireless zone sensor**

| User action                     | LED state   | Symbol displayed on WDS   | Indicates...   |
|---------------------------------|---|---|--|
| None                            | LED1: Off<br>LED2: Off<br>LED3: Off   | No Test symbols appear  | Normal state<br>No Test button press.  |
| Press Test button on the sensor | LED1: Off<br>LED2: Off<br>LED3: Off   |  | Associated; no communication with receiver<br>Associated, but no signal from the receiver after pressing Test button.  |
|                                 | LED1: On<br>LED2: On<br>LED3: On<br>Displays for 5 seconds, then constantly Off   |  | Excellent signal strength<br>Good signal margin for reliable communication.  |
|                                 | LED1: Off<br>LED2: On<br>LED3: On<br>Displays for 5 seconds, then constantly Off  |  | Satisfactory signal strength<br>Adequate signal strength for reliable communication.<br>Moving sensor or receiver may improve signal strength.<br>Increased channel switching may reduce battery life. |
|                                 | LED1: Off<br>LED2: Off<br>LED3: On<br>Displays for 5 seconds, then constantly Off |  | Poor signal strength<br>Unreliable communication.<br>Strongly recommend moving the sensor or receiver to a better location.  |

## Diagnostics and Troubleshooting

**Table 32. Observing signal strength on the receiver**

| User action                     | LED state on receiver   | Indicates...   |
|---------------------------------|---|--|
| None                            | LED1: Off<br>LED2: Off<br>LED3: Off   | Normal state<br>No Test button press.  |
| Press Test button on the sensor | LED1: On<br>LED2: On<br>LED3: On<br>Displays for 5 seconds, then constantly Off   | Excellent signal strength<br>Good signal margin for reliable communication.  |
|                                 | LED1: Off<br>LED2: On<br>LED3: On<br>Displays for 5 seconds, then constantly Off  | Satisfactory signal strength<br>Adequate signal strength for reliable communication.<br>Moving sensor or receiver may improve signal strength.<br>Increased channel switching may reduce battery life. |
|                                 | LED1: Off<br>LED2: Off<br>LED3: On<br>Displays for 5 seconds, then constantly Off | Poor signal strength<br>Unreliable communication<br>Strongly recommend moving the sensor or receiver to a better location  |

### Testing Battery Status

Initiate a battery status test as follows:



- On the WZS, push the Test button on the sensor (see location on [Figure 79, p. 96](#)). LED5 on the sensor responds by indicating the level of battery strength, as shown in [Table 33, p. 98](#).
- On the WDS, push the Test button on the sensor (see location on [Figure 80, p. 96](#)). In response, a battery test symbol appears on the display. The symbol shown indicates battery life expectancy (see [Table 34, p. 98](#)).

**Table 33. Battery status indicated by LED5 on the wireless zone sensors**

| User action       | LED state  | Indicates...  |
|-------------------|--|---|
| Press Test button | Solid green for 5 seconds  | Battery is adequate for proper operation.   |
|                   | Solid red for 5 seconds  | 25% battery life left. Batteries should be replaced.  |
|                   | No light   | Batteries life expired or not installed properly, or sensor is defective.                     |
| None              | Blinking red: 1-blink pattern <sup>(a)</sup> repeated 5 times. Cycle repeats every 15 minutes. | Approximately 14 days of operation remain before the battery is too weak to power the sensor. |

<sup>(a)</sup> Blink pattern is On for 1/4 s, Off for 3/4 s, with 2 s Off between repetitions.

**Table 34. Battery status shown on the wireless display sensor**

| User action       | Battery test symbol   | Indicates...        | Battery test symbol   | Indicates...                  | Battery test symbol   | Indicates...  |
|-------------------|---|---------------------|---|-------------------------------|---|---|
| Press Test button |  | Full battery power. |  | 50 percent battery life left. |  | 25 percent battery life left. Replace batteries. Flashing symbol indicates that approximately 14 days of operation remain before the battery is too weak to power the sensor. |

### 24 V Power Status Indicator

LED5 on the receiver of all models (see [Figure 78, p. 95](#)) lights and stays constantly On when 24 V power is normal.

### Check Signal Strength on a Site

Use the wireless sensor system to check the signal strength on a site.

- Power up a receiver with a 24 V transformer (user supplied).
- Associate the sensor to a receiver of the same model intended for the job.
- Place the receiver at the desired location.
- Place or hold the sensor at the desired location.

- Press the Test button (S5) on the sensor and observe the signal strength as indicated by LED1, LED2, and LED3 on model WZS (see [Figure 79, p. 96](#)), and on the display on model WDS (see [Figure 80, p. 96](#)).

For more information on interpreting the LEDs and the display symbols that indicate signal strength, see “[Testing Signal Strength](#),” p. 97.

### Replacing Sensor Batteries

Sensor battery type, length of life, and installation are addressed in this section.

#### Battery Type

#### NOTICE

##### Battery Damage!

Failure to follow instructions below could result in battery leakage and, in some cases, cause the safety release vent to open.

**Do NOT attempt to recharge the batteries. The batteries are manufactured in a ready-to-use state and are NOT designed for recharging.**

#### NOTICE

##### Sensor Damage!

**Do not hook up the sensor to a power supply as it could result in sensor damage.**

Use two non-rechargeable 1.5 V lithium AA batteries in the sensor. To maintain UL rating, use only UL-listed lithium batteries. The sensor ships with Energizer® L91 batteries already installed. Replacement batteries are available at Trane Service Parts Centers (Part number: X13770035010) or other local suppliers.

#### Battery Life

Battery life is five years under normal conditions. If the sensor is not used for an extended period of time, do one of the following:

- Set the sensor address to 000 to place the sensor into a low-power hibernation mode.
- Remove the batteries.

#### Notes:

- If lithium batteries are temporarily unavailable, alkaline batteries can be used. However, alkaline battery life is very short by comparison.*
- The battery life for model WDS may decrease with extended LCD display activity.*

### Battery Installation

#### ⚠ WARNING

##### Risk of Injury with Batteries!

Failure to follow handling instructions below could result in severe injury.

- Do NOT install batteries backwards.**
- Do NOT disassemble, charge, or expose batteries to water, fire, or high temperature.**
- Keep batteries away from children. If swallowed, contact your local poison control center immediately.**

- Observe the polarity indicators that are molded into the cover.
- Install two batteries (of the type specified in “[Battery Type](#),” p. 99) in the battery-holding slot that is molded into the sensor cover.

The sensor has been designed to prevent damage if the batteries are installed backwards, to reduce the potential for injury.

### Manual Association

Before attempting manual or automatic association, the receiver must indicate readiness to associate (one blink pattern of LED3 on receiver). Refer to “[Observing the Receiver for Readiness to Associate](#),” p. 51.

At any time, the manual association method can be used to associate the receiver with the sensor. If an association was previously established between a receiver and a sensor and needs to be re-established, the manual association process may be used. If an association has not yet been established, the automatic association process is recommended (see “[Associating the Sensor to the Receiver](#),” p. 51).

- Using a small screwdriver, set the three rotary address switches ([Figure 49, p. 51](#), locations S1, S2, S3) on the receiver to an address between 001 and 999.

**Note:** *An address can be changed at any time after initial association has been established. It is not necessary to power down the receiver or sensor.*

- Set the three rotary address switches ([Figure 49, p. 51](#), locations S1, S2, S3) on the sensor to the same address as the receiver.
- Record the address and location of the receiver and sensor pair.
- After verifying that the receiver and sensor are powered up, press the Test button on the sensor to establish that the signal strength (“[Testing Signal Strength](#),” p. 97) and the battery life (“[Testing Battery Status](#),” p. 98) are adequate for proper functioning.

### Disassociation

The receiver disassociates from the sensor (by removing all stored association information), conducts a channel scan, and restarts itself, if any of the following are true:

- The receiver address is changed from its current setting (001–999).
- The receiver receives a disassociation notification from its associated sensor.
- The receiver does not receive a communication from its associated sensor within 50 minutes.
- The sensor and receiver are associated and communicating at the time the sensor is set to 000 and the Test button is pressed.

**Note:** A disassociated sensor will transit an association request every 10 minutes.

### Sensor/Receiver Compatibility

Version 1.5 (part number: X13790854 and X13790855) and higher receivers are compatible with all sensors models and support all functions. Receivers released prior to version 1.5 are compatible with only model WZS.

### Replacing a Failed Sensor or Receiver

**Note:** Receivers ship installed on the unit. To remove the receiver, press in the retention tabs on the underside of the receiver enclosure and push upward.

To replace a failed sensor or receiver:

1. Confirm that the device is disassociated (see [Table 29, p. 96](#) and [Table 30, p. 96](#)).
2. Set the rotary address switch of the new device to match the address of the remaining sensor or receiver.

**Note:** There is no need to remove power from the remaining device.

3. Apply power to the new device. Association between the new and the remaining devices will automatically occur.

**Note:** When replacing a WDS sensor, the receiver (version 1.5 or higher) will automatically configure the sensor to match the last stored configuration, if the sensor has not been placed into configuration mode and the factory default configuration is still valid. If the sensor configuration does not match the desired system features, it can be manually configured (see [“Manual Association,” p. 99](#)).

### Servicing and Testing WZS

If the wireless sensor system is not working as expected, use the tools and procedure described in this section.

#### Servicing and Testing Tools

No special tools or software are necessary to service and test the wireless sensor system. Test the system by using:

- The LEDs on the receiver, LEDs on the model WZS sensor, and the display on the model WDS sensor
- The Test button on the sensor
- The address test mode on the receiver
- A common volt-ohm meter

### Procedure for Testing Zone Sensor

If the wireless zone sensor is not working as expected:

1. Observe LED5 on the receiver. LED5 is On solid green whenever the receiver is powered.
2. Verify that the receiver is properly grounded. Both the GND-SIGNAL (black) wire and the GND-POWER (yellow) wire must be grounded.
3. Press the Test button on the sensor.

- Model WZS: LED5 should turn On solid green, indicating proper battery strength. LED1, LED2, and LED3 will indicate signal strength.

**Note:** When checking signal strength, both LED1 and LED3 on the receiver and sensor illuminate in unison if the sensor and receiver are associated. Use this feature to confirm association.

- Model WDS: Battery life and signal strength (“Testing Signal Strength,” [p. 97](#) and “Testing Battery Status,” [p. 98](#)) are indicated on the display.

### Procedure for Testing Receiver

If the receiver is not working as expected:

1. Verify that the receiver is powered.
2. Set the receiver address to 000 to force the zone temperature output and zone temperature setpoint output to their default mode values (see [“Failure and Default Modes,” p. 101](#)).
3. Measure the receiver output resistance (see [“Measuring Output Resistance,” p. 101](#)).
4. When the test is complete, reset the receiver address to its previous setting.
5. Press the Test button on the sensor to force re-association.
6. Confirm association and communication by noting LED1, LED2, and LED3 as described in [“Testing Signal Strength,” p. 97](#).

### Forcing a Sensor to Transmit

To force a wireless sensor to transmit during servicing, press the Test button on the sensor.

### Output Power Level

The maximum output power level of a wireless sensor set is controlled by software and restricted by channel of operation and agency requirements per country or region. The sensor has a default maximum power level of 10 mW,

but the receiver determines the ultimate output power level of the sensor.

### Failure and Default Modes

The following table provides output values for failure and default modes of operation, which can be used for troubleshooting.

**Table 35. Output values - failure and default modes of operation**

| Situation   | Zone temperature output                                  | Zone setpoint output                                   | Heating setpoint output              | Fan/System output                    |
|---|--|--|--------------------------------------|--------------------------------------|
| Receiver address = 000  | 11.17 kΩ, 72.5°F (22.5°C), indefinitely                  | 451 Ω, 72.5°F (22.5°C), indefinitely                   | 501 Ω, 70.5°F (21.4°C), indefinitely | 2320 Ω<br>Fan = Auto<br>System = Off |
| Receiver address = 001 to 999 and:<br>Receiver is powered up, but not is associated, or<br>Receiver has received a disassociation request from the associated sensor. | 11.17 kΩ, 72.5°F (22.5°C) Hold for 15 minutes, then open | 451 Ω, 72.5°F (22.5°C), Hold for 15 minutes, then open | 501 Ω, 70.5°F (21.4°C), indefinitely | 2320 Ω<br>Fan = Auto<br>System = Off |
| Receiver address = 001 to 999 and receiver has not received a communication within 35 minutes from the associated sensor.   | Open   | Open   | Open                                 | Open                                 |
| Receiver has no power.  | Open   | Open   | Open                                 | Open                                 |
| Thermistor in sensor has failed to either open or close.  | Open   | Normal value   | Normal value                         | n/a                                  |
| Setpoint potentiometer has failed to either open or close.  | Normal value   | Open   | Open                                 | n/a                                  |

### Measuring Output Resistance

To measure the resistance of receiver outputs for zone temperature and setpoints for all models, and heating setpoint and fan/system for the WDS:

1. Ensure that the GND-SIGNAL (black) wire and the GND-POWER (yellow) wire are grounded to the transformer.
2. Disconnect the ZONE (white) and SETPOINT (RED) wires from the controller. Disconnect the HEAT SETPOINT (brown) and FAN/SYSTEM (green) wires from the controller, if applicable.
3. Measure resistance as follows:
  - All models: Measure between the grounded GND-SIGNAL (black) wire and either the SETPOINT (red) or ZONE (white) wire. Compare resistance measurements to those in [Table 36, p. 101](#).

**Table 36. Receiver resistance table for all models**

| Zone or setpoint temperature | Nominal zone temperature output resistance | Nominal setpoint/heating setpoint output resistance |
|------------------------------|--|---|
| 55°F (12.8°C)                | 17.47 kΩ                                   | 792 Ω   |
| 60°F (15.6°C)                | 15.3 kΩ                                    | 695 Ω   |
| 65°F (18.3°C)                | 13.49 kΩ                                   | 597 Ω   |

**Table 36. Receiver resistance table for all models (continued)**

| Zone or setpoint temperature | Nominal zone temperature output resistance | Nominal setpoint/heating setpoint output resistance |
|------------------------------|--|---|
| 70°F (21.1°C)                | 11.9 kΩ                                    | 500 Ω   |
| 75°F (23.9°C)                | 10.5 kΩ                                    | 403 Ω   |
| 80°F (26.7°C)                | 9.3 kΩ                                     | 305 Ω   |
| 85°F (29.4°C)                | 8.25 kΩ                                    | 208 Ω   |

- WDS only: Measure between the grounded GND-SIGNAL (black) wire and the FAN/SYSTEM (green) wire.

## Symbio™ 400-B Controller

### LED Activity

There are 15 LEDs on the front of the Symbio™ 400-B controller. The following table provides a description of LED activity, an indication or troubleshooting tip for each, and any related notes.

## Diagnostics and Troubleshooting

**Table 37. LED activity and troubleshooting tips for Symbio™ 400-B controller**

| LED Name               | Activities  | Indication and Troubleshooting Tips   | Notes  |
|------------------------|---|---|--|
| Marquee LED            | Shows solid green when the unit is powered and no alarm exists                              | Indicates normal operation  | When powering the Symbio™ 400-B and expansion module, the Marquee LED will blink <b>RED</b> , blink <b>GREEN</b> (indicating activated and controller/expansion module are communicating), and then stay <b>GREEN CONTINUOUSLY</b> (indicating normal power operation).  |
|                        | Shows blinking green during a device reset or firmware download                             | Indicates normal operation  |  |
|                        | Shows solid red when the unit is <b>powered</b> , but represents low power or a malfunction | <b>If low power</b> ; could be under voltage or the microprocessor has malfunction. Measure for the expected value range. For more information, refer to <i>Symbio™ 400-B Programmable Controller Installation, Operation, and Maintenance</i> (BAS-SVX093*-EN). <b>If malfunction</b> ; un-power and then re-power unit to bring the unit back up to normal operation. |  |
|                        | Shows blinking red when an <b>alarm</b> or fault exists                                     | An alarm or fault condition will occur if the value for a given point is invalid or outside the configured limits for the point. Alarm and fault conditions vary, and they can be configured by the programmer.   |  |
|                        | LED not lit   | Indicates power is OFF or there is a malfunction <b>OFF</b> or <b>malfunction</b> ; cycle the power. For more information, refer to <i>Symbio™ 400-B Programmable Controller Installation, Operation, and Maintenance</i> (BAS-SVX093*-EN).   |  |
| Link and IMC           | TX blinks green   | Blinks at the data transfer rate when the unit transfers data to other devices on the link  | TX LED: Regardless of connectivity or not, this LED will constantly blink as it continually looks for devices to communicate to.<br>LED not lit:<br>Determine if, for example, a Tracer® SC or BACnet® device is trying to talk to the controller or if it is capable of talking to the controller. Also determine if the communication status shows down all of the time. In addition, check polarity and baud rate.<br>For more information, refer to <i>Symbio™ 400-B Programmable Controller Installation, Operation, and Maintenance</i> (BAS-SVX093*-EN).  |
|                        | RX blinks yellow  | Blinks at the data transfer rate when the unit receives data from other devices on the link<br><b>ON solid yellow</b> ; indicates there is reverse polarity   |  |
|                        | LED is not lit  | Indicates that the controller is not detecting communication<br><b>Not lit</b> ; cycle the power to reestablish communication   |  |
| Service                | Shows solid green when the LED has been pressed   |   | When the Symbio™ 400-B is placed into boot mode, the system will not run any applications such as trending, scheduling, and TGP2 runtime. The controller will be placed into boot mode if the service pin is held in when power is applied. In boot mode, the controller is non-operational and is waiting for a new main application to be downloaded.  |
|                        | LED not lit   | Indicates controller is operating normally  |  |
| Binary B01 through B09 | Shows solid yellow  | Indicates a corresponding binary output has been <b>commanded ON Relay coil</b> ; indicates that a command has been made to energize <b>TRIAC</b> ; indicates that a command has been made to turn ON   | If the user is currently powering the Symbio™ 400-B from a USB port, the Led lights will turn <b>ON</b> . However, the binary outputs <u>will not</u> be activated.<br><b>Commanded ON</b> ; As an example of commanded ON, a command could be a manual command such as an override or a command could be from TGP2 based on a list of conditions that are met telling these outputs to turn ON.<br>LED not lit:<br>Did the user command it to be ON? If yes, see the Marquee LED at the top of this table. For more information, refer to <i>Symbio™ 400-B Programmable Controller Installation, Operation, and Maintenance</i> (BAS-SVX093*-EN). |
|                        | LED not lit   | Indicates that a relay output is de-energized or no power to the board<br><b>Not lit</b> ; cycle power to reestablish communication   |  |

### Overriding Outputs

Analog and multistate value request points are included in order to safely override outputs without disrupting TGP2 program operation. To override valves and dampers for commissioning or testing purposes, access the following points on the Tracer® TU analog or multistate status pages:

- Cool valve request
- DX cool request
- Heat valve request
- Electric heat request
- Economizer request
- Supply fan speed active

For more information, refer to *Symbio™ 400-B Programmable Controller Installation, Operation, and Maintenance* (BAS-SVX093\*-EN).

### Diagnostics

Diagnostics are informational messages that indicate the operational status of the controller. In response to most diagnostics, the controller attempts to protect the equipment by enabling/disabling, or by opening/closing specific outputs. Other diagnostics provide information about the status of the controller, but have no effect on outputs. Diagnostics are reported in the order in which they occur. Multiple diagnostics can be present simultaneously. Diagnostic messages are viewed using the Tracer® TU service tool or through a BAS.

**Note:** *Tracer® TU will report only active diagnostics.*

### Diagnostics Types

Diagnostics are categorized according to the type of clearing method each uses and the type of information each provides.

The diagnostic types are:

- Manual (latching) diagnostics
- Automatic (non-latching) diagnostics
- Smart reset diagnostics
- Informational diagnostics

**Note:** *Clearing diagnostics refers to deleting diagnostics from the software; it does not affect the problem that generated the message.*

### Manual (Latching) Diagnostics

Manual diagnostics (also referred to as latching) cause the unit to shutdown. Manual diagnostics can be cleared from the Symbio™ 400-B controller in one of the following ways:

- By using the Tracer® TU service tool to reset latching diagnostics on the **Alarms Status** tab or by temporarily overriding the **Reset Diagnostic Request** (bv/2) on the **Binary Status** tab.
- Through a building automation system.
- By cycling power to the controller. When the 24Vac power to the controller is cycled **OFF** and then **ON** again, a power-up sequence occurs.

### Automatic (Non-latching) Diagnostics

Automatic diagnostics clear automatically when the problem that generated the diagnostic is solved.

### Smart Reset Diagnostics

Smart Reset Diagnostics are latching diagnostics that will auto-recover if the condition is corrected. After the controller detects the first smart reset diagnostic, the unit waits 30 minutes before initiating the smart reset function. If another diagnostic of this type occurs again within 24 hours after an automatic clearing, clear the diagnostic manually by using any of the ways listed in [“Manual \(Latching\) Diagnostics,” p. 103](#).

### Informational Diagnostics

Informational diagnostics provide information about the status of the controller. They *do not* affect machine operation, but can be cleared from the controller using the BAS or Tracer® SC.

### Building Automation System

Some building automation systems can reset diagnostics in the controller. For more complete information, refer to the product literature for the building automation system.

### Trane Service Tools

Tracer® TU can be used to reset diagnostics present in a Symbio™ 400-B controller.

### Controller Diagnostics

[Table 38, p. 104](#) lists each diagnostic that can be generated by the Symbio™ 400-B controller, the diagnostic effect on outputs (consequences), and diagnostic type.

**Note:** *The generic binary output is unaffected by diagnostics.*

## Diagnostics and Troubleshooting

**Table 38. Diagnostics generated by Symbio™ 400-B controller**

| Diagnostic                                | Probable Cause  | Consequences  | Diagnostic Type    |
|---|---|---|--------------------|
| Filter change required                    | Fan run hours exceed the time set to indicate filter change.                        | <ul style="list-style-type: none"> <li>Fan <b>Unaffected</b></li> <li>Valves <b>Unaffected</b></li> <li>Electric heat <b>Unaffected</b></li> </ul>  | Informational      |
| Condensate overflow                       | The drain pan is full of water.   | <ul style="list-style-type: none"> <li>Fan <b>OFF</b></li> <li>Valves <b>Closed</b></li> <li>Outdoor air damper <b>Closed</b></li> <li>DX/electric heat <b>OFF</b></li> </ul>                                     | Manual             |
| Low coil temp detection                   | The leaving fluid temperature may be close to freezing.                             | <ul style="list-style-type: none"> <li>Fan <b>OFF</b></li> <li>Valves <b>Open</b></li> <li>Outdoor air damper <b>Closed</b></li> <li>DX/electric heat <b>OFF</b></li> </ul>                                       | Smart reset/Manual |
| Low airflow supply fan failure            | The fan drive belt, contactor, or motor has failed.                                 | <ul style="list-style-type: none"> <li>Fan <b>OFF</b></li> <li>Valves <b>Closed</b></li> <li>Outdoor air damper <b>Closed</b></li> <li>DX/electric heat <b>OFF</b></li> </ul>                                     | Manual             |
| Space temperature failure <sup>(a)</sup>  | Invalid or missing value for zone temperature.                                      | <ul style="list-style-type: none"> <li>Discharge air temperature control runs</li> <li>Unit shuts <b>OFF</b> if both space temperature and discharge air temperature fail</li> </ul>                              | Automatic          |
| Entering water temp failure               | Invalid or missing value for zone temperature.                                      | <ul style="list-style-type: none"> <li>Fan <b>Unaffected</b> (enabled)</li> <li>Valves <b>Unaffected</b></li> <li>Outdoor air damper <b>Unaffected</b></li> <li>DX/electric heat <b>Unaffected</b></li> </ul>     | Automatic          |
| Discharge air temp low limit              | Discharge air temperature has fallen below the Discharge Air Temperature Low Limit. | <ul style="list-style-type: none"> <li>Fan <b>OFF</b></li> <li>Valves <b>Open</b></li> <li>Outdoor air damper <b>Closed</b></li> <li>DX/electric heat <b>OFF</b></li> </ul>                                       | Smart reset/manual |
| Discharge air temp failure <sup>(a)</sup> | Invalid or missing value for discharge air temperature.                             | <ul style="list-style-type: none"> <li>Simplified zone control algorithm runs</li> <li>Unit shuts <b>OFF</b> if zone temperature fails</li> </ul>   | Automatic          |
| Outdoor air temp failure                  | Invalid or missing value for outdoor air temperature.                               | <ul style="list-style-type: none"> <li>Fan <b>Unaffected</b></li> <li>Valved <b>Unaffected</b></li> <li>Outdoor air damper <b>Minimum Position</b></li> <li>DX cooling/electric heat <b>Unaffected</b></li> </ul> | Automatic          |
| Humidity input failure                    | Invalid or missing value for relative humidity.                                     | <ul style="list-style-type: none"> <li>Fan <b>Unaffected</b></li> <li>Valves <b>Unaffected</b></li> <li>Outdoor air damper <b>Unaffected</b></li> <li>DX cooling/electric heat <b>Unaffected</b></li> </ul>       | Automatic          |
| CO <sub>2</sub> sensor failure            | Invalid or missing value for CO <sub>2</sub> .                                      | <ul style="list-style-type: none"> <li>Fan <b>Unaffected</b></li> <li>Valves <b>Unaffected</b></li> <li>Outdoor air damper <b>Unaffected</b></li> <li>DX cooling/electric heat <b>Unaffected</b></li> </ul>       | Informational      |

**Table 38. Diagnostics generated by Symbio™ 400-B controller (continued)**

| Diagnostic             | Probable Cause   | Consequences  | Diagnostic Type |
|------------------------|--|---|-----------------|
| Generic AIP failure    | Invalid or missing value for generic analog input.   | <ul style="list-style-type: none"> <li>Fan <b>Unaffected</b></li> <li>Valves <b>Unaffected</b></li> <li>Outdoor air damper <b>Unaffected</b></li> <li>DX cooling/electric heat <b>Unaffected</b></li> </ul> | Informational   |
| Local fan mode failure | Invalid or missing fan-speed switch ( <i>reverts to default fan speed</i> ).                   | <ul style="list-style-type: none"> <li>Fan <b>Unaffected</b></li> <li>Valves <b>Unaffected</b></li> <li>Outdoor air damper <b>Unaffected</b></li> <li>DX cooling/electric heat <b>Unaffected</b></li> </ul> | Automatic       |
| Local setpoint failure | Invalid or missing value for zone temperature setpoint ( <i>reverts to default setpoint</i> ). | <ul style="list-style-type: none"> <li>Fan <b>Unaffected</b></li> <li>Valves <b>Unaffected</b></li> <li>Outdoor air damper <b>Unaffected</b></li> <li>DX cooling/electric heat <b>Unaffected</b></li> </ul> | Automatic       |

<sup>(a)</sup> For detailed information about zone temperature control methods, refer to [Zone Temperature Control](#), p. 81.

## Fans with Symbio™ 400-B Controller

**Table 39. Fan does not energize**

| Probable Cause                   | Explanation   |
|----------------------------------|---|
| Unit wiring                      | The wiring between the controller outputs and the fan relays and contacts must be present and correct for normal fan operation. Refer to applicable wiring diagram.   |
| Failed end device                | The fan motor and relay must be checked to ensure proper operation.   |
| Normal operation                 | <p>The fan will turn <b>OFF</b> when:</p> <ul style="list-style-type: none"> <li>The controller receives a communicated off signal.</li> <li>The fan-speed switch is set to <b>OFF</b> if no communicated value is present.</li> <li>Specific diagnostics are generated.</li> <li>The default fan speed is set to <b>OFF</b> and the fan is operating in the Auto mode.</li> </ul> <p>If the controller is in unoccupied mode, the fan cycles between <b>OFF</b> and the highest fan speed.</p> |
| No power to the controller       | If the controller does not have power, the unit fan does not operate. For the controller to operate normally, it must have an input voltage of 24 Vac. If the Marquee/Power LED is <b>OFF</b> continuously, the controller does not have sufficient power or has failed.  |
| Diagnostic present               | Several diagnostics affect fan operation. For detailed information about these diagnostics, refer to <a href="#">Table 38</a> , p. 104.   |
| Unit configuration               | The controller must be properly configured based on the actual installed end devices and application. If the unit configuration does not match the actual end device, the fans may not work correctly.  |
| Random start observed            | After power-up, the controller always observes a random start from 5 to 30 seconds. The controller remains <b>OFF</b> until the random start time expires.  |
| Cycling fan operation/continuous | The controller continuously operates the fan when in the occupied, occupied standby, or occupied bypass mode. When the controller is in the unoccupied mode, the fan is cycled between high speed and <b>OFF</b> with capacity.   |
| Unoccupied operation             | Even if the controller is configured for continuous fan operation, the fan normally cycles with capacity during unoccupied mode. While unoccupied, the fan cycles <b>ON</b> or <b>OFF</b> with heating/cooling to provide varying amounts of heating or cooling to the space.   |
| Fan mode off                     | If a local fan mode switch determines the fan operation, the <b>OFF</b> position controls the fan to off.   |
| Requested mode off               | The user can communicate a desired operating mode ( <i>such as OFF, heat, and cool</i> ) to the controller. If <b>OFF</b> is communicated to the controller, the unit controls the fan to off. There is no heating or cooling.  |



## Diagnostics and Troubleshooting

### Valves with Symbio™ 400-B Controller

**Table 40. Valves remain closed**

| Probable Cause                            | Explanation  |
|---|--|
| Unit wiring                               | The wiring between the controller outputs and the valve(s) must be present and correct for normal valve operation. Refer to applicable wiring diagram.   |
| Failed end device                         | The valves must be checked to ensure proper operation.   |
| No power to the controller                | If the controller does not have power, the unit valve(s) will not operate. For the controller to operate normally, apply an input voltage of 24 Vac. If the Marquee/Power LED is <b>OFF</b> continuously, the controller does not have sufficient power or has failed. |
| Diagnostic present                        | Several diagnostics affect valve operation. For detailed information about these diagnostics, refer to <a href="#">Table 38, p. 104</a> .  |
| Normal operation                          | The controller opens and closes the valves to meet the unit capacity requirements.   |
| Unit configuration                        | The controller must be properly configured based on the actual installed end devices and application. If the unit configuration does not match the actual end device, the valves may not work correctly.   |
| Random start observed                     | After power-up, the controller always observes a random start from 5 to 30 seconds. The controller remains <b>OFF</b> until the random start time expires.   |
| Requested mode off                        | The user can communicate a desired operating mode (such as <b>OFF</b> , heat, and cool) to the controller. If <b>OFF</b> is communicated to the controller, the unit controls the fan to off. There is no heating or cooling.  |
| Entering water temperature sampling logic | The controller includes entering water temperature sampling logic, which is automatically initiated during 2-pipe and 4-pipe changeover, if the entering water temperature is either too cool or too hot for the desired heating or cooling.                           |
| Valve configuration                       | Ensure the valves are correctly configured, using the Tracer® TU service tool, as normally open or normally closed as dictated by the application.   |

**Table 41. Valves remain open**

| Probable Cause                            | Explanation  |
|---|--|
| Unit wiring                               | The wiring between the controller Soutputs and the valve(s) must be present and correct for normal valve operation. Refer to applicable wiring diagram.  |
| Failed end device                         | The valves must be checked to ensure proper operations.  |
| Normal operation                          | The controller opens and closes the valves to meet the unit capacity requirements.   |
| Diagnostic present                        | Several diagnostics affect valve operation. For detailed information about these diagnostics, refer to <a href="#">Table 38, p. 104</a> .  |
| Unit configuration                        | The controller must be properly configured based on the actual installed end devices and application. If the unit configuration does not match the actual end device, the valves may not work correctly.   |
| Entering water temperature sampling logic | The controller includes entering water temperature sampling logic, which is automatically initiated during 2-pipe and 4-pipe changeover, if the entering water temperature is either too cool or too hot for the desired heating or cooling.   |
| Valve configuration                       | Ensure the valves are correctly configured, using the Tracer® TU service tool, as normally open (NO) or normally closed (NC) as dictated by the application.   |
| Freeze avoidance                          | When the fan is <b>OFF</b> with no demand for capacity (0%), and the outdoor air temperature is below the freeze avoidance setpoint, the controller opens the water valves (100%) to prevent coil freezing. This includes unoccupied mode when there is no call for capacity or any other time the fan is <b>OFF</b> . |

### DX Coils or Electric Heat with Symbio™ 400-B Controller

**Table 42. DX or electric heat does not energize**

| Probable Cause    | Explanation   |
|-------------------|---|
| Unit wiring       | The wiring between the controller outputs and the end devices must be present and correct for normal operation. Refer to applicable wiring diagram. |
| Failed end device | Check the control contactors or the electric heat element, including any auxiliary safety interlocks, to ensure proper operation.                   |

**Table 42. DX or electric heat does not energize (continued)**

| Probable Cause             | Explanation  |
|----------------------------|--|
| No power to the controller | If the controller does not have power, heat outputs do not operate. For the controller to operate normally, apply an input voltage of 24 Vac. If the Marquee/Power LED is <b>OFF</b> continuously, the controller does not have sufficient power or has failed.  |
| Diagnostic present         | Several diagnostics affect DX and electric heat operation. For detailed information about these diagnostics, refer to <a href="#">Table 38, p. 104</a> .   |
| Normal operation           | The controller controls compressor or electric heat outputs as needed to meet the unit capacity requirements.  |
| Unit configuration         | The controller must be properly configured based on the actual installed end devices and application. If the unit configuration does not match the actual end device, DX or electric heat may not operate correctly.   |
| Requested mode off         | The user can communicate a desired operating mode (such as <b>OFF</b> , heat, and cool) to the controller. If <b>OFF</b> is communicated to the controller, the unit shuts off the compressor or electric heat.  |
| Freeze avoidance           | When the fan is <b>OFF</b> with no demand for capacity (0%), and the outdoor air temperature is below the freeze avoidance setpoint, the controller disables compressors and electric heat outputs (100%) to prevent coil freezing. This includes unoccupied mode when there is no call for capacity or any other time the fan is <b>OFF</b> . |

## Outdoor Air Dampers with Symbio™ 400-B Controller

**Table 43. Outdoor air damper remains closed**

| Probable Cause                 | Explanation   |
|--------------------------------|---|
| Unit wiring                    | The wiring between the controller outputs and the outdoor air damper must be present and correct for normal outdoor air damper operation. Refer to applicable wiring diagram.   |
| Failed end device              | Check damper actuator to ensure proper operation.   |
| No power to the controller     | If the controller does not have power, the outdoor air damper does not operate. For the controller to operate normally, apply an input voltage of 24 Vac. If the Marquee/Power LED is <b>OFF</b> continuously, the controller does not have sufficient power or has failed. |
| Diagnostic present             | Several diagnostics affect outdoor air damper operation. For detailed information about these diagnostics, refer to <a href="#">Table 38, p. 104</a> .  |
| Normal operation               | The controller opens and closes the outdoor air damper based on the controller's occupancy mode and fan status. Normally, the outdoor air damper is open during occupied mode when the fan is running and closed during unoccupied mode.                                    |
| Unit configuration             | The controller must be properly configured based on the actual installed end devices and application. If the unit configuration does not match the actual end device, the outdoor air damper may not work correctly.  |
| Warm-up and cool-down sequence | The controller includes both a morning warm-up and cool-down sequence to keep the outdoor air damper closed during the transition from unoccupied to occupied. This is an attempt to bring the space under control as quickly as possible.                                  |
| Requested mode off             | The user can communicate a desired operating mode (such as <b>OFF</b> , heat, or cool) to the controller. If <b>OFF</b> is communicated to the controller, the unit closes the outdoor air damper.  |

**Table 44. Outdoor air damper remains open**

| Probable Cause     | Explanation  |
|--------------------|--|
| Unit wiring        | The wiring between the controller outputs and the outdoor air damper must be present and correct for normal outdoor air damper operation. Refer to applicable wiring diagram.  |
| Failed end device  | Check damper actuator to ensure proper operation.  |
| Normal operation   | The controller opens and closes the outdoor air damper based on the controller occupancy mode and fan status. Normally, the outdoor air damper is open during occupied mode when the fan is running and closed during unoccupied mode (see " <a href="#">Modulating Outdoor/Return Air Damper</a> ," p. 83). |
| Unit configuration | The controller must be properly configured based on the actual installed end devices and application. If the unit configuration does not match the actual end device, the outdoor air damper may not work correctly.   |

## ECM Motors

### ⚠ WARNING

#### Hazardous Voltage w/Capacitors!

Failure to disconnect power and discharge capacitors before servicing could result in death or serious injury.

Disconnect all electric power, including remote disconnects and discharge all motor start/run capacitors before servicing. Follow proper lockout/tagout procedures to ensure the power cannot be inadvertently energized. Verify with a CAT III or IV voltmeter rated per NFPA 70E that all capacitors have discharged.

An electronically commutated motors (ECM) is a closed loop system that has equipment protections and envelope enforcements. Do not assume that the motor has failed without first consulting the VelociTach™ engine status/diagnostics screen. In many cases, the engine shuts down the motor operation and locks it out to prevent equipment damage.

Electric heat operation and changeover coil control on CSTI units are coordinated by the VelociTach motor control board.

The mini-access lid on the front of the main control panel lid has the VelociTach troubleshooting/setup guide affixed to the back of the lid. This guide is unit-specific and should be consulted before determining the disposition of a unit.

The adapter boards contain high voltage. Configuration adjustments to the VelociTach board should be made through the SMALLER of the two low-voltage lids on the front of the control panel, through the low-voltage insulation/shielding.

### ⚠ WARNING

#### Hazardous Voltage!

Failure to disconnect power before servicing could result in death or serious injury.

Disconnect all electric power, including remote disconnects before servicing. Follow proper lockout/tagout procedures to ensure the power can not be inadvertently energized. Verify that no power is present with a voltmeter.

## General Information

The VelociTach™ motor control board oversees and monitors all motor operations and changes to speed resulting from:

- Direct fan speed requests
  - Customer fan speed switches
  - Thermostat fan speed, On or 0–10V requests
  - Automatic fan request from Tracer® controllers
- Indirect fan speed requests

- Electric heat requests will bring the fan to the proper speed.
- Conflicting fan speed requests
  - If two or more commands are received (direct or indirect), the fan will honor the higher speed requested.

**Note:** In some cases, indirect requests will result in fan behavior change regardless of whether the end-device fails to actuate (due to device failure, or safety/down-stream lockouts).

The VelociTach™ motor control board also coordinates the operation of electric heat, electric/hydrionic heat lockouts, and CSTI changeover coil operation.

## Troubleshooting Tips

- VelociTach motor control board configuration must perfectly match the factory-supplied ECM.
  - Refer to “Adjustments,” p. 70 for configuration of the motor control board.
- The VelociTach™ motor control board will display troubleshooting information, and contains dual tachometers to aid in performance verification.
- Under normal circumstances, the VelociTach display will display the operational status of the motors and electric heat circuit/sensors, however, a malfunction will drive a priority display mode that will present the error code instantly to the screen. The error must be cleared by solving by powering down, removing the cause of the problem and restarting the engine board.
- VelociTach label setup document (affixed to the back of the low voltage access lid) should be used to verify engine configuration settings.
- For proper operation of the system, all plugs must be firmly seated in all boards and motors. Insecure connections will cause malfunction and the system will shutdown.
- Do not unplug or plug-in motors or connectors while the system is receiving a speed request of any kind. The system must be powered down before plugging or unplugging connections to the adapter boards, engine boards or motors. Failure do so will register diagnostics or cause unsafe operation and reduction in the contact life of the connectors.
- The motor will not spin if plugged in while the ECM engine is requesting power.

## Motor

The motor connections and motor plug connections to the adapter boards should be secure. Unit should be powered off to check the fit of the connectors.

When configured correctly, the system will always respond positively to direct, indirect, and conflicting speed requests with very few exceptions.

**Table 45. Motor does not spin, spins too slowly**

| Situation  | Probable Cause  | Solution  |
|--|---|---|
| Motor has been locked out due to engine locked rotor protection  | Motor 1 has an obstruction. "Status Display" will be interrupted to display:<br>L0CH @ rLr I @ LrPl             | <ul style="list-style-type: none"> <li>Remove obstruction from the fan wheel.</li> <li>Ensure that motor plugs and all plugs to adapter boards and the ECM engine board are secure</li> <li>Verify that the configuration does not specify a motor that is physically missing. Most units require only one motor. The controller is made aware of the missing motor by specifying all speeds related to Motor 2 to 0 rpm.</li> <li>Verify that rLr and rLr, the low motor signal output limits, are set correctly.</li> </ul> |
| Motor has been locked out due to overspeed or runaway condition  | Motor 1 has an overspeed condition. The "Status Display" will be interrupted to display:<br>05Pd → rLr I → 05Pd | <ul style="list-style-type: none"> <li>Ensure that set-screw is attached firmly to the motor shaft.</li> <li>Ensure that motor plugs and all plugs to adapter boards and the ECM engine board are secure.</li> <li>Verify that the configuration does not specify a speed lower than 450 rpm for the affected motor.</li> </ul>   |
| VSP Inputs (0–10V inputs) are of the wrong polarity  | Variable speed (VSP) inputs may not be properly wired to 1TB4   | <ul style="list-style-type: none"> <li>Do not short the courtesy 10 Vdc supply to chassis or loads that require greater than 10 mA of DC current.</li> <li>Observe proper polarity of 0–10 Vdc inputs. Failure to observe proper polarity can cause failure of the VelociTach™ motor control board, the customer-supplied controller, or the Tracer@ZN controller.</li> </ul>   |
| Customer Controller output signal to VSP Inputs are too low.<br><b>Note:</b> If the customer supplied controller outputs signals that are below the noise threshold, they will be ignored by the ECM Engine. | Noise floor is set too high.  | <ul style="list-style-type: none"> <li>The VelociTach™ motor control board contains an adjustable noise floor parameter, uFLr that can be configured to reject signals below the noise floor.</li> <li>The noise floor parameter is set too high, it can be lowered as long as there are acceptable noise levels on the inputs lines.</li> </ul>  |

Typical equipment and controls design practice will ensure that the fans will come on if there is a call for heat, cool, or ventilation. In most cases, we will depend on the controller/thermostat to call for the fan to come on when appropriate, but during calls for electric heat, or calls for heat on CSTI units equipped with electric heat, as a call for the appropriate fan speed. This behavior, as described previously, is an indirect request.

When a call for electric heat is made, the system will positively drive the fan on to the correct speed, regardless of whether the controller has asked for fan operation or not. The unit design incorporates an interlock instead of a lock-

out. (It does not lock out electric heat if the fan is set to off; it brings the fan on.)

**Note:** *In many cases, indirect requests will result in fan behavior change regardless of whether the end-device fails to actuate (due to device failure, or safety/down-stream lockouts). If there is hot water available on CSTI units with changeover coils and electric heat, we will still drive the fan to the appropriate electric heat speed.*

If the preceding conditions do not describe the behavior of the unit, the following checks should be performed:

**Table 46. Motor spins too fast or spins without any apparent speed request**

| Situation                 | Probable Cause   |
|---------------------------|--|
| Motor not controllable    | Verify that the voltage jumper on the motor plug harness is absent for 208-230V units and 277V units. If the jumper is present for these units, the motor electronics will be damaged, and the motor will not be controllable. |
| Fan speed request too low | Verify that the fan speed request is not below 450 rpm.  |

**Table 46. Motor spins too fast or spins without any apparent speed request (continued)**

| Situation                         | Probable Cause  |
|-----------------------------------|---|
| Inputs not of consistent polarity | <p>Verify that the all binary inputs to the customer terminal blocks are of proper and consistent polarity.</p> <ul style="list-style-type: none"> <li>For CSTI units, the fan inputs and end device inputs on TB3 must receive signals that are 24 Vac with respect to the unit chassis.</li> <li>For Fan Speed Switch (FSS) units, that incorporate the Tracer® ZN/CSTI adapter board, all inputs to TB3 must be 24 Vac with respect to unit chassis.</li> <li>For Tracer® ZN units, where there is a desire to use parallel fan inputs on the adapter board TB3 strip, the inputs must be COM (i.e., the inputs will honor only 0 V with respect to unit chassis).</li> </ul> <p>Do not short 24 Vac (pos 1 or pos 2) to chassis; refer to the unit schematic.</p> |
| Failure of motor control board    | <p>Verify that variable speed (VSP) inputs are properly wired to 1TB4.</p> <ul style="list-style-type: none"> <li>Do not short the courtesy 10 Vdc supply to chassis or loads that require greater than 10 mA of DC current.</li> <li>Please observe proper polarity of 0–10 Vdc inputs. Failure to observe proper polarity can cause failure of the VelociTach™ motor control board, the customer-supplied controller or the Tracer® ZN controller.</li> </ul>   |
| Output signals being ignored      | <p>Verify that the signal on the VSP inputs is noise free. The VelociTach™ motor control board contains an adjustable noise floor parameter, <math>\mu F_{Lr}</math>, that can be configured to reject signals below the noise floor.</p> <ul style="list-style-type: none"> <li>If the customer supplied controller outputs signals that are below the noise threshold, they will be ignored by the ECM engine.</li> </ul>   |
| Motor spinning too fast           | <p>Verify that VSP input settings are correct. The motor control board board contains an adjustable digital amplifier, <math>\mu 5c</math>, to compensate for long 10 Vdc cable runs. For normalized (0–10 Vdc) signals, this setting should be set to 1.000. If it is set too high, the motors will run faster than the requested ratio, and will hit the limit <math>\mu h\bar{t}</math> before the input voltage has reached its upper limit.</p>  |
| Motor not controllable            | <p>Verify that <math>\bar{t}L\bar{o}</math> and <math>\bar{t}2L\bar{o}</math>, the low motor signal output limits, are set correctly.</p>   |

## Replacing ECM Components

### **⚠ WARNING**

#### **Hazardous Voltage w/Capacitors!**

**Failure to disconnect power and discharge capacitors before servicing could result in death or serious injury.**

**Disconnect all electric power, including remote disconnects and discharge all motor start/run capacitors before servicing. Follow proper lockout/tagout procedures to ensure the power cannot be inadvertently energized. Verify with a CAT III or IV voltmeter rated per NFPA 70E that all capacitors have discharged.**

## Replacement Guidelines

- ECM motors contain capacitors which store residual energy. Please keep clear of the fan wheels for five minutes after the power has been removed from the system, as a power request with the motor powered off, could result in a very short period of actuation. Unplugging the motor is adequate to ensure that there will be no power request.
- Configuration adjustments to the VelociTach motor in accordance with the parameters that are printed on the label adjacent to the VelociTach board. These parameters reflect the factory settings for the unit. Subsequent changes to parameters made during commissioning will not be reflected in the printed parameters.

- Initial hookups to the CSTI and standard adapter board, including low voltage interconnections, must be made with the power off.
- Do not make connections to the motors or the adapter boards while power is ON. Do not remove connections to the motor or the adapter boards while the power is ON.
- Caution should be taken to stay clear of hazardous voltages, moving parts and electric heat elements while making adjustments to the VelociTach™ motor control board. If it is not practical to stay clear of these areas during adjustment, please contact Trane Global Parts for configuration kit that allows easy powering of the engine board outside of the unit with a 9V battery.
- For safe operation, it is necessary to configure replacement boards to match the setup/switch configuration of the previously installed boards.
- Ensure that new circuit modules are firmly seated on the nylon standoffs, and that the nylon standoffs are firmly seated on the metal panel
- Ensure that drip-loops are maintained on wiring on pipe end of unit to avoid wicking of water into the unit.
- Before assuming that any of the boards or components in the new system have failed, please ensure that the VelociTach™ motor control board has been configured correctly and that the switches on the CSTI board (where applicable) are set correctly.
- It is necessary to configure the service replacement VelociTach™ motor control board before commissioning the unit. The board is pre-configured with safe values, but will NOT work correctly unless

properly configured. The factory shipped parameter settings are on the label adjacent to the VelociTach™.

- Only genuine Trane replacement components with identical Trane part numbers should be used.
- Unit fan assemblies contain concealed wires that should be removed before the fan-board is removed, to avoid nicking the wire.
- Care should be maintained to retain the order of the motors with respect to the motor plugs. On a unit with two motors, the double-shafted motor will always be to the left side, and will be designated as Motor 2 by the controller.

### Replacement Checklist

#### NOTICE

#### Equipment Damage!

Failure to follow these instructions could result in equipment damage.

**The motor harness attached to the single plug to which the motor mates contains the 115V motor voltage jumper. The motor harness should always be present for 115V units and should not be modified or substituted.**

- Ensure that motor nameplate voltage is the same as unit voltage (for 3-phase/ 4-wire units with Neutral, motor voltage will be L-N, not L1-L2).
- Ensure that motor harness is correct (harness will have jumper installed for 115V units only).
- Ensure that configuration on the VelociTach™ motor control board matches the affixed label.
- Maintain correct plug/motor association. The plugs will have the motor number and shaft configuration printed on an affixed label.
- Ensure that configuration of switches on CSTI adapter board matches depiction of switches on the unit schematic.
- Ensure that all wires are plugged in securely.
- Ensure that edge protection on sharp edges, grommets, and wire management devices are maintained when replacing components.
- Ensure that blunt-tip screws are used when in the proximity of wire harnesses.

### Circuit Module Replacement

1. Circuit modules are equipped with nylon standoffs which can either be removed by squeezing the barbs at the rear of the control panel, or squeezing the latch above the circuit module. If the latter method is chosen, the standoffs will be retained on the metal panel. The new standoffs (affixed to the replacement modules) can be removed if necessary, so the new module circuit board can be attached to the retained standoffs.

Figure 81. Remove PCB

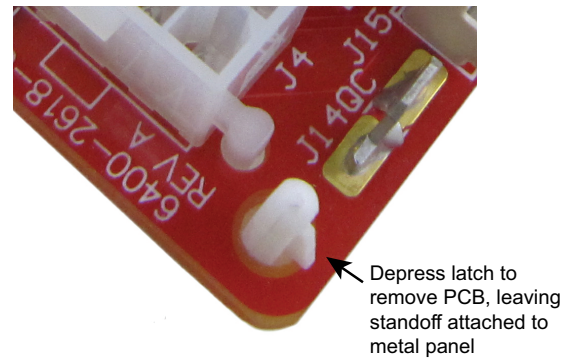

2. If replacing the VelociTach™ motor control board, special care should be taken to avoid electro-static discharge damage. Please use an ESD protection wrist-strap and frequently touch a grounded surface (with unit power off) to discharge any static buildup.
3. Replace connectors carefully onto the appropriate board. For units with a green wire attached to the CSTI or standard adapter boards, please ensure that the green wire is attached to the engine board white connector as shown in Figure 82, p. 111.

Figure 82. CSTI wiring

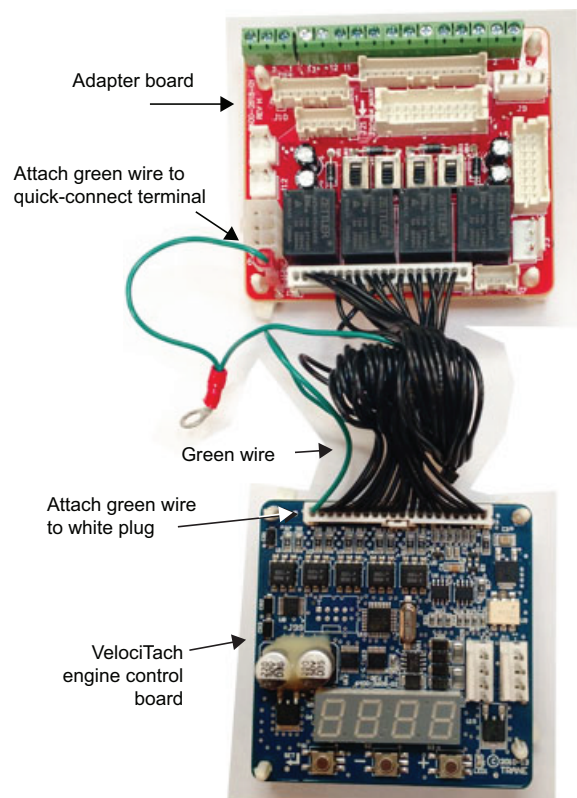

4. Ensure that the new VelociTach™ motor board controller is configured to match the configuration label that is present on the unit. It is necessary to configure the VelociTach™ board to avoid improper operation of

the unit, discomfort to the end user, and loud fan operation.

**Figure 83. Configure VelociTach™ board**



5. Ensure that the CSTI adapter board switches are set correctly, as indicated in the unit schematic (where applicable) shown in [Figure 84, p. 112](#).

**Figure 84. Ensure CSTI adapter board switches are set correctly**

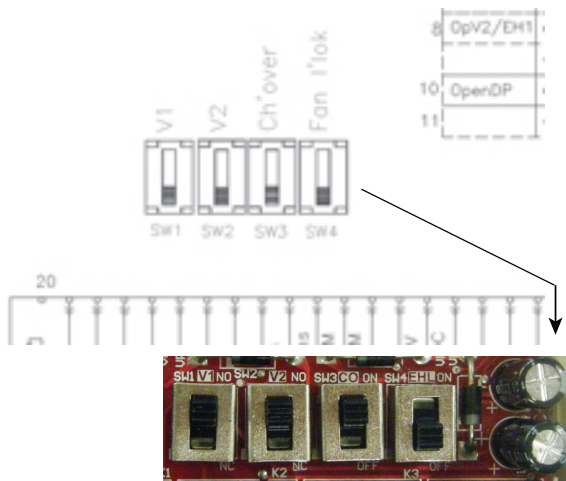

6. After replacing modules, commission the unit by performing at a minimum, refer to "Fan Speed Response Verification," p. 76.

## Application Notes

The ECM motor has some notable differences to traditional designs.

### RPM Mode

The motors are programmed from the factory to run in rpm mode and will not change rpm based on external static pressure, except at the performance limits of the motor/controller. The units are shipped with the rpm set to the selected value for High. The speeds can be changed for high, medium, and low operation, but should not be changed for the electric heat actuation speeds.

Generally, the fans deliver less cfm for the same rpm, if the static is increased and the power will decrease. The fan will deliver more cfm for the same rpm, if the static is decreased and the fan power will increase. A unit with high static configuration should not be used to free-deliver air (i.e., with no ducting attached).

## Field Power Wiring

This motor uses an electronic variable speed motor control, which includes a line reactor to minimize power line harmonic currents. It is recommended that good wiring practices be followed to manage building electrical power system harmonic voltages and currents to avoid electrical system problems or other equipment interaction.

## Performance Boundaries

While the speeds of the fan motors can be adjusted, never program a fan speed outside the operating limits for the given unit size. In many cases, units configured for high-static operation will not achieve the desired rpm if the ESP of the unit is too low, or the unit is allowed to free-discharge. The VelociTach™ motor control board contains settings that will limit the output power of the motor under these overload conditions. If the motors cannot achieve rpm close to the target for a specific period of time, the unit will disable electric heat and fan-status indicators.

## MCA/MOP and Power Draw

ECM motors have variable output but are shipped at specific settings to deliver proper performance and reliability. The power draw indicated in the catalog indicates the power consumed when applied properly (as shipped and with the nominal ESP applied). However, the nameplate of the unit indicates the maximum input draw of the motor, as the motor settings can be changed to draw more power.

## Electric Heat Relays

For quiet operation, the new BLDC units employ power relays instead of definite purpose contactors for electric heat actuation. The coils of multiple relays are hooked in parallel to simulate a multi-pole contactor as shown in [Figure 85, p. 112](#). Two sets of three relays are used to perform the function of a two 3pole contactors.

**Figure 85. Sample arrangement: electric heat relay**

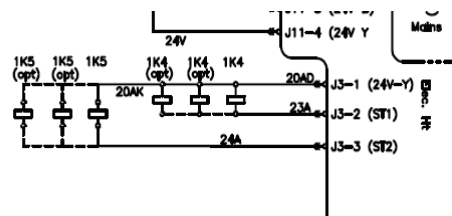

## Troubleshooting Other Unit Functions

In some cases, the normal or abnormal operation of the ECM may interact with other components in the system. Generally, verification of the engine and adapter boards' wiring and configuration should be checked if there are unexplained abnormalities in other areas of the unit:

- Valve operation
- Electric heat operation
- Changeover sensor operation
- Damper operation

- Condensate overflow switch

A high degree of protection is provided on electric heat units. If electric heat fails to actuate, it may be because of one of the following events:

- Fans are failing to meet target speed. If a second motor is not present, all settings for speeds for Motor 2 should be set to 0000.
- Hot water may be available in the changeover coil.
- The connection to analogue input 1 on the Tracer® ZN controller may be reversed in polarity.
- Target speeds for motors may be set too high:
  - The  $FP_{RU}$  parameter may be set incorrectly.
  - The  $R_{PU}$  parameter may be set incorrectly.



# Wiring Diagrams

**Table 47. Wiring diagram matrix**

| Drawing Number       | Description   |
|----------------------|---|
| <b>Power</b>         |   |
| 2311-4278            | Power Schematic, VUV - CSTI and No Controls without Electric Heat                 |
| 4619-4480            | Power Schematic, VUV - CSTI with Electric Heat                                    |
| 2311-4161            | Power Schematic, VUV - Symbio™ 400-B without Electric Heat                        |
| 4619-4479            | Power Schematic, VUV - Symbio™ 400-B with Electric Heat                           |
| <b>Controls</b>      |   |
| 2311-4301            | Controls Schematic, VUV - CSTI with DX Coils and Electric Heat                    |
| 4619-3723            | Controls Schematic, VUV - Symbio™ 400-B with Standard Coils                       |
| 4619-3724            | Controls Schematic, VUV - Symbio™ 400-B with Isolation Valves and face and Bypass |
| 4619-3725            | Controls Schematic, VUV - Symbio™ 400-B with DX Coils                             |
| 4619-3729            | Controls Schematic, VUV - CSTI with Standard Coils                                |
| 4619-3730            | Controls Schematic, VUV - CSTI with Isolation Valves and face and Bypass          |
| 4619-3731            | Controls Schematic, VUV - CSTI with DX Coils                                      |
| 4619-4962            | Controls Schematic, VUV CSTI DX with A2L Coils with EH                            |
| 4619-4963            | Controls Schematic, VUV, CSTI, DX with A2L Coils No EH                            |
| 4619-4964            | Controls Schematic, VUV, UC400-B, Symbio 400-B, DX with A2L Coil                  |
| <b>Zone Sensors</b>  |   |
| 2311-4166            | Zone Sensors, VUV - Symbio™ 400-B   |
| <b>Electric Heat</b> |   |
| 2311-4172            | Electric Heat Schematic, VUV 1PH 3 Element (Fused)                                |
| 2311-4173            | Electric Heat Schematic, VUV 1PH 3 Element  |
| 2311-4174            | Electric Heat Schematic, VUV 1PH 3 Element  |
| 2311-4175            | Electric Heat Schematic, VUV 1PH 4 Element (Fused)                                |
| 2311-4177            | Electric Heat Schematic, VUV 1PH 4 Element (Fused)                                |
| 2311-4178            | Electric Heat Schematic, VUV 1PH 4 Element  |
| 2311-4179            | Electric Heat Schematic, VUV 1PH 4 Element  |
| 2311-4180            | Electric Heat Schematic, VUV 1PH 6 Element (Fused)                                |
| 2311-4181            | Electric Heat Schematic, VUV 1PH 6 Element (Fused)                                |
| 2311-4182            | Electric Heat Schematic, VUV 3PH 3 Element  |
| 2311-4183            | Electric Heat Schematic, VUV 3PH 3 Element  |
| 2311-4185            | Electric Heat Schematic, VUV 3PH 4 Element (Fused)                                |
| 2311-4186            | Electric Heat Schematic, VUV 3PH 4 Element  |
| 2311-4187            | Electric Heat Schematic, VUV 3PH 4 Element  |
| 2311-4188            | Electric Heat Schematic, VUV 3PH 6 Element (Fused)                                |
| 2311-4189            | Electric Heat Schematic, VUV 3PH 6 Element (Fused)                                |

**Table 47. Wiring diagram matrix (continued)**

| Drawing Number          | Description                                |
|-------------------------|--|
| 2311-4190               | Electric Heat Schematic, VUV 3PH 6 Element |
| <b>Component Layout</b> |  |
| 2311-4560               | Component Layout, VUV                      |

**Note:** Wiring diagrams can be accessed using e-Library by entering the diagram number in the literature order number search field or by contacting technical support.

Trane - by Trane Technologies (NYSE: TT), a global innovator - creates comfortable, energy efficient indoor environments for commercial and residential applications. For more information, please visit [trane.com](https://trane.com) or [tranetechnologies.com](https://tranetechnologies.com).

Trane has a policy of continuous product and product data improvements and reserves the right to change design and specifications without notice. We are committed to using environmentally conscious print practices.

UV-SVX006D-EN 19 Jun 2026  
Supersedes UV-SVX006C-EN (December 2025)

©2026 Trane